



US00D481790S

(12) **United States Design Patent**
Moreno

(10) **Patent No.:** **US D481,790 S**
(45) **Date of Patent:** **** Nov. 4, 2003**

- (54) **COMBINATION FAN BLADE CAGE AND MOTOR HOUSING**
- (75) Inventor: **Eleobardo Moreno**, St. John, IN (US)
- (73) Assignee: **Lakewood Engineering and Manufacturing Co.**, Chicago, IL (US)
- (**) Term: **14 Years**
- (21) Appl. No.: **29/163,282**
- (22) Filed: **Jul. 1, 2002**

Related U.S. Application Data

- (62) Division of application No. 29/146,540, filed on Aug. 10, 2001, now Pat. No. Des. 459,796.
- (51) **LOC (7) Cl.** **23-04**
- (52) **U.S. Cl.** **D23/412**
- (58) **Field of Search** D23/370, 378, D23/381, 382, 411, 412; 416/247 R, 246

(56) **References Cited**

U.S. PATENT DOCUMENTS

2,100,994 A	11/1937	Cohen	
2,154,313 A	4/1939	McMahan	
D142,260 S	8/1945	Lee	
D159,692 S	* 8/1950	Steinhart D23/382
2,554,602 A	5/1951	Sutton	
2,652,974 A	9/1953	Pettel	
2,805,820 A	9/1957	Evarts	
3,173,478 A	3/1965	Maycen	
3,446,429 A	5/1969	Suzuki et al.	
4,120,615 A	10/1978	Keem et al.	
4,486,144 A	12/1984	Hung	
4,838,151 A	6/1989	Shin-Chin	
4,872,399 A	10/1989	Chaney	

(List continued on next page.)

OTHER PUBLICATIONS

U.S. Trademark Reg. No. 1,697,509; Registered Jun. 30, 1993; Owner: Vornado Air Circulation Systems, Inc. for: Electric Fans in Class 11.

Product Catalog entitled "Fans", Lakewood Engineering & Mfg. Co., (20 pages), 11/98.
 Product Catalog entitled "Fans", Lakewood Engineering & Mfg. Co., (20 pages) 1/01.
 Product Literature of Lasko Air Circulators Fans (2 pages).
 Product Catalog entitled, "Portable Air Circulators", Lasko Metal Products, 2/98.
 Product Literature of a Holmes Convertible and Oscillating Fans, 15 pages (two sided).
 Product Literature of Cyclone Fans (8 pages).
 Product Catalog entitled, "Restoration Hardware", Restoration Hardware, Fall, 2000, p. 38.

Primary Examiner—Lisa Lichtenstein
(74) *Attorney, Agent, or Firm*—Wallenstein & Wagner, Ltd.

(57) **CLAIM**

The ornamental design for a combination fan blade cage and motor housing, as shown and described.

DESCRIPTION

FIG. 1 is a perspective view of the combination fan blade cage and motor housing.
 FIG. 2 is a front elevational view of the combination fan blade cage and motor housing.
 FIG. 3 is a side elevational view of the combination fan blade cage and motor housing.
 FIG. 4 is a rear elevational view of the combination fan blade cage and motor housing.
 FIG. 5 is a side elevational view (opposite the side elevational view of FIG. 3) of the combination fan blade cage and motor housing.
 FIG. 6 is a top plan view of the combination fan blade cage and motor housing.
 FIG. 7 is a bottom plan view of the combination fan blade cage and motor housing; and,
 FIG. 8 is a cross-sectional view of the fan blade cage portion of the design taken along line 8—8 in FIG. 1.
 The broken line showing of environmental structure in FIGS. 1—8 is for illustrative purposes only and forms no part of the claimed design.

1 Claim, 8 Drawing Sheets

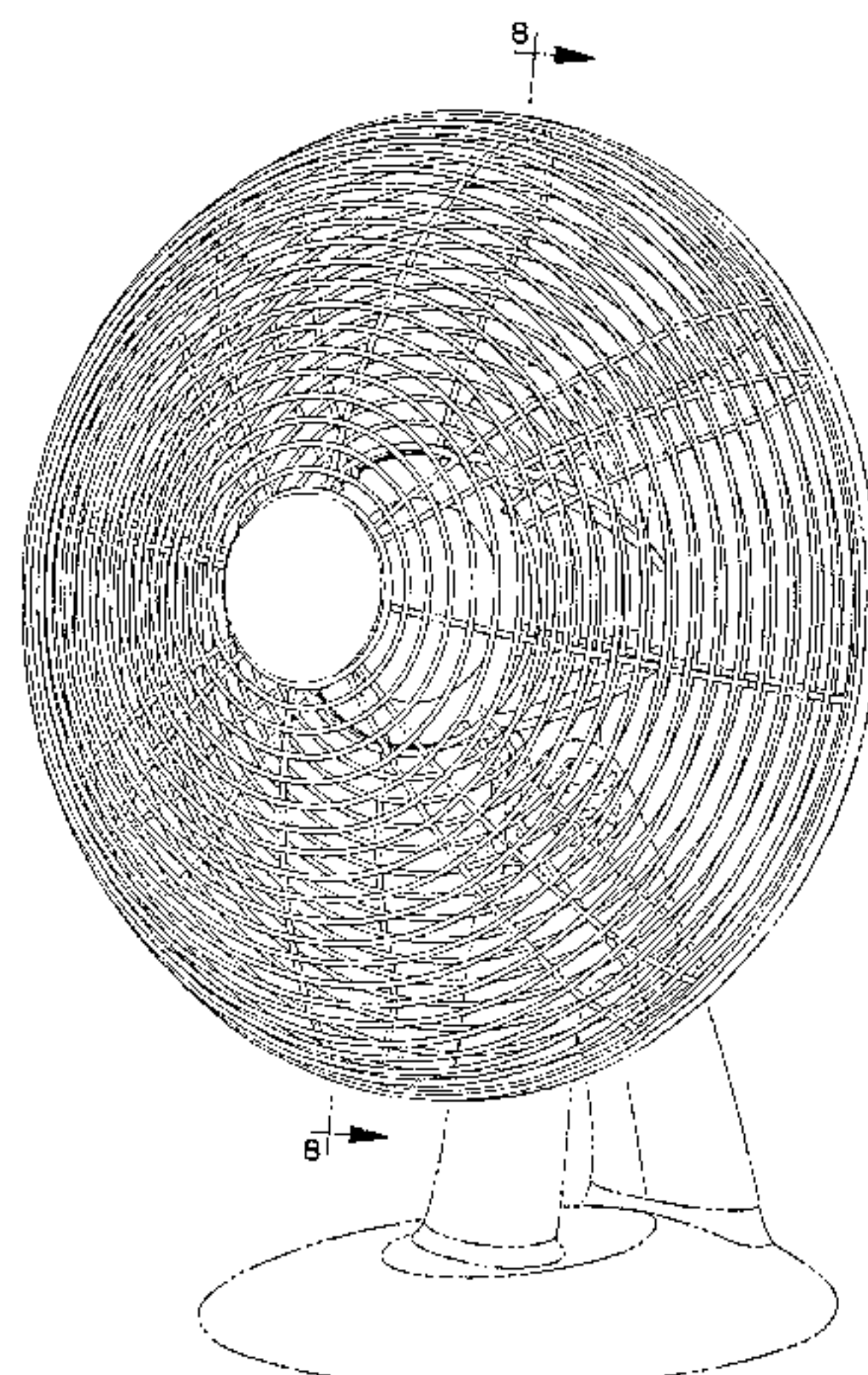

US D481,790 S

Page 2

U.S. PATENT DOCUMENTS

D312,124 S	11/1990	Coup et al.	D392,735 S	3/1998	Gonzales et al.
5,118,252 A	6/1992	Chaney	5,730,651 A	3/1998	Chen et al.
D329,089 S	9/1992	Coup et al.	D395,080 S	6/1998	Jané et al.
D336,512 S	6/1993	Cunning	D396,278 S	7/1998	Gonzales
D337,819 S	7/1993	Cunning	D398,983 S	9/1998	Keller et al.
RE34,551 E	2/1994	Coup et al.	D400,242 S	10/1998	Litvin
D346,019 S	4/1994	Cheslock et al.	5,829,956 A	11/1998	Chen et al.
5,342,175 A	8/1994	Patton	D407,478 S	3/1999	Wilson, Jr.
5,382,136 A	1/1995	Nobuta et al.	D408,907 S	4/1999	Moreno
D359,116 S	6/1995	Marvin et al.	D413,664 S	9/1999	Keller et al.
D369,403 S	4/1996	Reveal et al.	D416,619 S	11/1999	Ediger et al.
D376,005 S	11/1996	Litvin	D416,996 S	11/1999	Mack
5,609,473 A	3/1997	Litvin	D418,218 S	* 12/1999	Hsu D23/412
D387,152 S	12/1997	Jané et al.	6,015,265 A	1/2000	Lasko et al.
D388,869 S	1/1998	Wang	D420,121 S	2/2000	Felix-Flender
D389,235 S	1/1998	Jané et al.	6,183,204 B1	2/2001	Chang
D391,357 S	* 2/1998	Chi D23/382	D451,190 S	11/2001	Chen et al.
D391,631 S	3/1998	Litvin			

* cited by examiner

FIG. 1

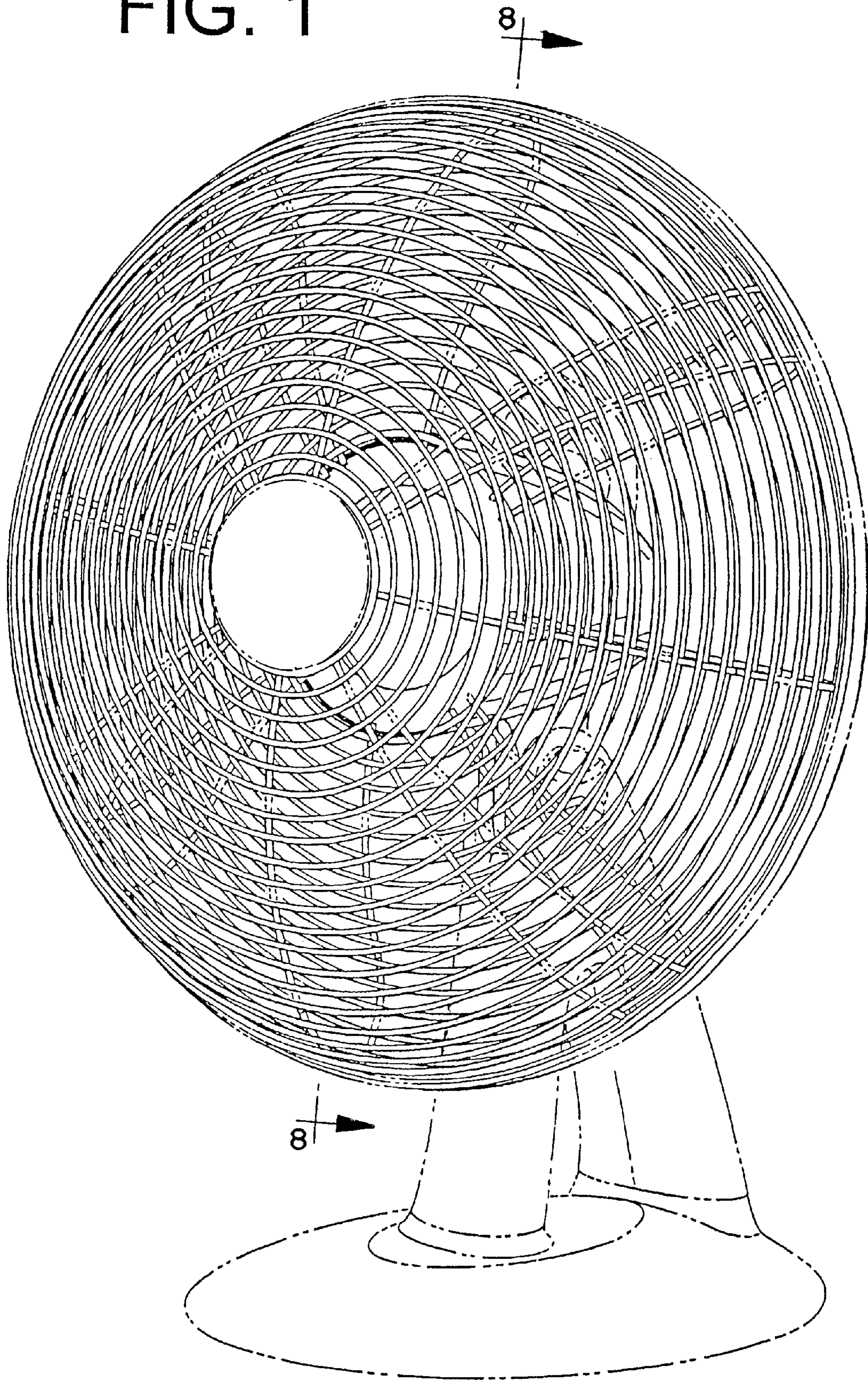

FIG. 2

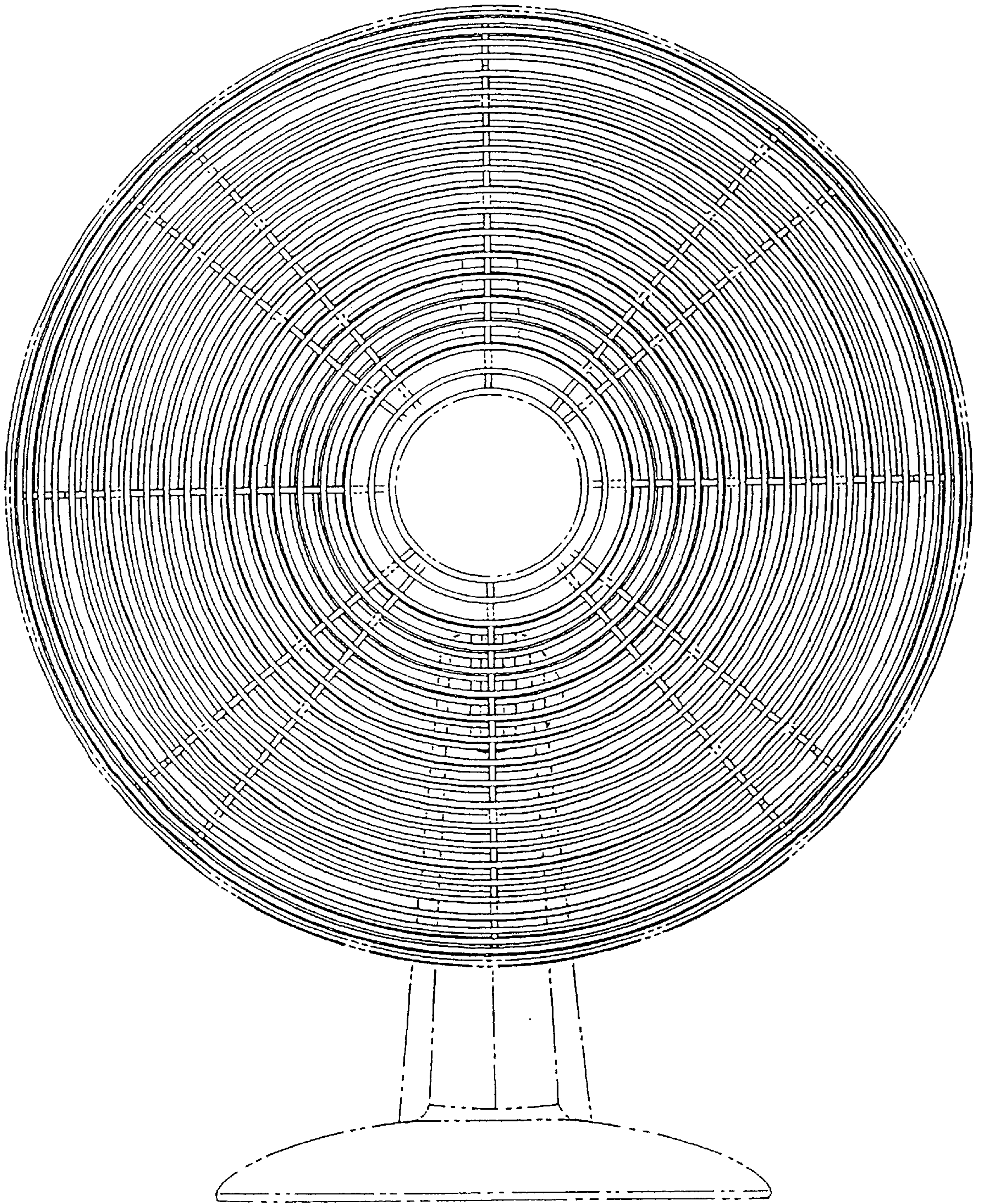

FIG. 3

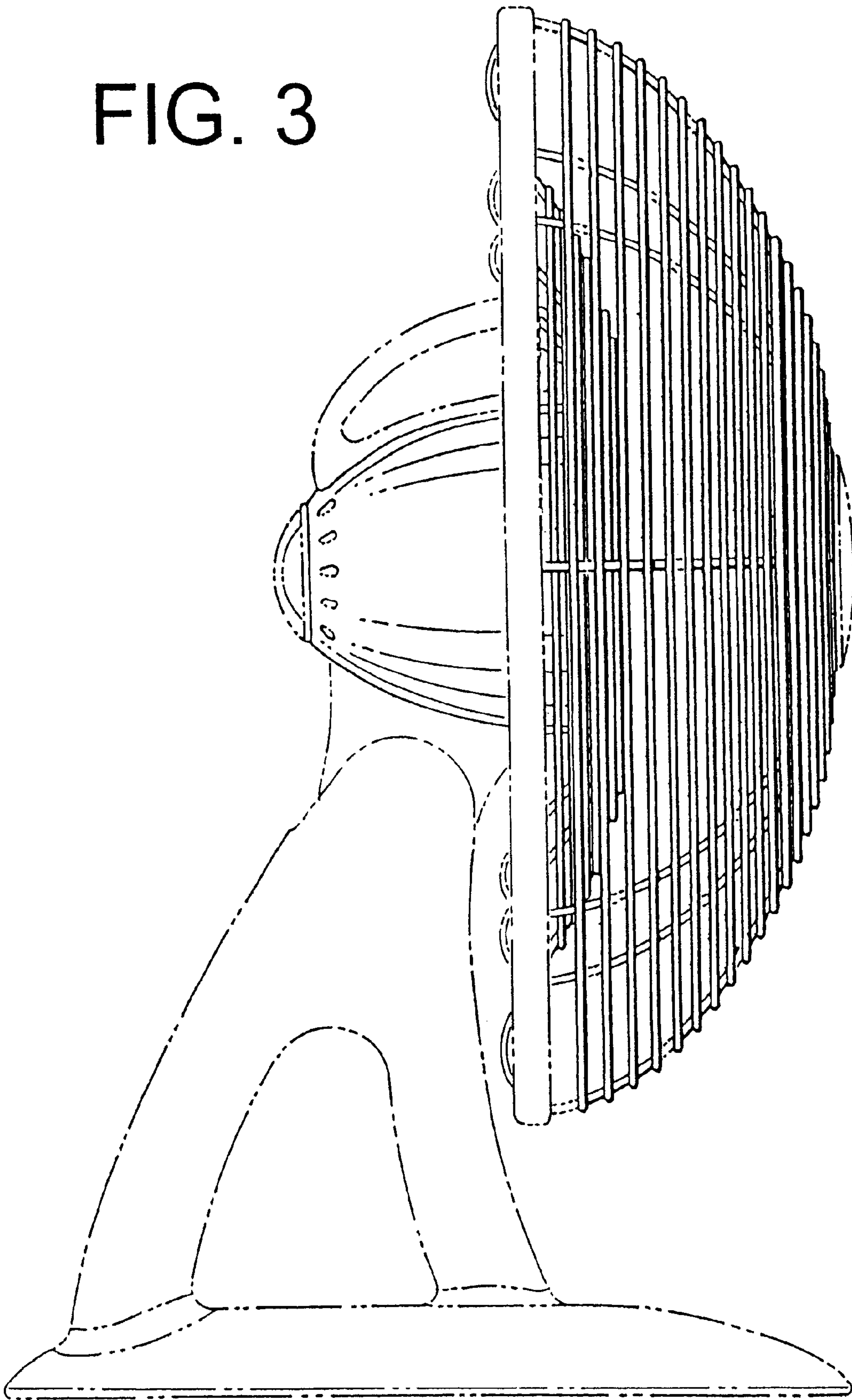

FIG. 4

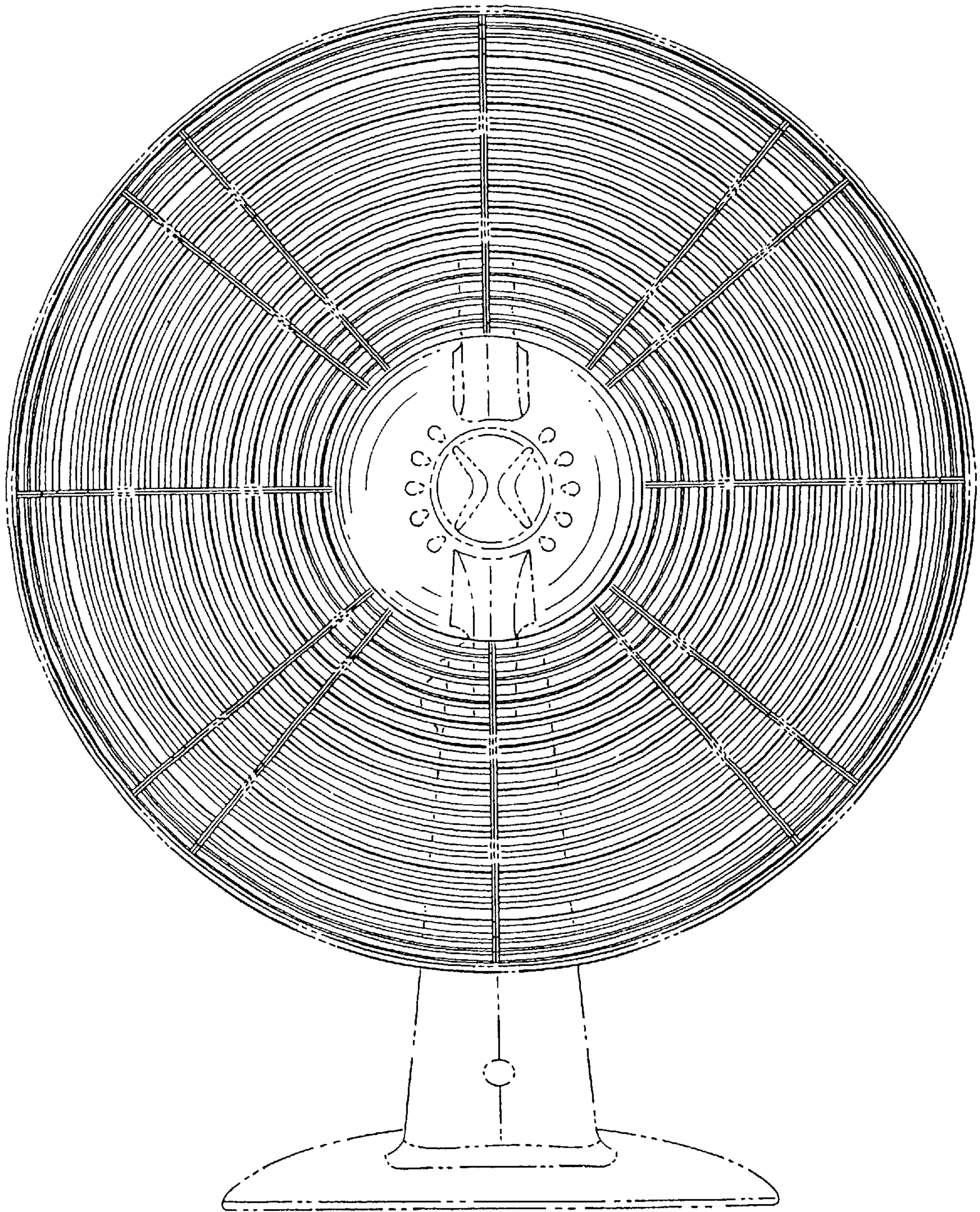

FIG. 5

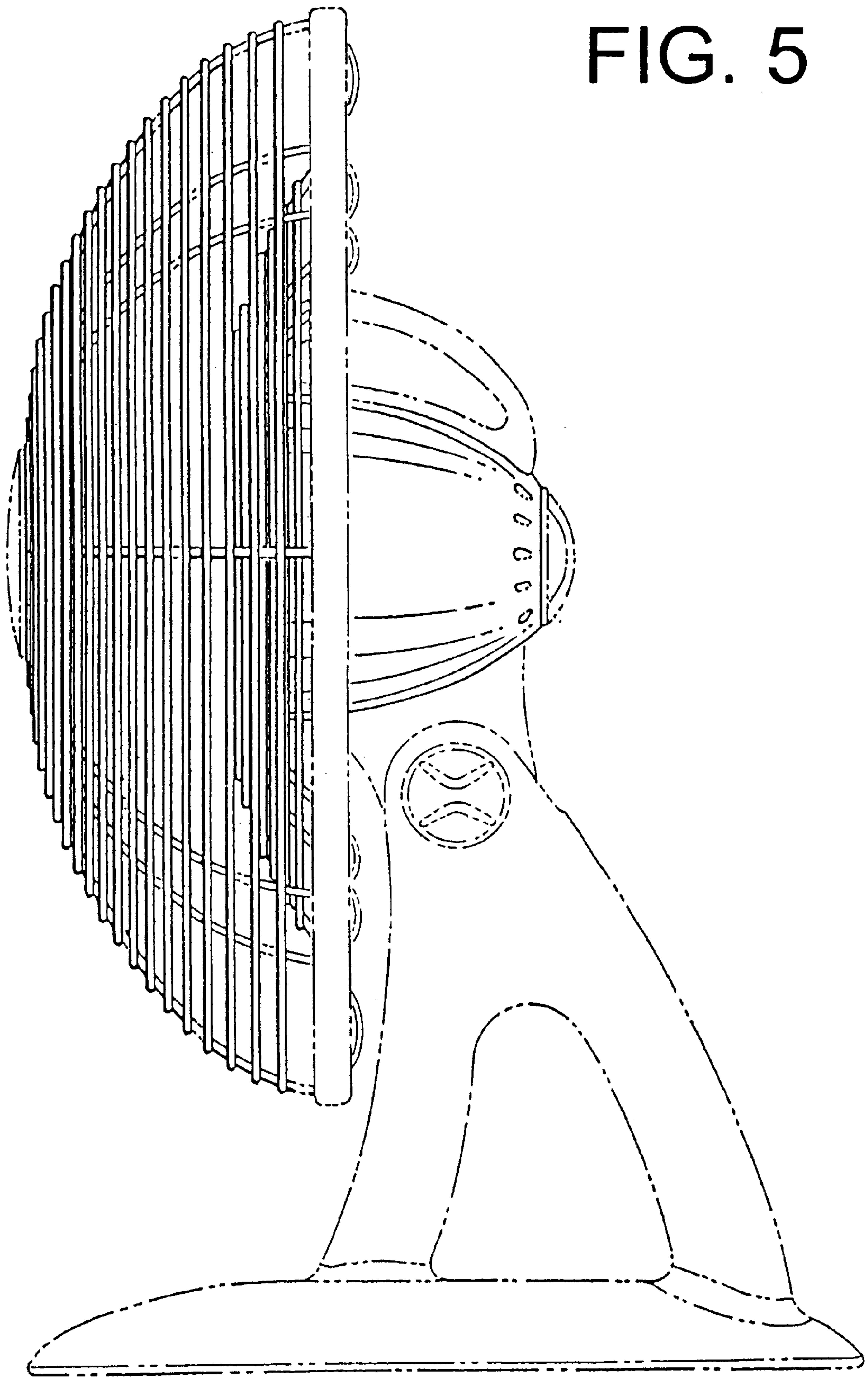

FIG. 6

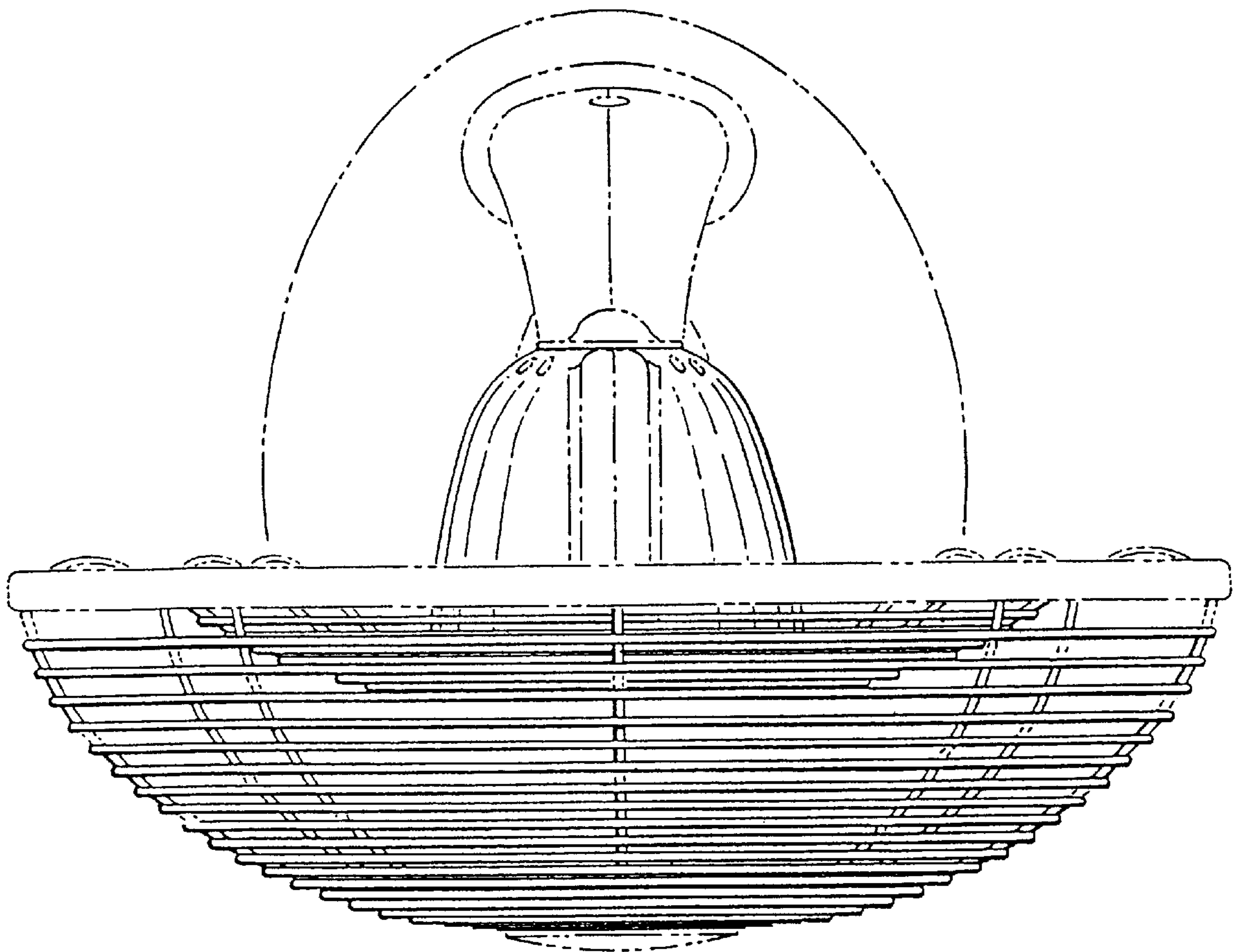

FIG. 7

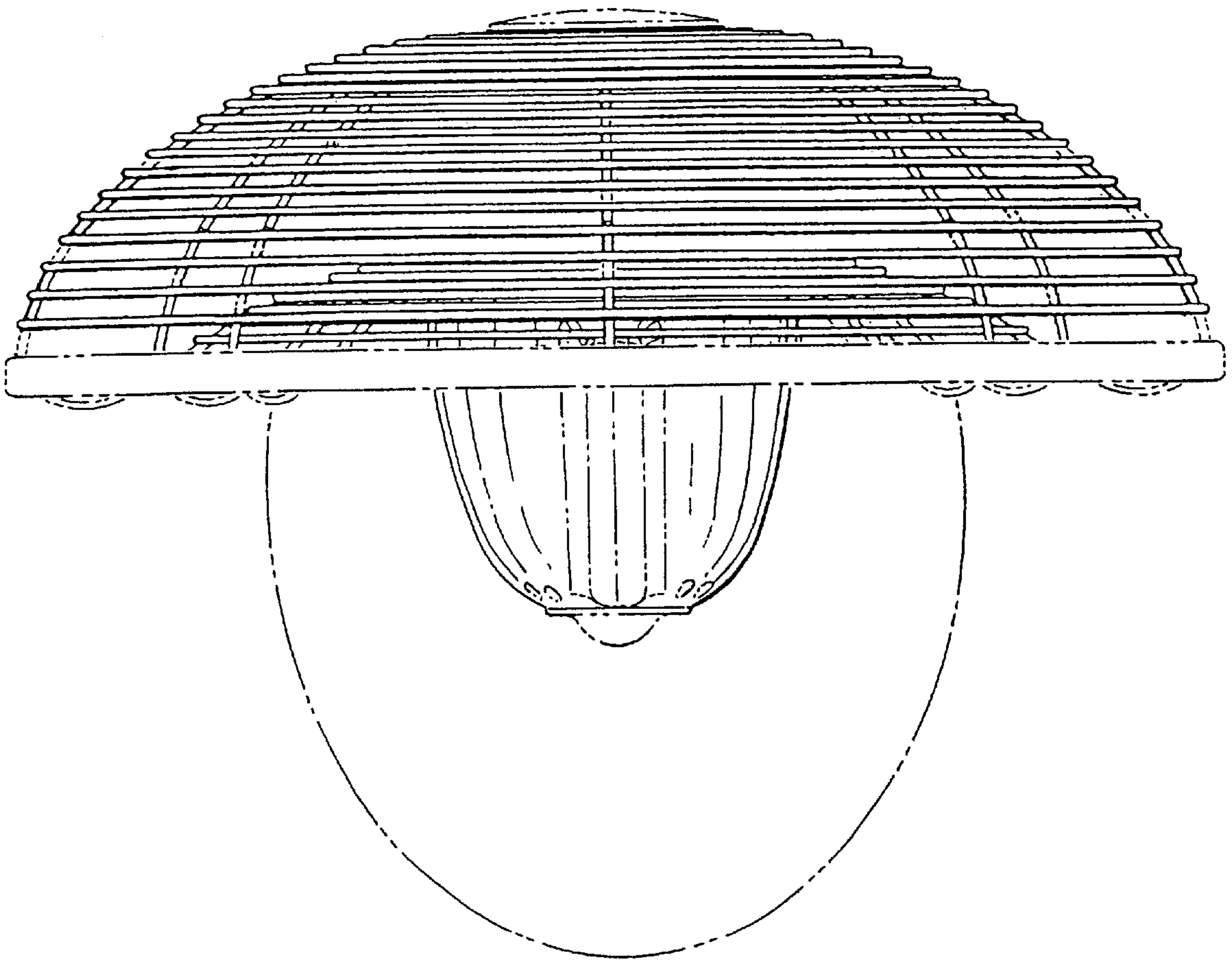

FIG. 8

