



US00D481752S

(12) **United States Design Patent**  
**Pittman**

(10) **Patent No.:** **US D481,752 S**

(45) **Date of Patent:** **\*\* Nov. 4, 2003**

(54) **ADD-ON HEADSTOCK MASS DEVICE FOR A STRINGED INSTRUMENT**

(76) **Inventor:** **Richard Aspen Pittman**, 13994 Simshaw Ave., Sylmar, CA (US) 91342

(\*\*) **Term:** **14 Years**

(21) **Appl. No.:** **29/141,294**

(22) **Filed:** **May 4, 2001**

(51) **LOC (7) Cl.** ..... **17-03**

(52) **U.S. Cl.** ..... **D17/20**

(58) **Field of Search** ..... D17/14-15, 18-21, D17/24, 99; 84/9, 267, 290-291, 293-294, 297 R, 298, 299, 307, 314 R, 354, 453, 318; D8/394, 349, 382, 387, 397; 984/114, 112, 110

(56) **References Cited**

**U.S. PATENT DOCUMENTS**

D140,862 S	*	4/1945	Conlan	.....	D13/161
D210,851 S	*	4/1968	Wallace	.....	D17/20
4,104,947 A	*	8/1978	Oster	.....	84/318
4,712,464 A	*	12/1987	Nance	.....	84/485 R
D355,668 S	*	2/1995	Reagan	.....	D17/21
5,465,643 A	*	11/1995	Beeson	.....	84/297 R
D365,118 S	*	12/1995	Kyser	.....	D17/20
5,708,225 A	*	1/1998	Sherman	.....	84/313
D404,061 S	*	1/1999	Roth	.....	D17/20
5,889,222 A	*	3/1999	Burgess	.....	84/453
6,359,202 B1	*	3/2002	Feiten et al.	.....	84/312 R

**OTHER PUBLICATIONS**

Groove Tubes Catalog Supplement 2000, "Fatfinger" p. A.\*

\* cited by examiner

*Primary Examiner*—Ruth McInroy

(74) *Attorney, Agent, or Firm*—J. E. McTaggart

(57) **CLAIM**

The ornamental design for an add-on headstock mass device for a stringed instrument, as shown and described.

**DESCRIPTION**

FIG. 1 is a top, side perspective view of an add-on headstock mass device for a stringed musical instrument showing my new design;

FIG. 2 is a bottom, side perspective view thereof;

FIG. 3 is a top plan view thereof;

FIG. 4 is a bottom plan view thereof;

FIG. 5 is another bottom plan view thereof;

FIG. 6 is a front elevational view thereof;

FIG. 7 is a side elevational view of both embodiments;

FIG. 8 is a top plan view thereof;

FIG. 9 is a top, side perspective view of a second embodiment thereof;

FIG. 10 is a bottom, side perspective view of FIG. 9;

FIG. 11 is a top plan view of FIG. 9;

FIG. 12 is a bottom plan view of FIG. 9;

FIG. 13 is another bottom plan view of FIG. 9;

FIG. 14 is a front elevational view of FIG. 9; and,

FIG. 15 is a top plan view of FIG. 9.

The two different guitars shown in broken lines in (FIGS. 3-4) and (FIGS. 11-12) represent environmental structure which forms no part of the claimed design.

**1 Claim, 5 Drawing Sheets**

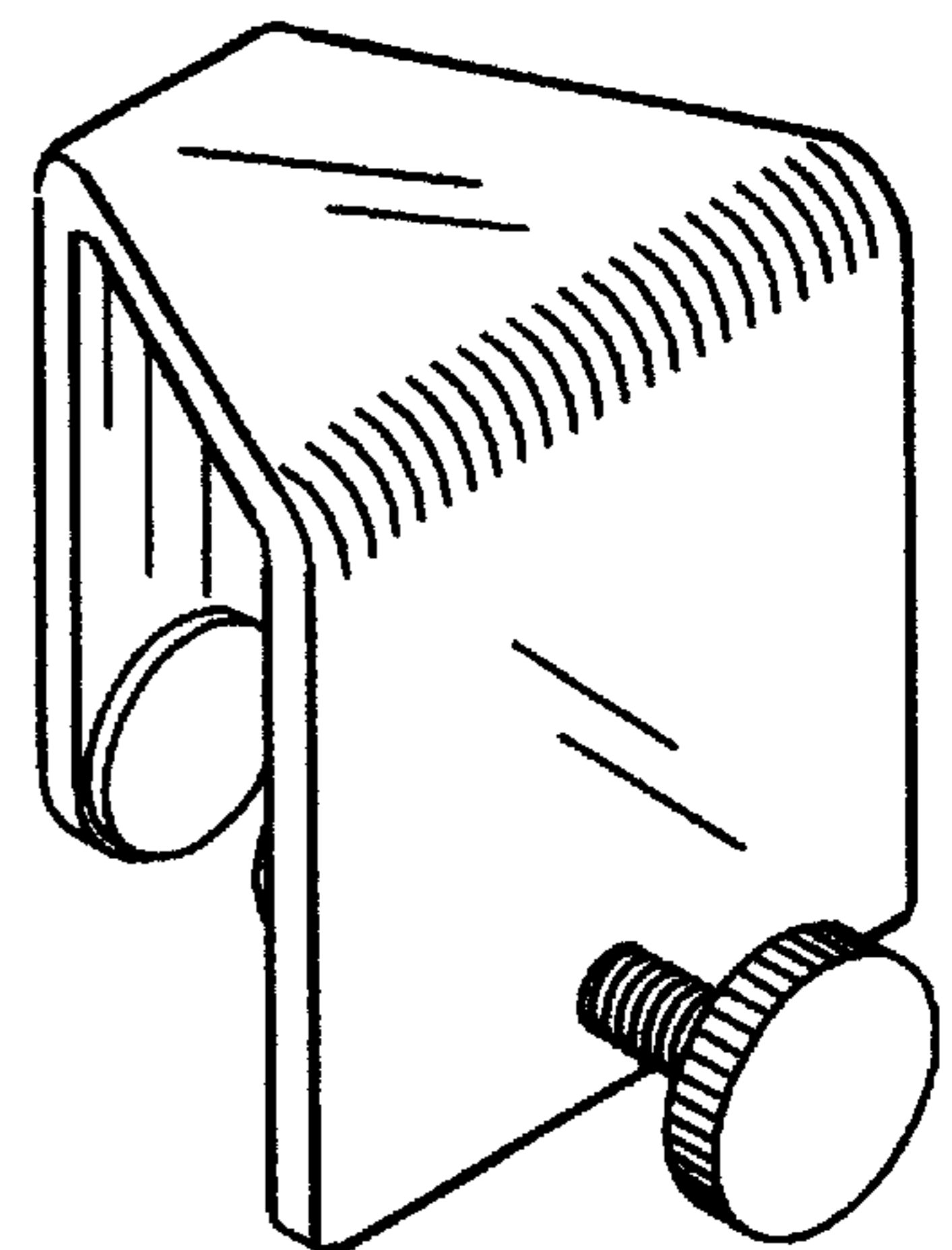
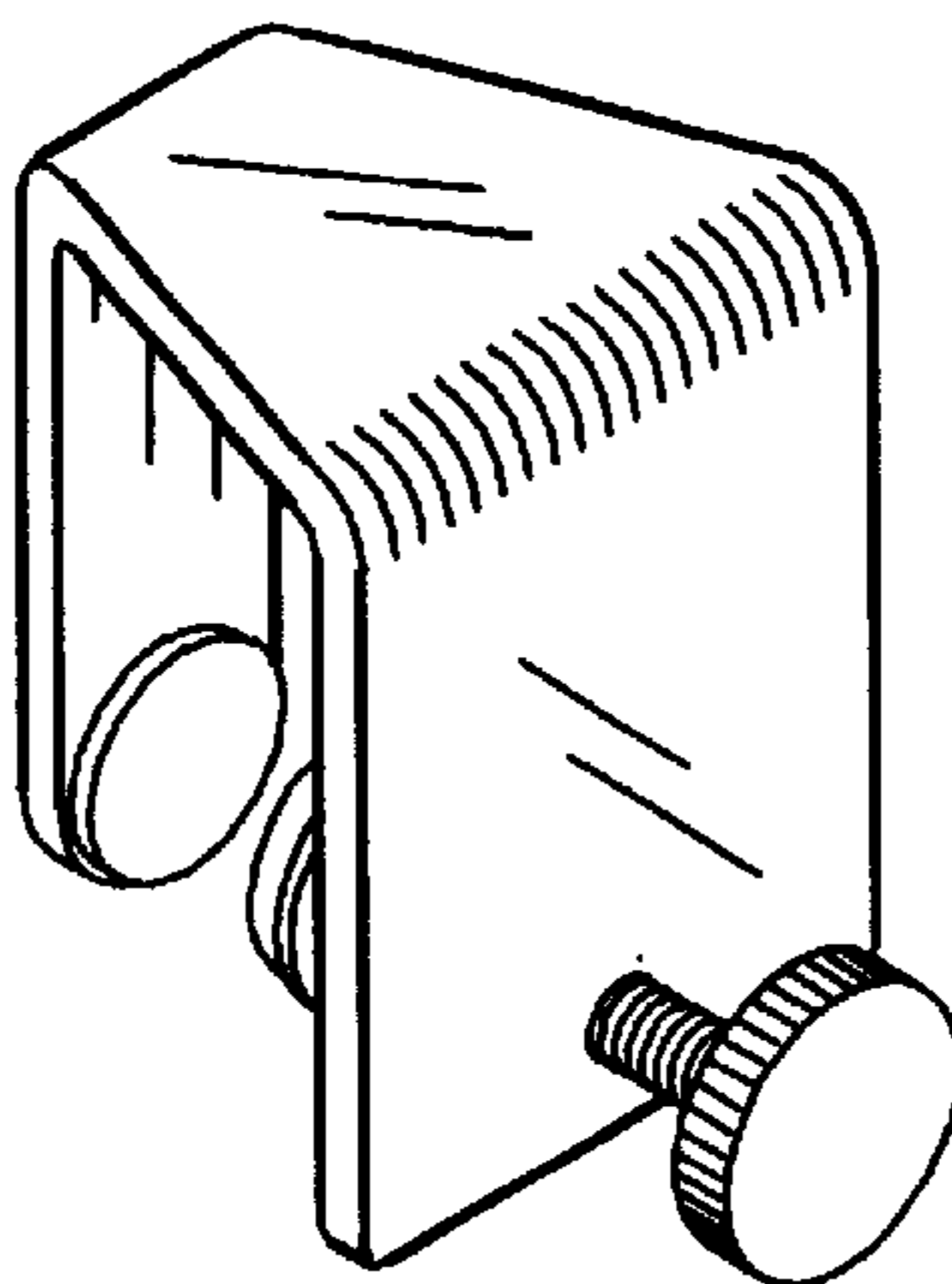
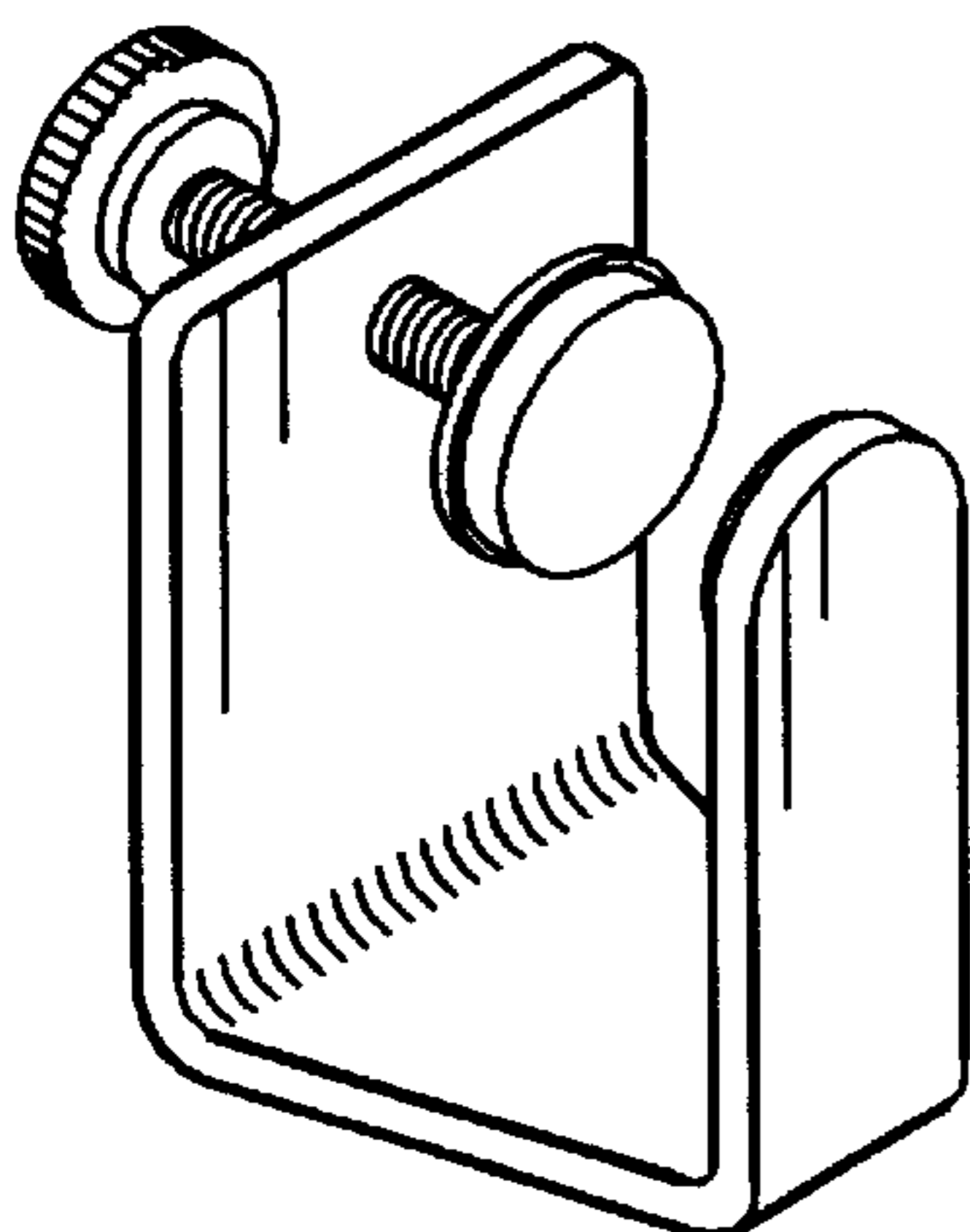

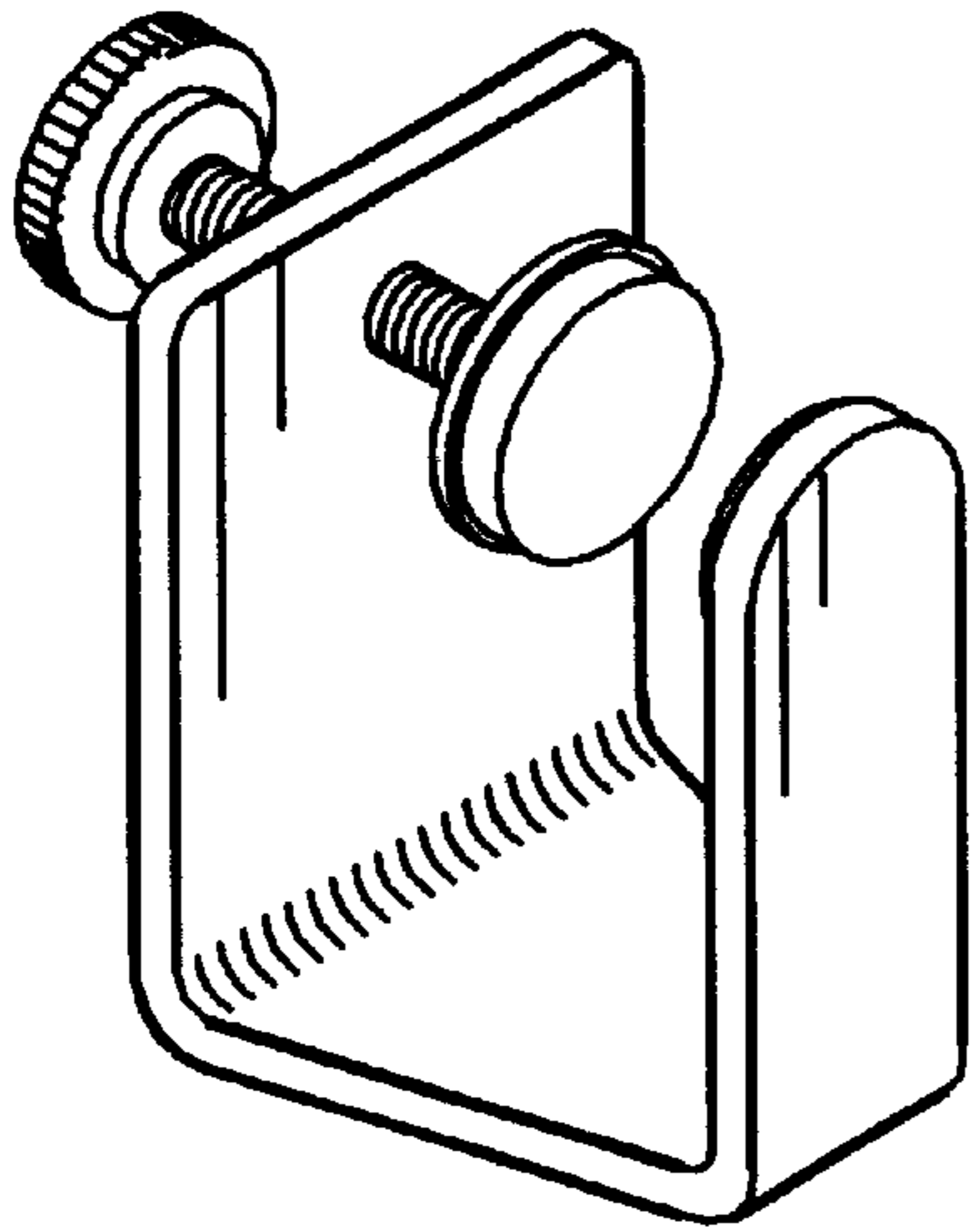

FIG. 1

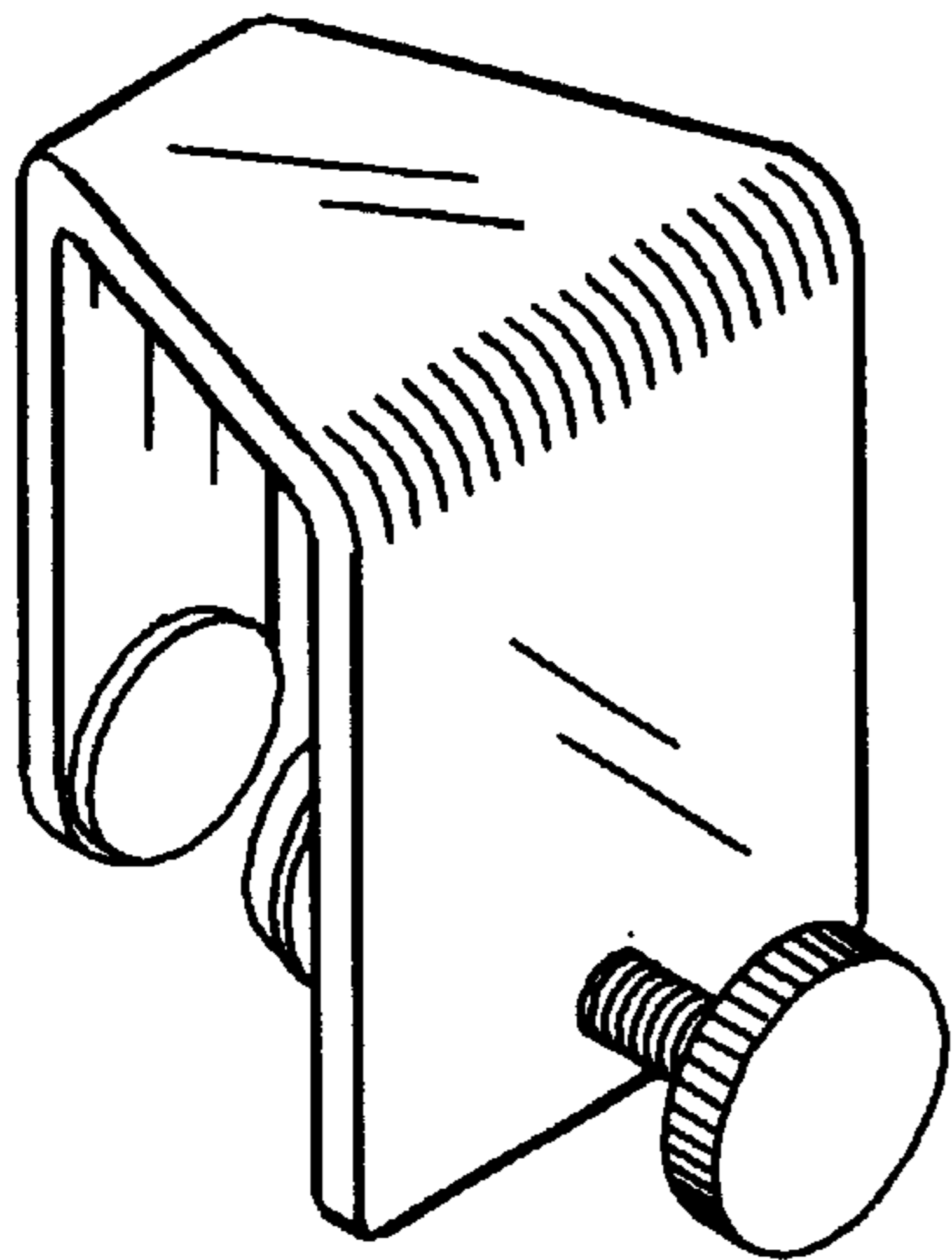

FIG. 2

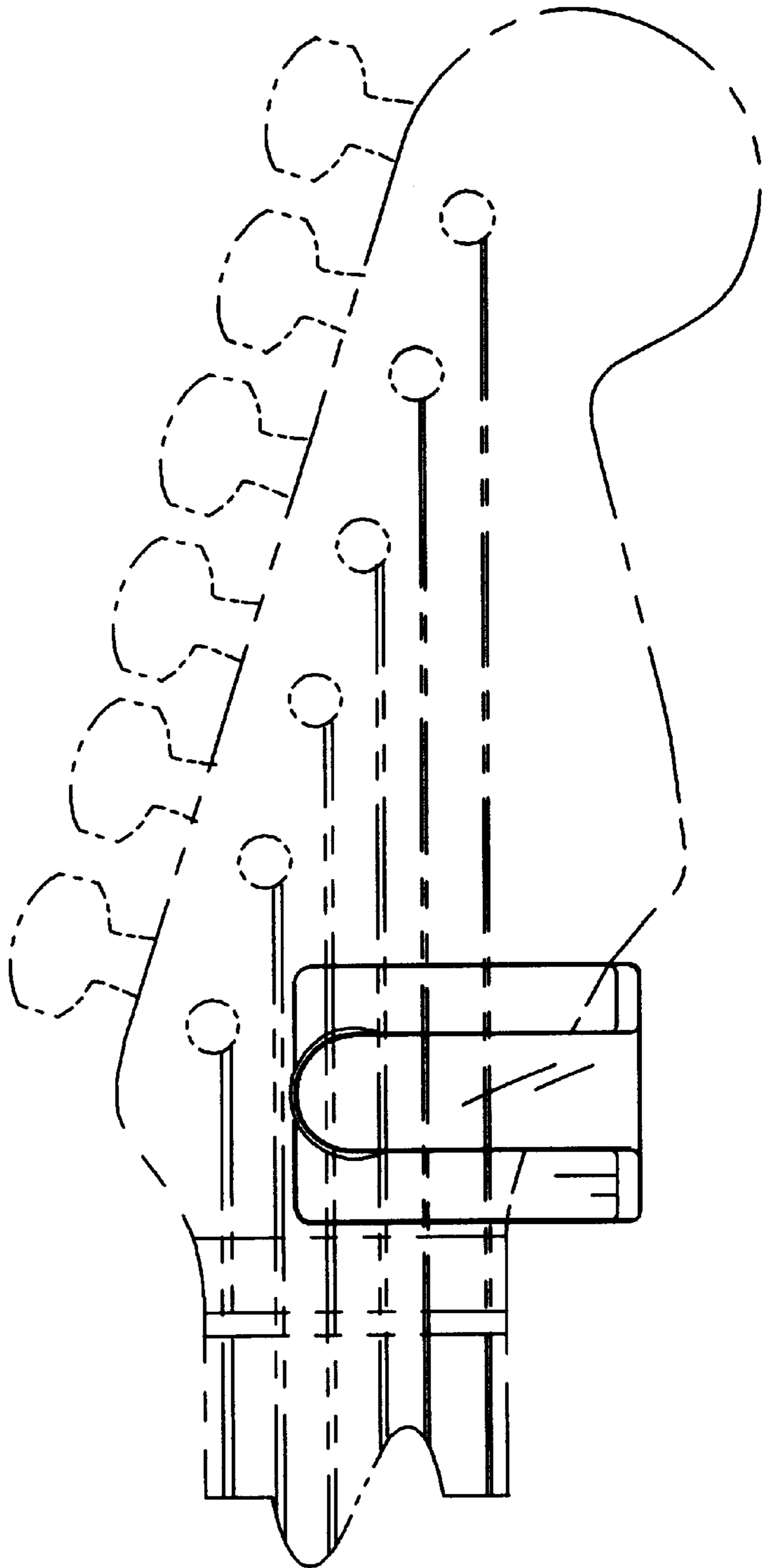

FIG. 3

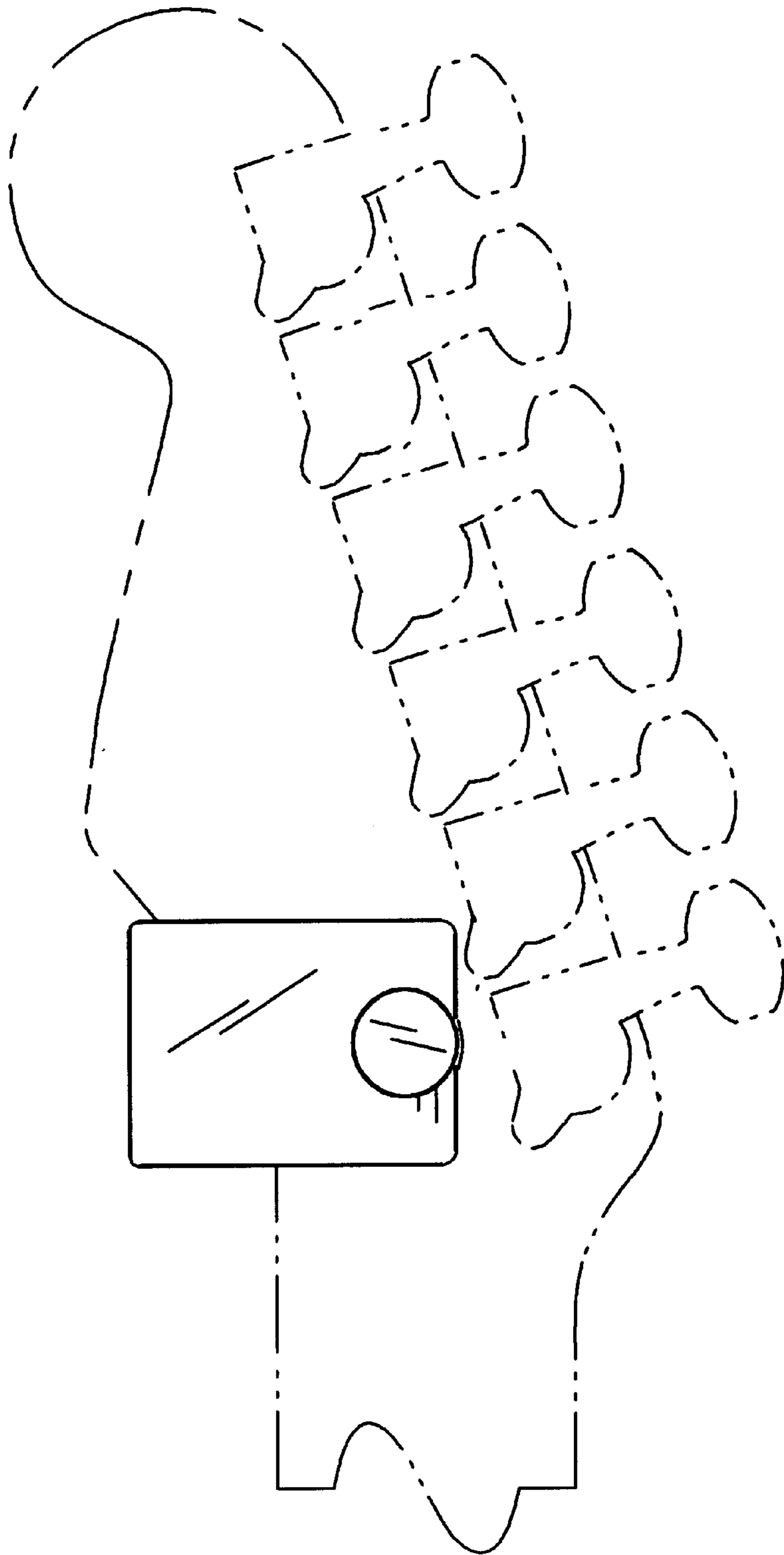

FIG. 4

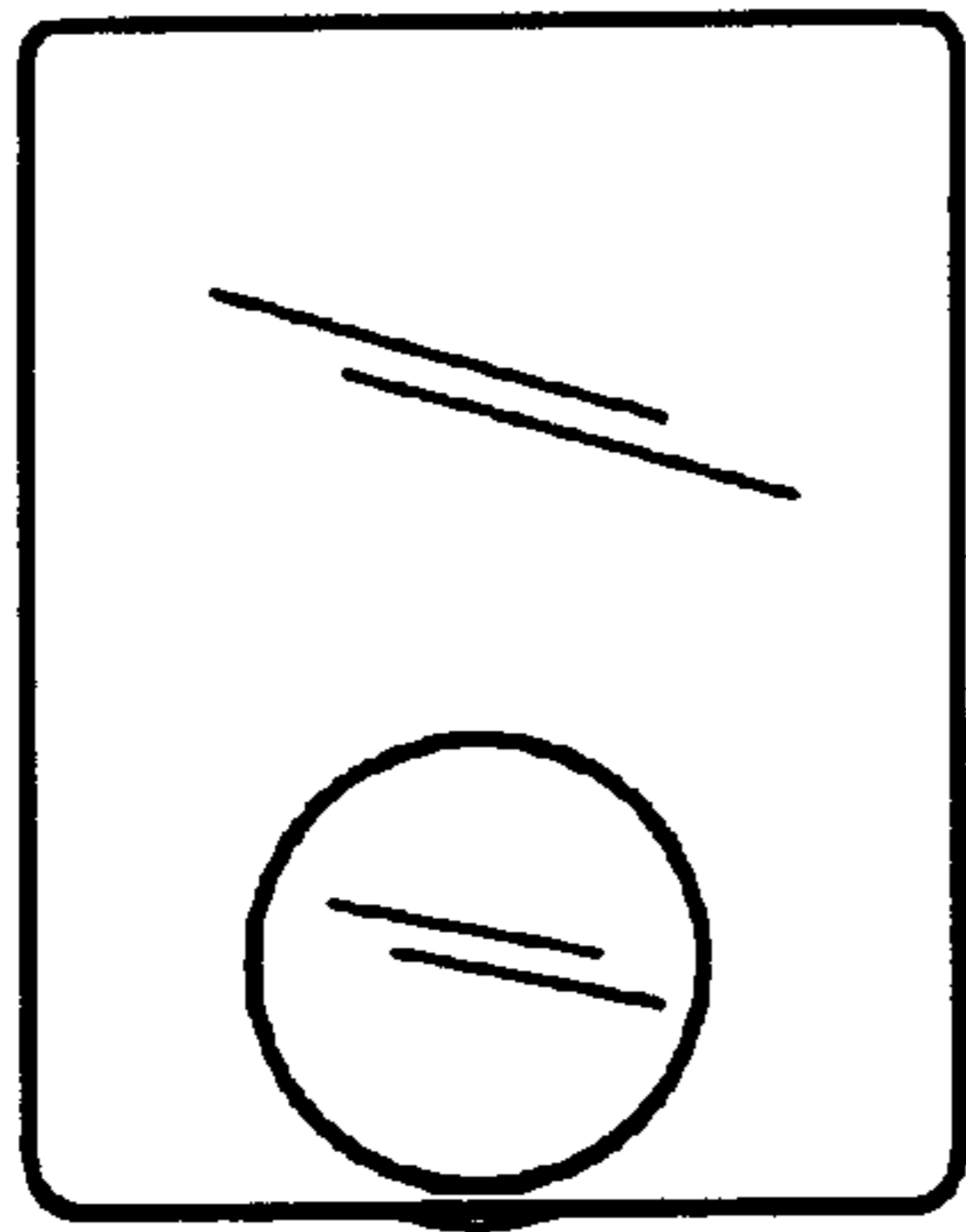

FIG. 5

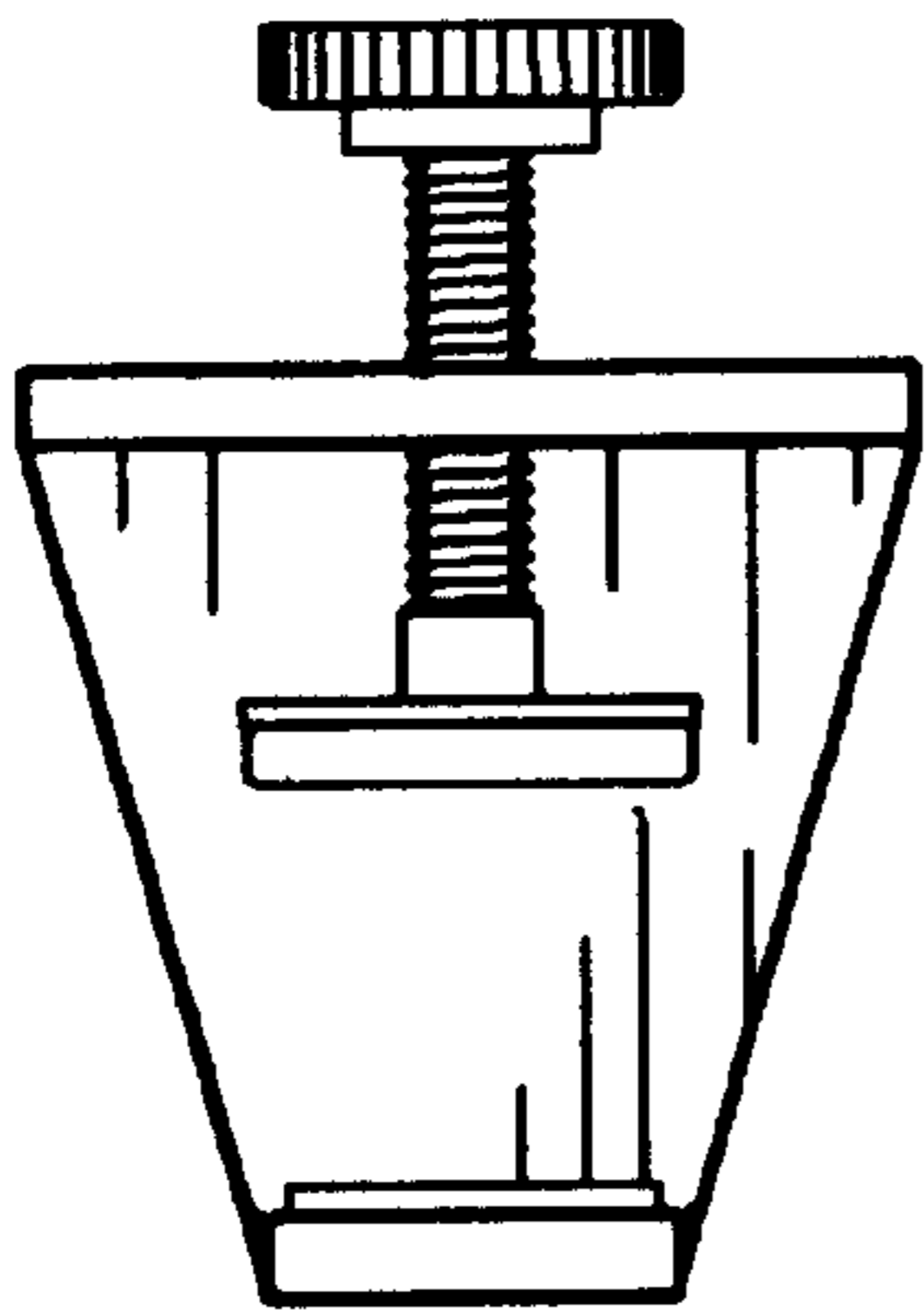

FIG. 6

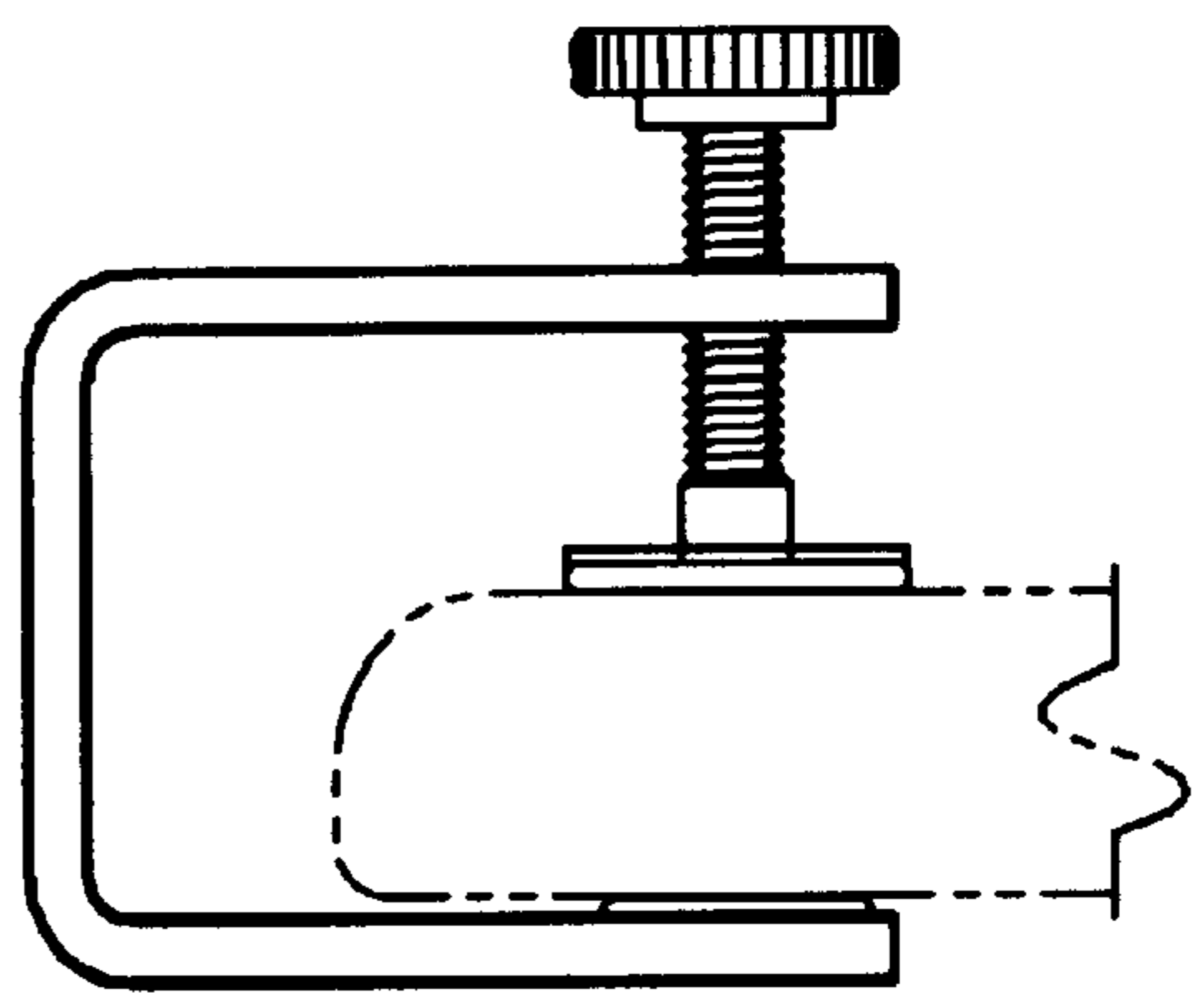

FIG. 7

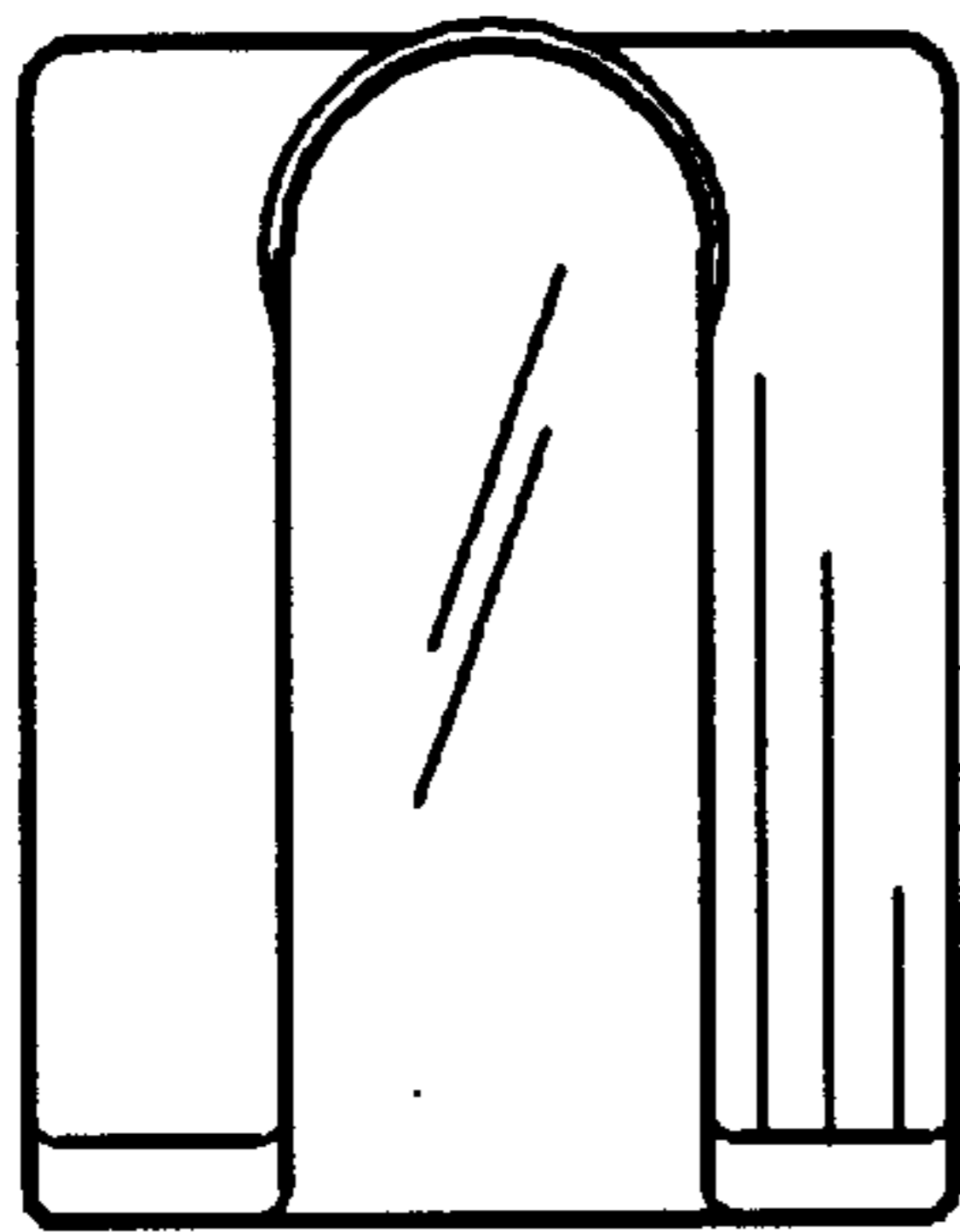

FIG. 8

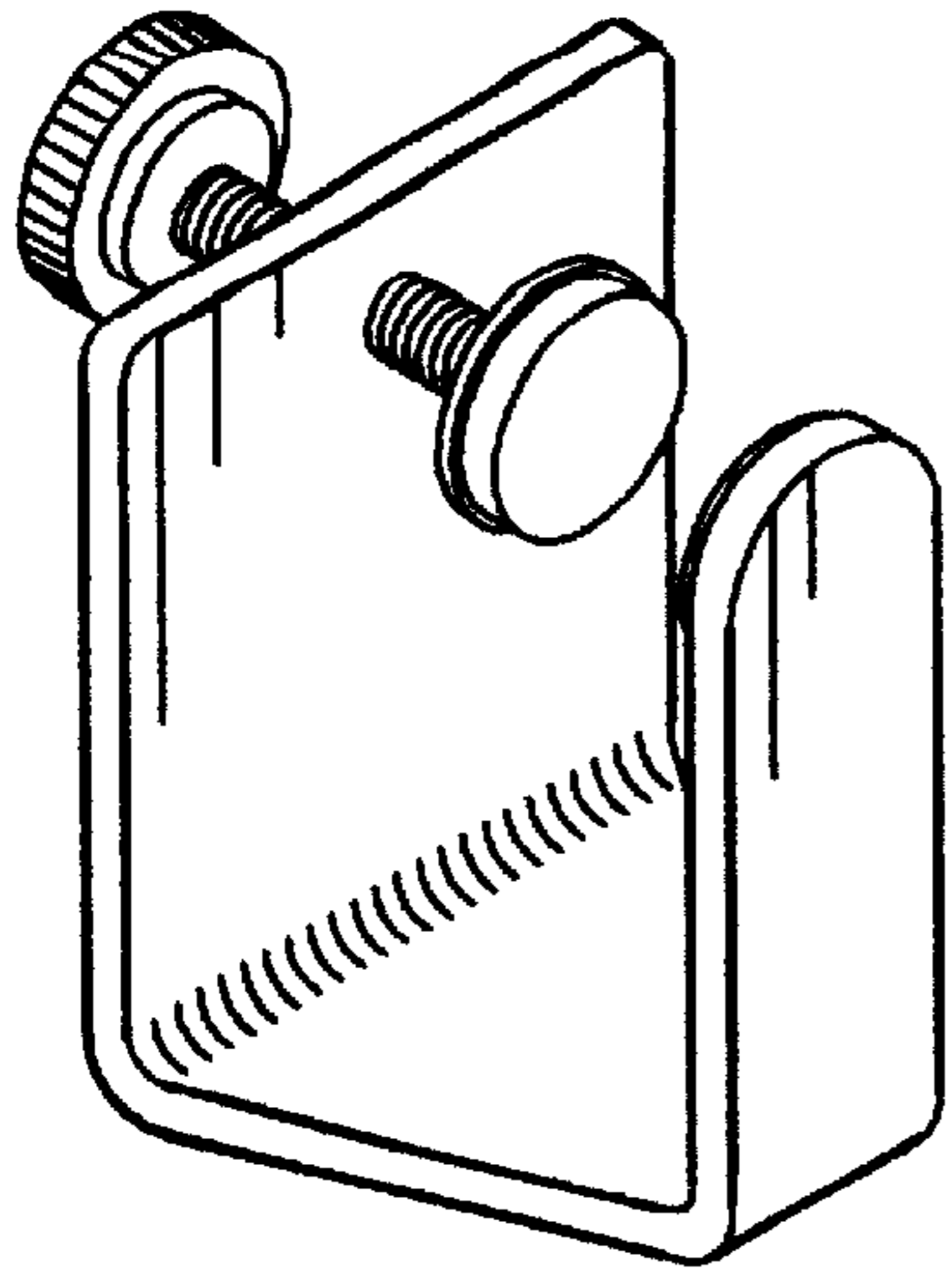

FIG. 9

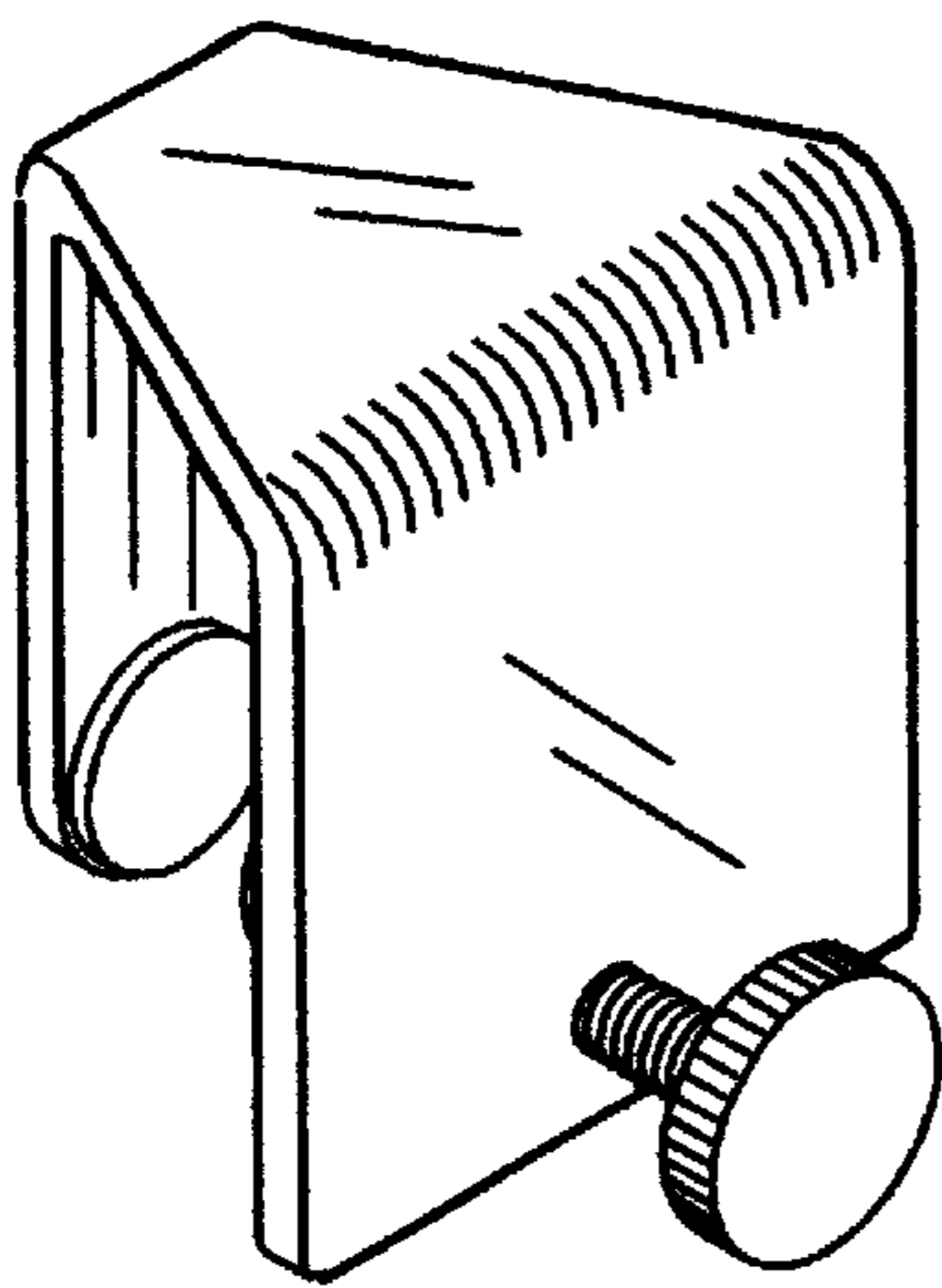

FIG. 10

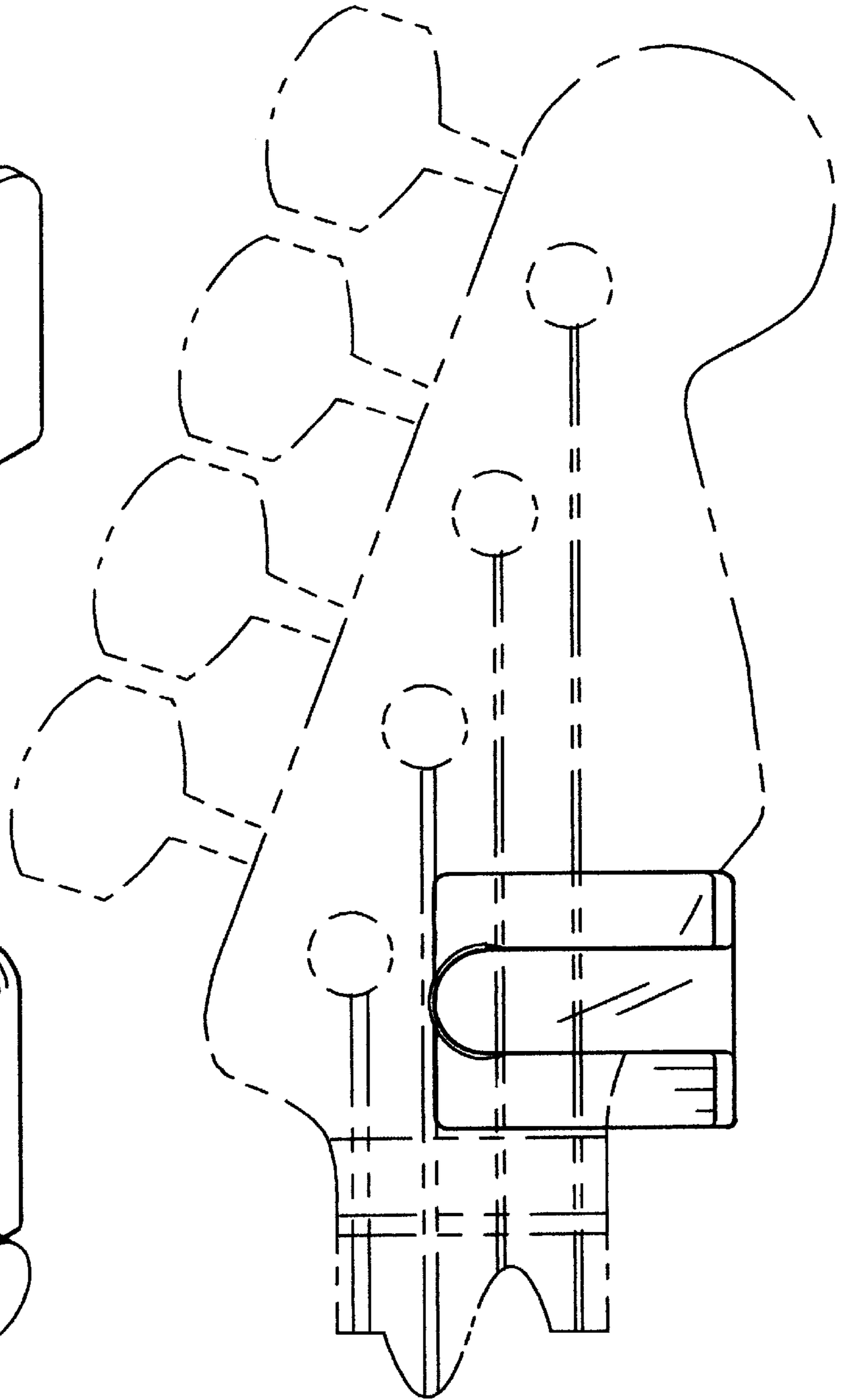

FIG. 11

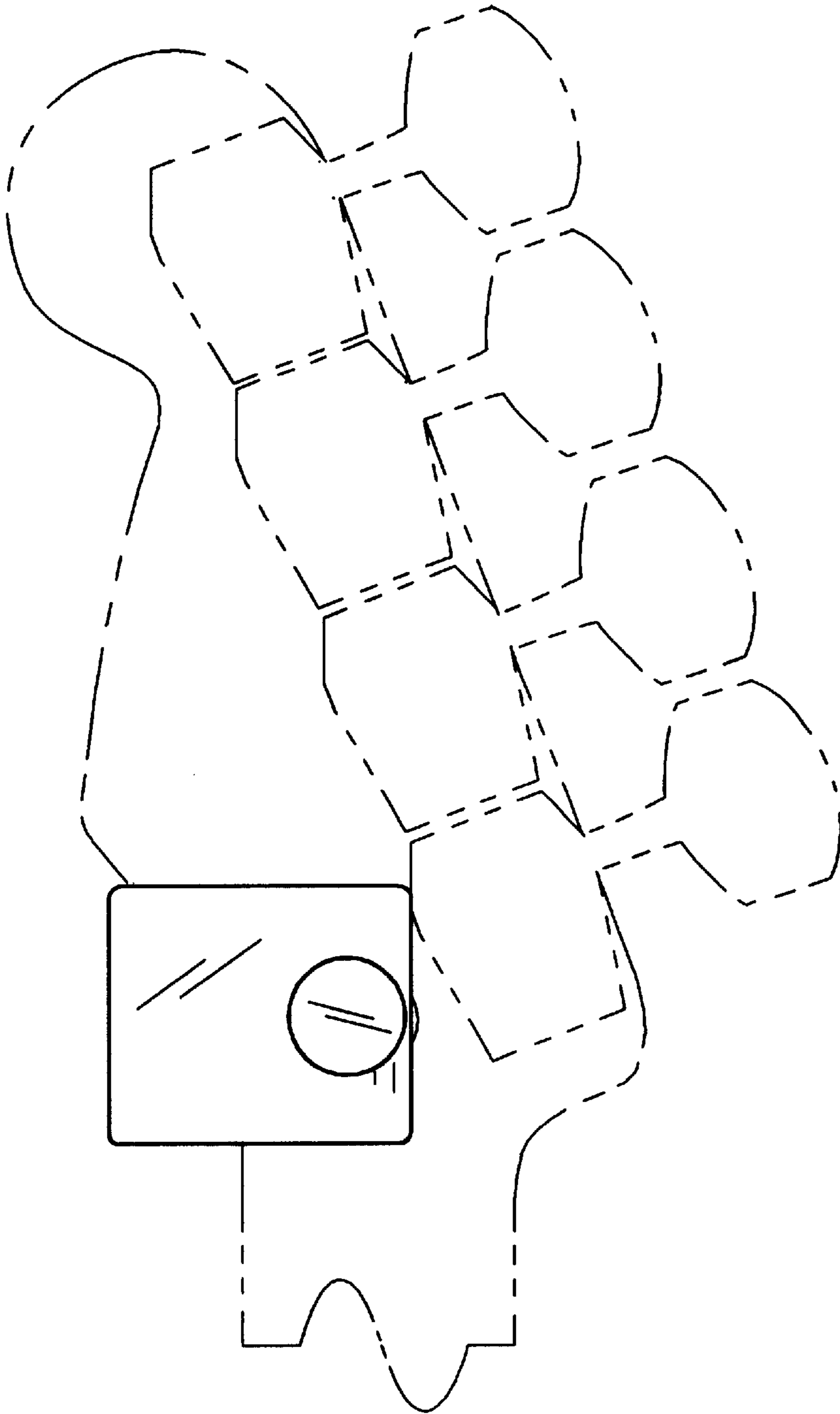

FIG. 12

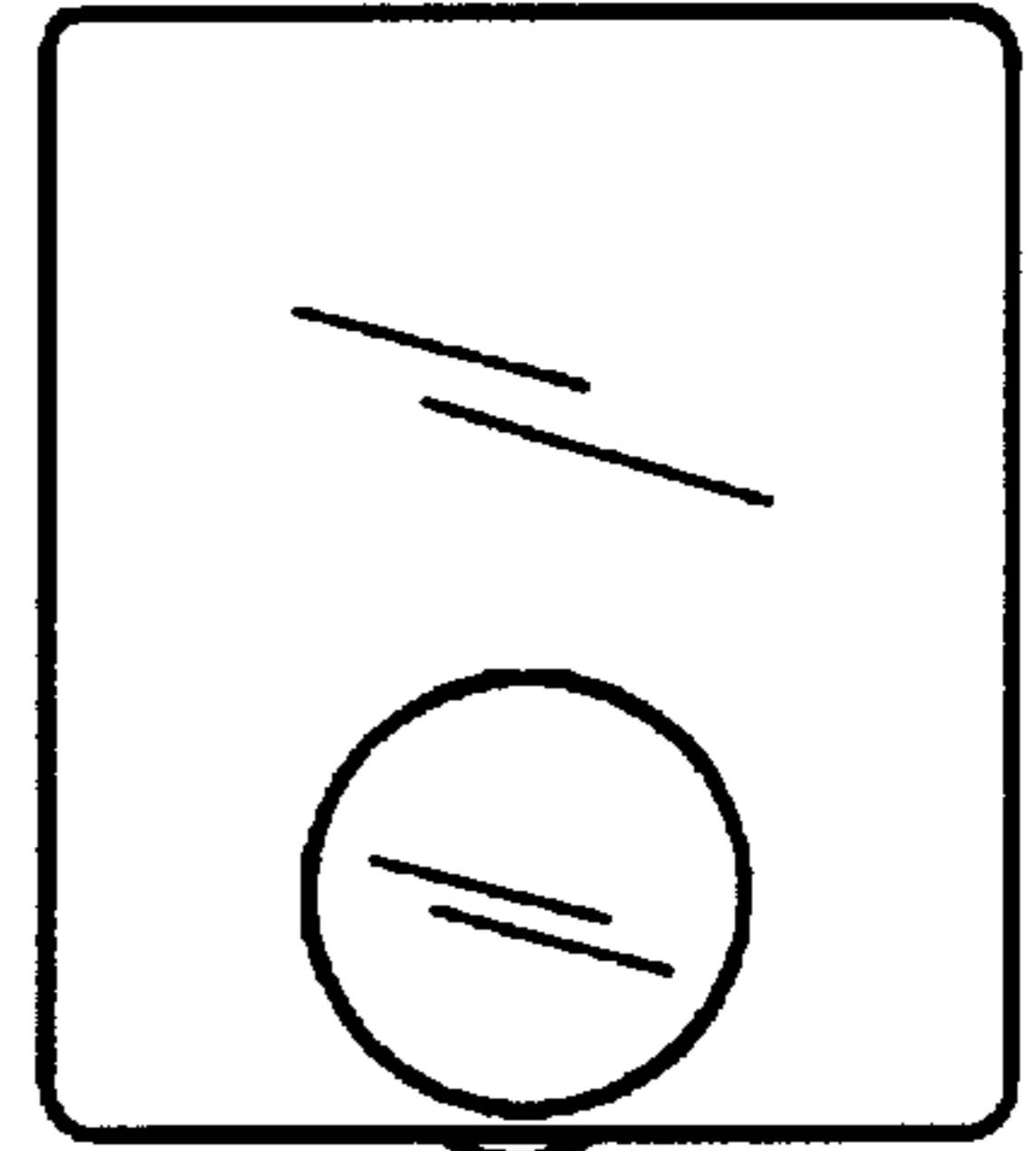

FIG. 13

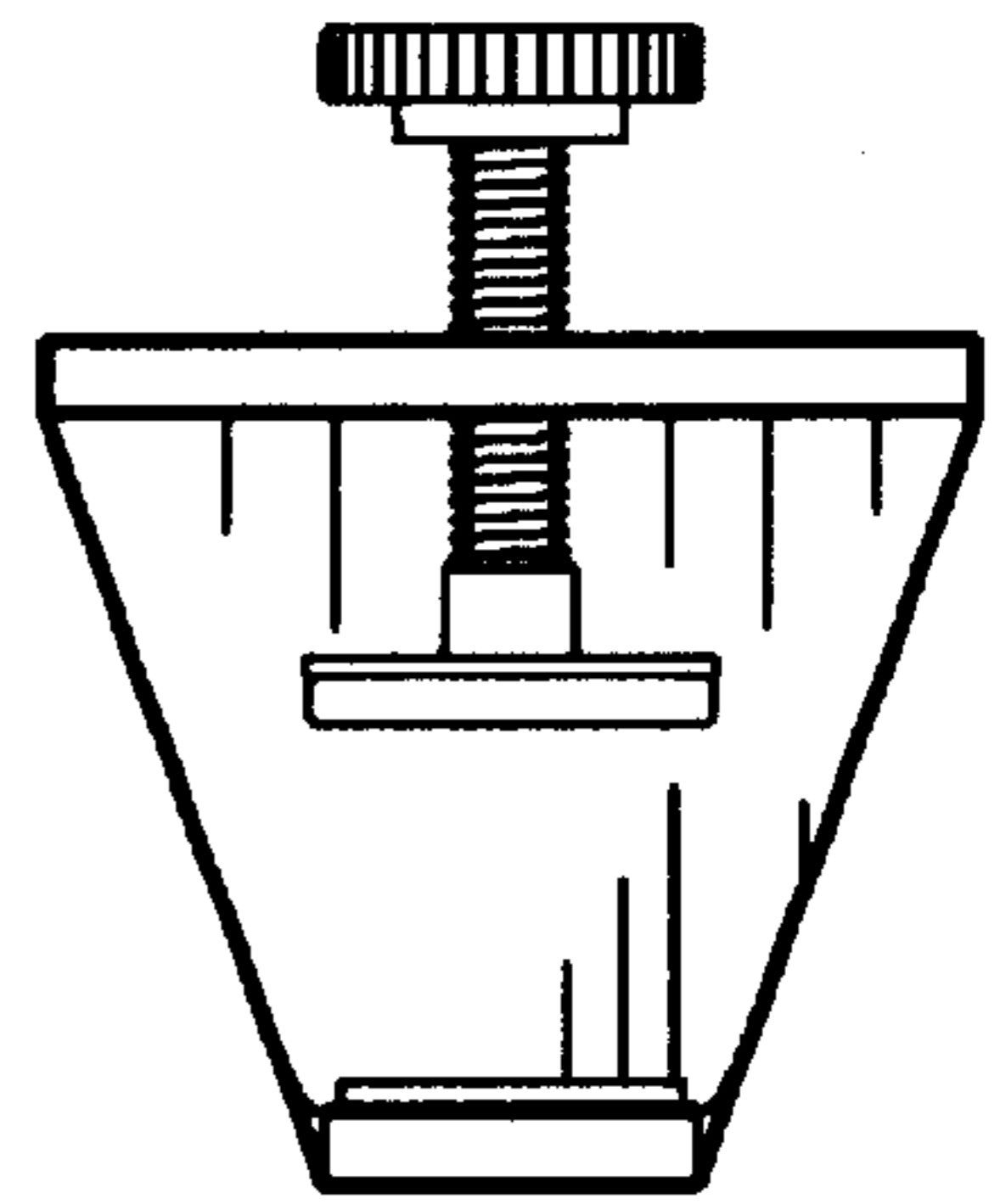

FIG. 14

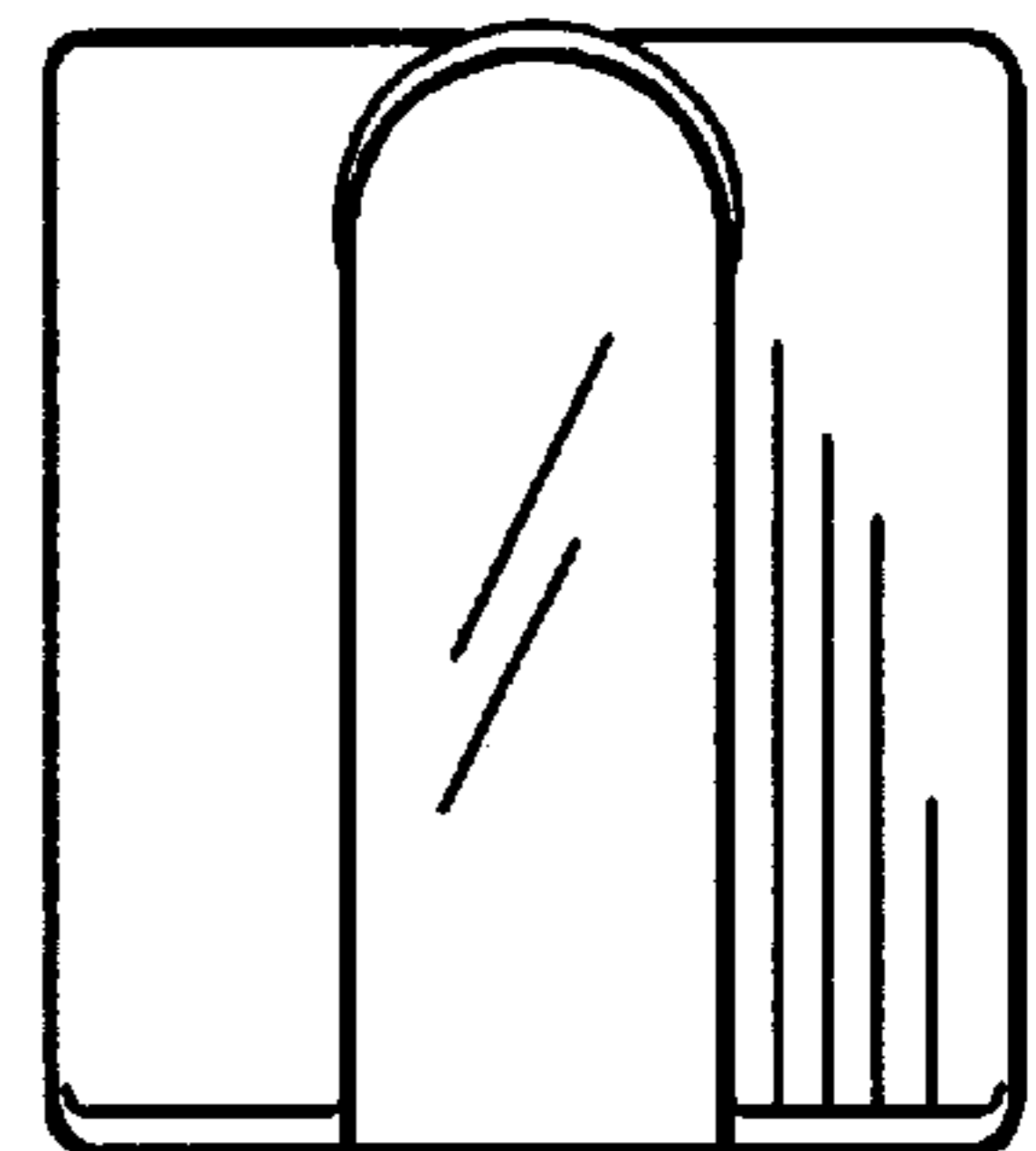

FIG. 15