



US00D481703S

(12) **United States Design Patent**
Togawa et al.

(10) **Patent No.:** **US D481,703 S**

(45) **Date of Patent:** **** Nov. 4, 2003**

(54) **RADIO RECEIVER FOR CARS**

Primary Examiner—Prabhakar Deshmukh

(75) Inventors: **Shinichi Togawa**, Kyoto (JP); **Yasuhide Tanaka**, Kyoto (JP); **Katsuji Matsushita**, Kyoto (JP)

(74) *Attorney, Agent, or Firm*—Dickstein Shapiro Morin & Oshinsky LLP

(73) Assignee: **Omron Corporation**, Kyoto (JP)

(57) **CLAIM**

(**) Term: **14 Years**

The ornamental design for a radio receiver for cars, as shown and described.

(21) Appl. No.: **29/156,744**

DESCRIPTION

(22) Filed: **Mar. 7, 2002**

(30) **Foreign Application Priority Data**

Oct. 12, 2001 (JP) 2001-030057

(51) **LOC (7) Cl.** **14-03**

(52) **U.S. Cl.** **D14/157**

(58) **Field of Search** D14/156, 157, D14/160, 162, 164, 168, 188, 197, 198, 225, 226, 257, 258, 265; 369/75.1, 75.2, 77.1, 77.2; 455/844, 347, 348, 350, 351

FIG. 1 is a front view showing my new design for a radio receiver for cars;

FIG. 2 is a rear view of the radio receiver for cars of FIG. 1;

FIG. 3 is a right side view of the radio receiver for cars of FIG. 1;

FIG. 4 is a left side view of the radio receiver for cars of FIG. 1;

FIG. 5 is a top view of the radio receiver for cars of FIG. 1;

FIG. 6 is a bottom view of the radio receiver for cars of FIG. 1;

FIG. 7 is a perspective view of the radio receiver for cars of FIG. 1;

FIG. 8 is a second perspective view of the radio receiver for cars of FIG. 1;

FIG. 9 is a third perspective view of the radio receiver for cars of FIG. 1; and,

FIG. 10 is a reference perspective view showing a state of use of the radio receiver for cars of FIG. 1.

The broken lines in FIG. 10 are for illustrative purpose only and form no part of the claimed design.

(56) **References Cited**

U.S. PATENT DOCUMENTS

4,676,619	A	*	6/1987	Woolley	455/344
4,940,414	A	*	7/1990	Lee	D14/157 X
5,146,618	A	*	9/1992	Wenner	455/347
D335,495	S	*	5/1993	Lee	D14/157
5,285,500	A	*	2/1994	Mantz	455/346
D360,206	S	*	7/1995	Williams	D14/157
D407,705	S	*	4/1999	Bryant	D14/157
D450,678	S	*	11/2001	Mizokawa et al.	D14/157
D453,505	S	*	2/2002	Davis et al.	D14/157

* cited by examiner

1 Claim, 5 Drawing Sheets

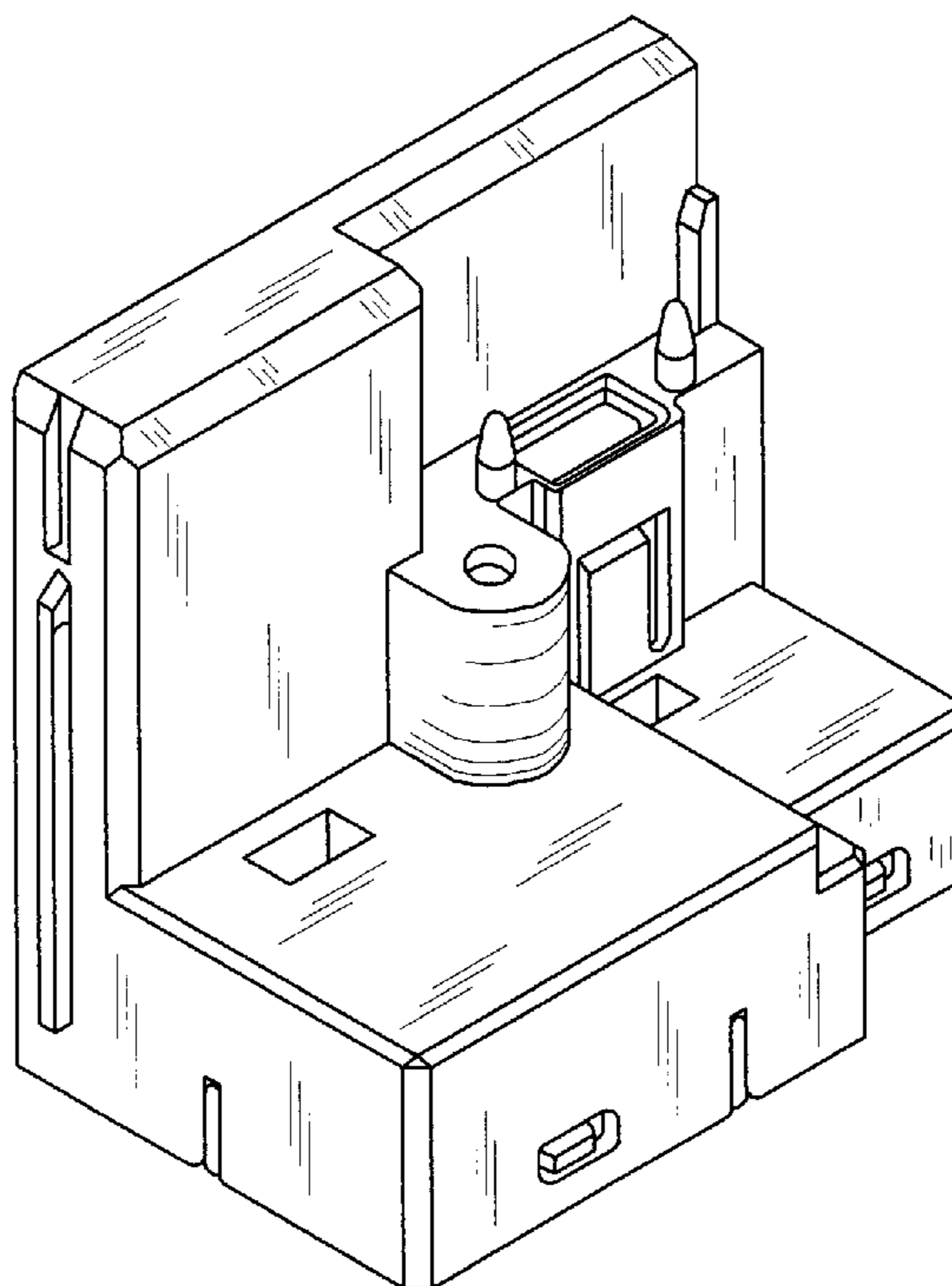

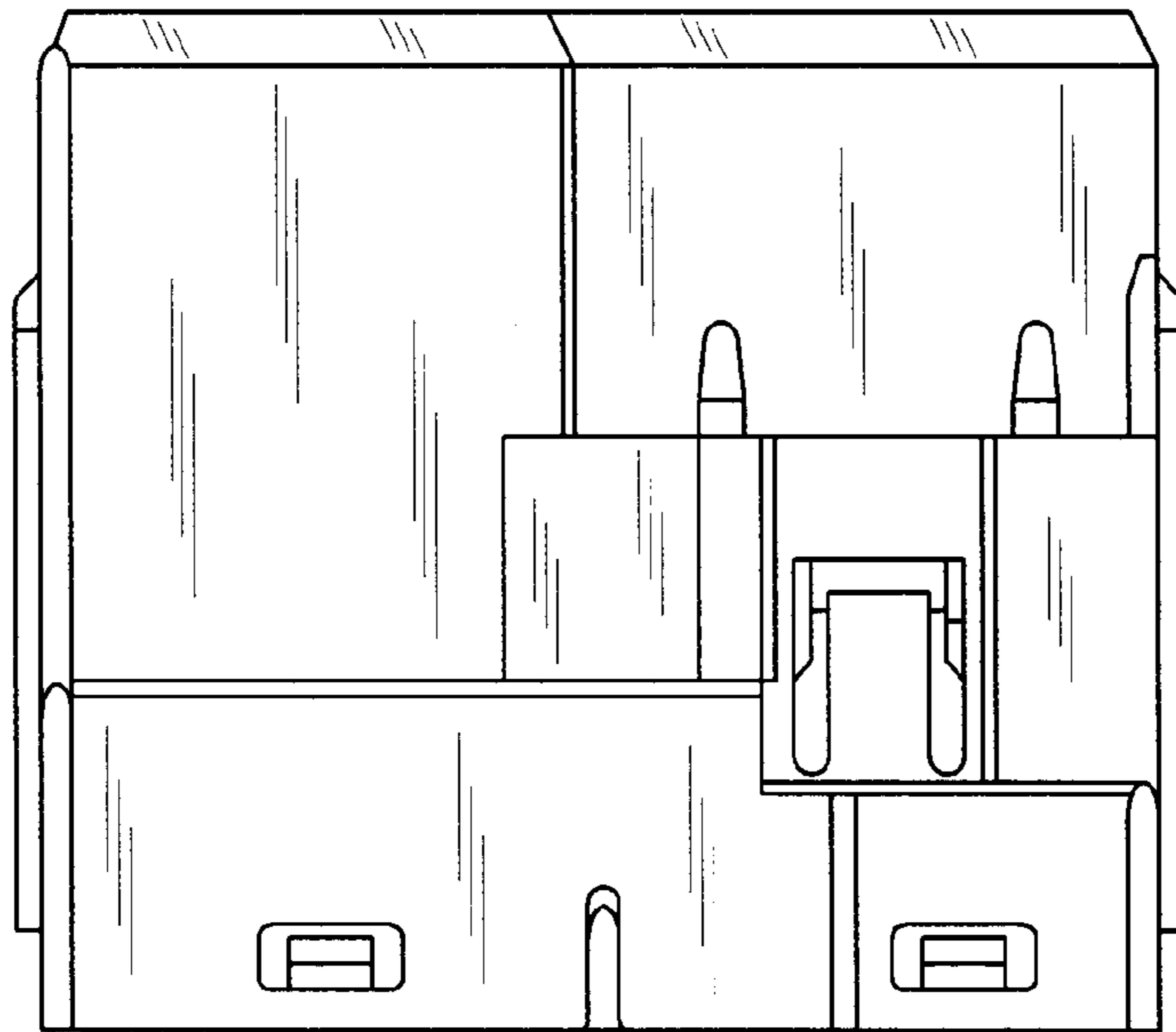

FIG. 1

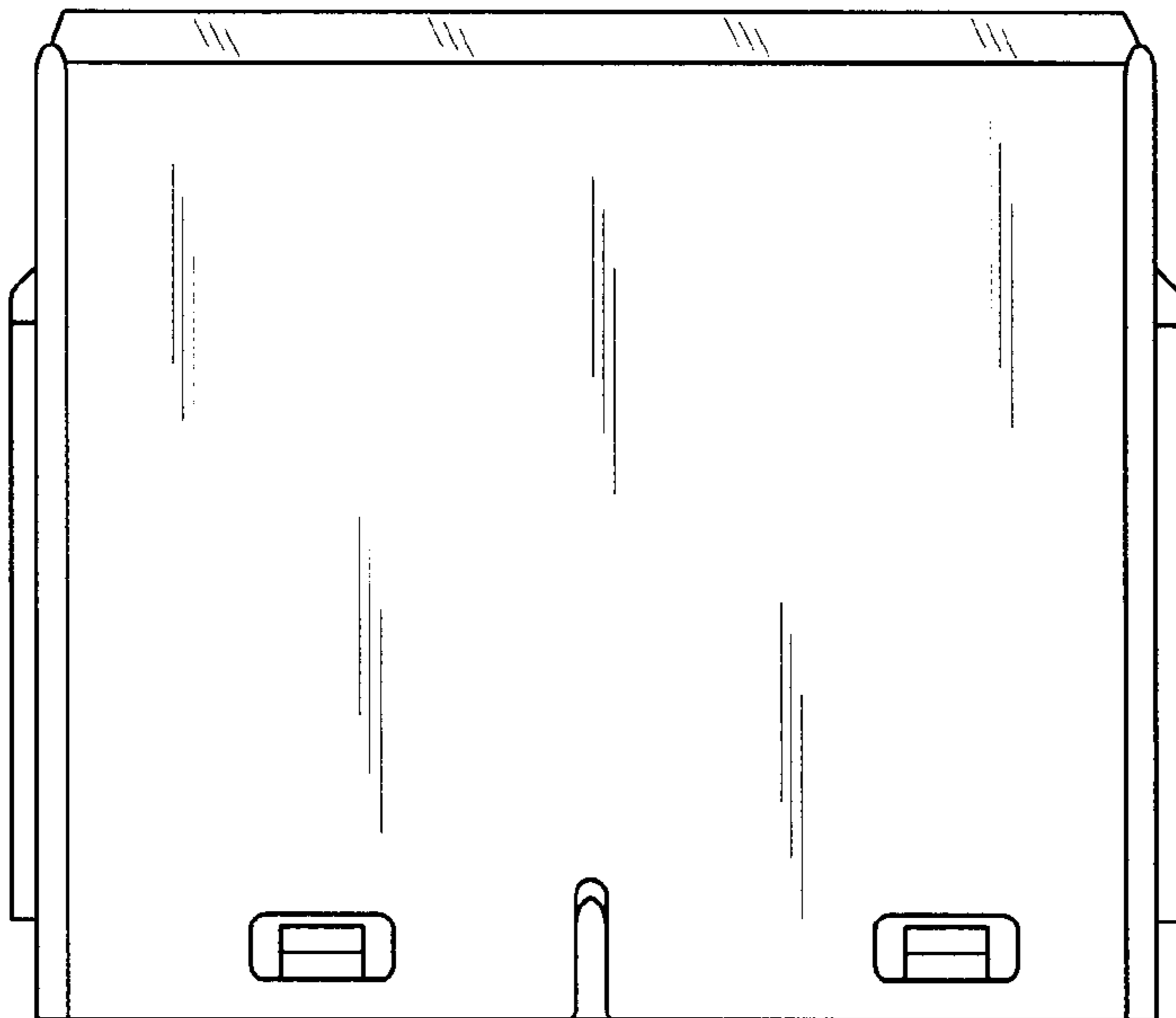

FIG. 2

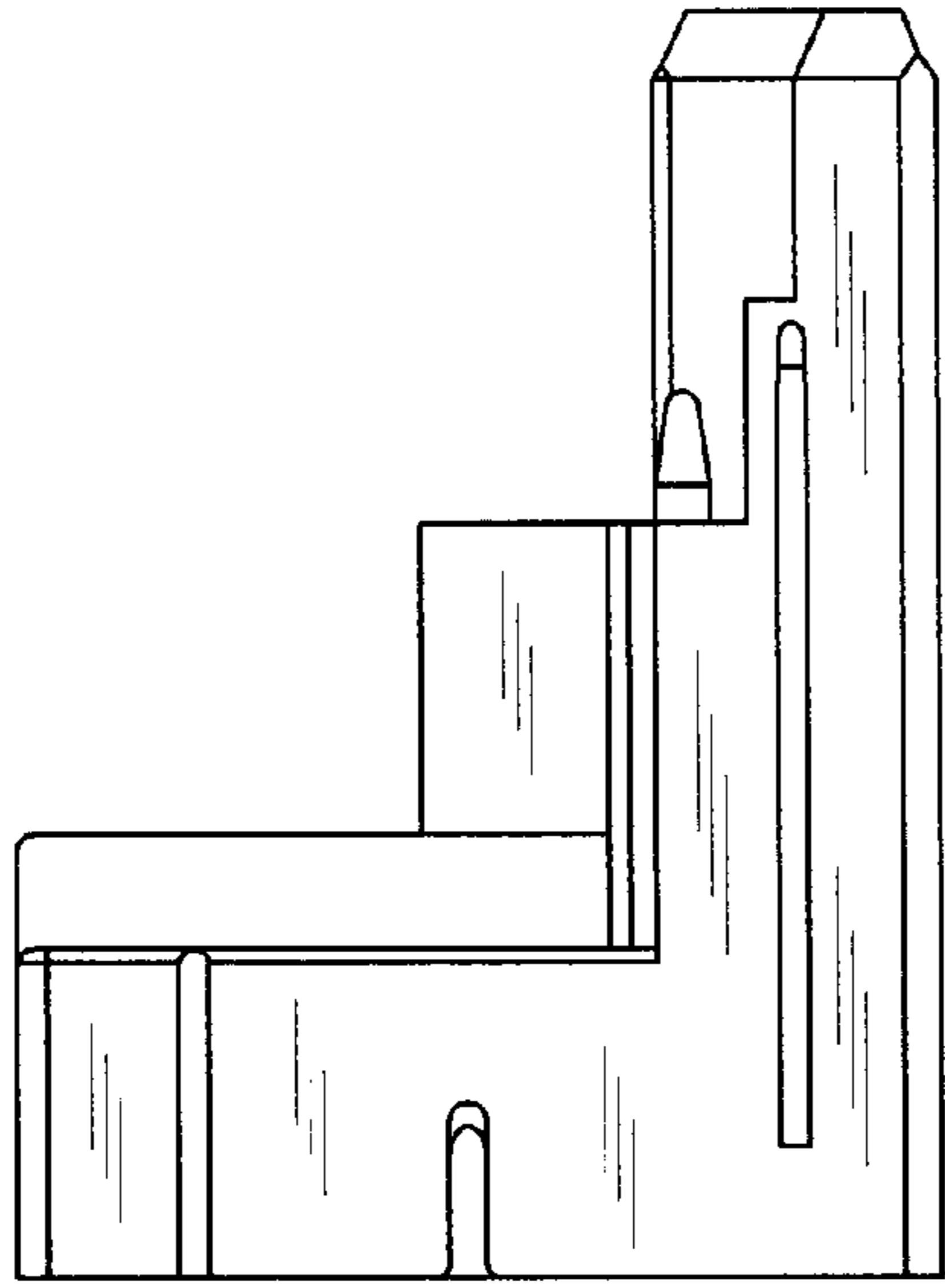

FIG. 3

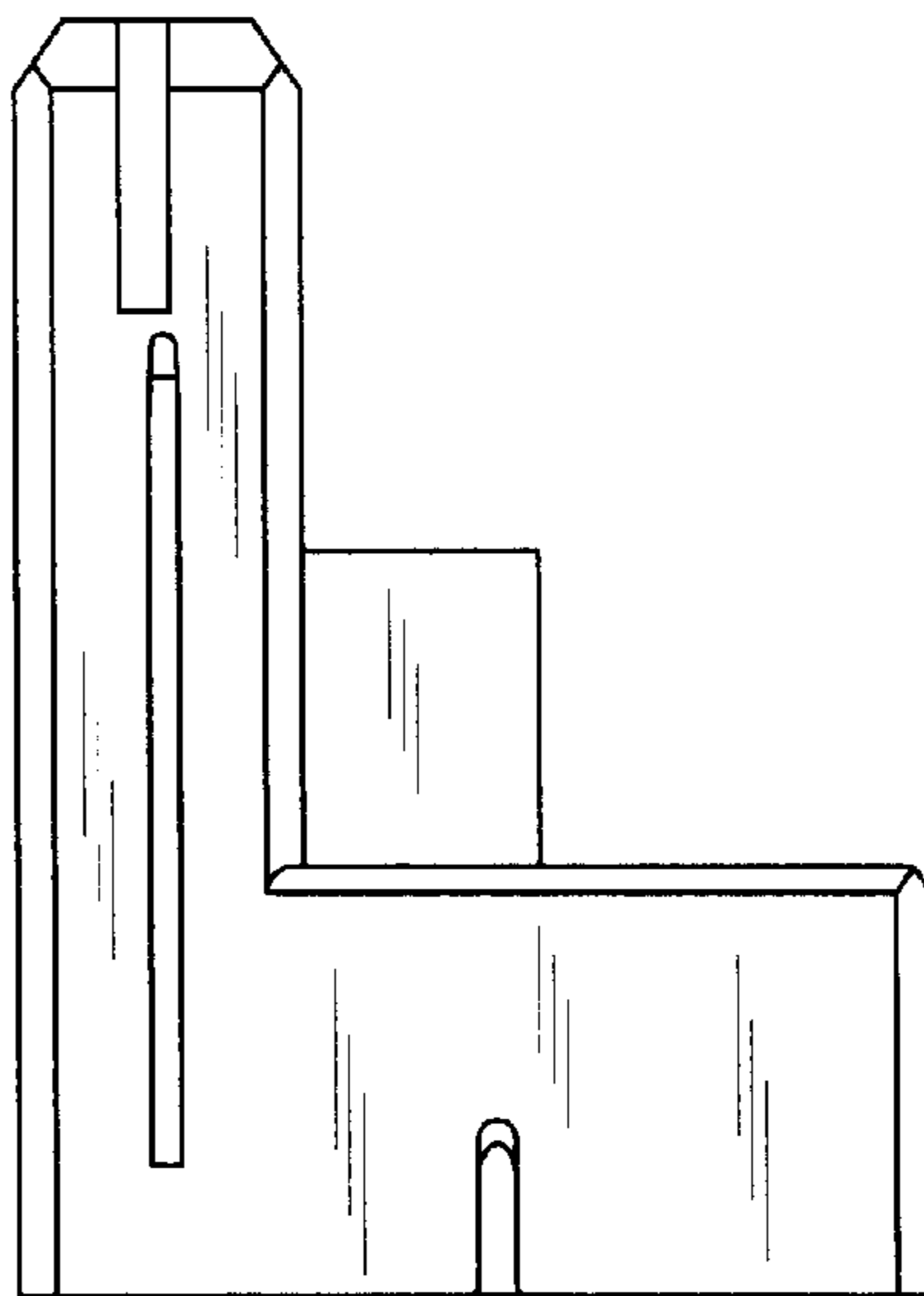

FIG. 4

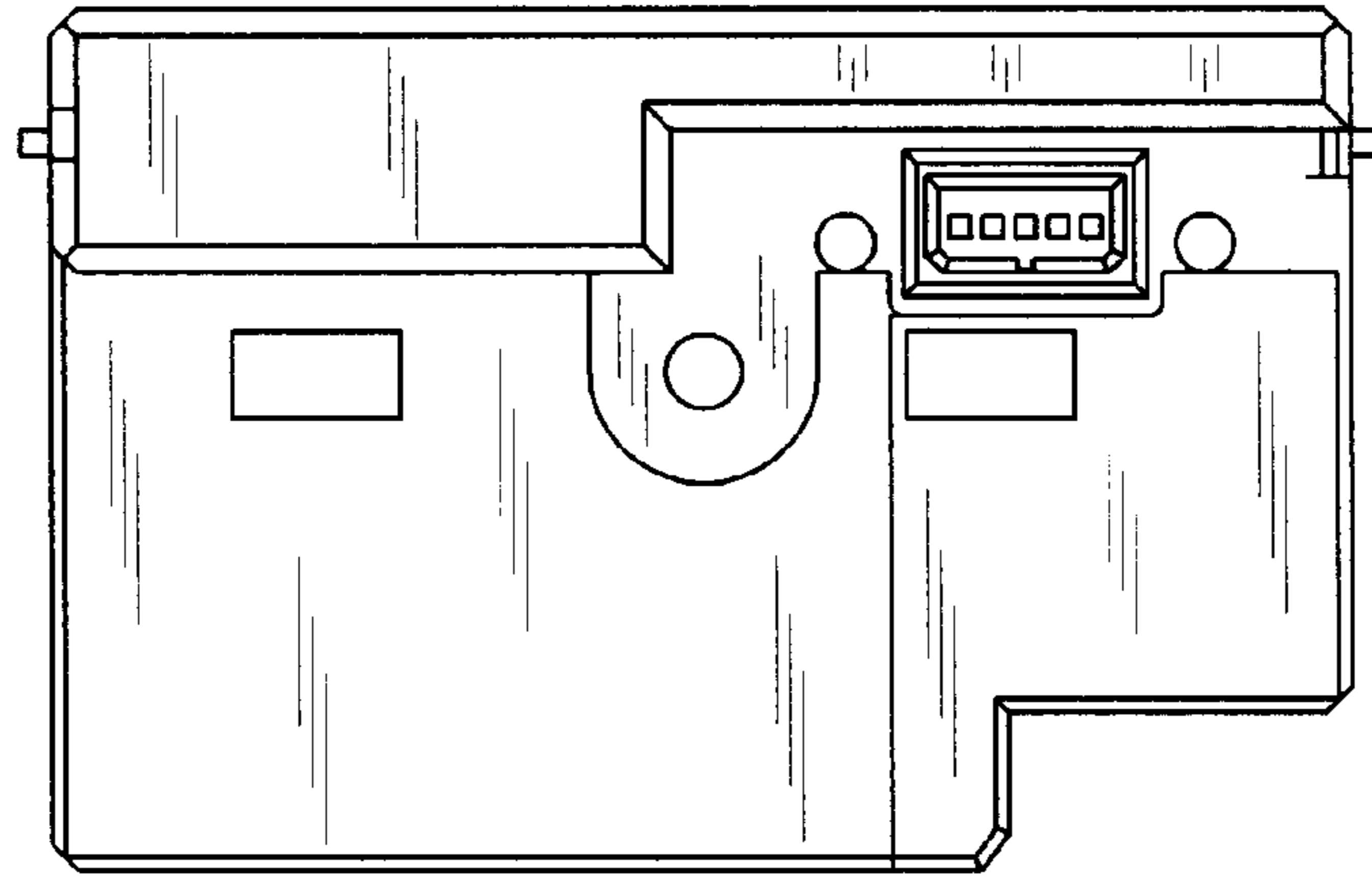

FIG. 5

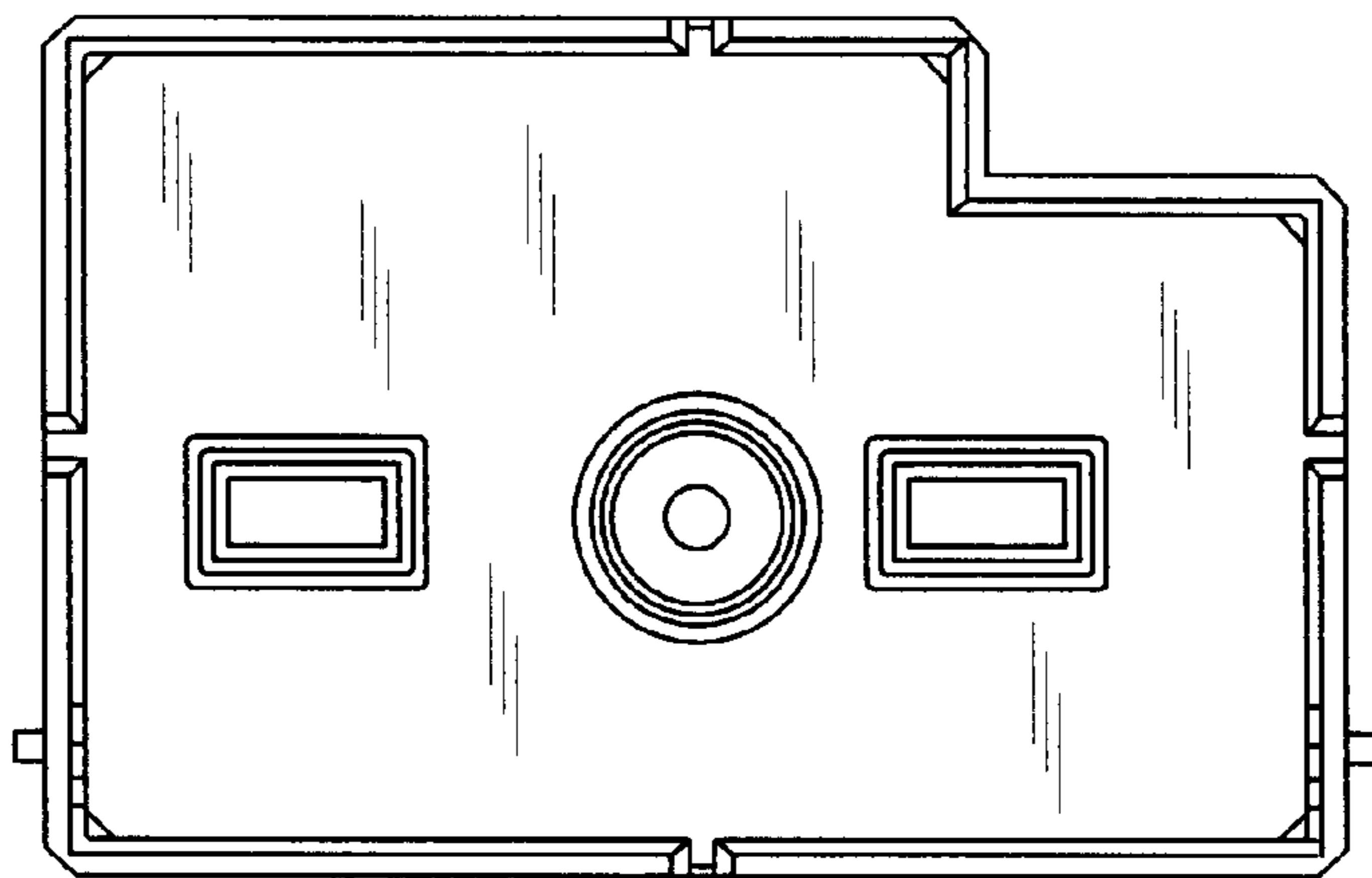

FIG. 6

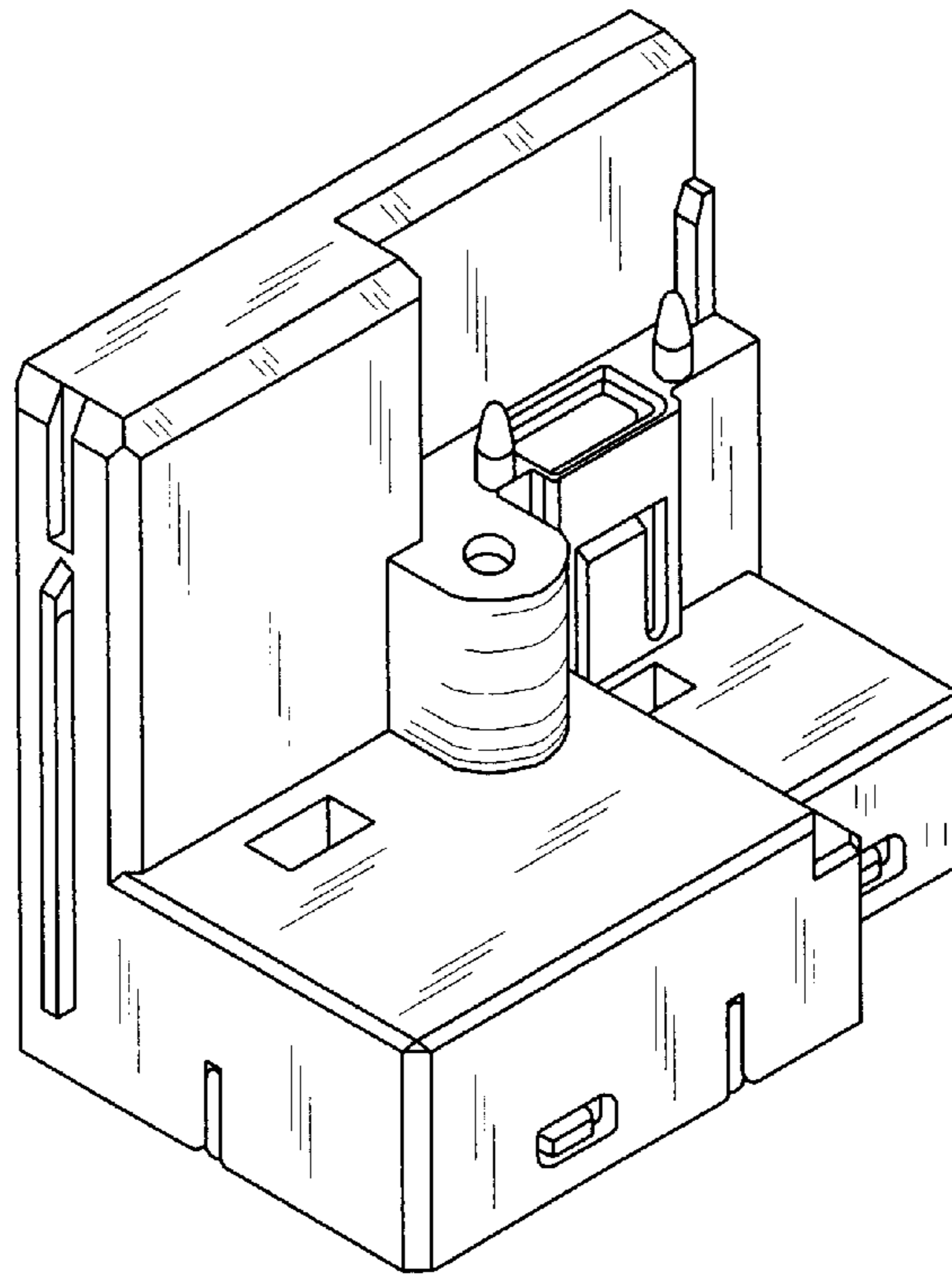

FIG. 7

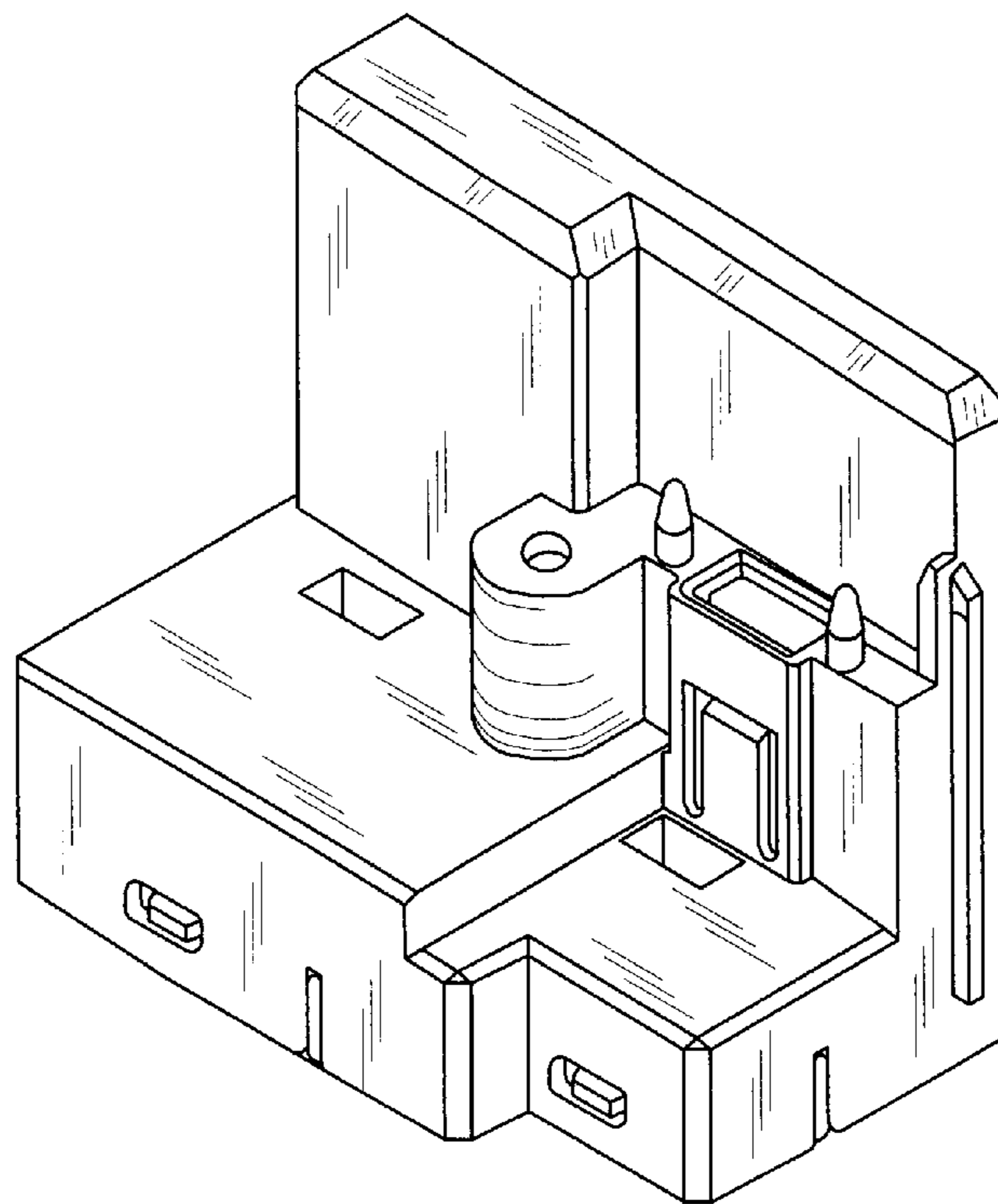

FIG. 8

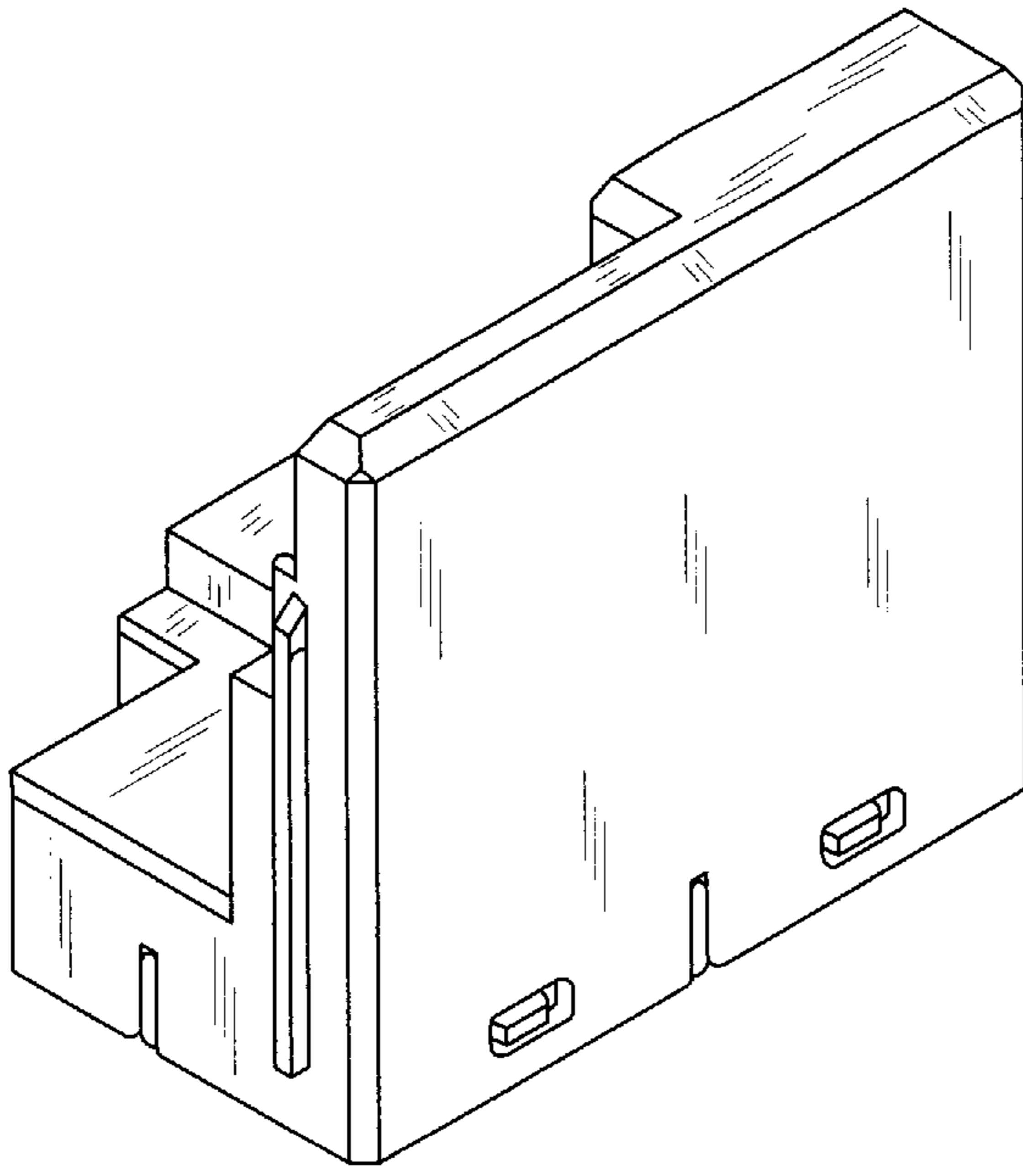

FIG. 9

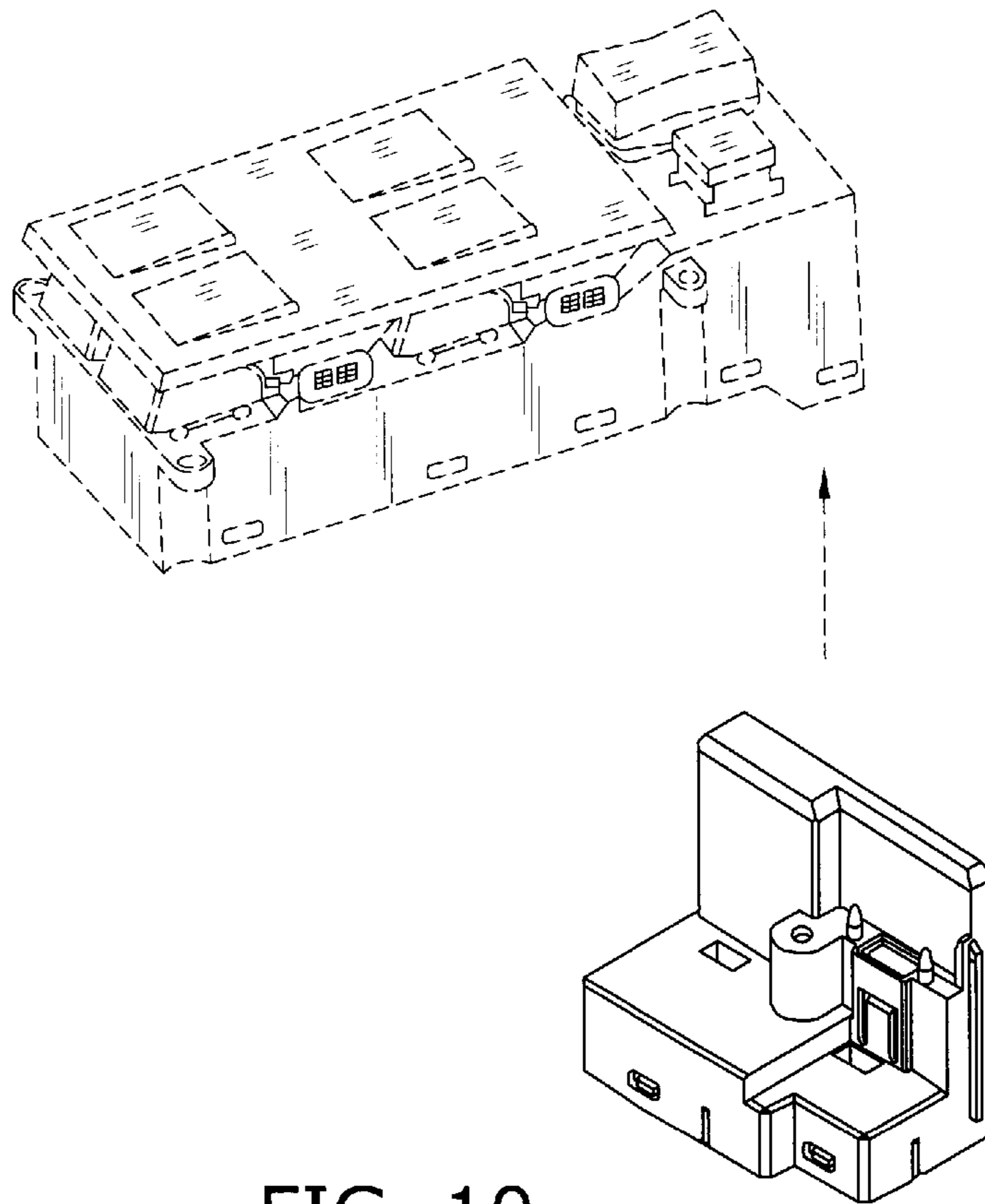

FIG. 10