



US00D481672S

(12) **United States Design Patent**  
**Niwa et al.**

(10) **Patent No.:** **US D481,672 S**

(45) **Date of Patent:** **\*\* Nov. 4, 2003**

(54) **BATTERY PACK**

(75) Inventors: **Norifumi Niwa, Anjo (JP); Kazuma Oshima, Anjo (JP); Shinsuke Okuda, Anjo (JP)**

(73) Assignee: **Makita Corporation, Anjo (JP)**

(\*\*) Term: **14 Years**

(21) Appl. No.: **29/177,471**

(22) Filed: **Mar. 12, 2003**

**Related U.S. Application Data**

(62) Division of application No. 29/163,522, filed on Jul. 9, 2002.

(30) **Foreign Application Priority Data**

Jan. 9, 2002 (JP) ..... 2002-3854  
Jan. 9, 2002 (JP) ..... 2002-3855

(51) **LOC (7) Cl.** ..... **13-02**

(52) **U.S. Cl.** ..... **D13/103**

(58) **Field of Search** ..... D13/103; 429/96-100

(56) **References Cited**

**U.S. PATENT DOCUMENTS**

D304,026 S \* 10/1989 Goodner et al. .... D13/103  
D379,795 S \* 6/1997 Pitzen et al. .... D13/103  
5,881,823 A \* 3/1999 Kabatnik et al. .... 173/217  
D413,564 S \* 9/1999 Hershberger et al. .... D13/103

D415,100 S \* 10/1999 Buck ..... D13/103  
5,977,746 A \* 11/1999 Hershberger et al. .... 429/99 X  
6,127,063 A \* 10/2000 Kowalsky et al. .... 429/100  
6,346,793 B1 \* 2/2002 Shibata et al. .... 429/97 X  
6,350,149 B1 \* 2/2002 Nakane ..... 439/500  
6,501,197 B1 \* 12/2002 Cornog et al. .... 307/150

**FOREIGN PATENT DOCUMENTS**

JP 2001135290 \* 5/2001 ..... H01M/2/10  
JP 2001155700 \* 6/2001 ..... H01M/2/10

\* cited by examiner

*Primary Examiner*—Joel Sincavage

(74) *Attorney, Agent, or Firm*—Dennison, Schultz & Dougherty

(57) **CLAIM**

The ornamental design for a battery pack, as shown and described.

**DESCRIPTION**

FIG. 1 is a perspective view of a battery pack showing our new design.

FIG. 2 is a front elevation view thereof;

FIG. 3 is a rear elevation view thereof;

FIG. 4 is a left side elevation view thereof;

FIG. 5 is a right side elevation view thereof;

FIG. 6 is a top plan view thereof; and,

FIG. 7 is a bottom view thereof.

**1 Claim, 4 Drawing Sheets**

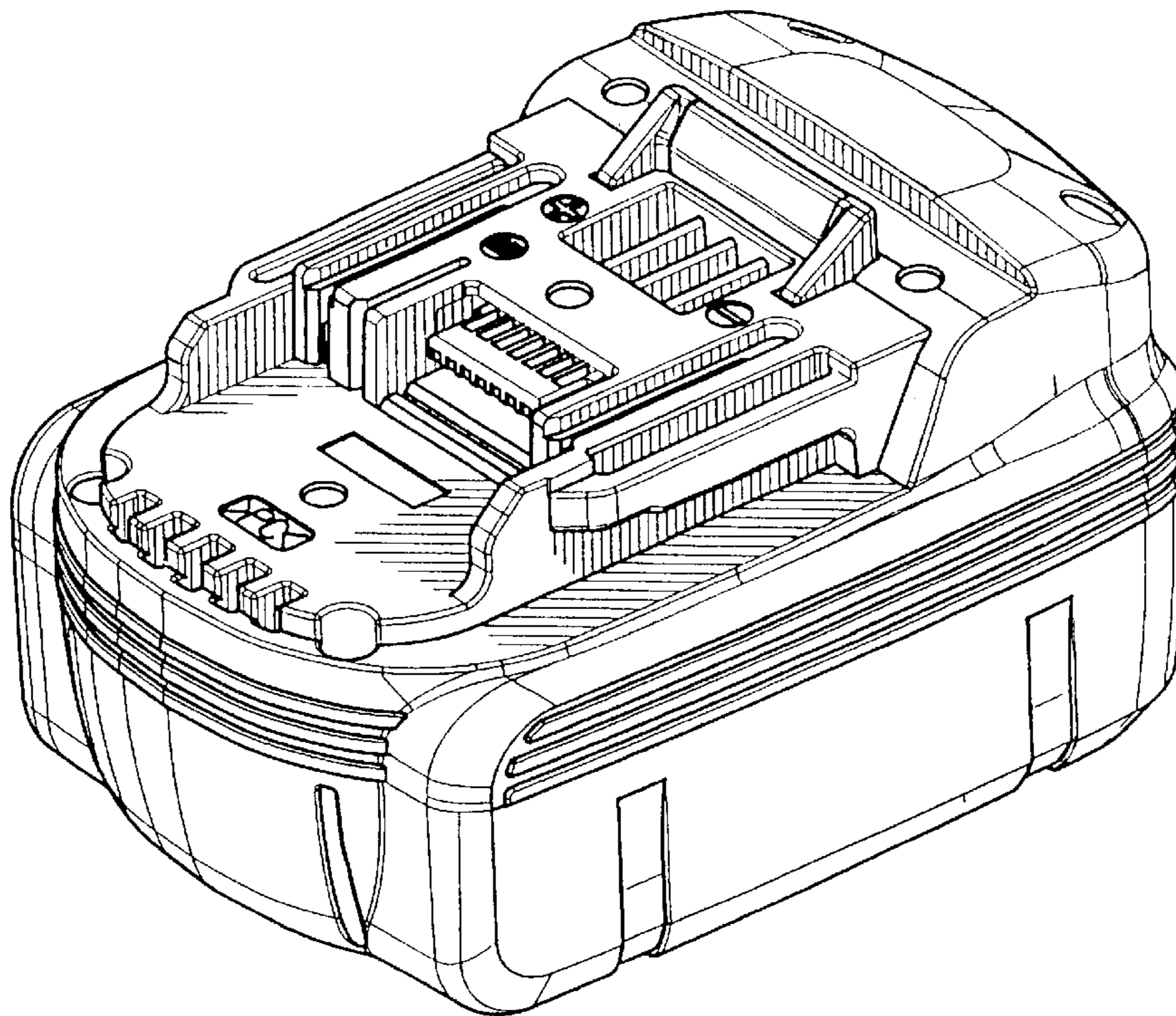

FIG. 1

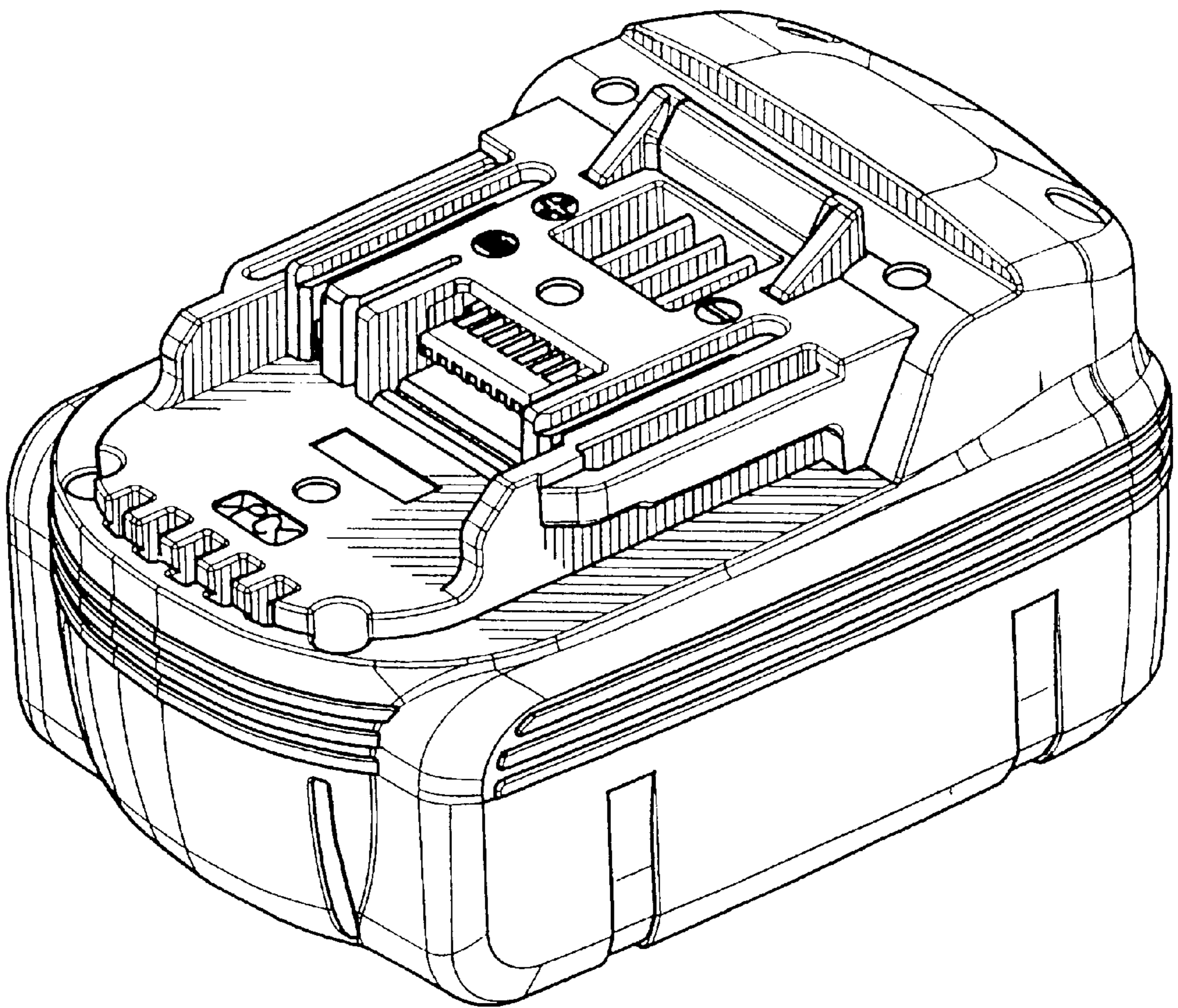

FIG. 2

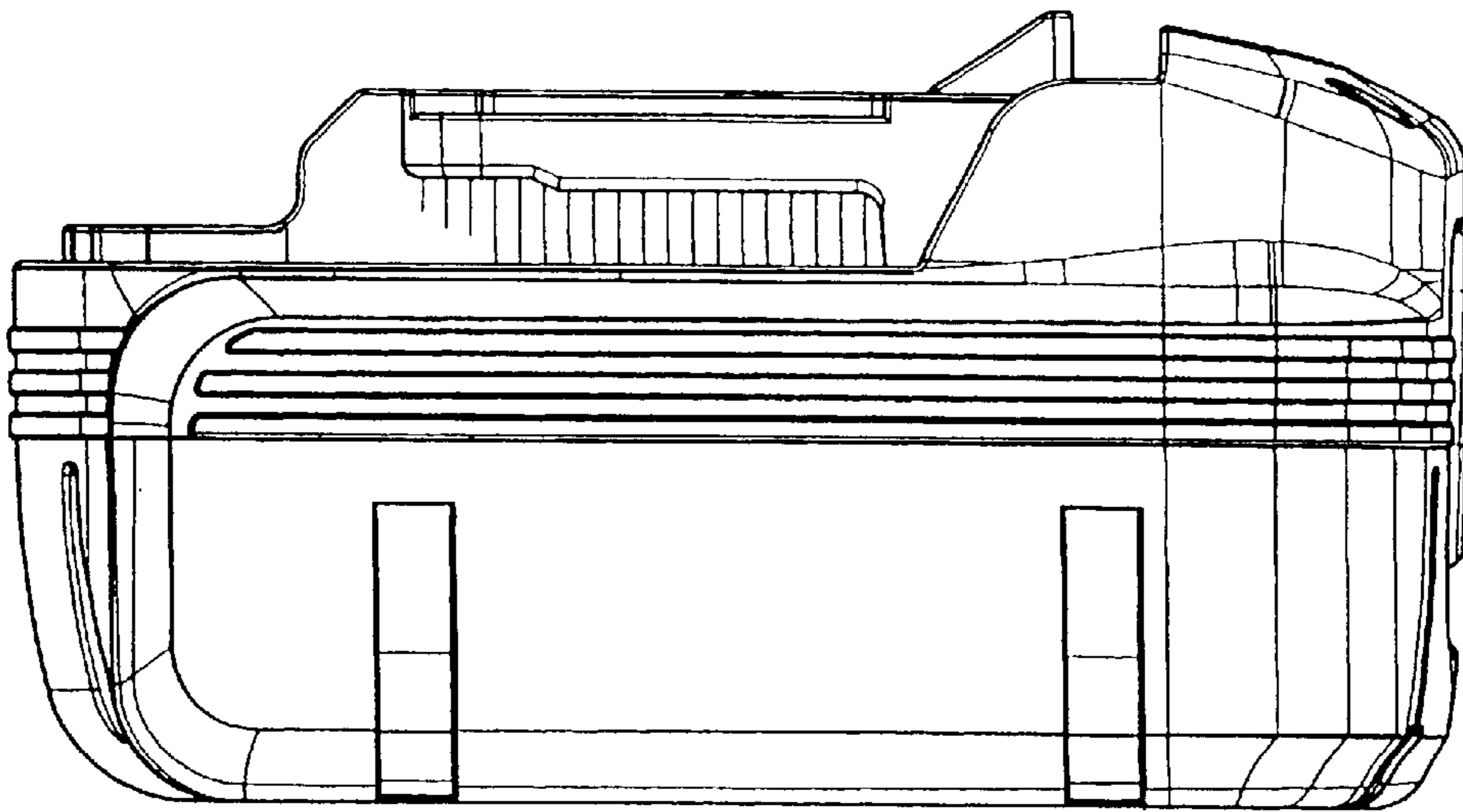

FIG. 3

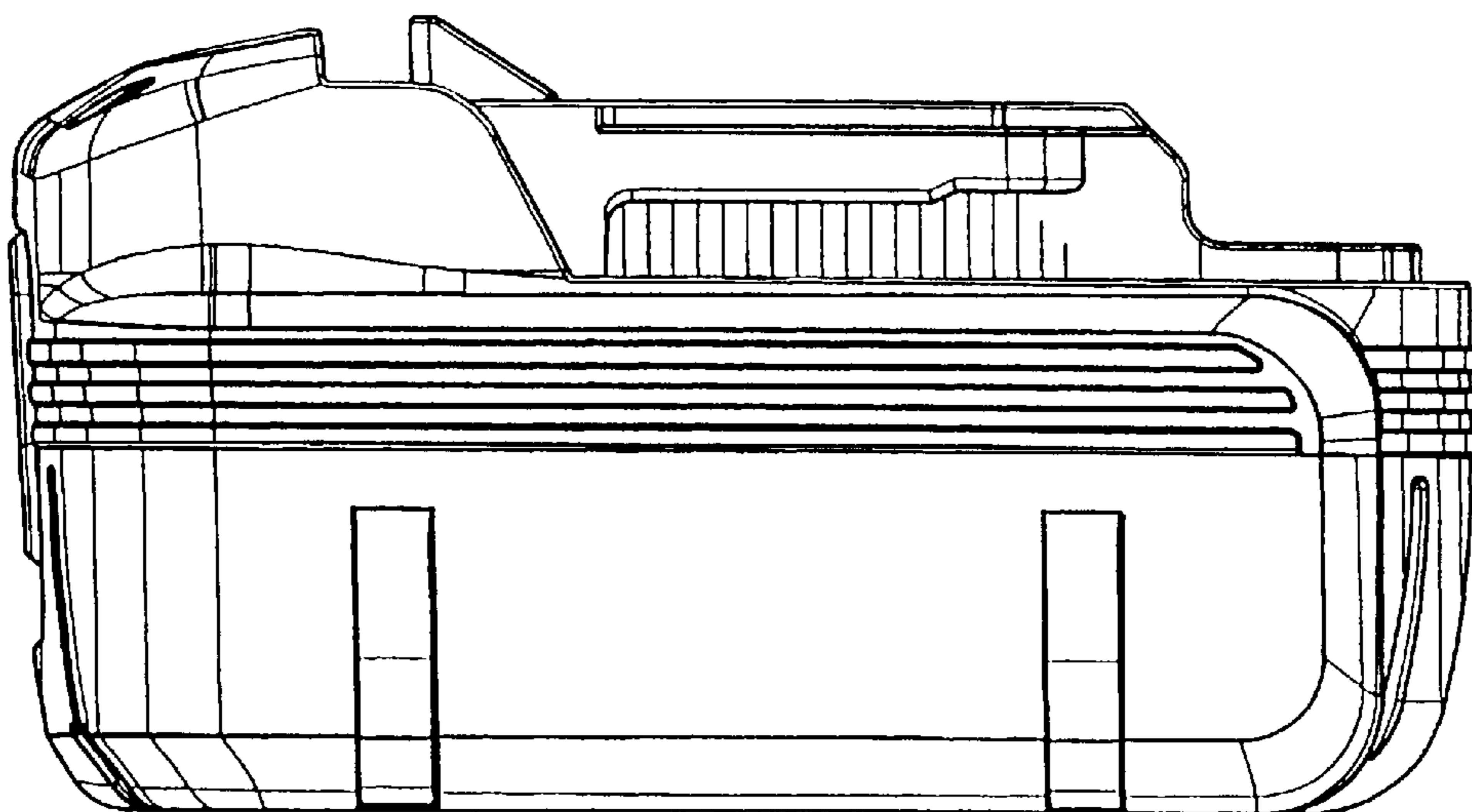

FIG. 4

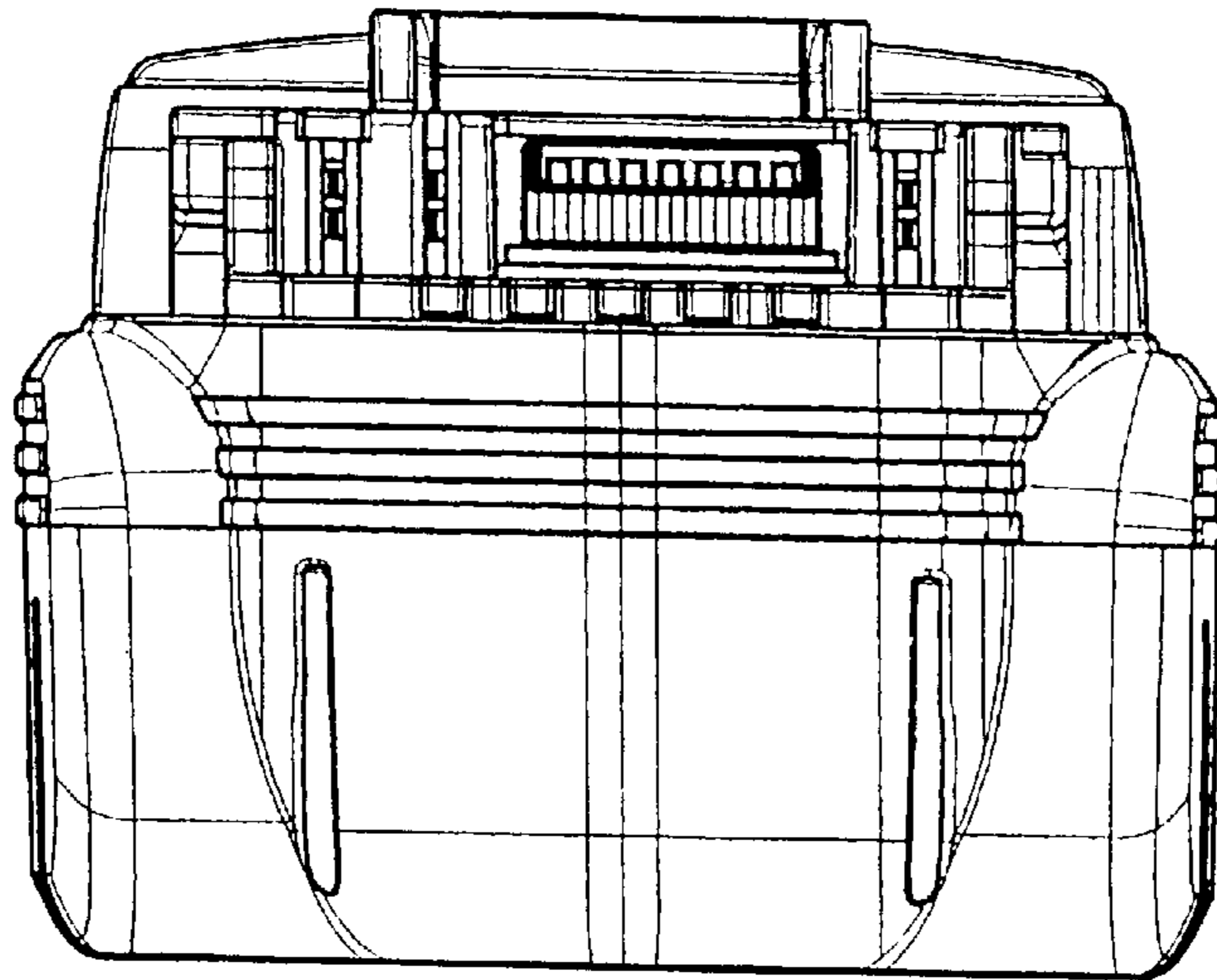

FIG. 5

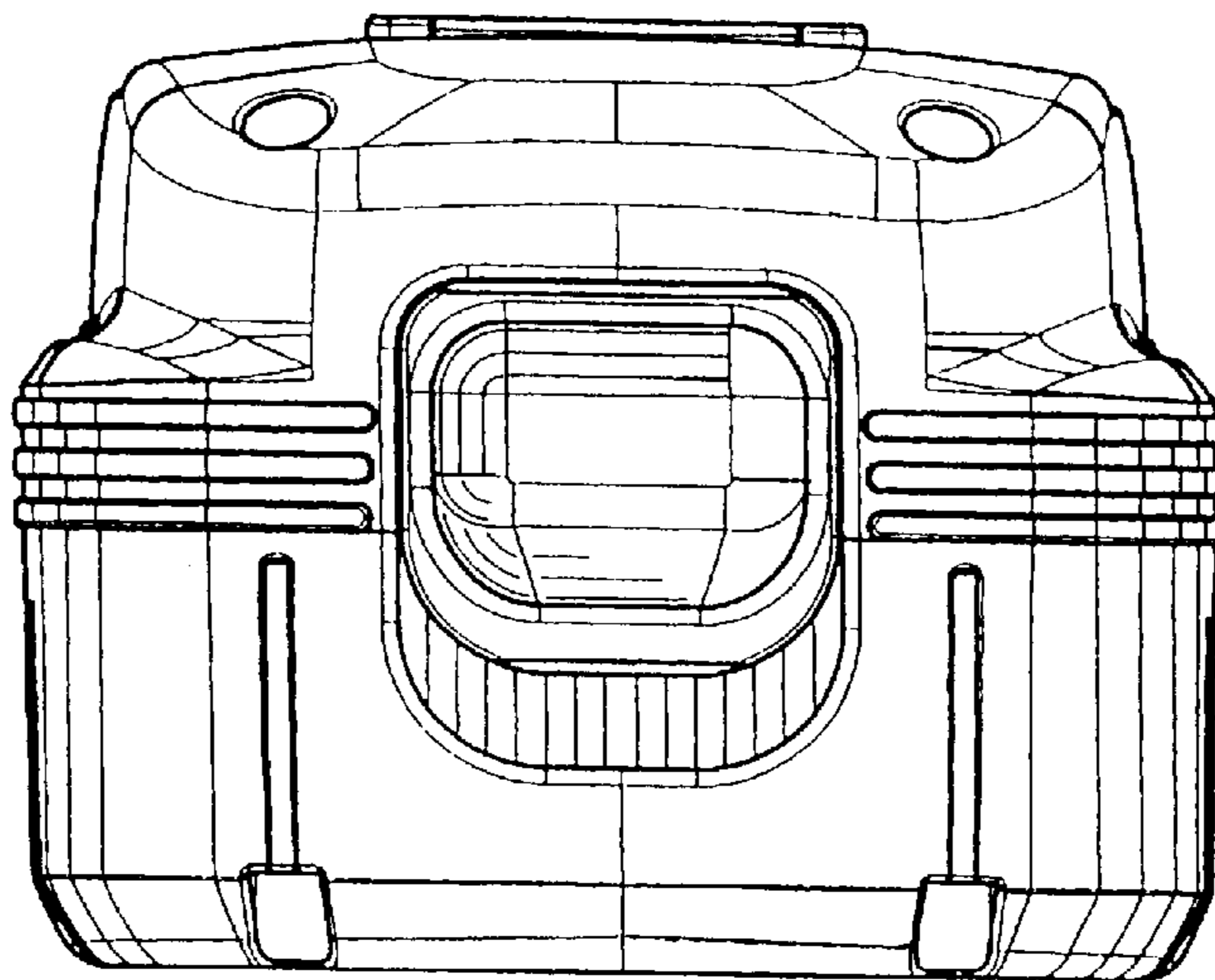

FIG. 6

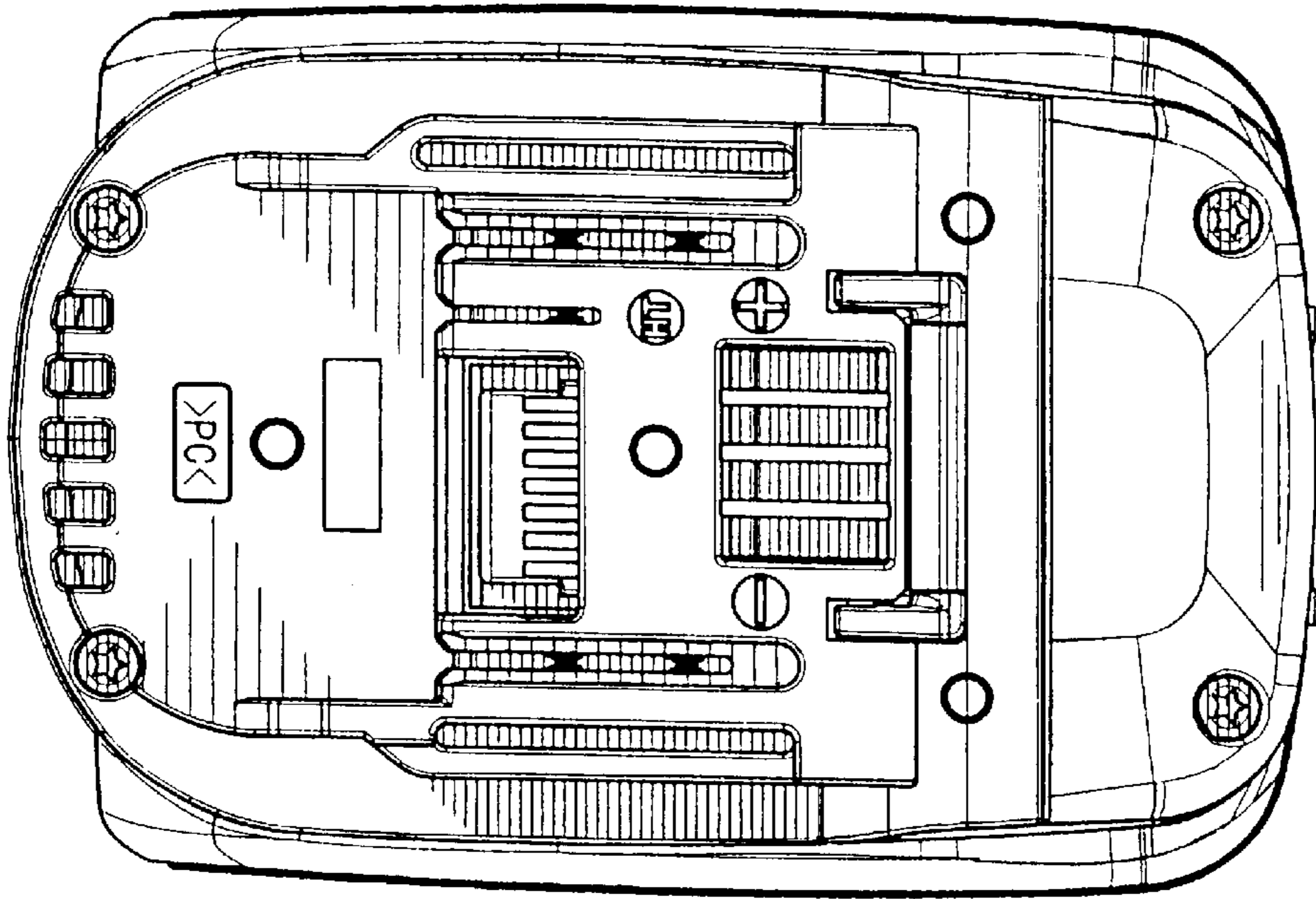

FIG. 7

