



US00D481656S

(12) **United States Design Patent**
Fukushima

(10) **Patent No.:** **US D481,656 S**

(45) **Date of Patent:** **** Nov. 4, 2003**

(54) **AUTOMOBILE**

(75) Inventor: **Yusuke Fukushima**, Tokyo (JP)

(73) Assignee: **Toyota Jidosha Kabushiki Kaisha (JP)**

(**) Term: **14 Years**

(21) Appl. No.: **29/173,055**

(22) Filed: **Dec. 20, 2002**

(51) **LOC (7) Cl.** **12-08**

(52) **U.S. Cl.** **D12/98**

(58) **Field of Search** D12/98, 93; 296/183,
296/185, 186

(56) **References Cited**

U.S. PATENT DOCUMENTS

- D369,991 S * 5/1996 Hunter et al. D12/98
- D372,211 S * 7/1996 Hunter et al. D12/98
- D419,920 S * 2/2000 Kondo et al. D12/98

OTHER PUBLICATIONS

2002 Toyota Tundra, Brochure of Toyota: Get The Feeling.,
2001, p. 41.

2002 Toyota Sequoia, Brochure of Toyota: Get The Feeling.,
2001, p. 29.

* cited by examiner

Primary Examiner—Melody N. Brown

(74) *Attorney, Agent, or Firm*—SAIDMAN DesignLaw
Group

(57) **CLAIM**

The ornamental design for an automobile, as shown and
described.

DESCRIPTION

FIG. 1 is a front and side perspective view of an automobile
showing my new design;

FIG. 2 is a side and rear perspective view thereof;

FIG. 3 is a front view thereof;

FIG. 4 is a rear view thereof;

FIG. 5 is a right side view thereof; the left side view being
a mirror image; and,

FIG. 6 is a top view thereof.

1 Claim, 2 Drawing Sheets





FIG. 1



FIG. 2

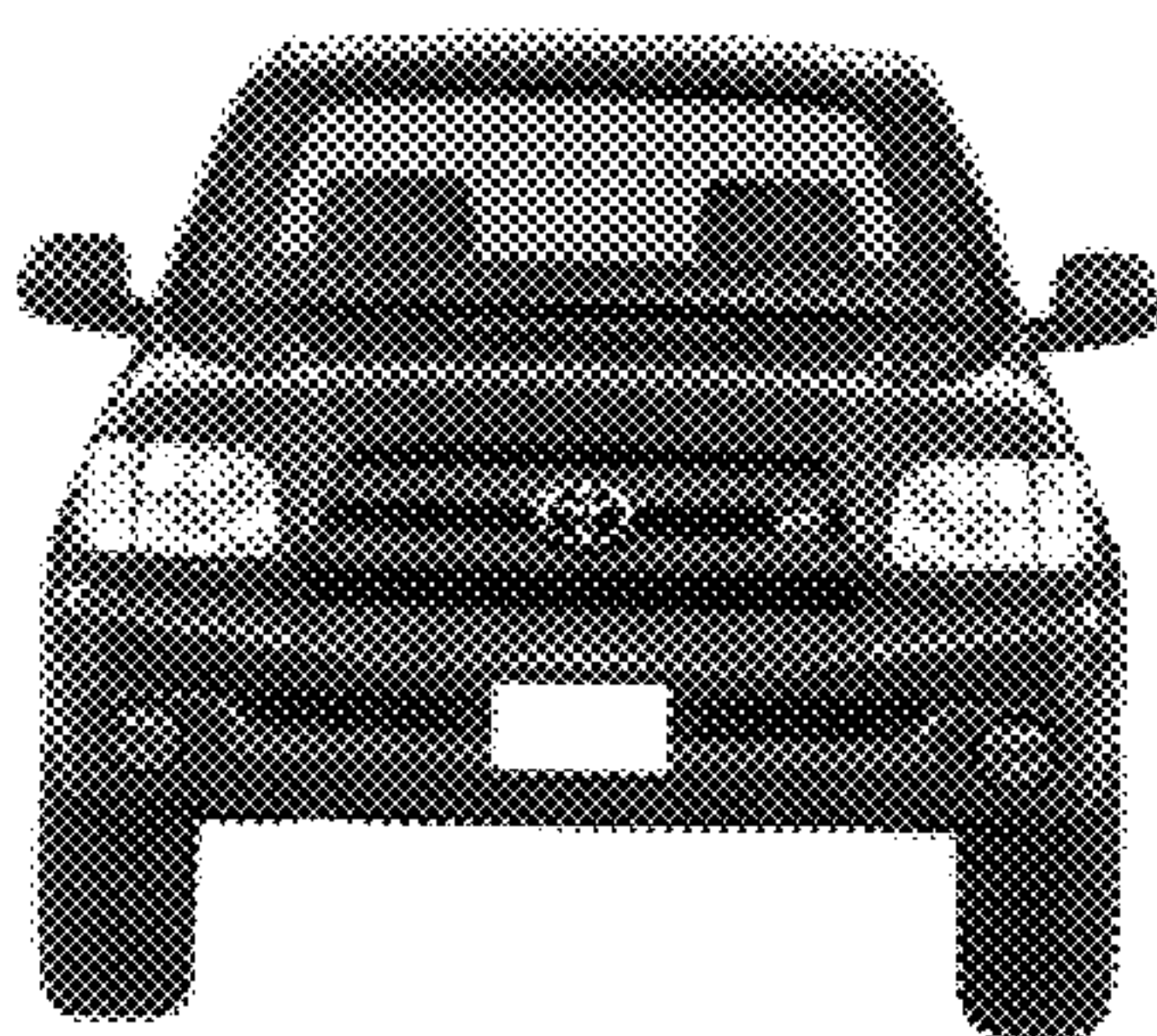

FIG. 3

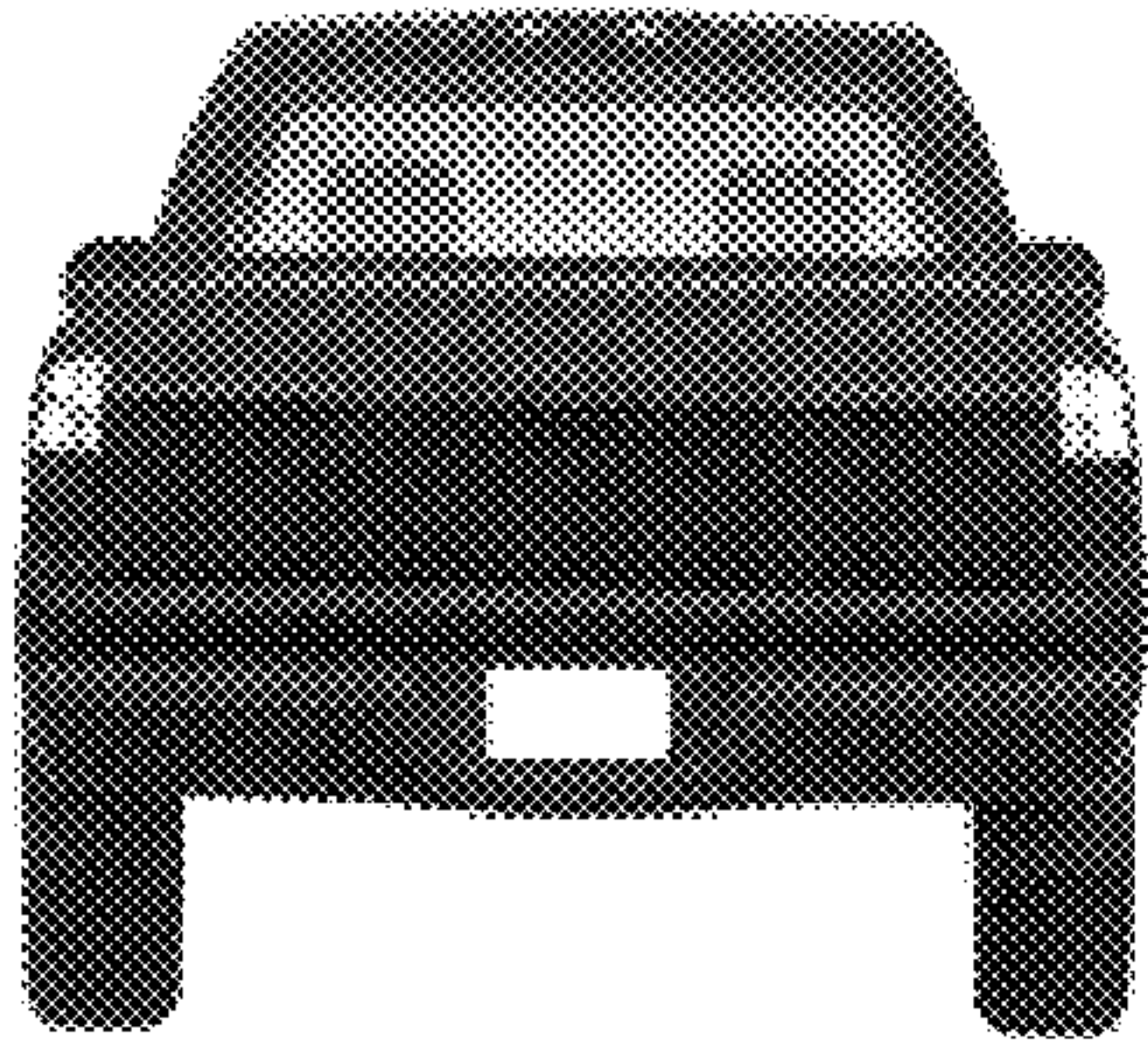

FIG. 4

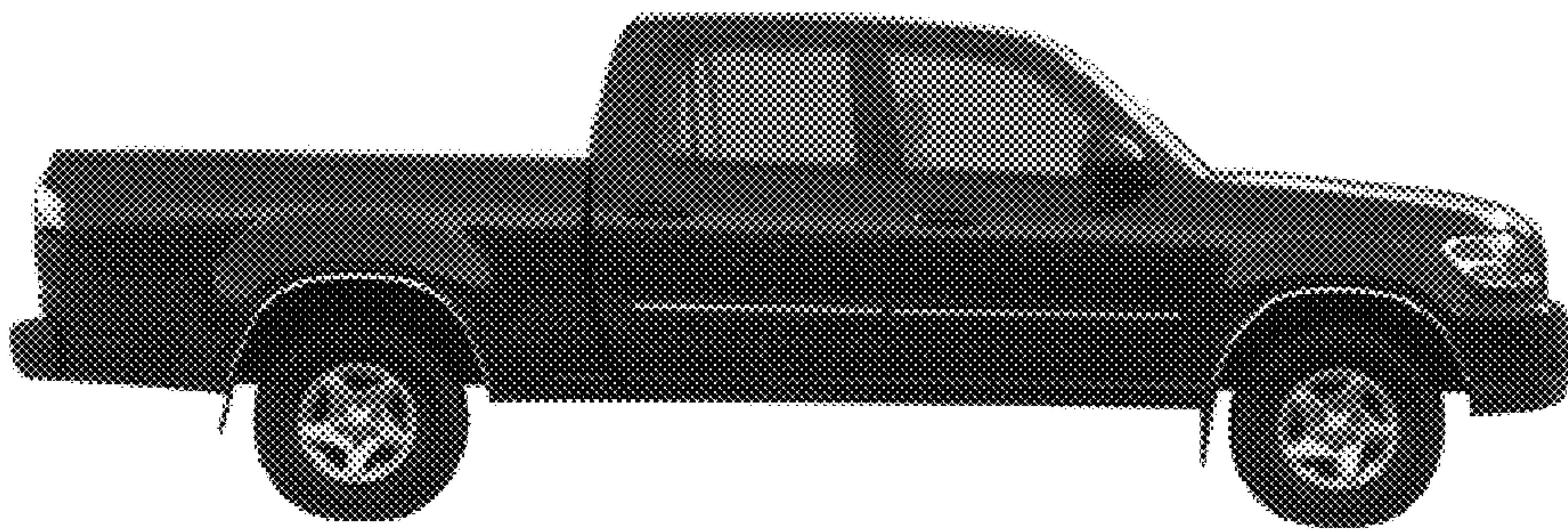

FIG. 5

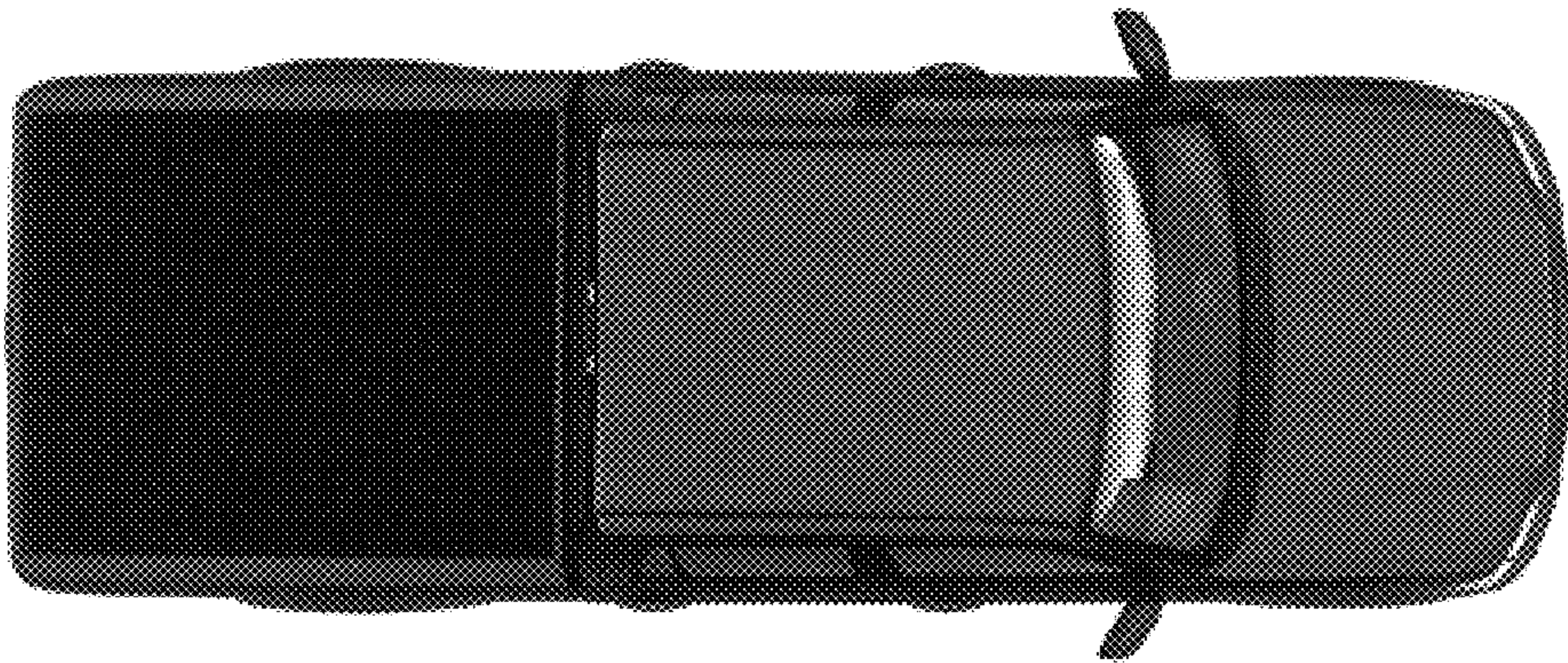

FIG. 6