



US00D481464S

(12) **United States Design Patent**
Michaels

(10) **Patent No.:** **US D481,464 S**

(45) **Date of Patent:** **** Oct. 28, 2003**

(54) **BUILDING**

(76) Inventor: **David Michaels**, 1350 E. Flamingo Rd.
#432, Las Vegas, NV (US) 89119

(**) Term: **14 Years**

(21) Appl. No.: **29/165,788**

(22) Filed: **Aug. 16, 2002**

(51) **LOC (7) Cl.** **25-03**

(52) **U.S. Cl.** **D25/10; D25/7; D25/33**

(58) **Field of Search** **D25/4, 7, 10, 33**

(56) **References Cited**

U.S. PATENT DOCUMENTS

D220,382 S	*	4/1971	Cooper	D25/10
D283,622 S	*	4/1986	Crosby et al.	D25/10
D291,356 S	*	8/1987	Sapicha	D25/10

* cited by examiner

Primary Examiner—Doris Clark

(74) *Attorney, Agent, or Firm*—Anderson & Morishita;
Robert Ryan Morishita

(57) **CLAIM**

The ornamental design for a building, as shown and described.

DESCRIPTION

FIG. 1 is a front elevated perspective view of a building according to the present invention;

FIG. 2 is a top view of the building of FIG. 1;

FIG. 3 is a left side view of the building of FIG. 1;

FIG. 4 is a front view of the building of FIG. 1;

FIG. 5 is a right side view of the building of FIG. 1; and,

FIG. 6 is a rear view of the building of FIG. 1.

The broken lines are for illustrative purposes only, and form no part of the claimed design.

1 Claim, 6 Drawing Sheets

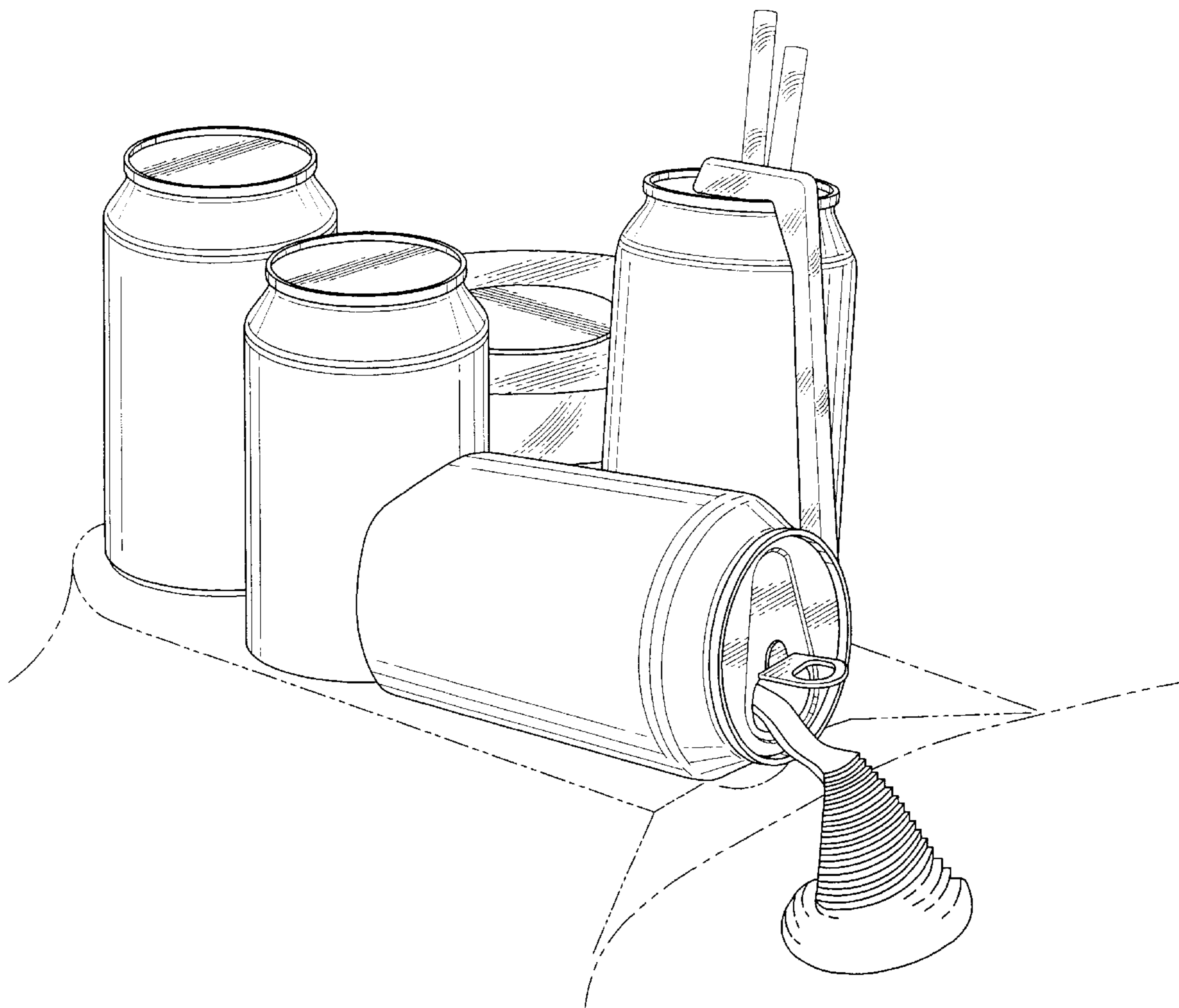

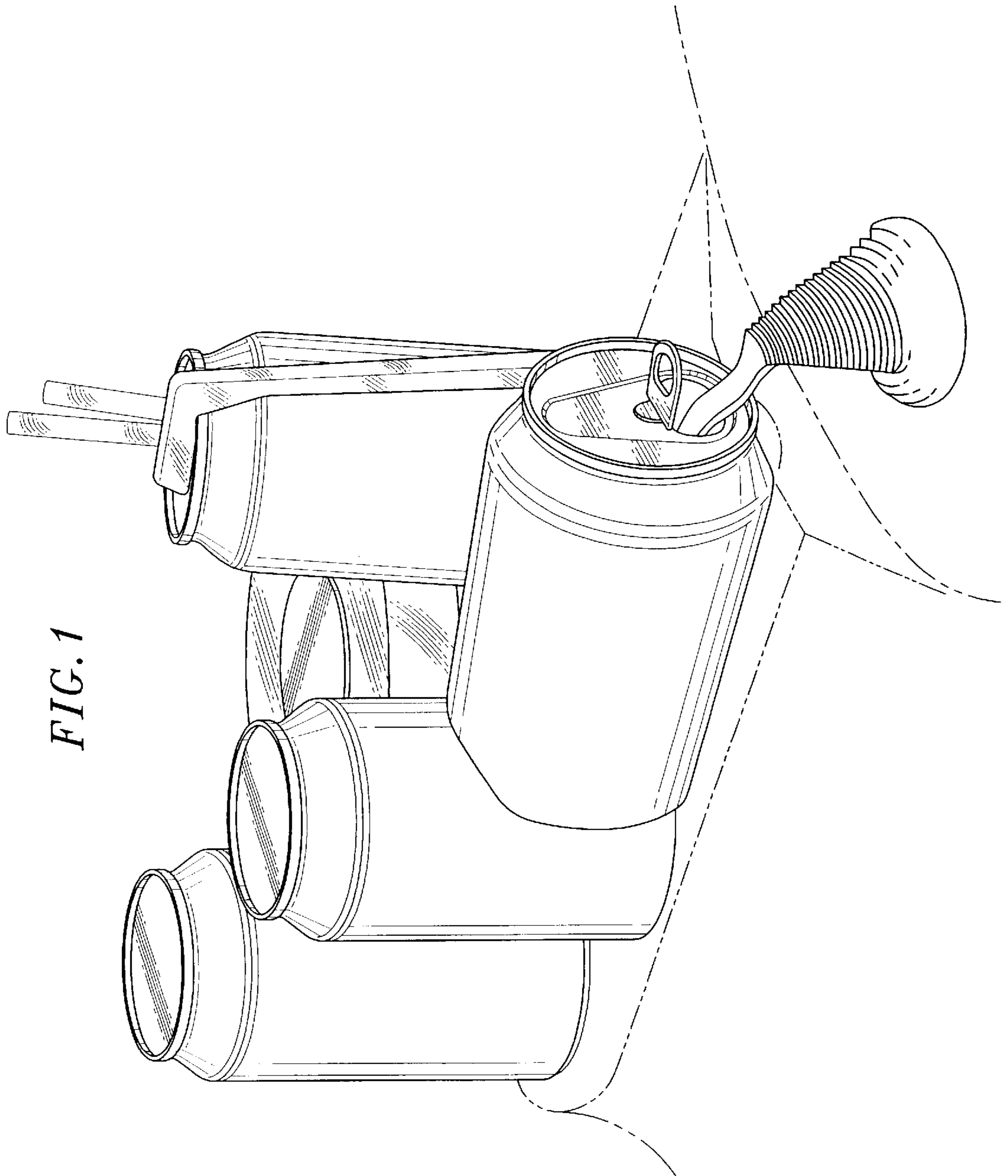

FIG. 1

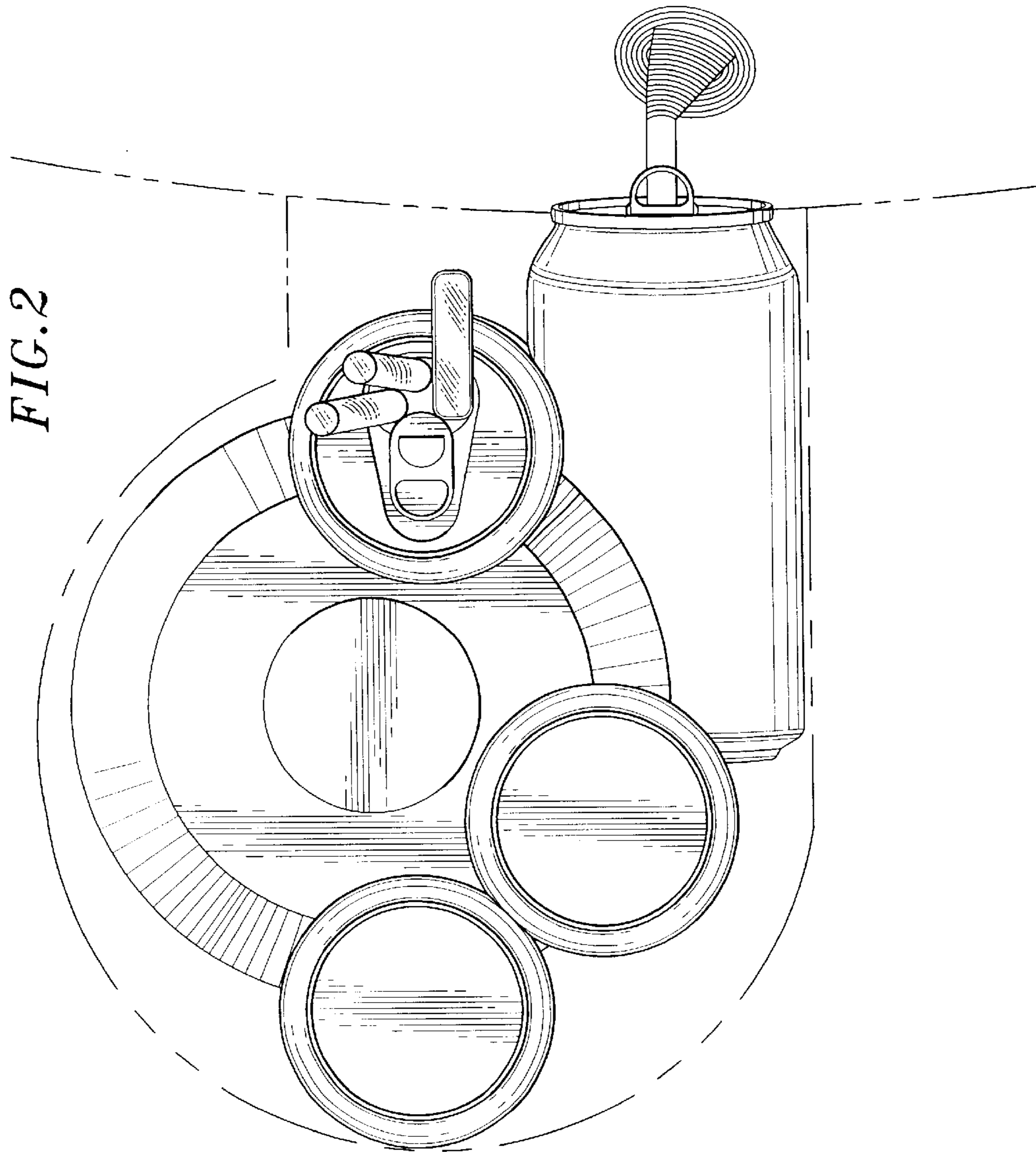

FIG. 3

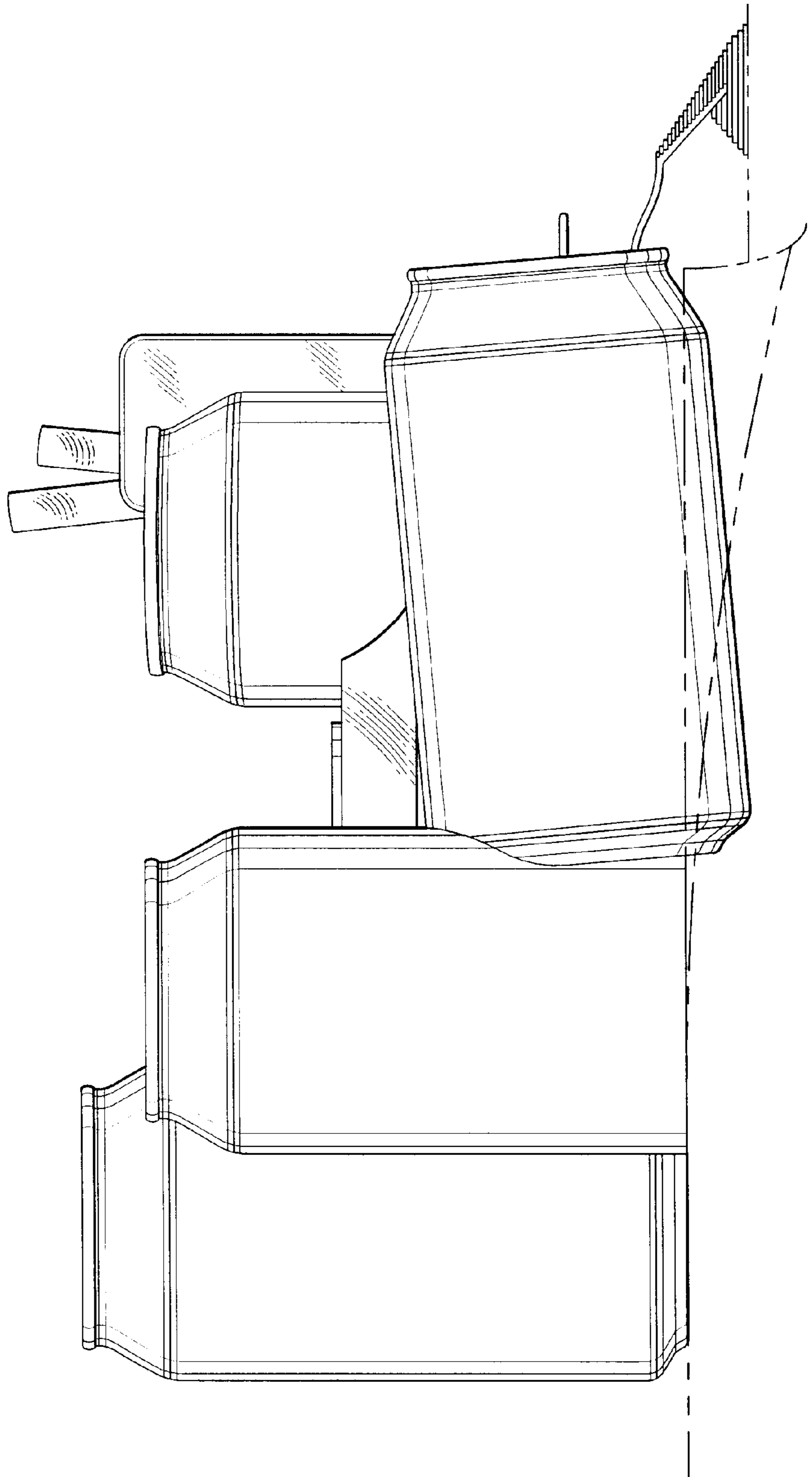

FIG. 4

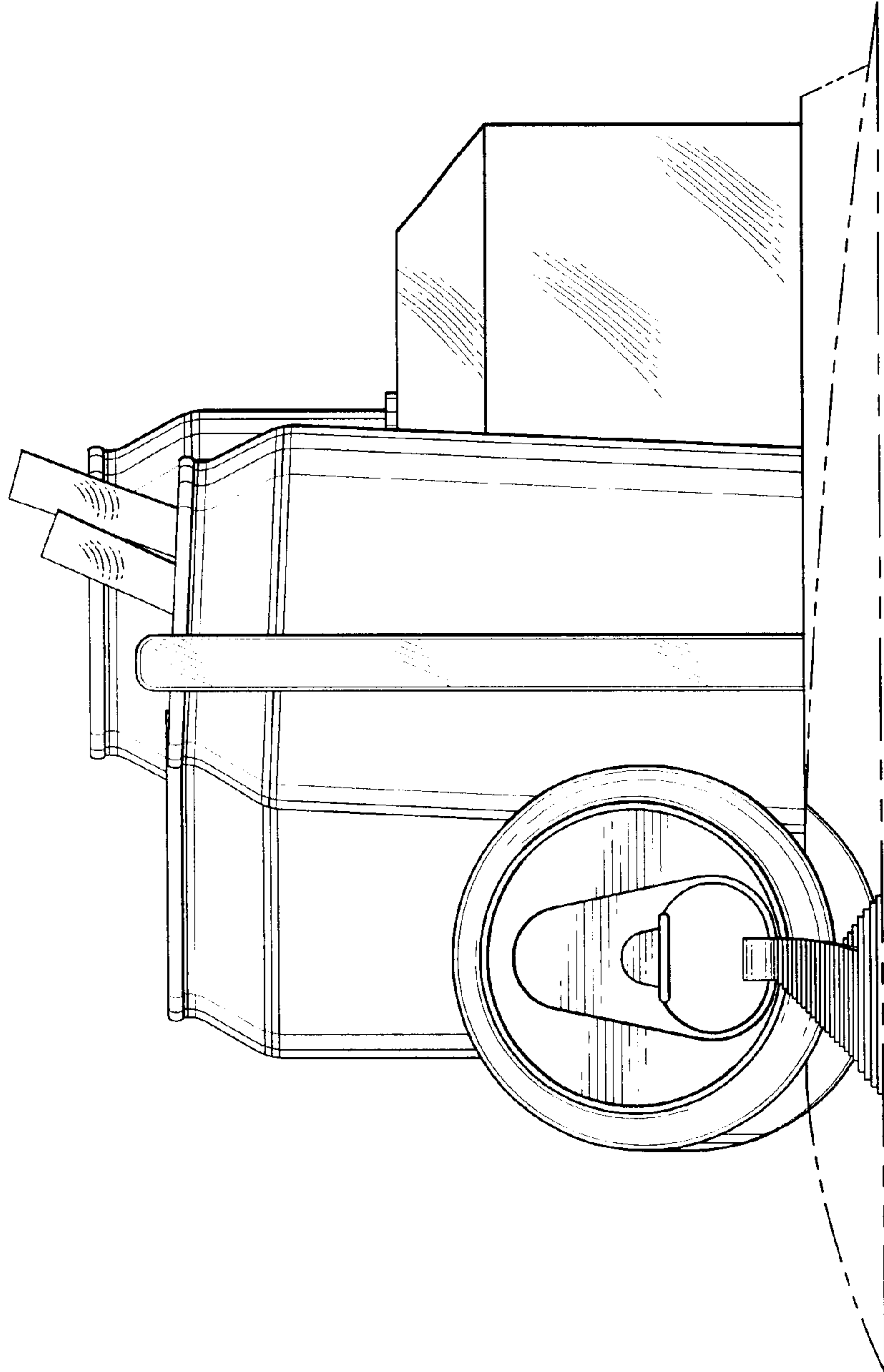

FIG. 5

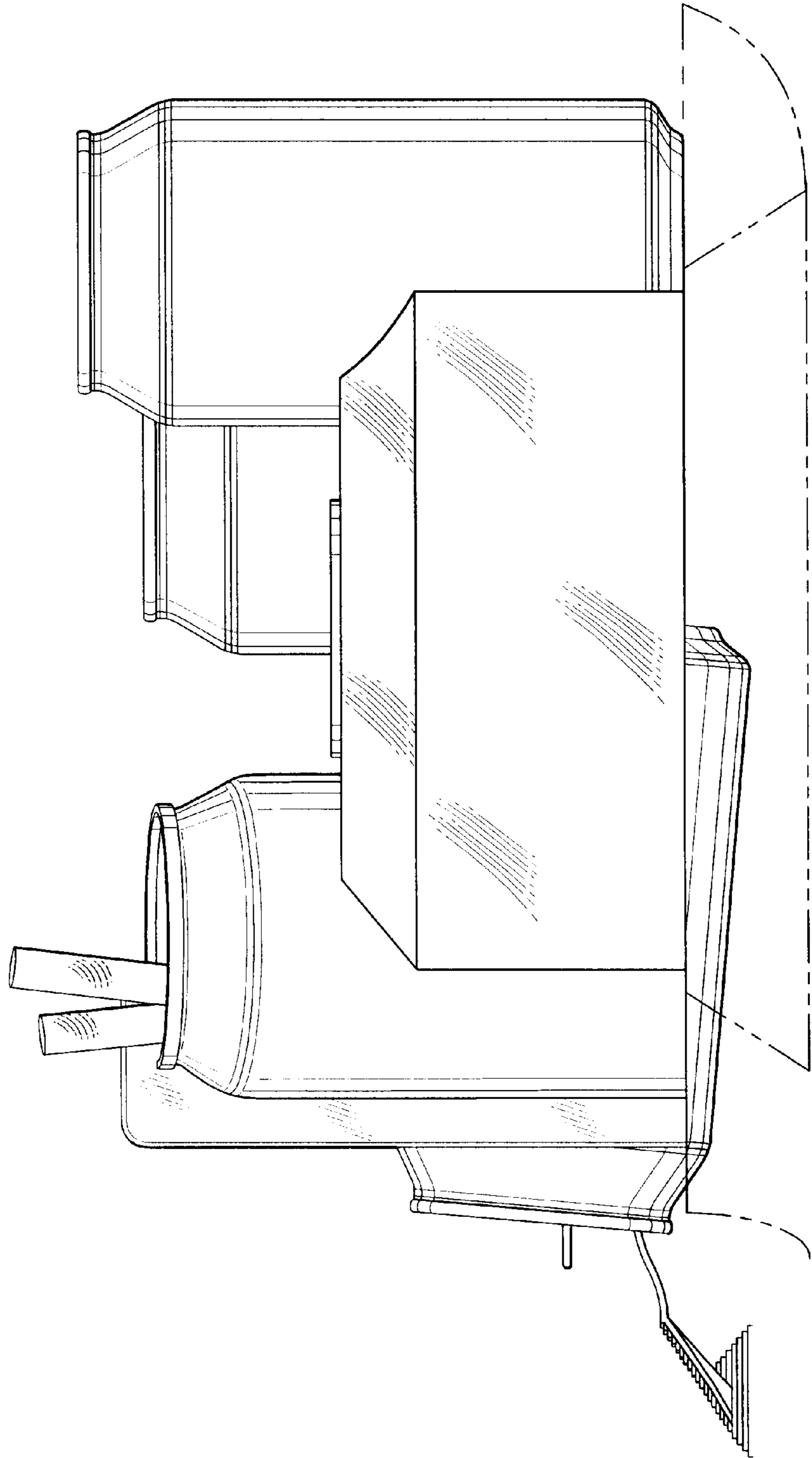

FIG. 6

