



US00D481229S

(12) **United States Design Patent** (10) **Patent No.:** **US D481,229 S**
Weaver (45) **Date of Patent:** **** Oct. 28, 2003**

(54) **OTTOMAN**

(75) Inventor: **Paul J. Weaver**, San Francisco, CA (US)

(73) Assignee: **Michael Taylor Designs, Inc.**, San Francisco, CA (US)

(**) Term: **14 Years**

(21) Appl. No.: **29/176,307**

(22) Filed: **Feb. 20, 2003**

(51) **LOC (7) Cl.** **06-01**

(52) **U.S. Cl.** **D6/499; D6/495; D6/484; D6/349**

(58) **Field of Search** **D6/349-353, 355, D6/484, 495, 499; 297/461, 462, 423.1, 423.39, 423.41; 248/188, 188.1, 188.8**

(56) **References Cited**

U.S. PATENT DOCUMENTS

3,883,104 A	*	5/1975	Delafield	248/188
D243,215 S	*	2/1977	Winrow	D6/352
D249,312 S	*	9/1978	Taber	D6/484
D455,300 S	*	4/2002	Davies et al.	D6/484

OTHER PUBLICATIONS

Architectural Digest, "La Quinta Norte—Douglas S. Cramer's Ranch in Santa Ynez Valley", pp. 137-147, May 1985.
Weaver, pending U.S. design patent application Ser. No. 29/176,361, filed Feb. 20, 2003, entitled "Lounge Chair".

Weaver, pending U.S. design patent application Ser. No. 29/176,305, filed Feb. 20, 2003, entitled "Chaise".

Weaver, pending U.S. design patent application Ser. No. 29/176,359, filed Feb. 20, 2003, entitled "Chaise".

Weaver, pending U.S. design patent application Ser. No. 29/176,303, filed Feb. 20, 2003, entitled "Dining Chair".

Weaver, pending U.S. design patent application Ser. No. 29/176,300, filed Feb. 20, 2003, entitled "Platform".

* cited by examiner

Primary Examiner—Janice E. Seeger

(74) *Attorney, Agent, or Firm*—Heslin Rothenberg Farley & Mesiti P.C.

(57) **CLAIM**

The ornamental design for the ottoman, as shown and described.

DESCRIPTION

FIG. 1 is a perspective view of an ottoman in accordance with the new design;

FIG. 2 is a top view thereof;

FIG. 3 is a front elevational view thereof;

FIG. 4 is a left side elevational view thereof, a right side elevational view being a mirror image thereof;

FIG. 5 is a rear elevational view thereof; and,

FIG. 6 is a perspective view of an alternative embodiment of an ottoman in accordance with the new design, a portion of which is cut away to illustrate indeterminate length.

The broken lines in FIGS. 1 and 6 are for illustrative purposes only and form no part of the claimed design.

1 Claim, 4 Drawing Sheets

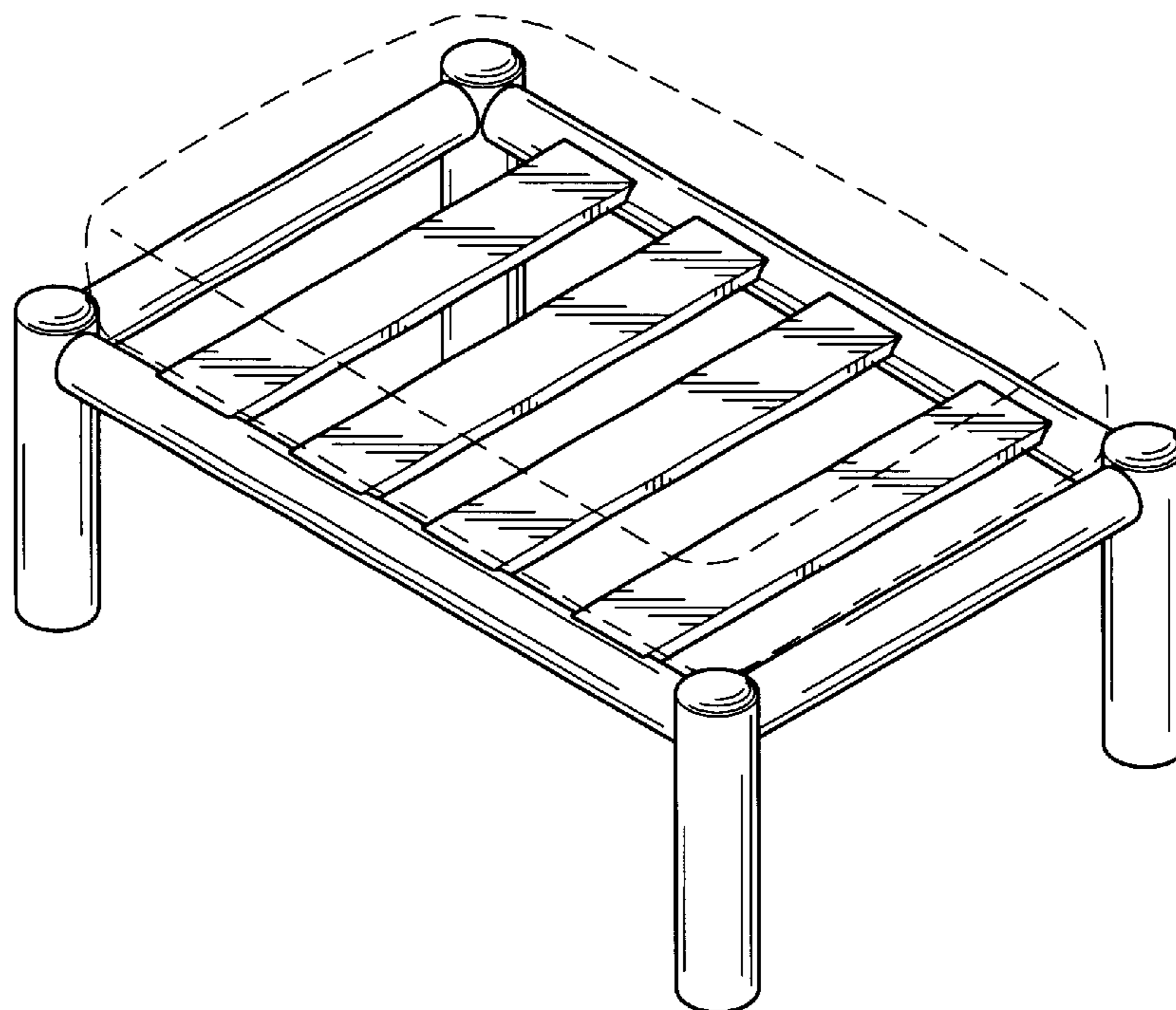

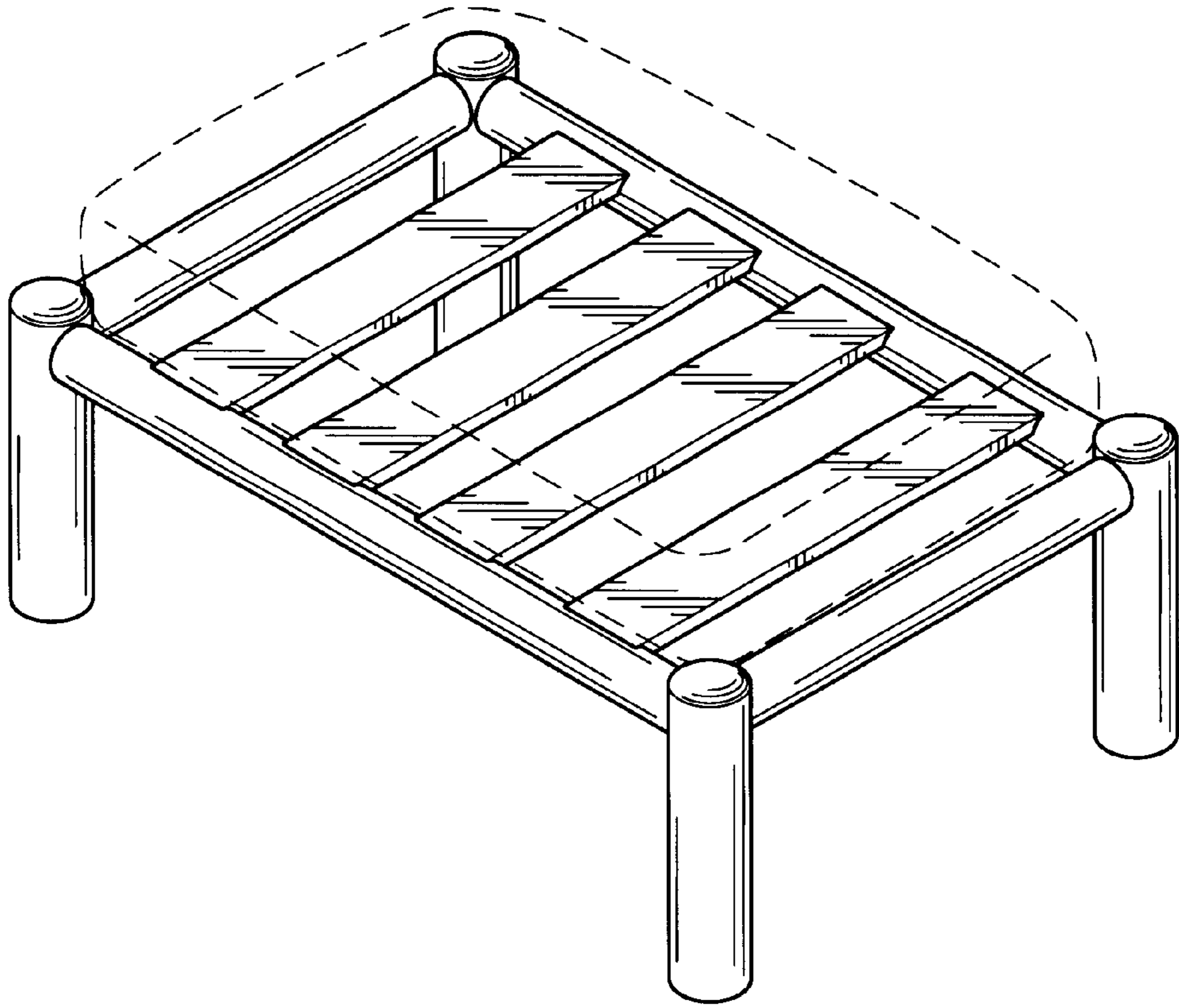

FIG. 1

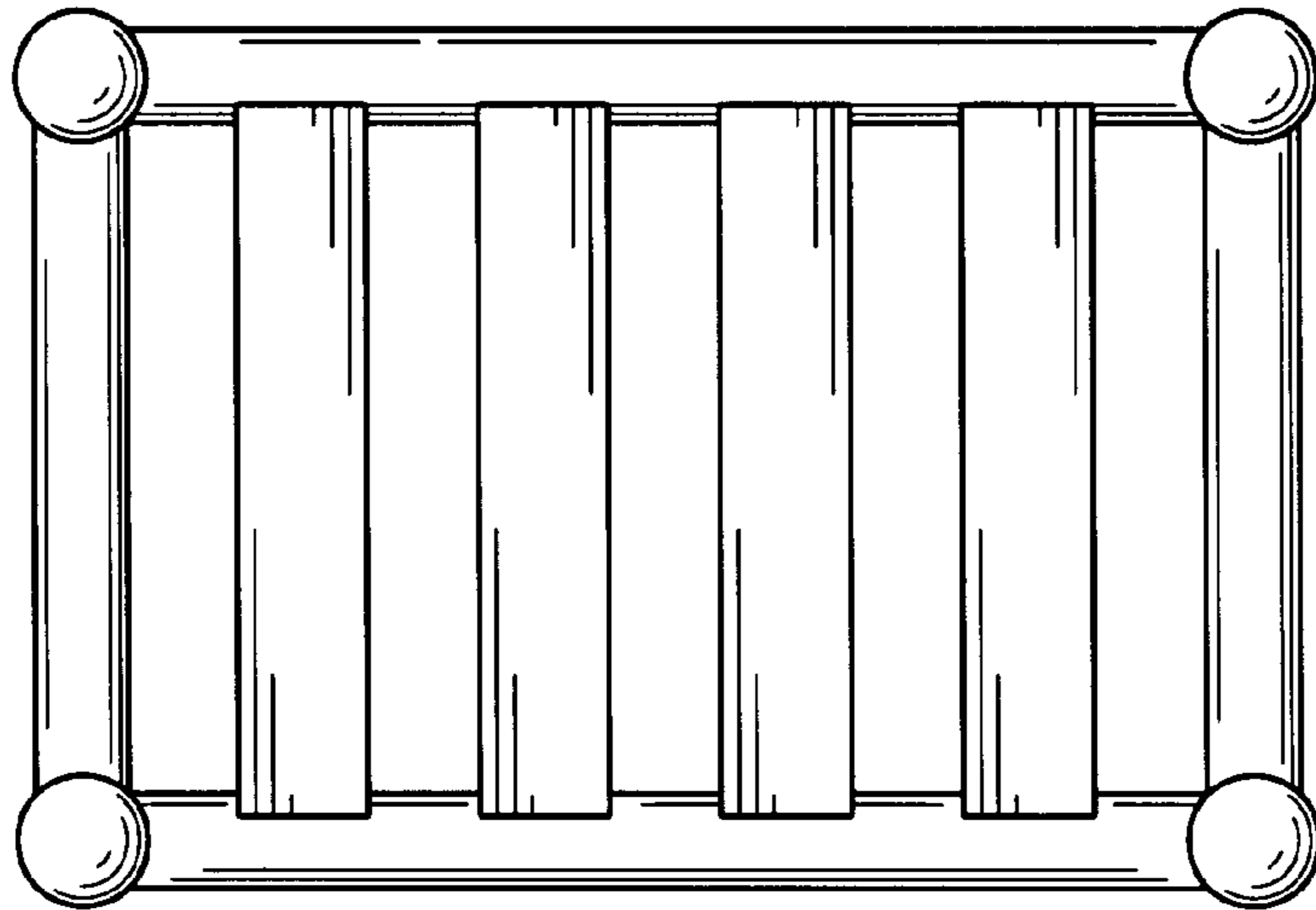

FIG. 2

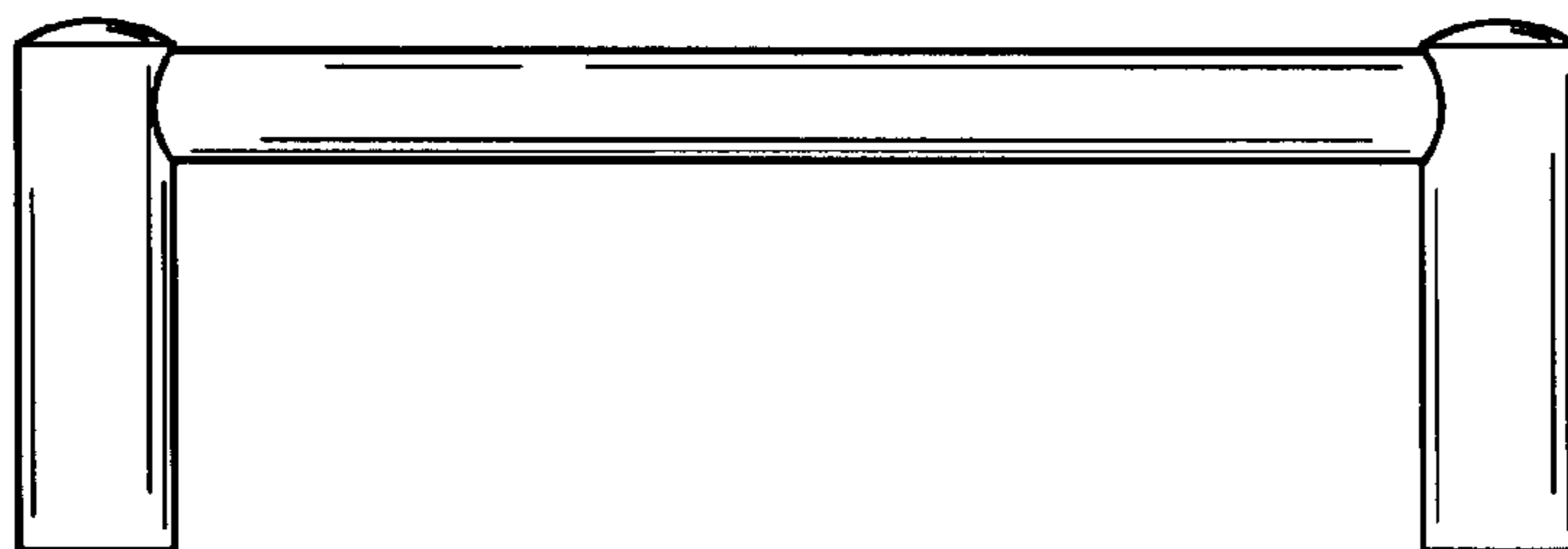

FIG. 3

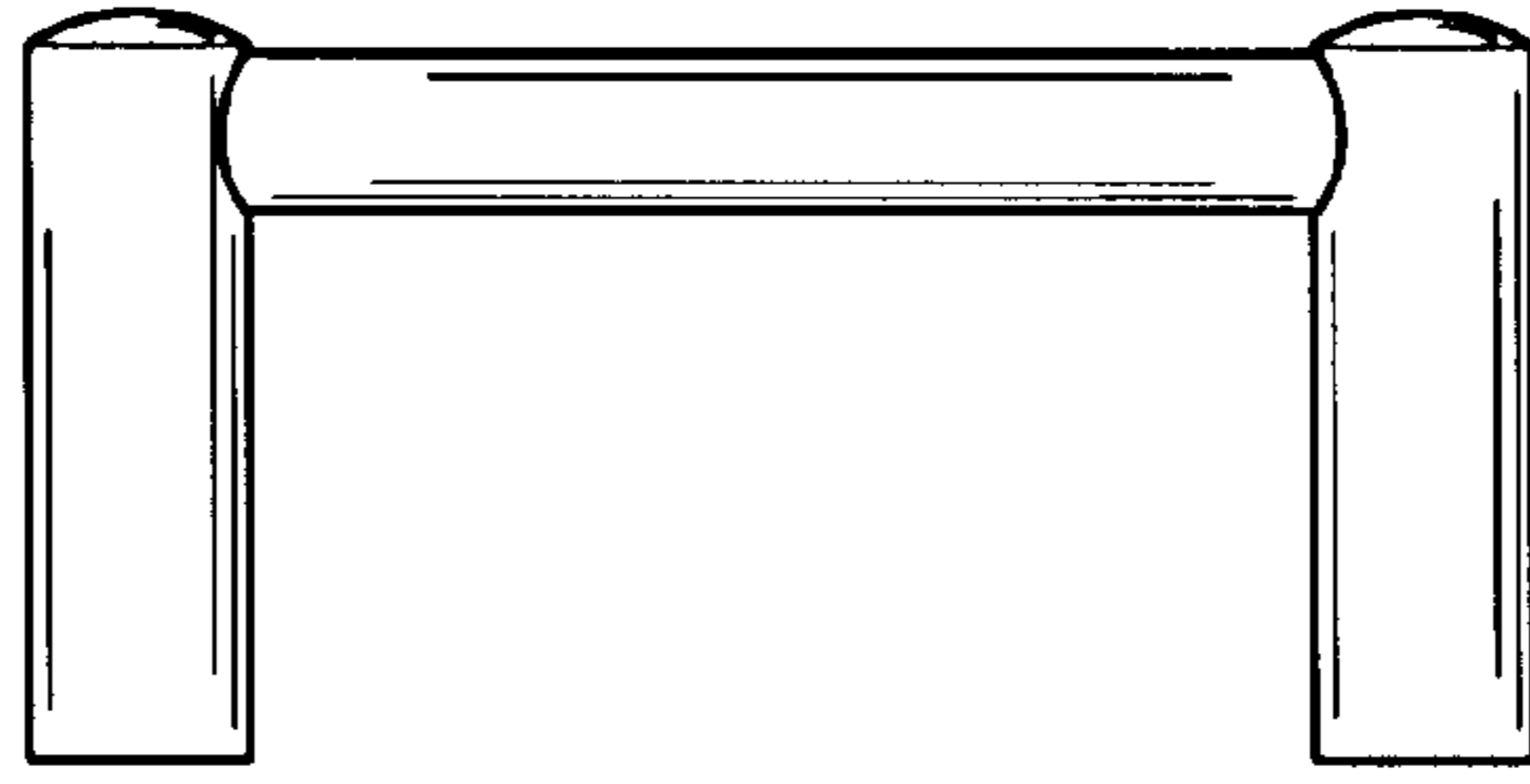

FIG. 4

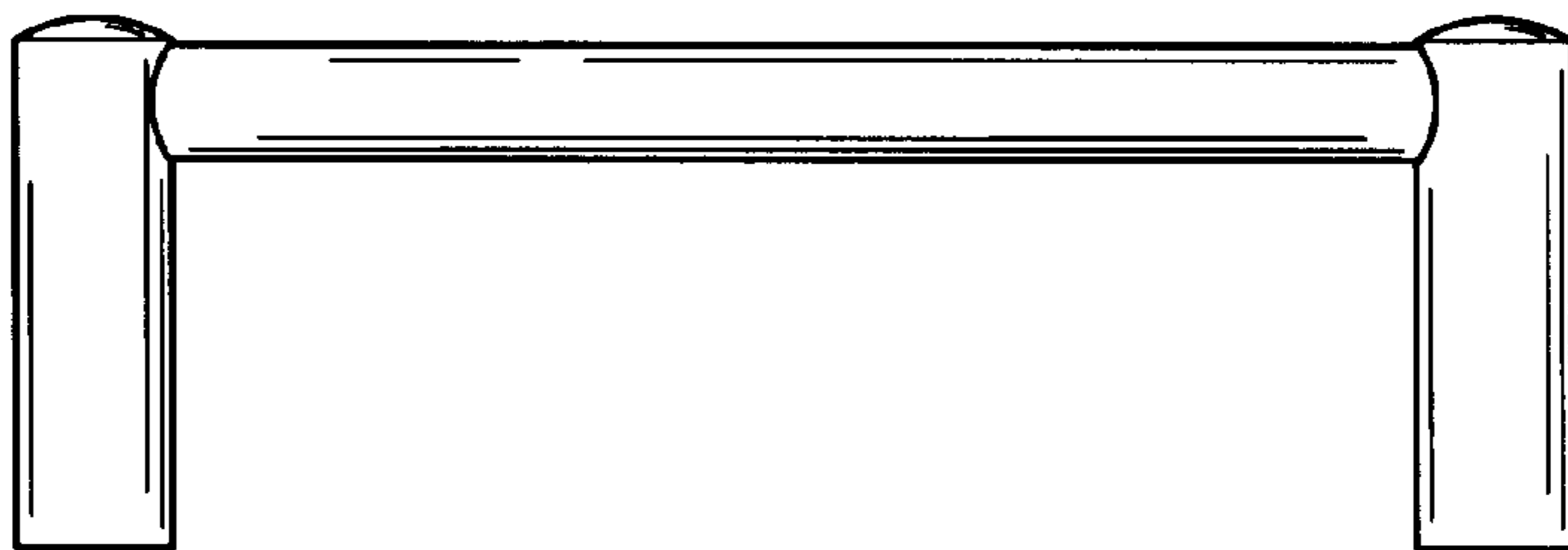

FIG. 5

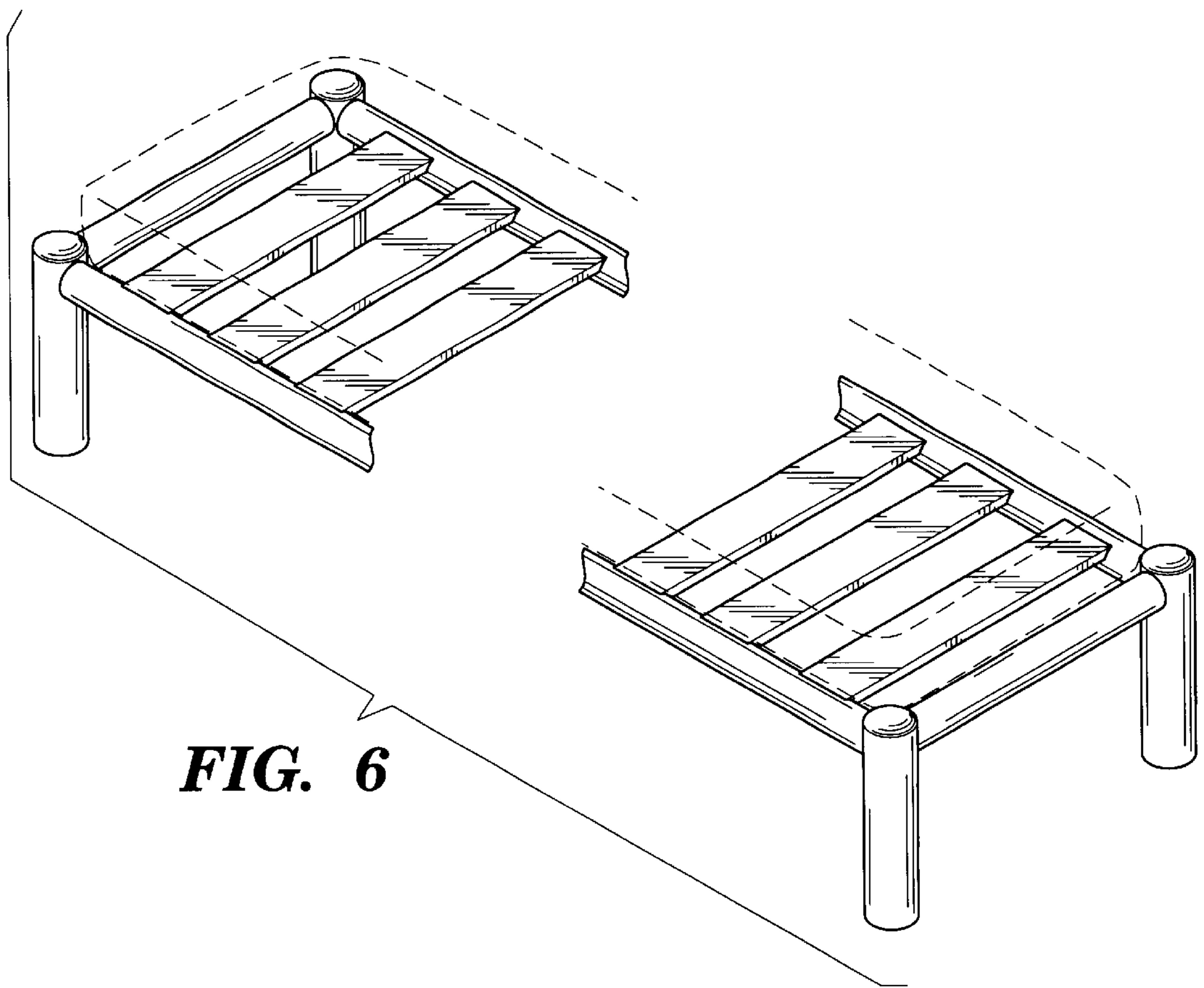

FIG. 6