



US00D481223S

(12) **United States Design Patent** (10) **Patent No.:** **US D481,223 S**  
**Locker et al.** (45) **Date of Patent:** **\*\* Oct. 28, 2003**

(54) **MODEL DISPLAY CASE**

(76) Inventors: **Billy Locker**, 344 Lees Creek Rd., Fayetteville, TN (US) 37334; **Steve Branch**, 119 Simmons Cir., Fayetteville, TN (US) 37334

(\*\*) Term: **14 Years**

(21) Appl. No.: **29/167,615**

(22) Filed: **Sep. 18, 2002**

(51) **LOC (7) Cl.** ..... **06-04**

(52) **U.S. Cl.** ..... **D6/470**

(58) **Field of Search** ..... D6/450, 470, 471, D6/472; D9/414, 418, 501; D11/131, 133, 138

(56) **References Cited**

**U.S. PATENT DOCUMENTS**

D168,686 S	*	1/1953	Hunter	.....	D6/450
D242,406 S	*	11/1976	Romanoff	.....	D6/559
D402,586 S	*	12/1998	Johnson et al.	.....	D11/131
D431,187 S	*	9/2000	Davis	.....	D9/331
D431,734 S		10/2000	Edgell		
D447,363 S		9/2001	Tharpe		

**OTHER PUBLICATIONS**

Chevrolet Advertisement, Car and Driver, p. 52, Jul. 2000.\*

\* cited by examiner

*Primary Examiner*—Cathron C. Brooks

(74) *Attorney, Agent, or Firm*—Lanier Ford Shaver & Payne P.C.

(57) **CLAIM**

We claim the ornamental design for a model display case, as shown and described.

**DESCRIPTION**

FIG. 1 is a left front perspective view of the model display case, showing my design.

FIG. 2 is a front elevational view thereof, the rear view being similar to the front view.

FIG. 3 is a top plan view thereof, the bottom view being similar to the top view.

FIG. 4 is a side elevational view thereof, both sides having a similar view.

FIG. 5 is a left front perspective view thereof, showing the model display case in an open position; and,

FIG. 6 is a left front perspective view of an alternate embodiment of the model display case, further showing a reflective mirror on the rearmost interior wall, the broken line showing of a model car being for illustrative purposes only and forming no part of the claimed design.

**1 Claim, 2 Drawing Sheets**

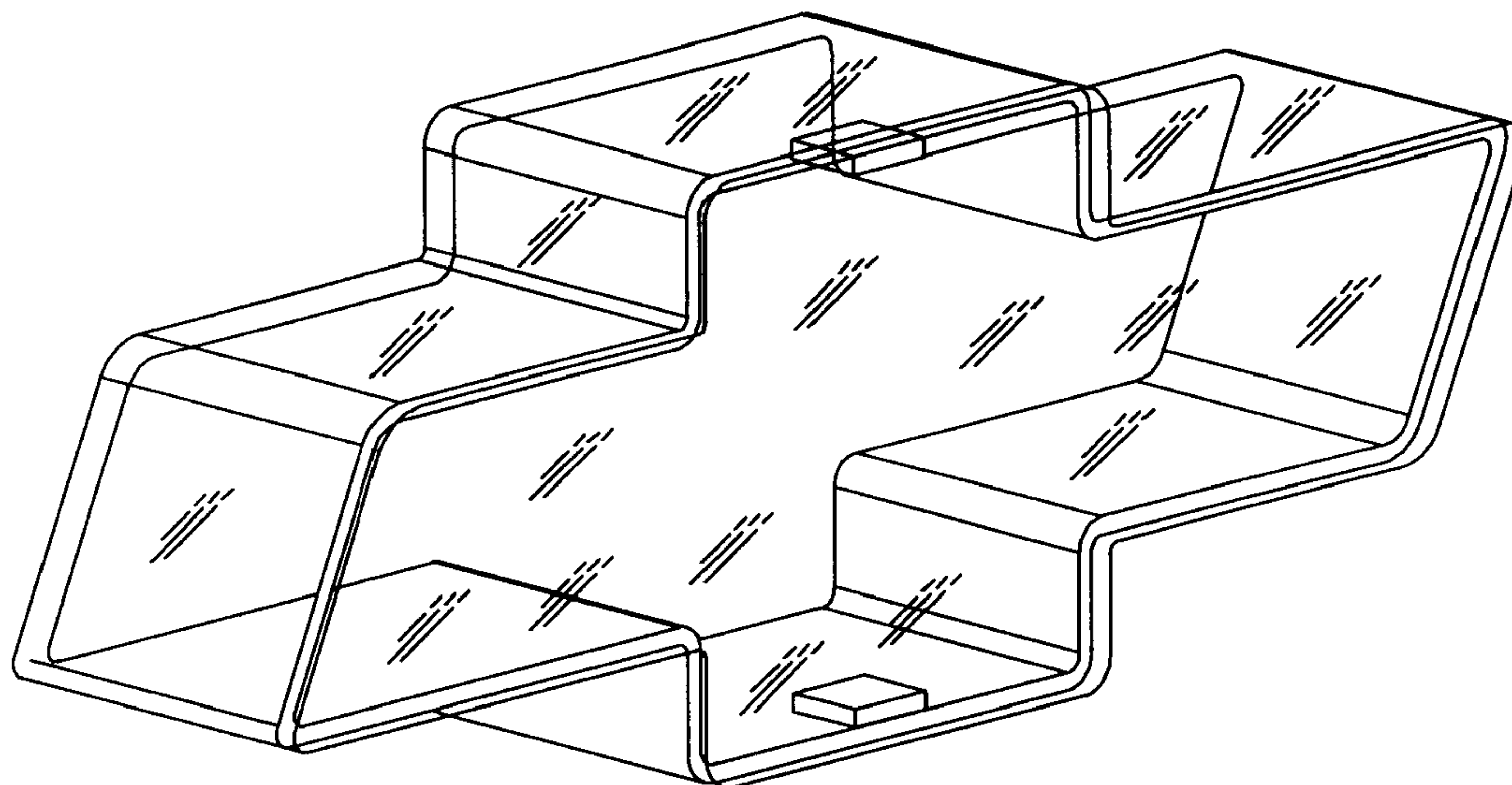

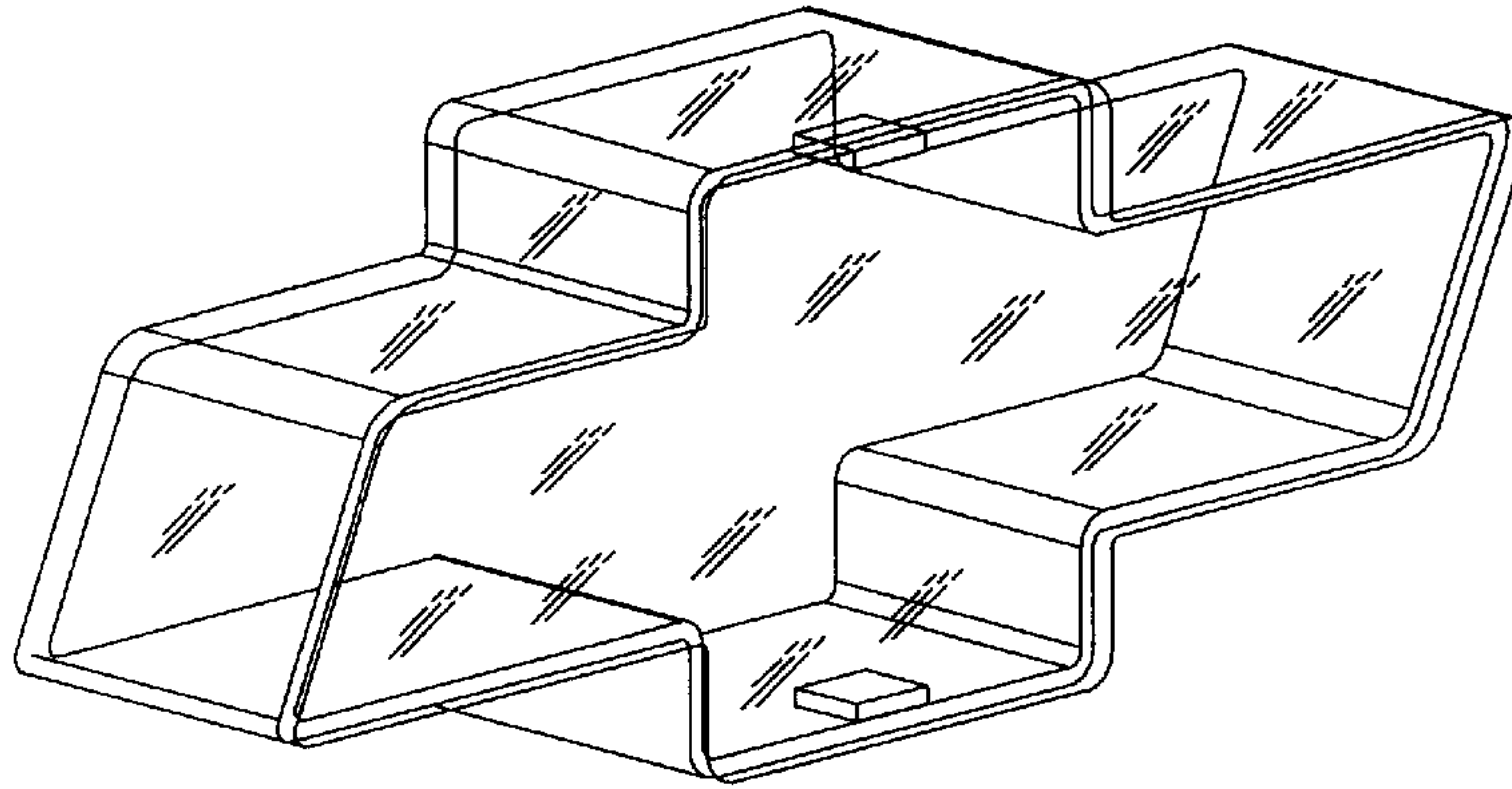

FIG. 1

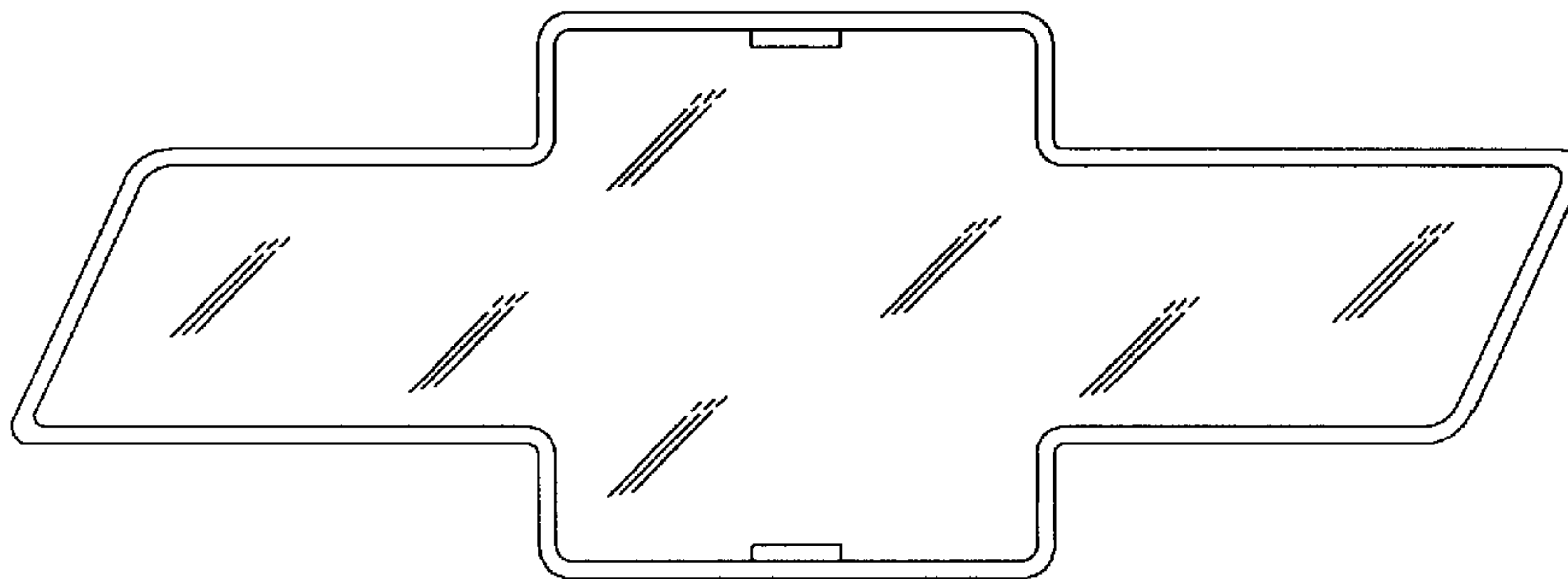

FIG. 2

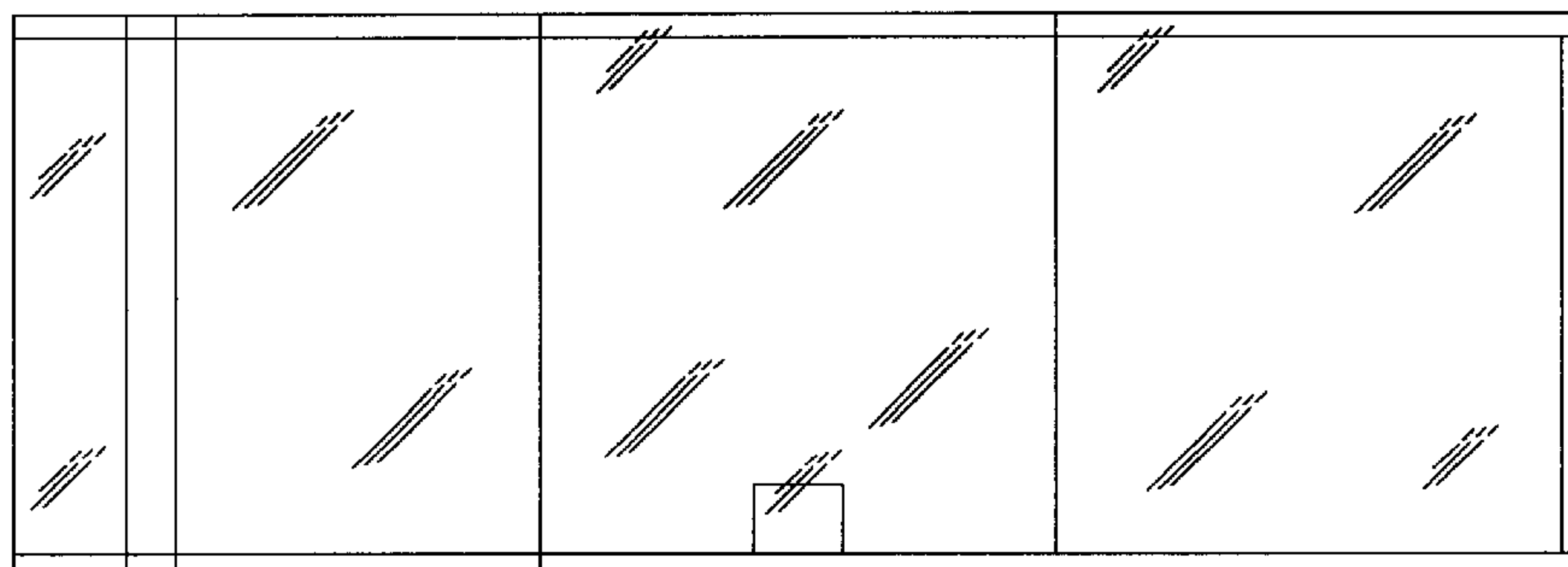

FIG. 3

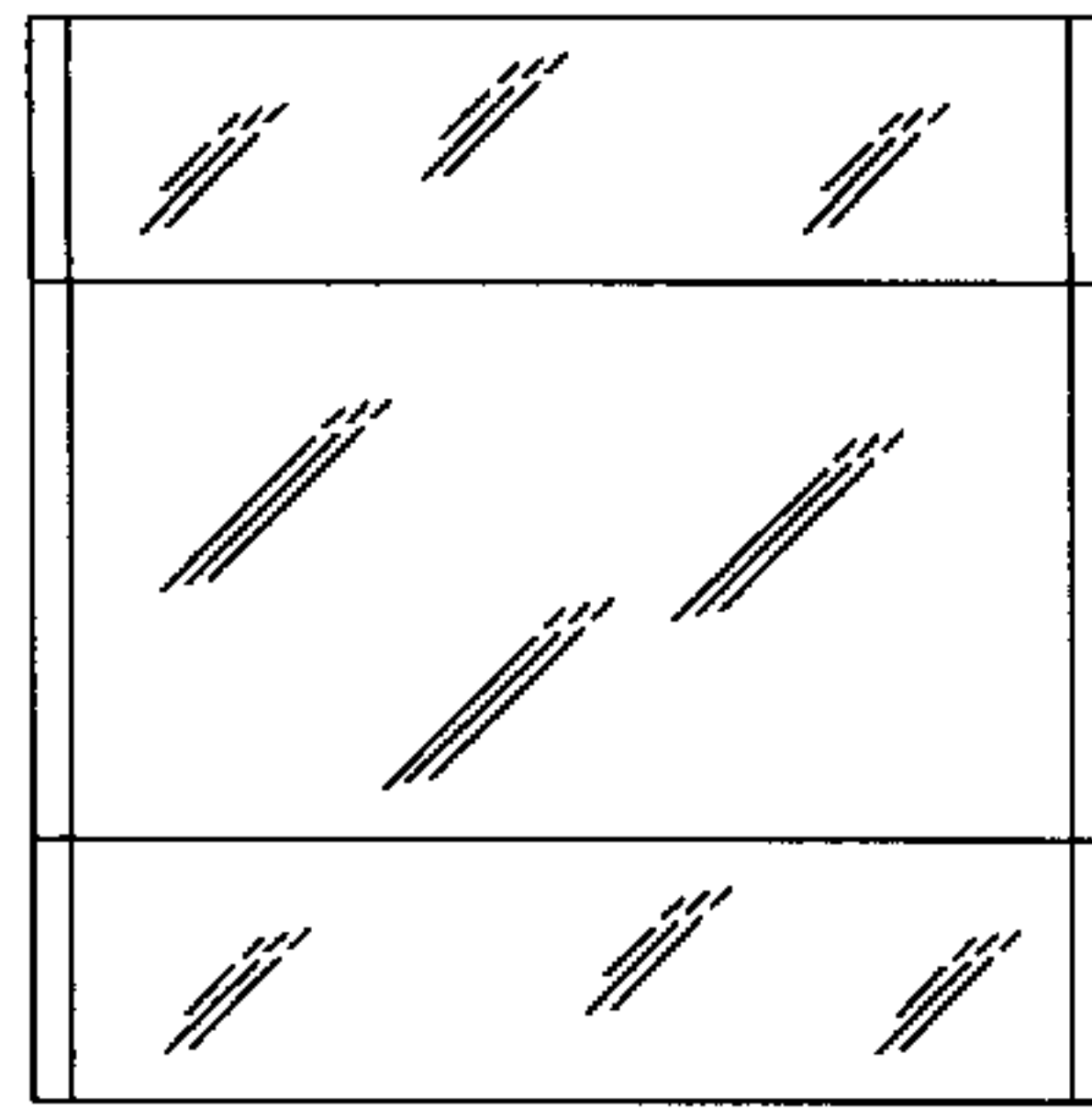

FIG. 4

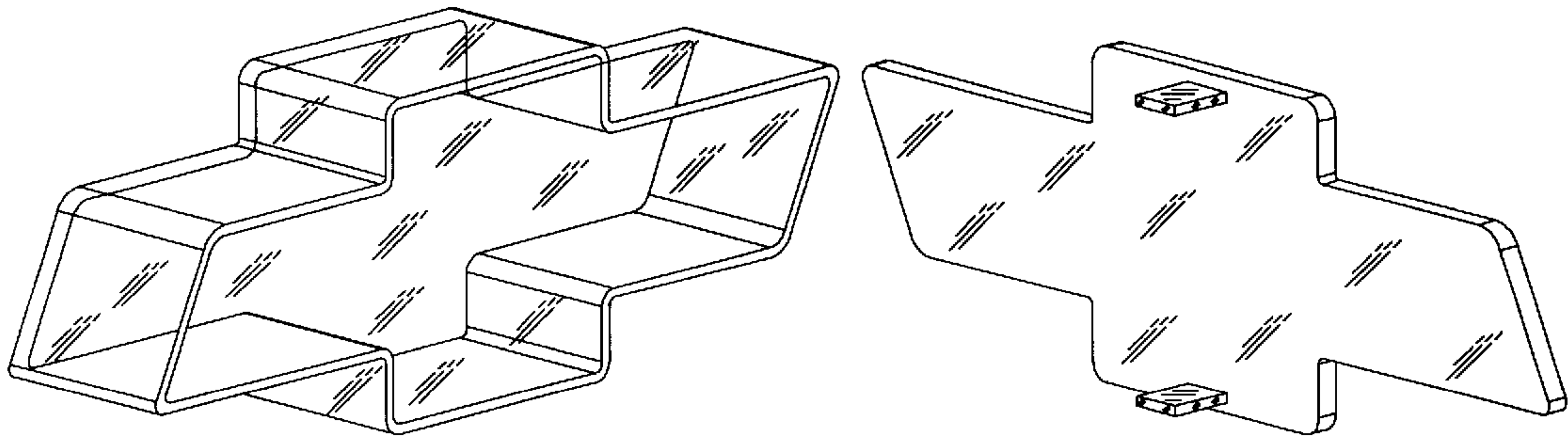

FIG. 5

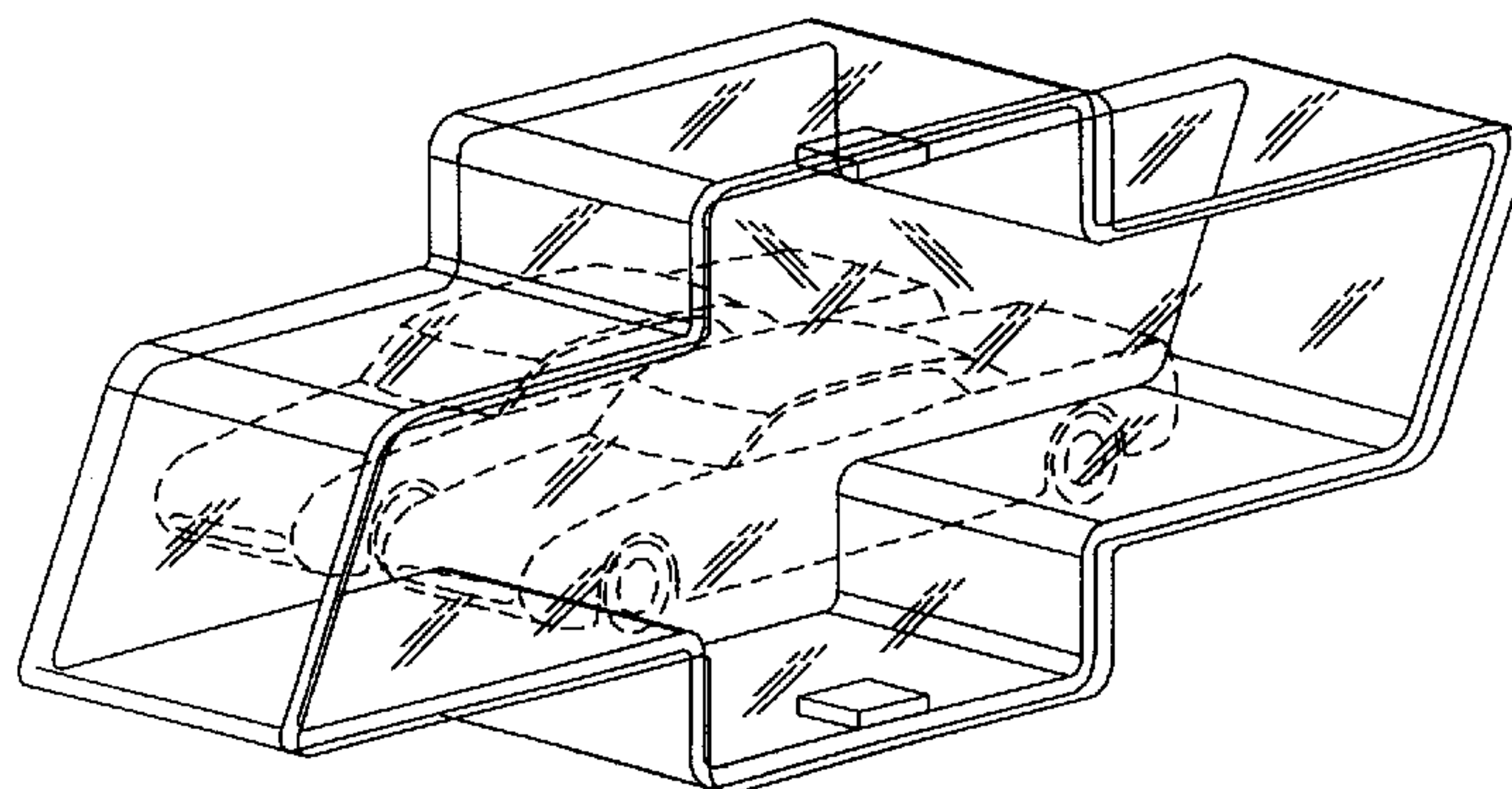

FIG. 6