



US00D481114S

(12) **United States Design Patent**
Cane et al.

(10) **Patent No.:** **US D481,114 S**

(45) **Date of Patent:** **** Oct. 21, 2003**

(54) **STOCK CAR AIR FRESHENER FOR MOTOR VEHICLES**

(76) Inventors: **Frank N. Cane**, 3058 Plumstead Way, San Jose, CA (US) 95148; **Robert D. Stone**, 10 N. Carlton St., Castle Rock, CO (US) 80104

(**) Term: **14 Years**

(21) Appl. No.: **29/162,589**

(22) Filed: **Jun. 18, 2002**

(51) **LOC (7) Cl.** **23-04**

(52) **U.S. Cl.** **D23/367**

(58) **Field of Search** D23/366-9; 239/34-60, 239/211, 53-6; 422/120, 122-4; D12/86, 88, 90-92; D21/548, 549, 562; 296/185

(56) **References Cited**

U.S. PATENT DOCUMENTS

- D390,433 S * 2/1998 Miller
- D390,942 S * 2/1998 Mei
- D408,456 S * 4/1999 Garner
- D417,058 S * 11/1999 Royal et al.
- D419,207 S * 1/2000 Lieberman
- D435,898 S * 1/2001 Yang
- D437,309 S * 2/2001 Brennan
- D462,432 S * 9/2002 Robson
- D465,020 S * 10/2002 Stone et al.

* cited by examiner

Primary Examiner—M. H. Tung

(57) **CLAIM**

The ornamental design for a stock car air freshener for motor vehicles, as shown and described.

DESCRIPTION

FIG. 1 is a perspective view of a stock car air freshener, showing our new design.

FIG. 2 is a perspective view of a second embodiment thereof;

FIG. 3 is a front elevational view on an enlarged scale thereof;

FIG. 4 is a rear elevational view on an enlarged scale thereof;

FIG. 5 is a left side elevational view thereof;

FIG. 6 is a right side elevational view thereof;

FIG. 7 is a top plan view on a reduced scale thereof;

FIG. 8 is a bottom plan view on a reduced scale thereof;

FIG. 9 is a bottom plan view on a reduced scale of a third embodiment thereof; and,

FIG. 10 is a perspective view thereof, on a greatly reduced scale, the broken line drawing of an air vent grille is for illustrative purposes only and forms no part of the claimed design.

The sole difference between the first and second embodiments is the location of the clip that is on the right side of the first embodiments and on the left side of the second embodiment. The sole difference between the third embodiment and the first and second embodiment is the lack of a clip.

1 Claim, 10 Drawing Sheets

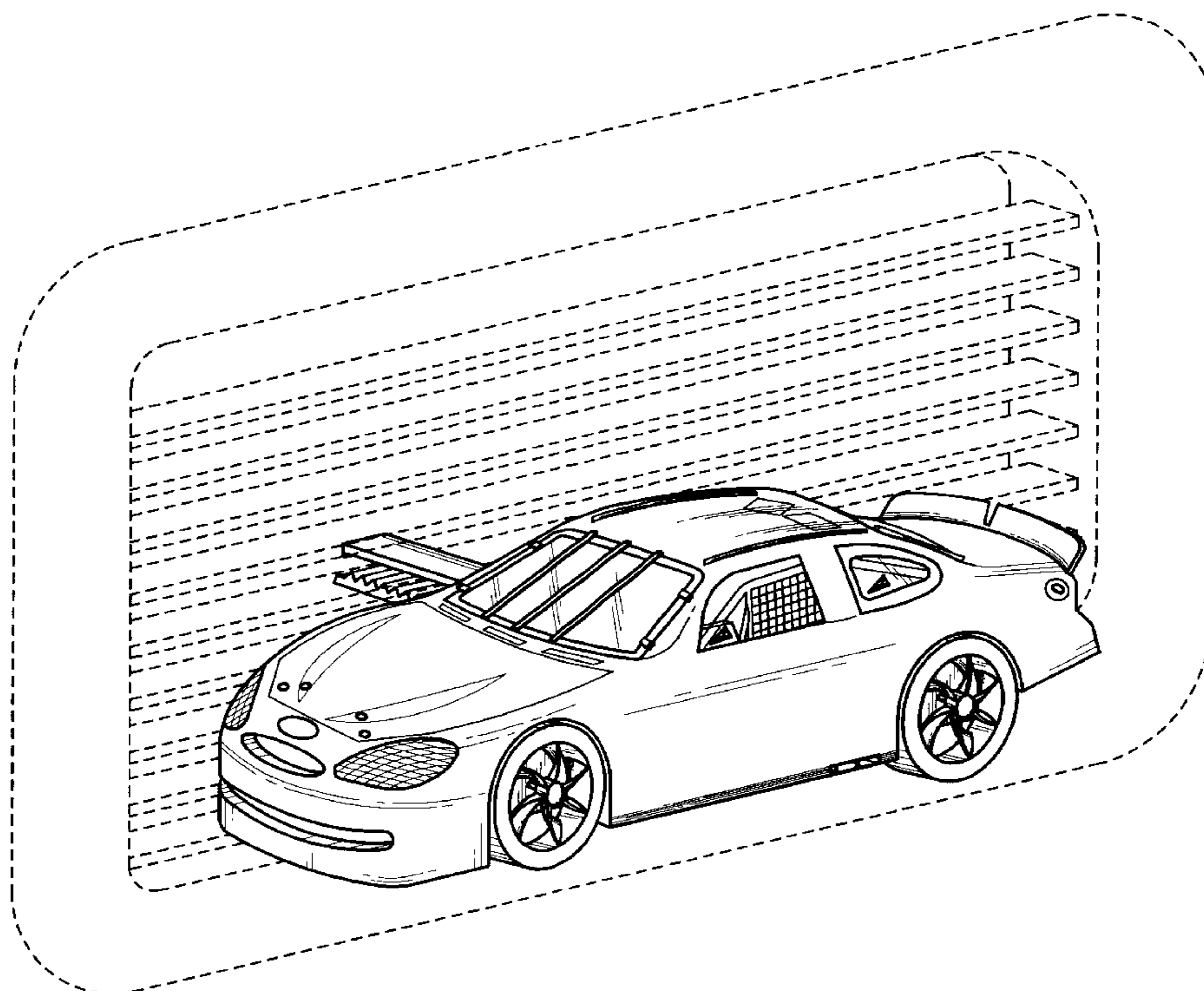

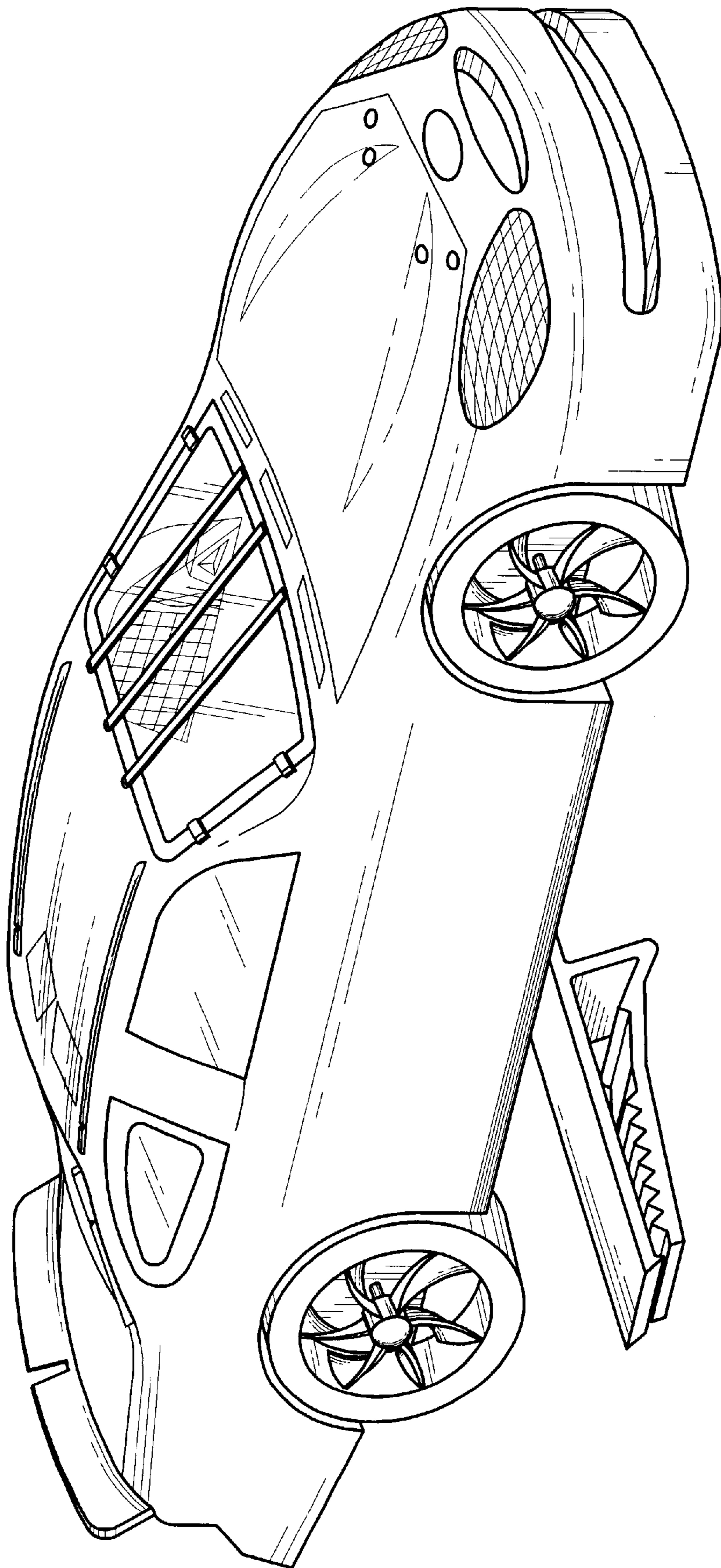

FIG. 1

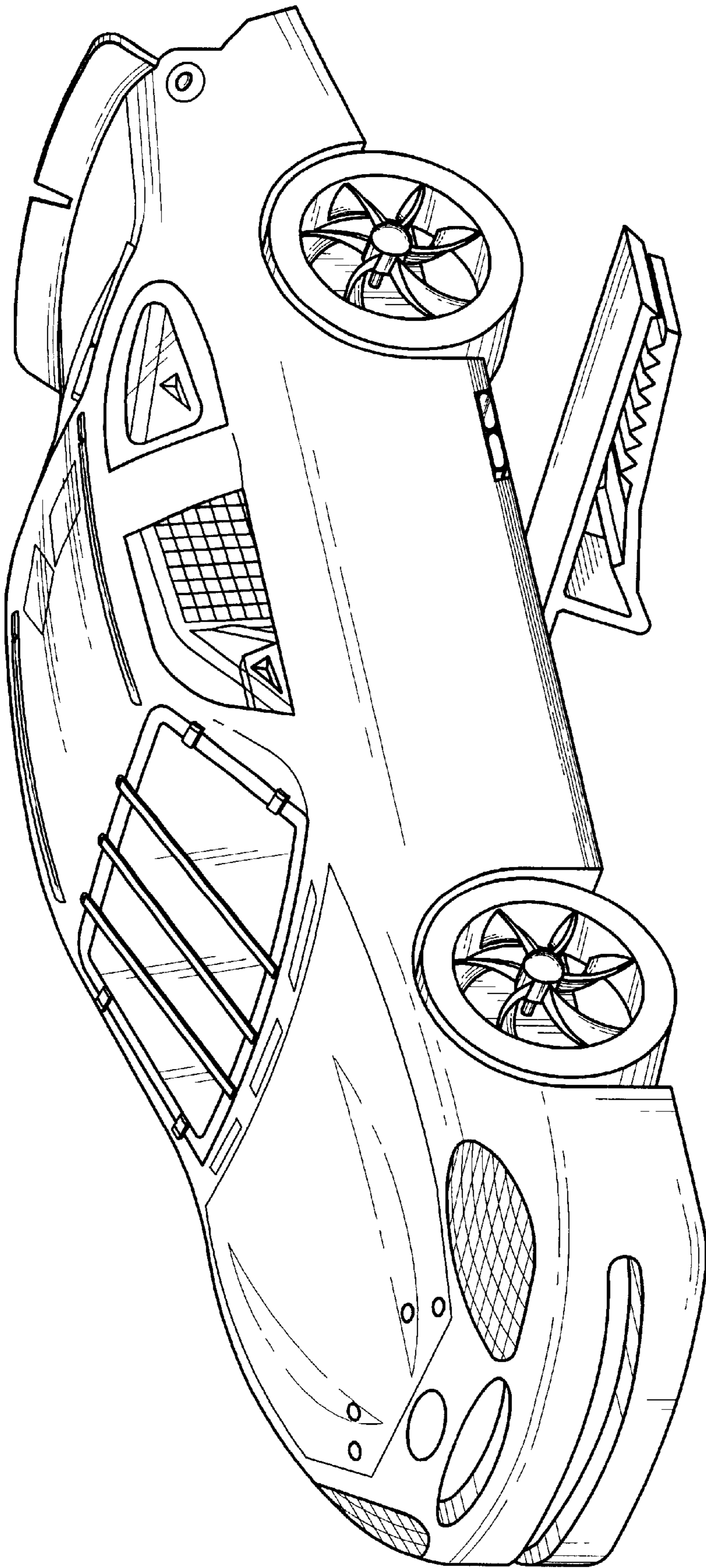

FIG. 2

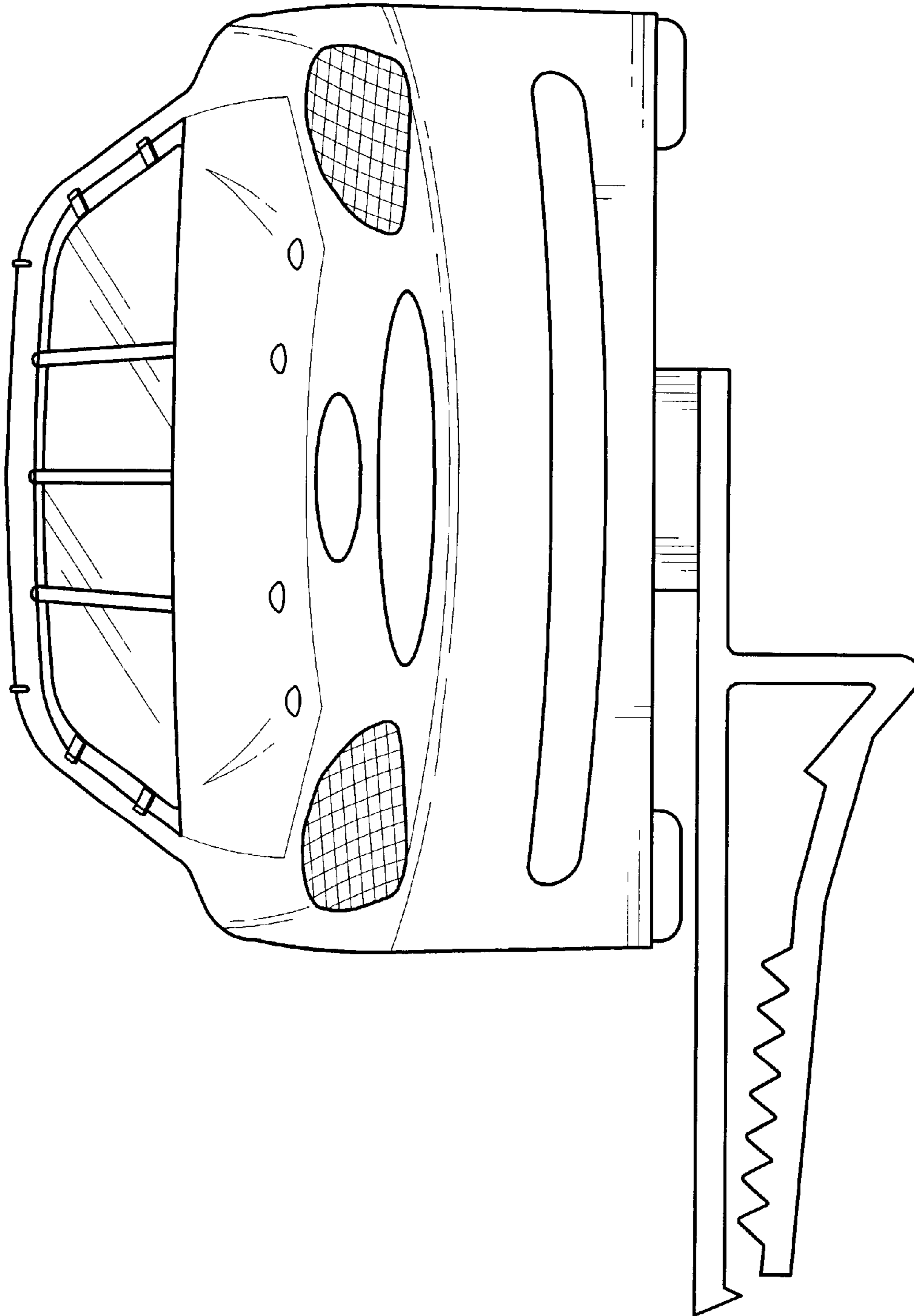

FIG. 3

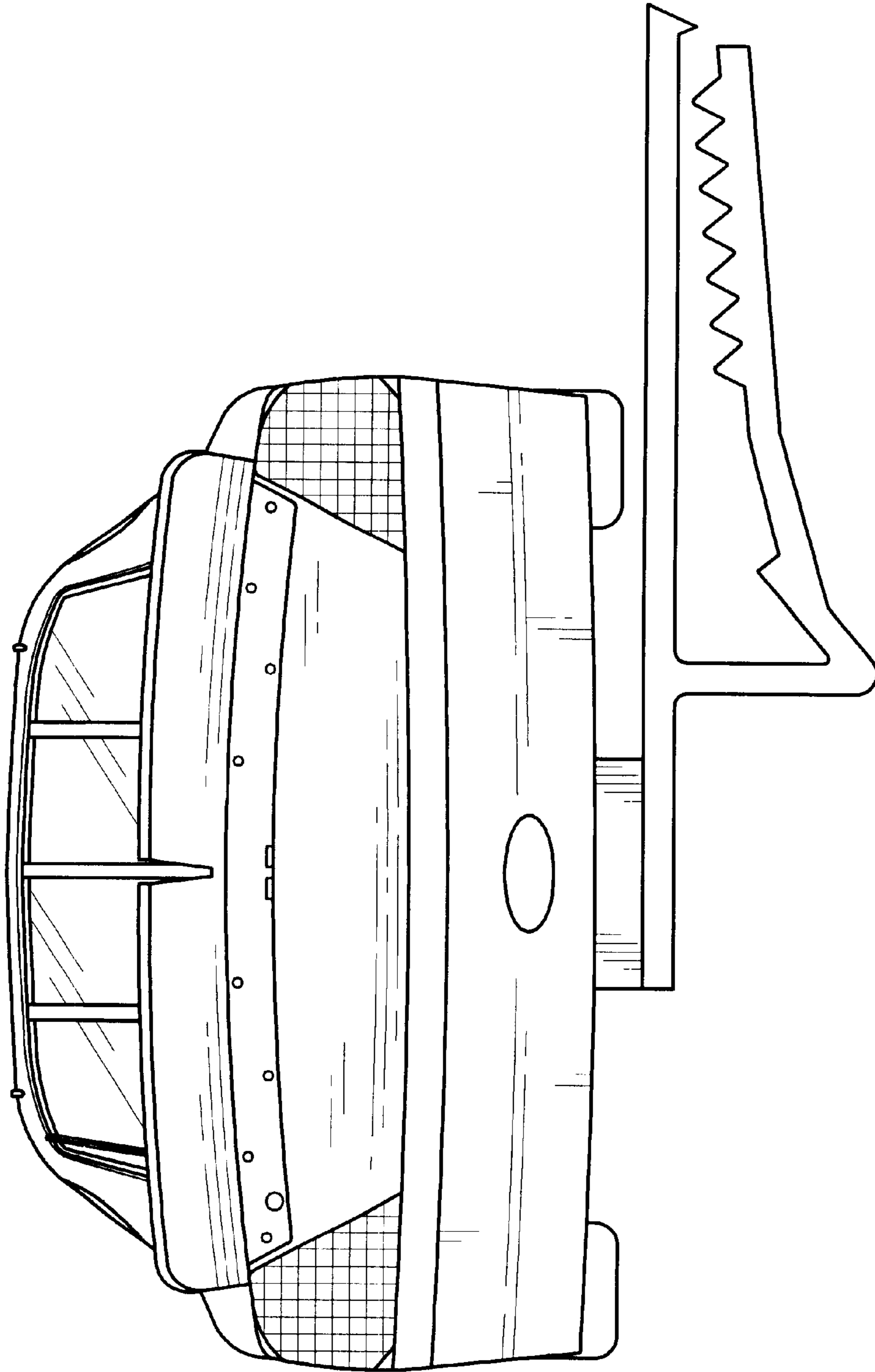

FIG. 4

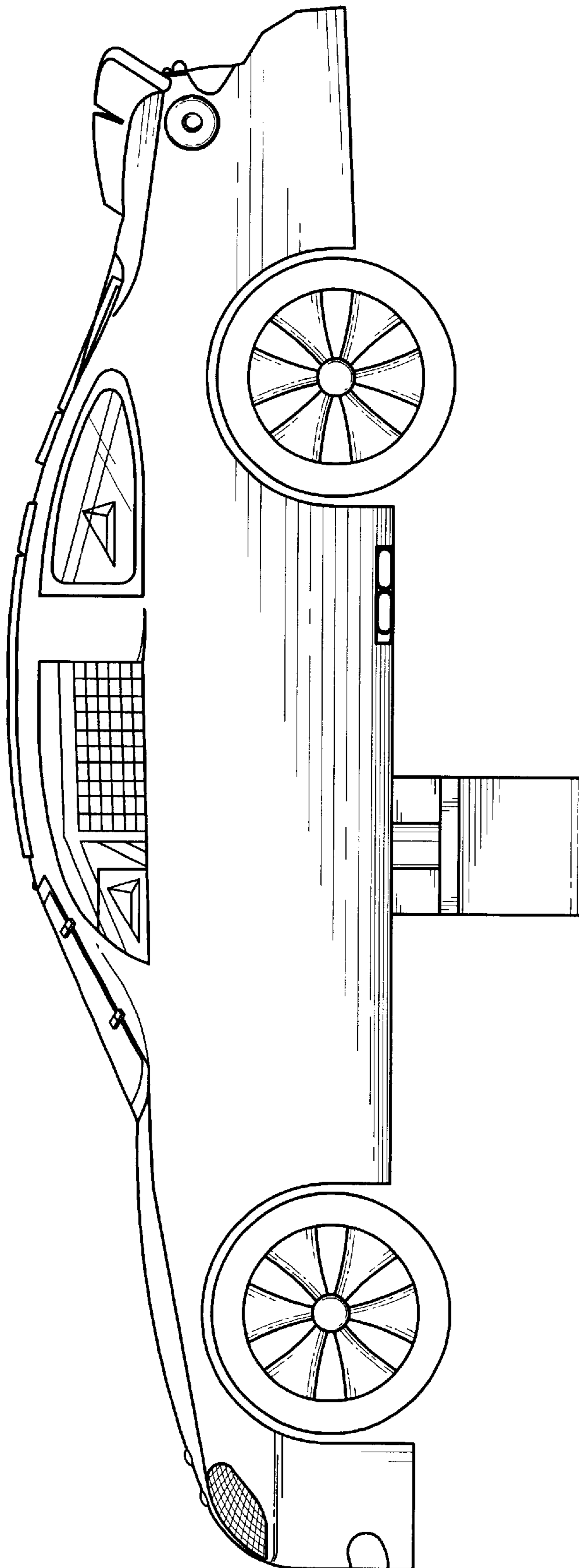

FIG. 5

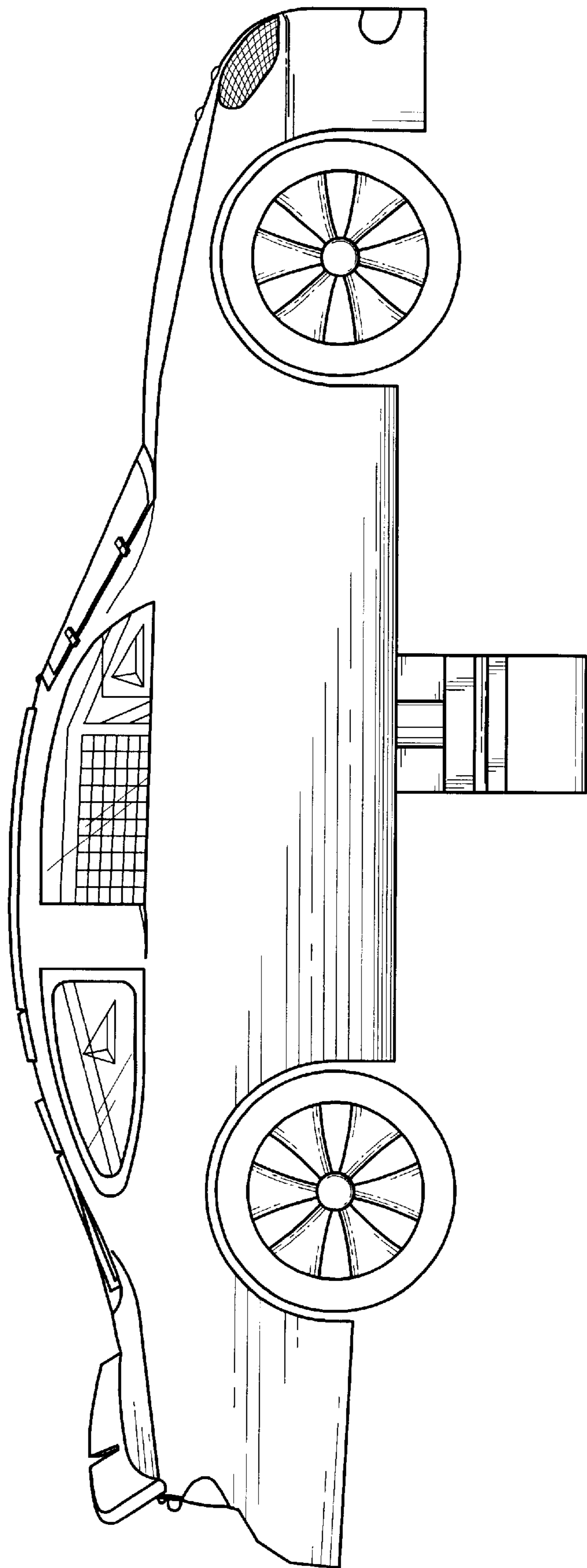

FIG. 6

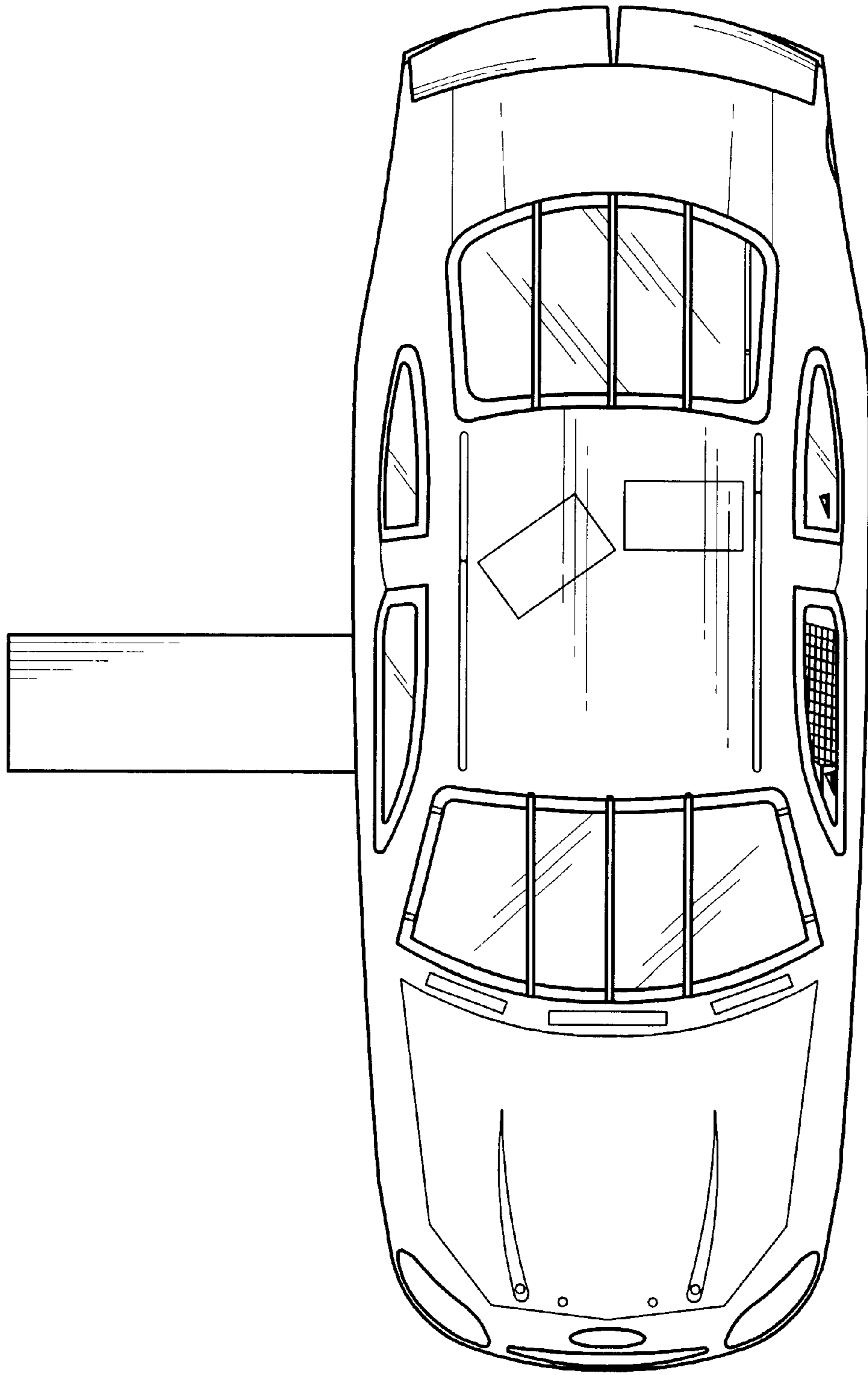

FIG. 7

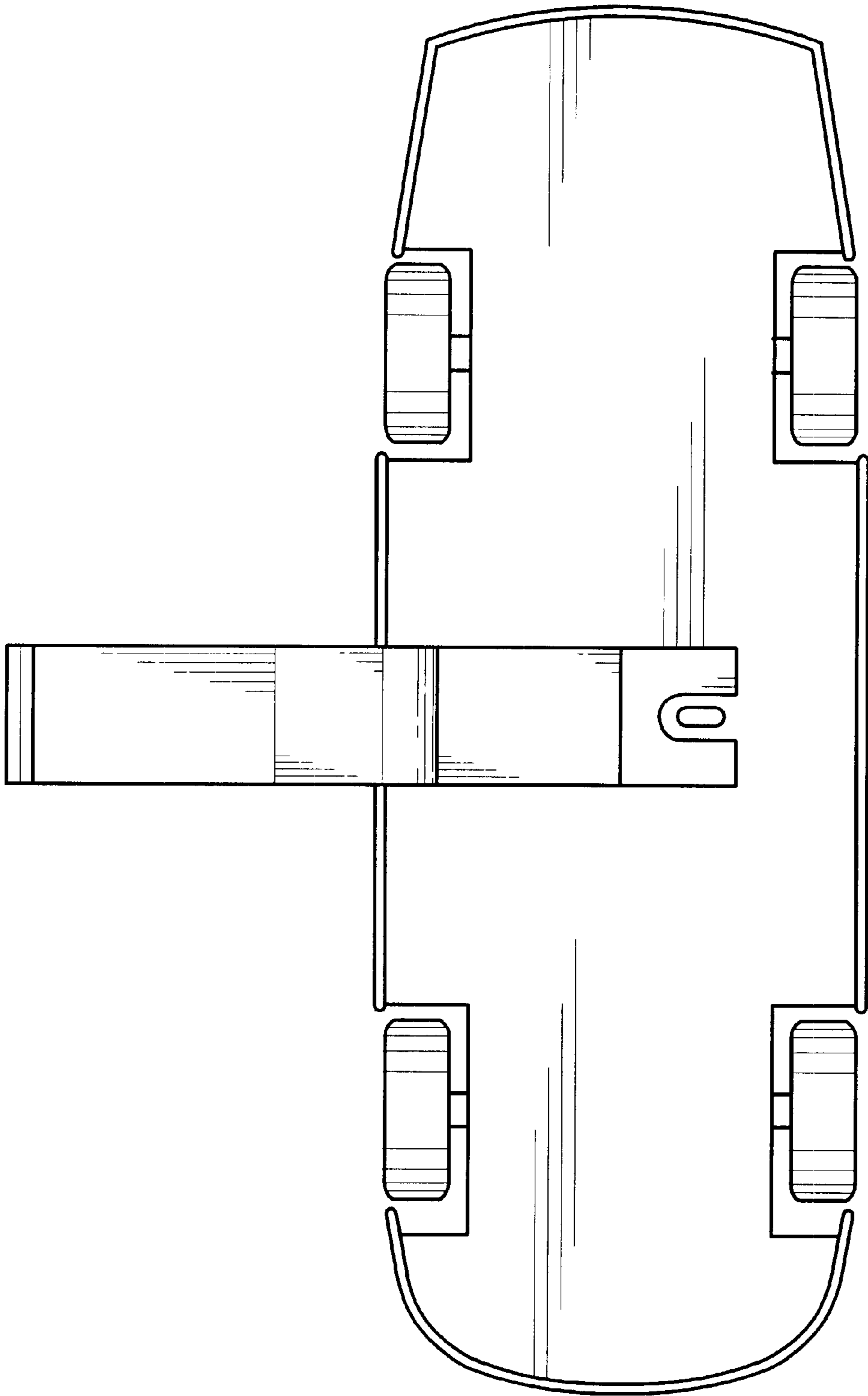

FIG. 8

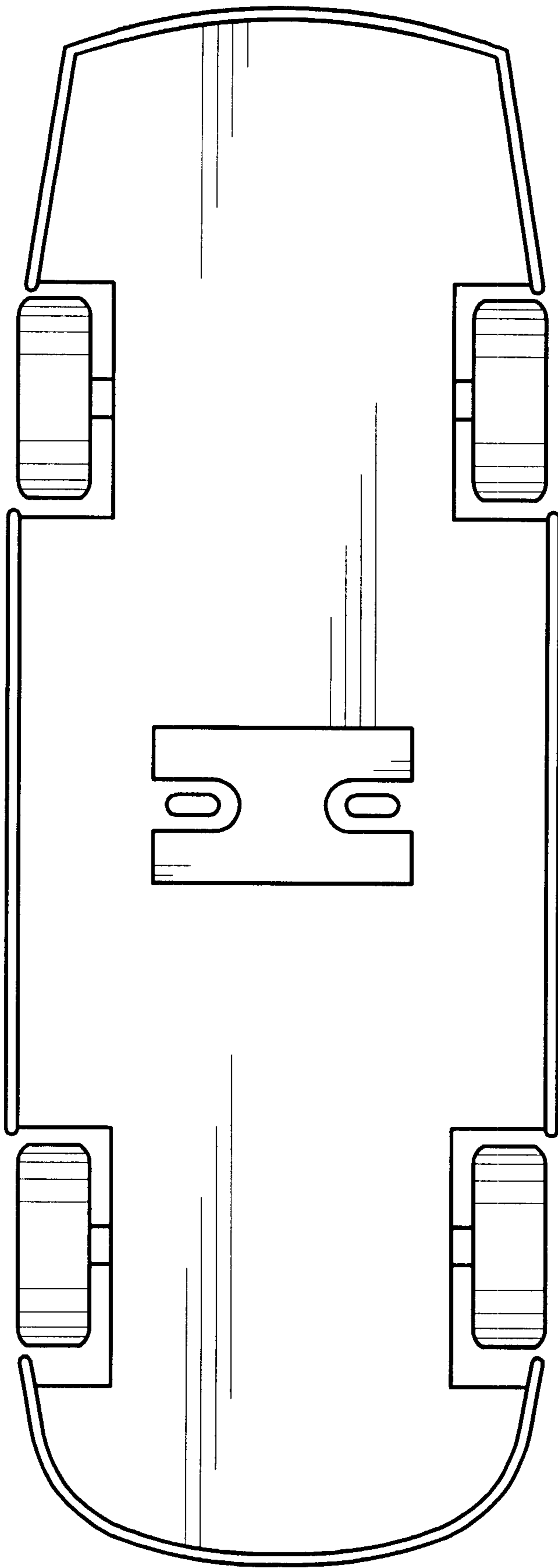

FIG. 9

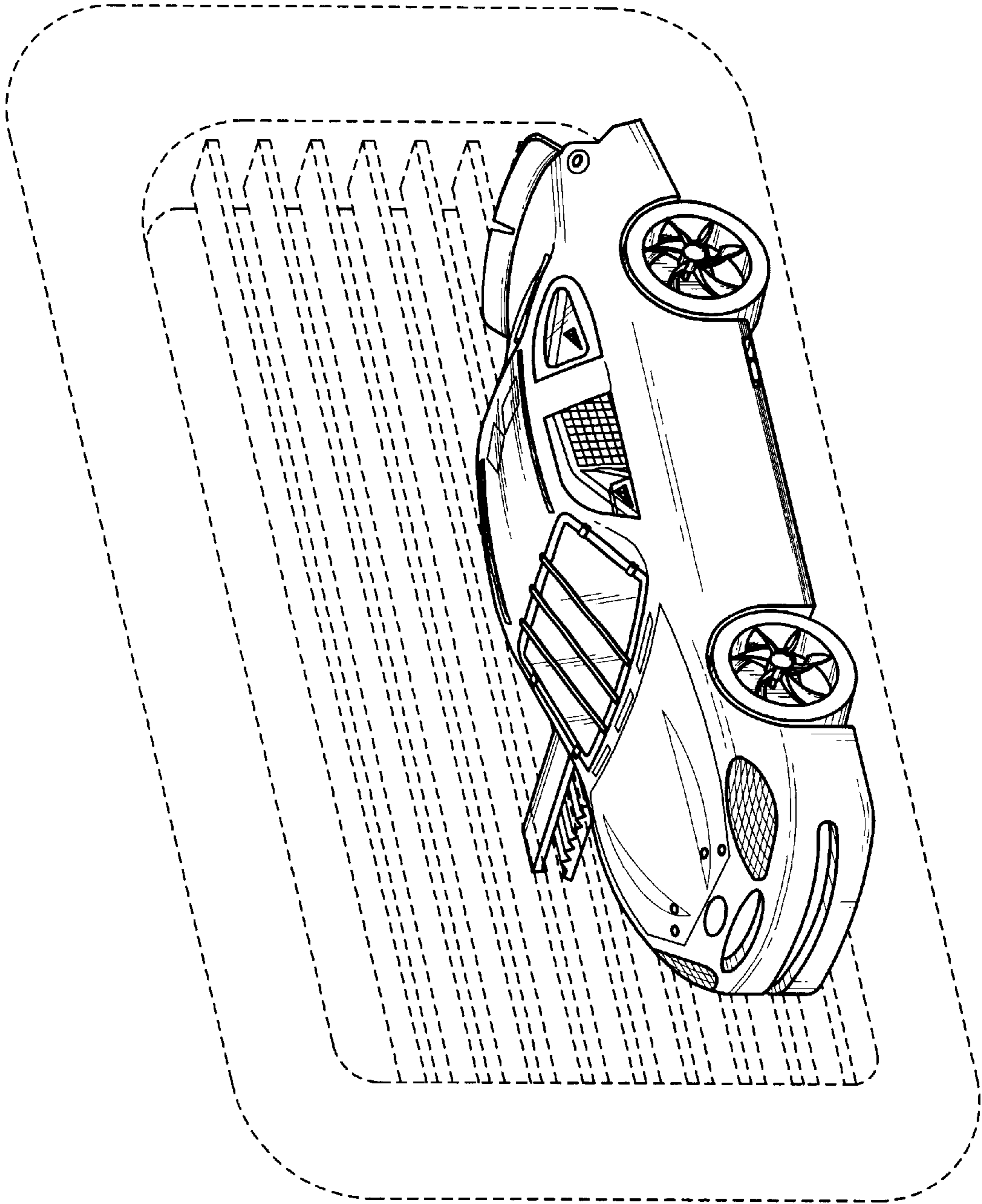

FIG. 10