



US00D480858S

(12) **United States Design Patent** (10) **Patent No.:** **US D480,858 S**
Sellar (45) **Date of Patent:** **** Oct. 14, 2003**

(54) **INDUSTRIAL TRUCK**

(75) Inventor: **Dawson Sellar**, Kirkeudbright (GB)

(73) Assignee: **Linde Aktiengesellschaft** (DE)

(**) Term: **14 Years**

(21) Appl. No.: **29/165,977**

(22) Filed: **Aug. 19, 2002**

(30) **Foreign Application Priority Data**

Feb. 19, 2002 (DE) 4 02 01 523

(51) **LOC (7) Cl.** **12-05**

(52) **U.S. Cl.** **D34/34**

(58) **Field of Search** D34/28, 33, 34;
187/222, 226, 237, 238; 414/679, 680;
180/89.12

(56) **References Cited**

U.S. PATENT DOCUMENTS

3,587,784 A	*	6/1971	Tait	187/226
D222,694 S	*	12/1971	Goodacre	D34/34
3,951,471 A	*	4/1976	Langenstein	384/45
D313,100 S	*	12/1990	Soederberg	D34/28
5,501,297 A	*	3/1996	Josephs	187/222
D370,761 S	*	6/1996	Stark	D34/34
D371,669 S	*	7/1996	Yoon	D34/34

D389,981 S	*	1/1998	Donaldson	D34/34
D389,982 S	*	1/1998	Kim	D34/34
D393,134 S	*	3/1998	Mariano	D34/34
D393,517 S	*	4/1998	Kim et al.	D34/34
D407,176 S	*	3/1999	Henshaw et al.	D34/34
D407,177 S	*	3/1999	Henshaw et al.	D34/34
5,890,562 A	*	4/1999	Bartels et al.	187/224
6,089,353 A	*	7/2000	Bartels et al.	187/224
D440,373 S	*	4/2001	Meinhardt	D34/34

* cited by examiner

Primary Examiner—Cynthia E. Ramirez
(74) *Attorney, Agent, or Firm*—Webb Ziesenheim Logsdon Orkin & Hanson, P.C.

(57) **CLAIM**

The ornamental design for an industrial truck, as shown.

DESCRIPTION

FIG. 1 is a perspective view taken from the right front of an industrial truck showing my new design;
 FIG. 2 is a perspective view taken from the left rear of the industrial truck of FIG. 1;
 FIG. 3 is a front elevational view thereof;
 FIG. 4 is a top plan view thereof;
 FIG. 5 is a right side elevational view thereof;
 FIG. 6 is a rear elevational view thereof; and,
 FIG. 7 is a bottom plan view thereof.

1 Claim, 7 Drawing Sheets

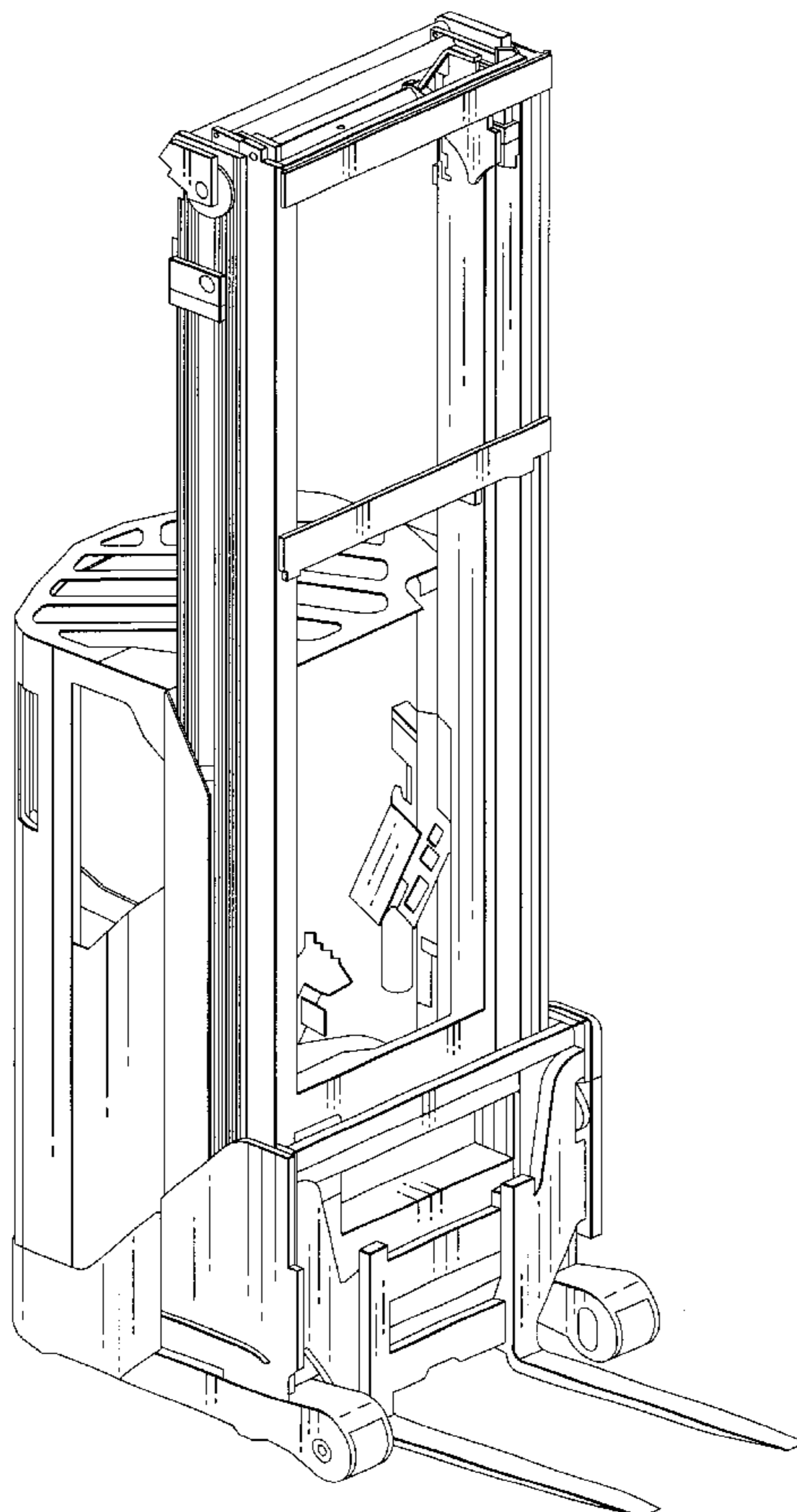

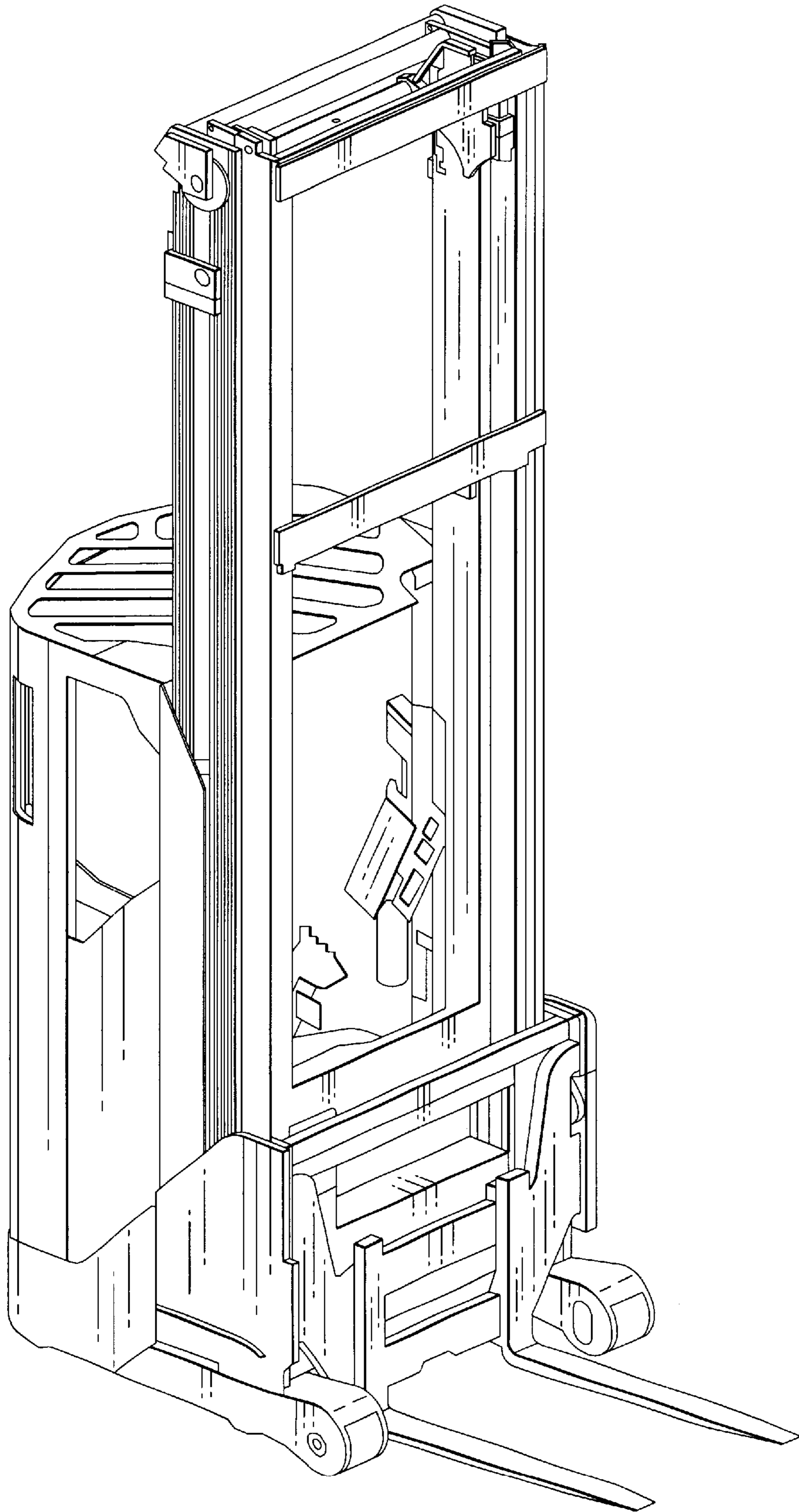

FIG. 1

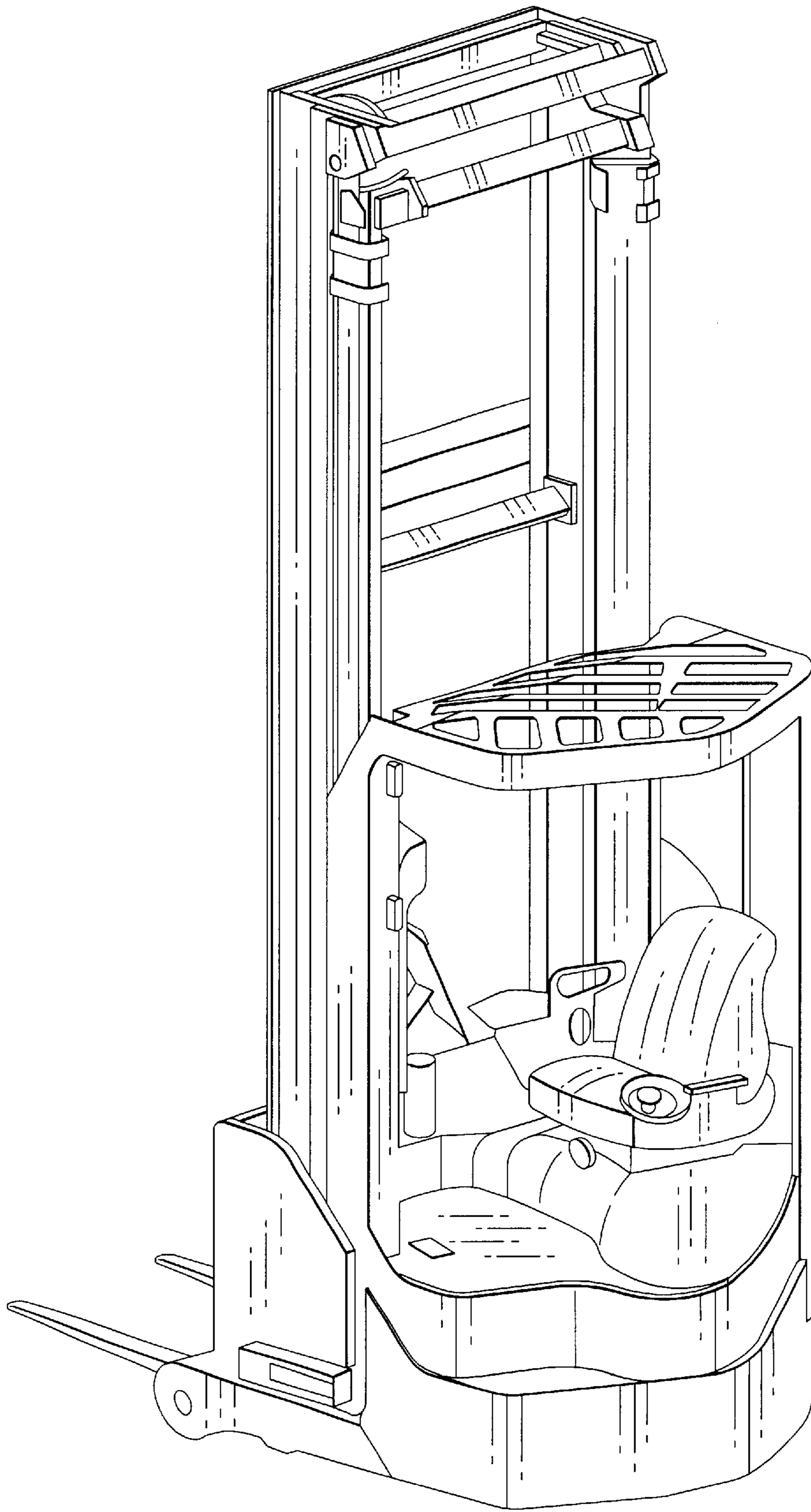

FIG. 2

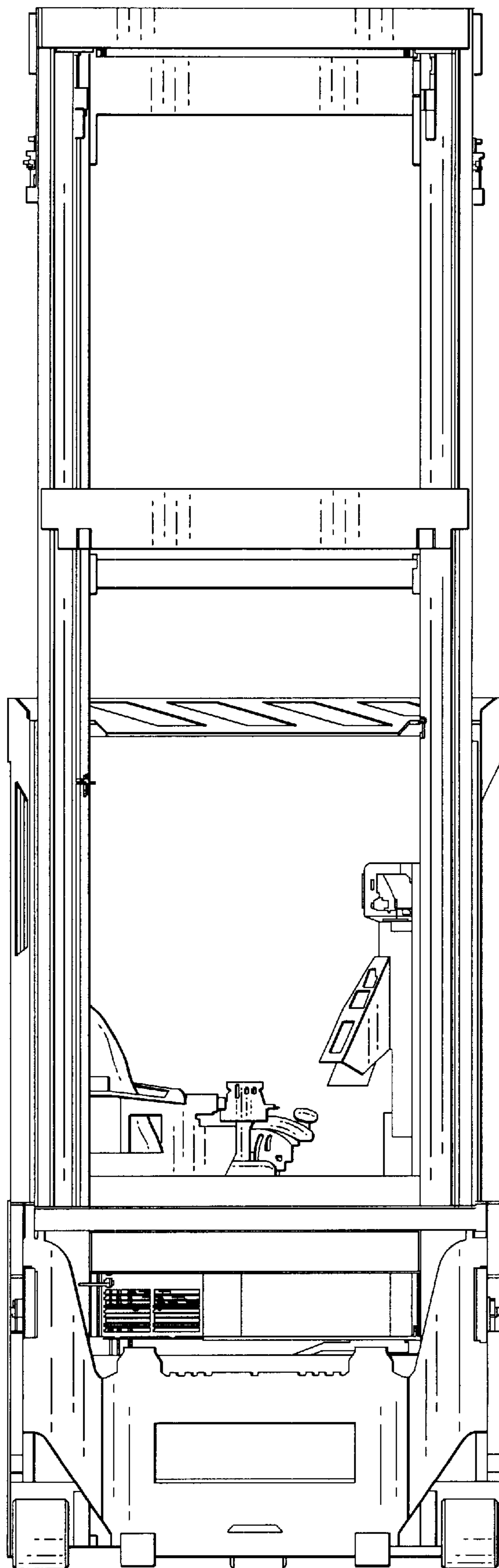

FIG. 3

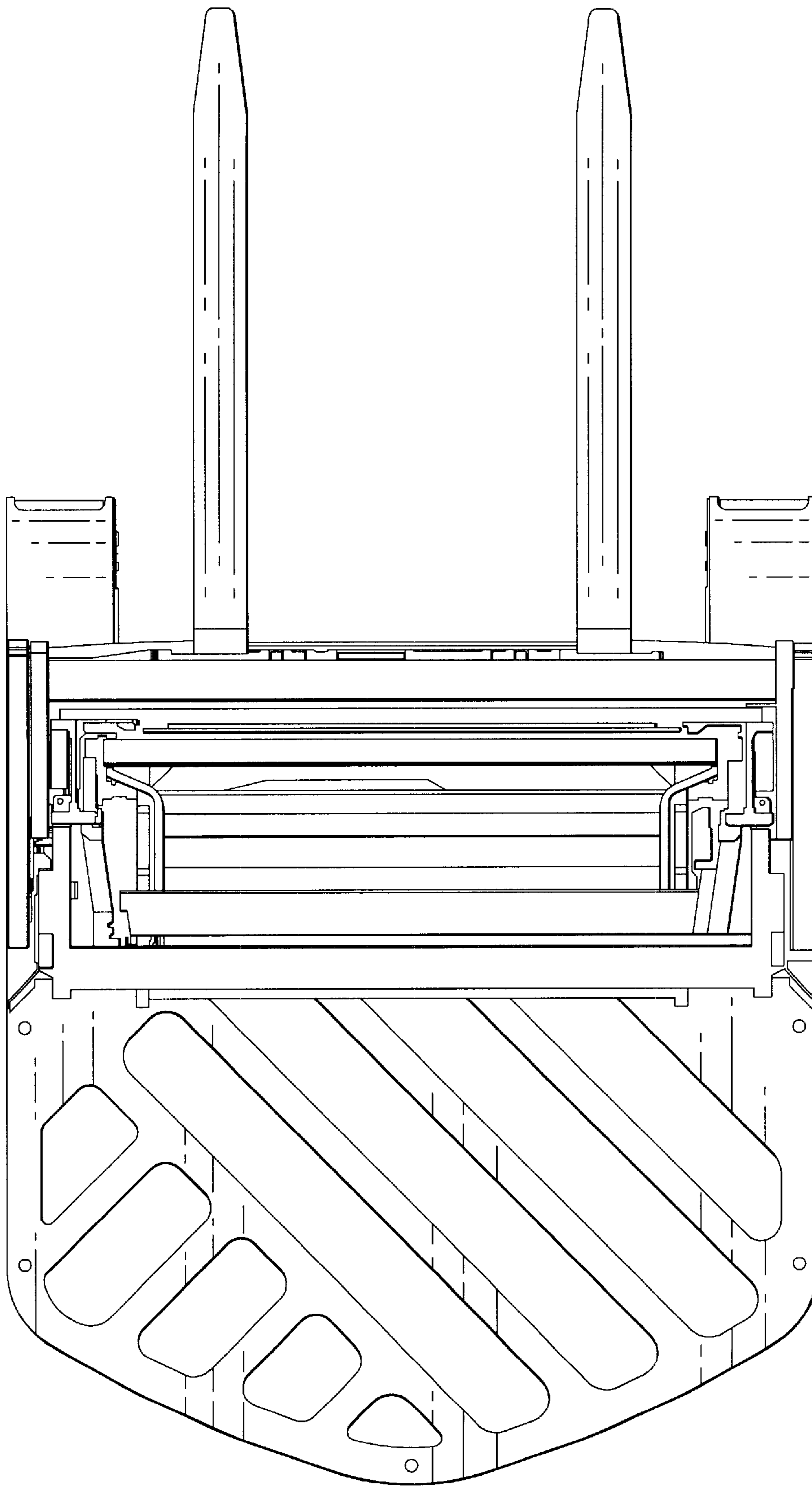

FIG. 4

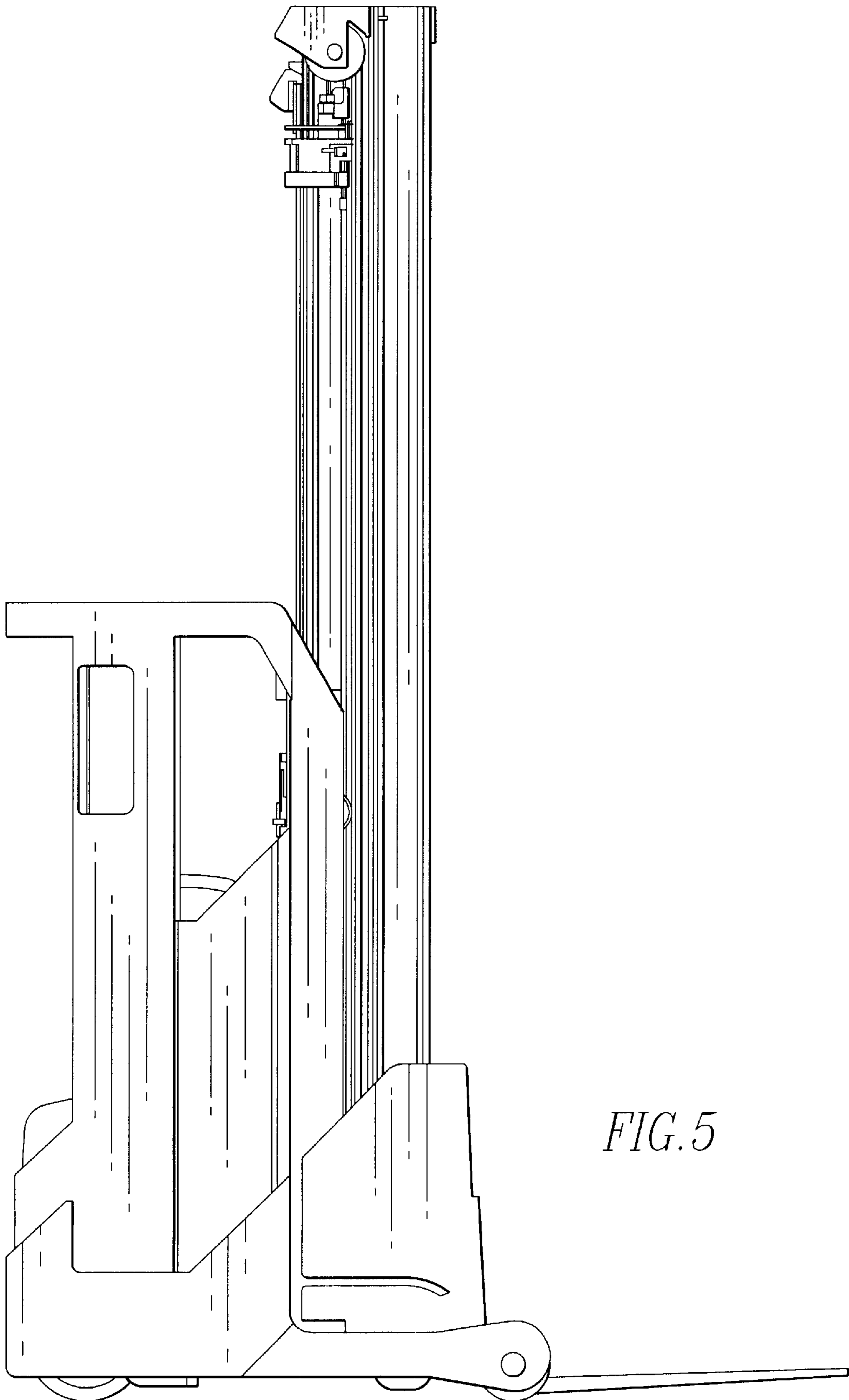

FIG. 5

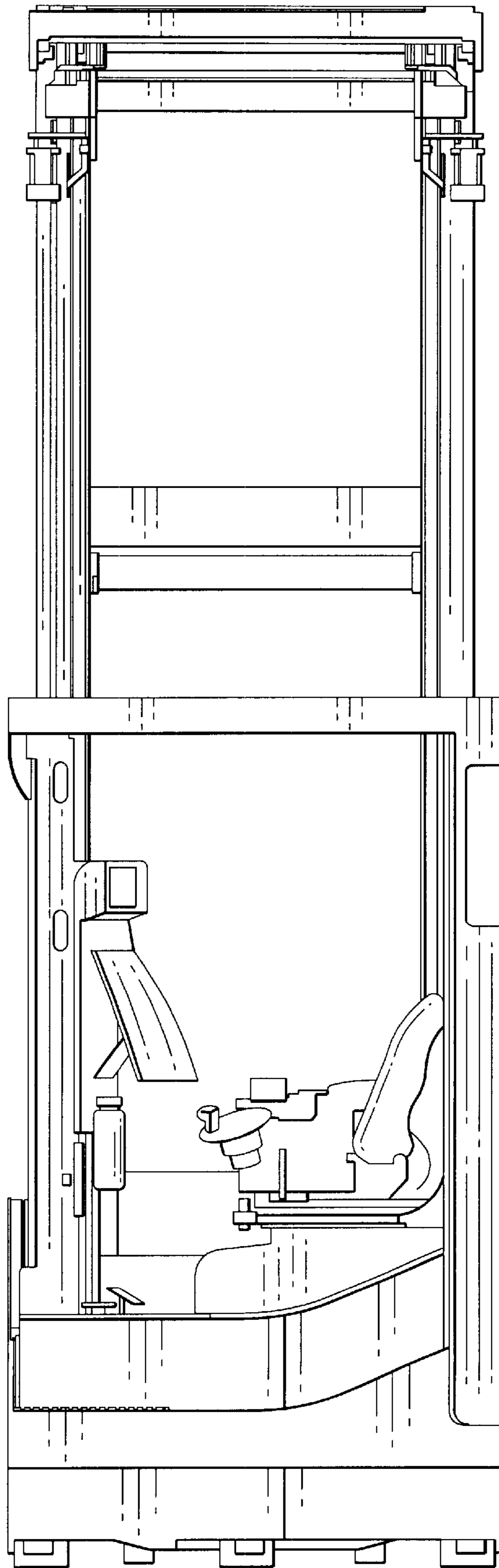

FIG. 6

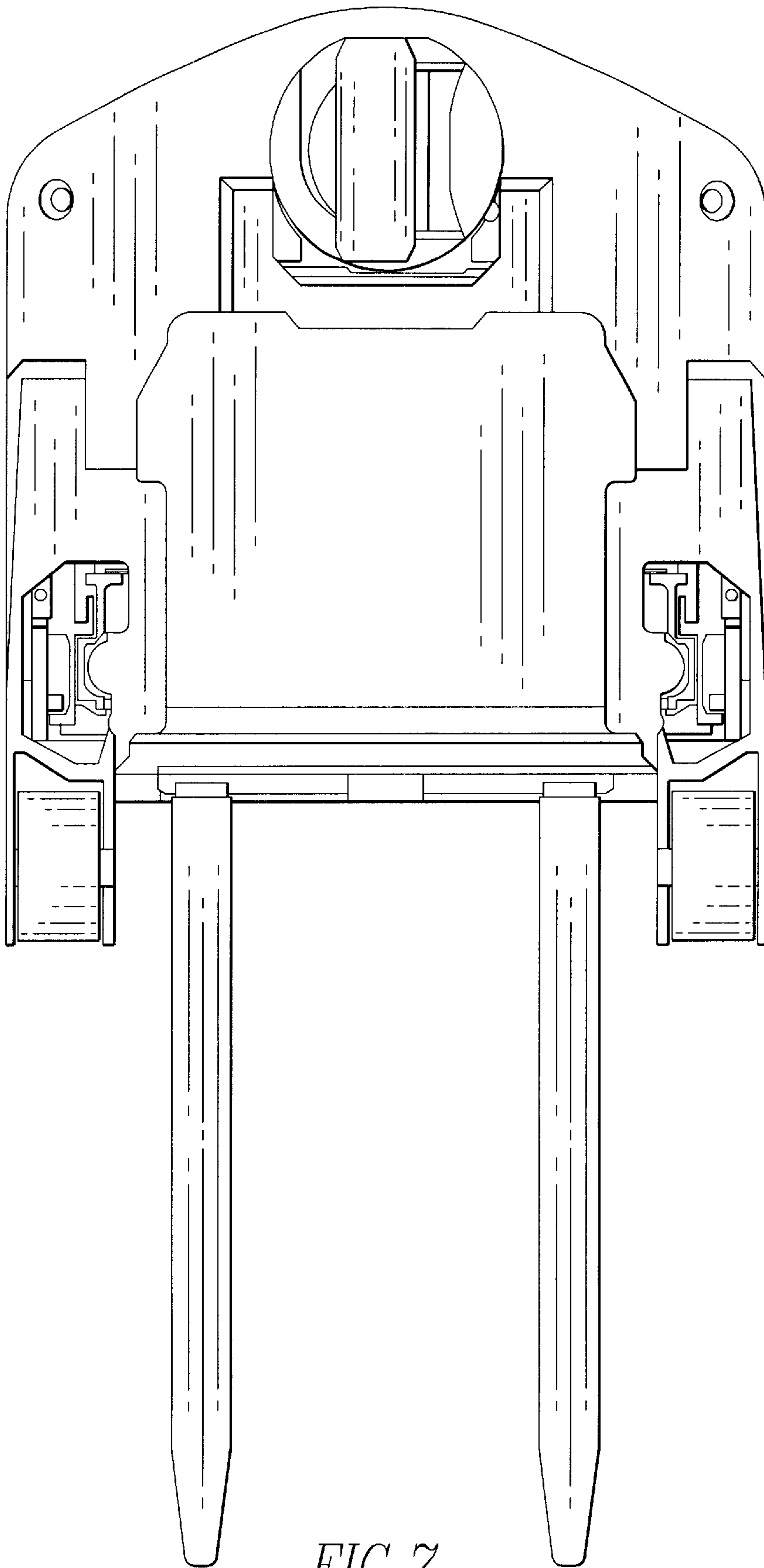

FIG. 7