



US00D480783S

(12) **United States Design Patent**  
**Sciulli et al.**

(10) **Patent No.:** **US D480,783 S**

(45) **Date of Patent:** **\*\* Oct. 14, 2003**

(54) **ORIFICE MOUNT FOR HIGH-PRESSURE  
FLUID JET SYSTEMS**

(75) Inventors: **Felix M. Sciulli**, Issaquah, WA (US);  
**Mohamed A. Hashish**, Bellevue, WA  
(US); **Steven J. Craigen**, Auburn, WA  
(US); **Bruce M. Schuman**, Kent, WA  
(US)

(73) Assignee: **Flow International Corporation**, Kent,  
WA (US)

(\*\*) Term: **14 Years**

(21) Appl. No.: **29/158,318**

(22) Filed: **Apr. 1, 2002**

(51) **LOC (7) Cl.** ..... **23-01**

(52) **U.S. Cl.** ..... **D23/213**

(58) **Field of Search** ..... D23/213; D15/124,  
D15/126; 239/596, 589, 433, 434; 4/541.5,  
541.6

(56) **References Cited**

**U.S. PATENT DOCUMENTS**

D285,333 S *	8/1986	Enk	.....	D23/213
4,951,429 A	8/1990	Hashish et al.	.....	51/439
5,018,670 A	5/1991	Chalmers	.....	239/433
5,092,085 A	3/1992	Hashish et al.	.....	51/439
5,144,766 A	9/1992	Hashish et al.	.....	51/439
5,320,289 A	6/1994	Hashish et al.	.....	239/434
5,643,058 A	7/1997	Erichsen et al.	.....	451/99
5,851,139 A	12/1998	Xu	.....	451/102
6,267,788 B1 *	7/2001	Anderson	.....	239/589
6,283,832 B1	9/2001	Shepherd	.....	451/40
6,299,078 B1 *	10/2001	Fugere	.....	239/596

**FOREIGN PATENT DOCUMENTS**

DE G 94 02 938.5 5/1994

**OTHER PUBLICATIONS**

Ramulu et al., "Abrasive Waterjet Drilling and Cutting Mechanisms in Continuous-Fiber Ceramic Composites," in *Proceedings of the 9<sup>th</sup> American Waterjet Conference*, WaterJet Technology Association, Dearborn, MI, Aug. 23-26, 1997, pp. 109-132.

Sheridan et al., "Microstructural and Mechanical Characterization of Threaded Composite Tubes Machined Using AWJ Cutting," in *Proceedings of the 8<sup>th</sup> American Water Jet Conference*, WaterJet Technology Association, Houston, TX, Aug. 26-29, 1995, pp. 245-258.

\* cited by examiner

*Primary Examiner*—Robin V. Taylor

(74) *Attorney, Agent, or Firm*—Seed Intellectual Property Law Group PLLC

(57) **CLAIM**

The ornamental design for an orifice mount for high-pressure fluid jet systems, as shown and described.

**DESCRIPTION**

FIG. 1 is a front perspective view of an orifice mount for high-pressure fluid jet systems, showing our new design.

FIG. 2 is a side elevational view thereof, all other side, front, and rear elevational views being identical.

FIG. 3 is a top plan view thereof.

FIG. 4 is a bottom plan view thereof.

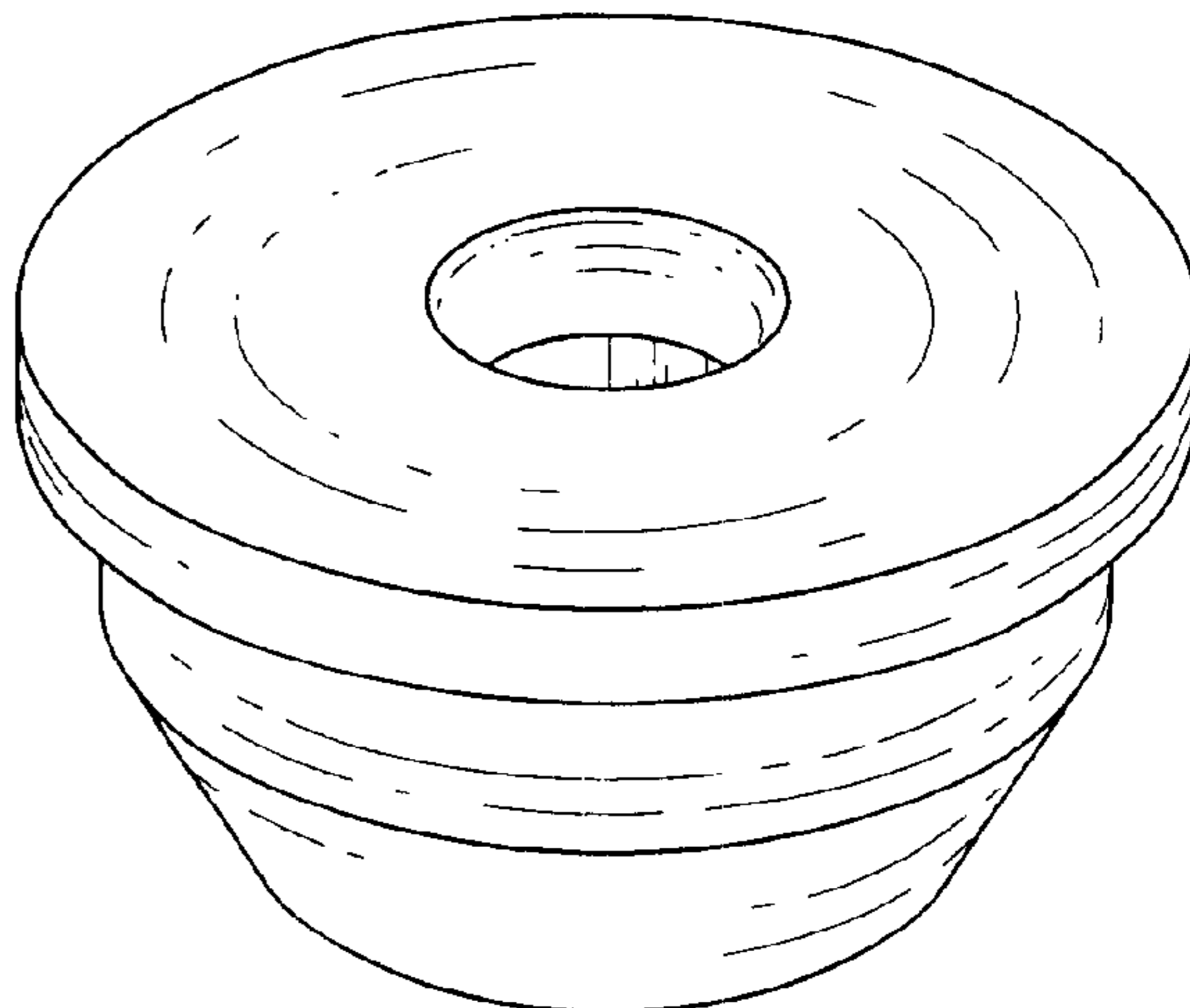
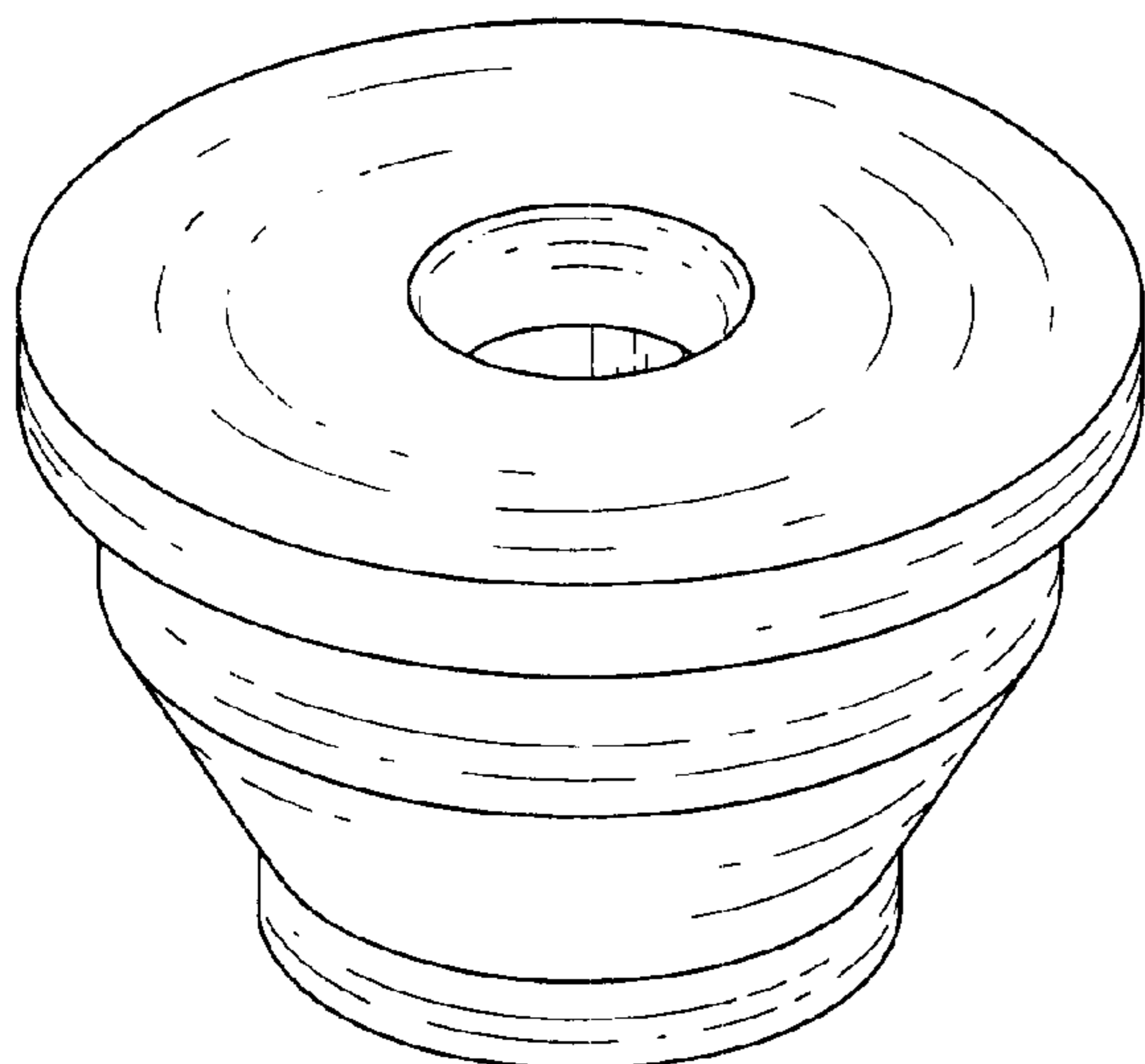
FIG. 5 is a front perspective view of an alternative embodiment of an orifice mount for high-pressure fluid jet systems, showing our new design.

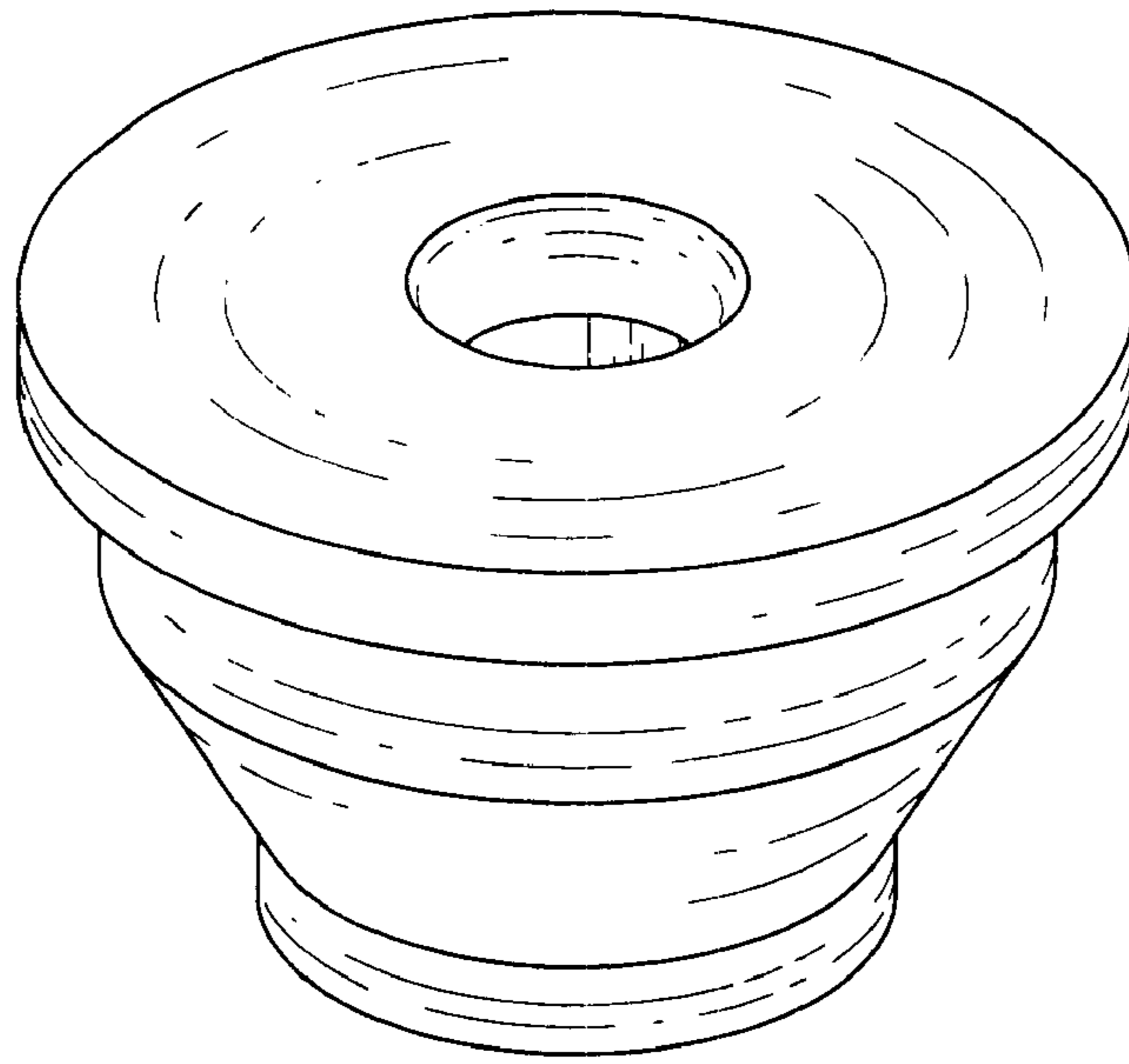
FIG. 6 is a side elevational view thereof, all other side, front, and rear elevational views being identical.

FIG. 7 is a top plan view thereof; and,

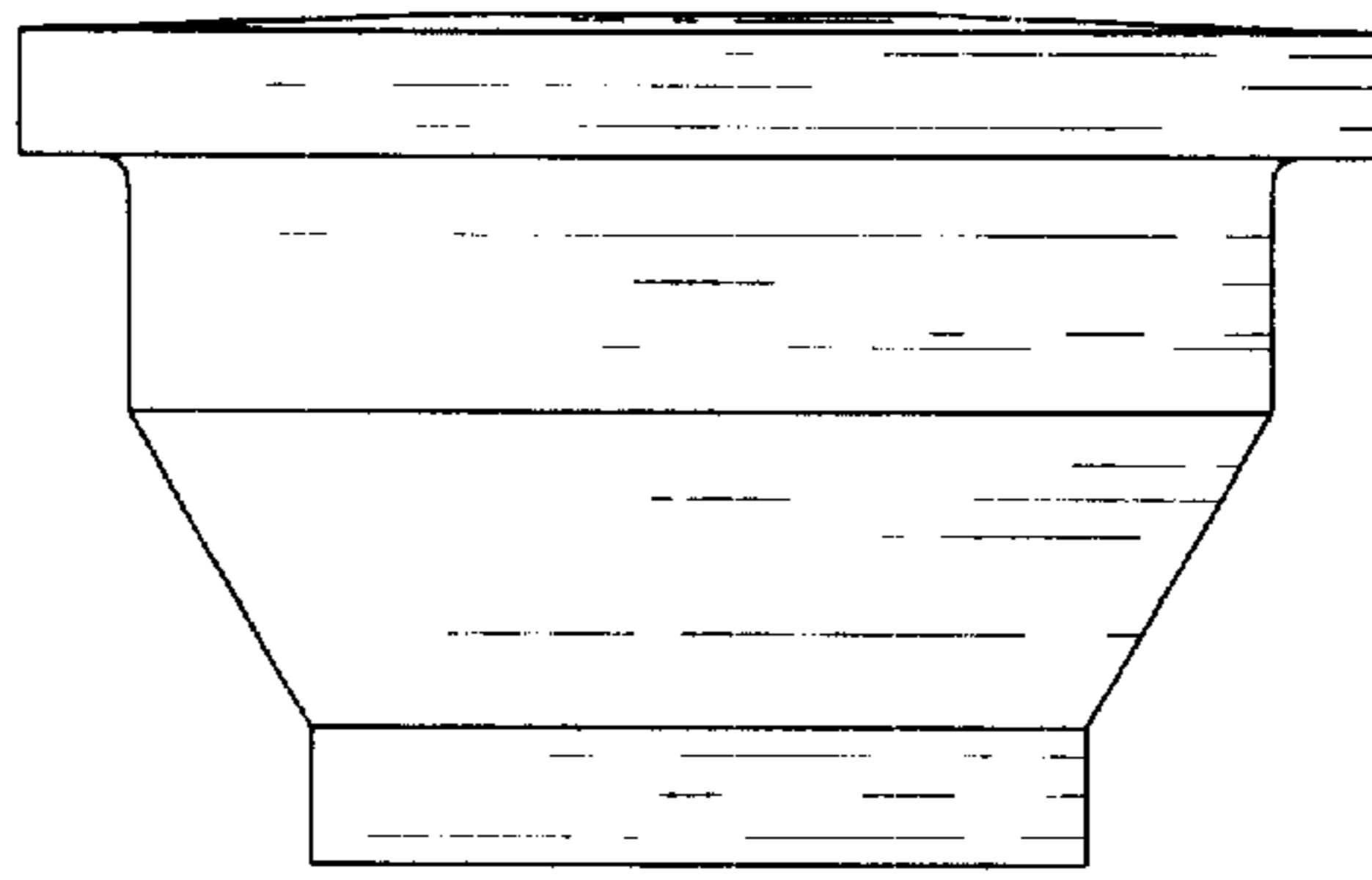
FIG. 8 is a bottom plan view thereof.

**1 Claim, 4 Drawing Sheets**

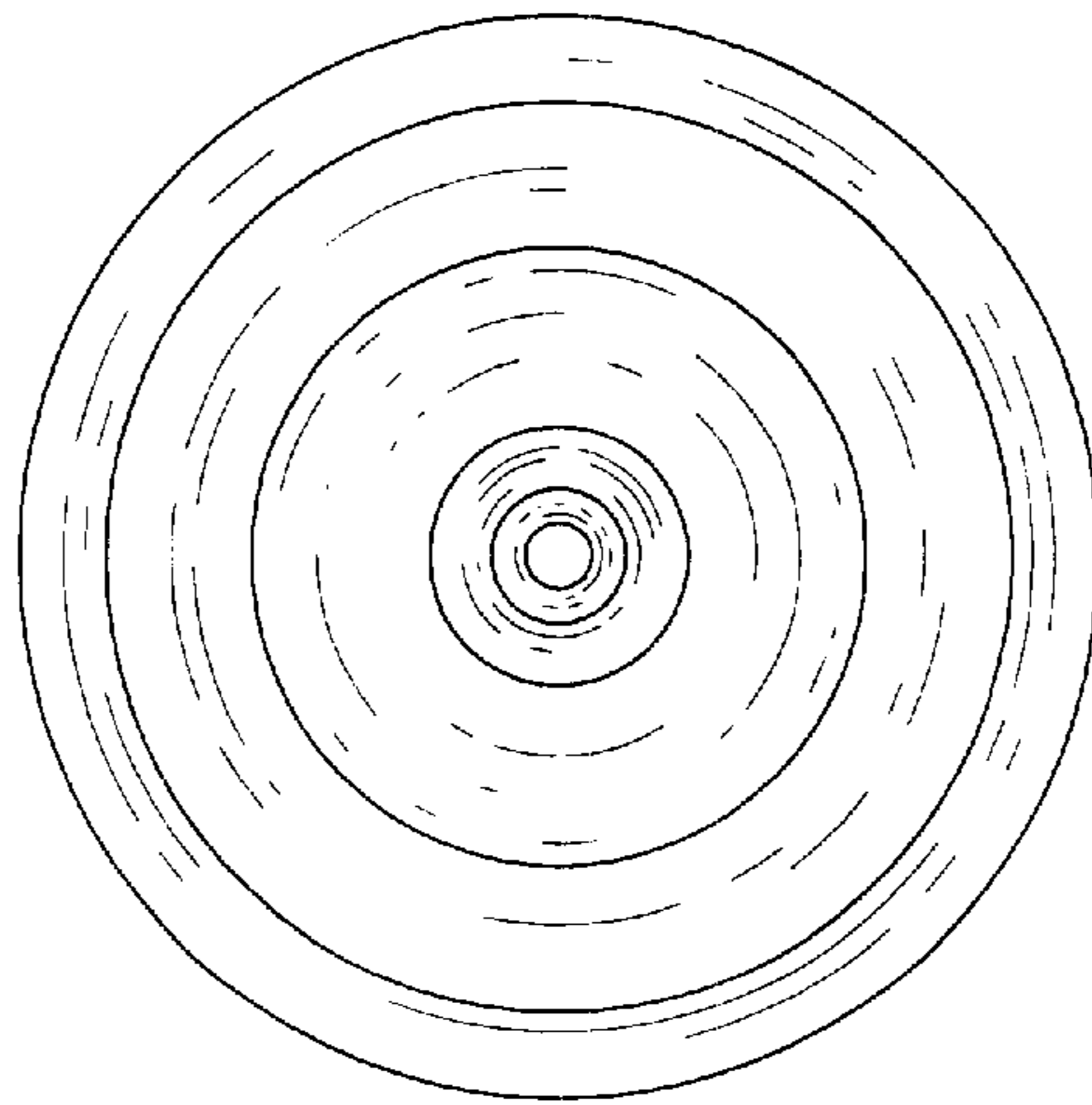




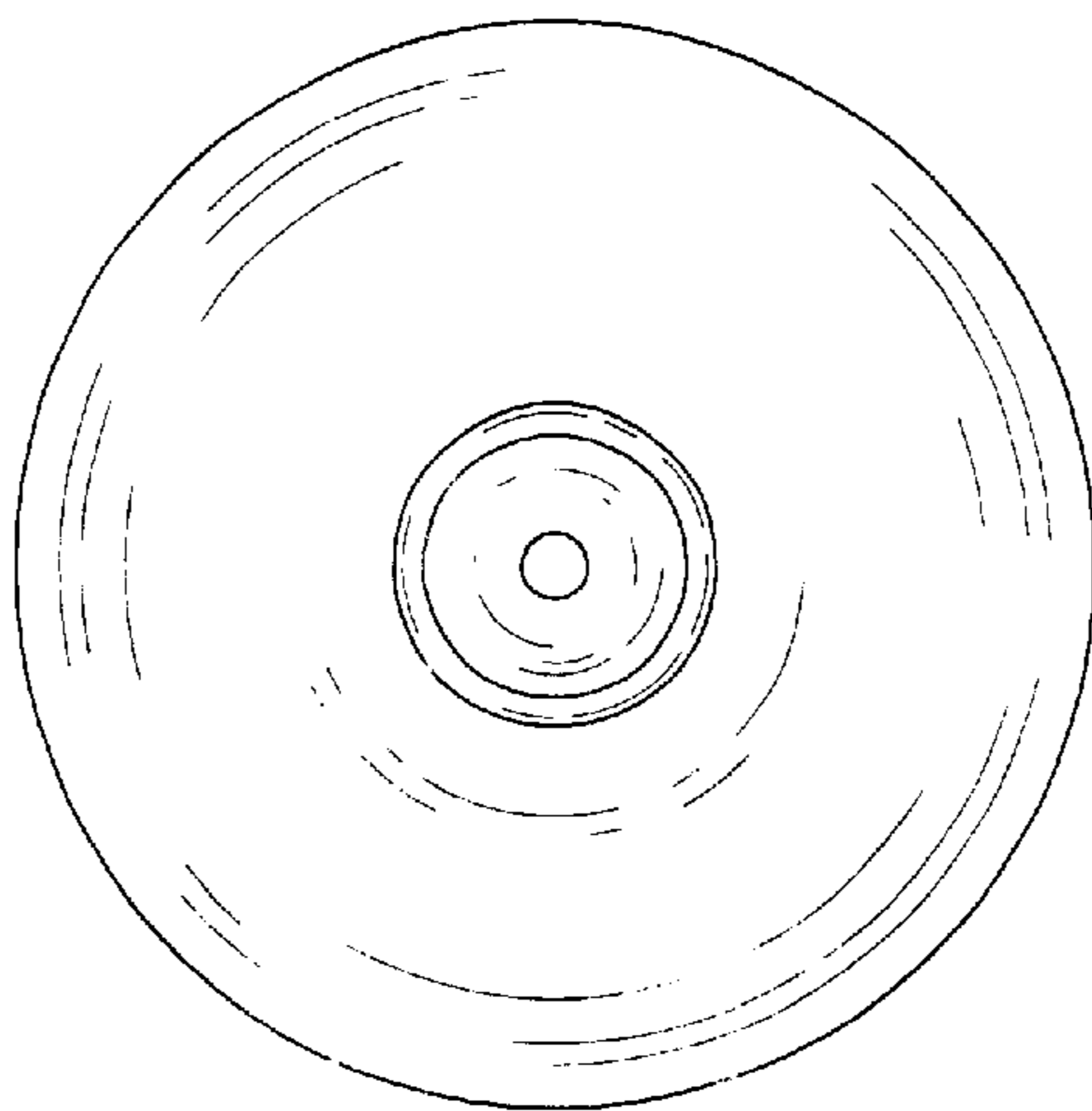
*Fig. 1*



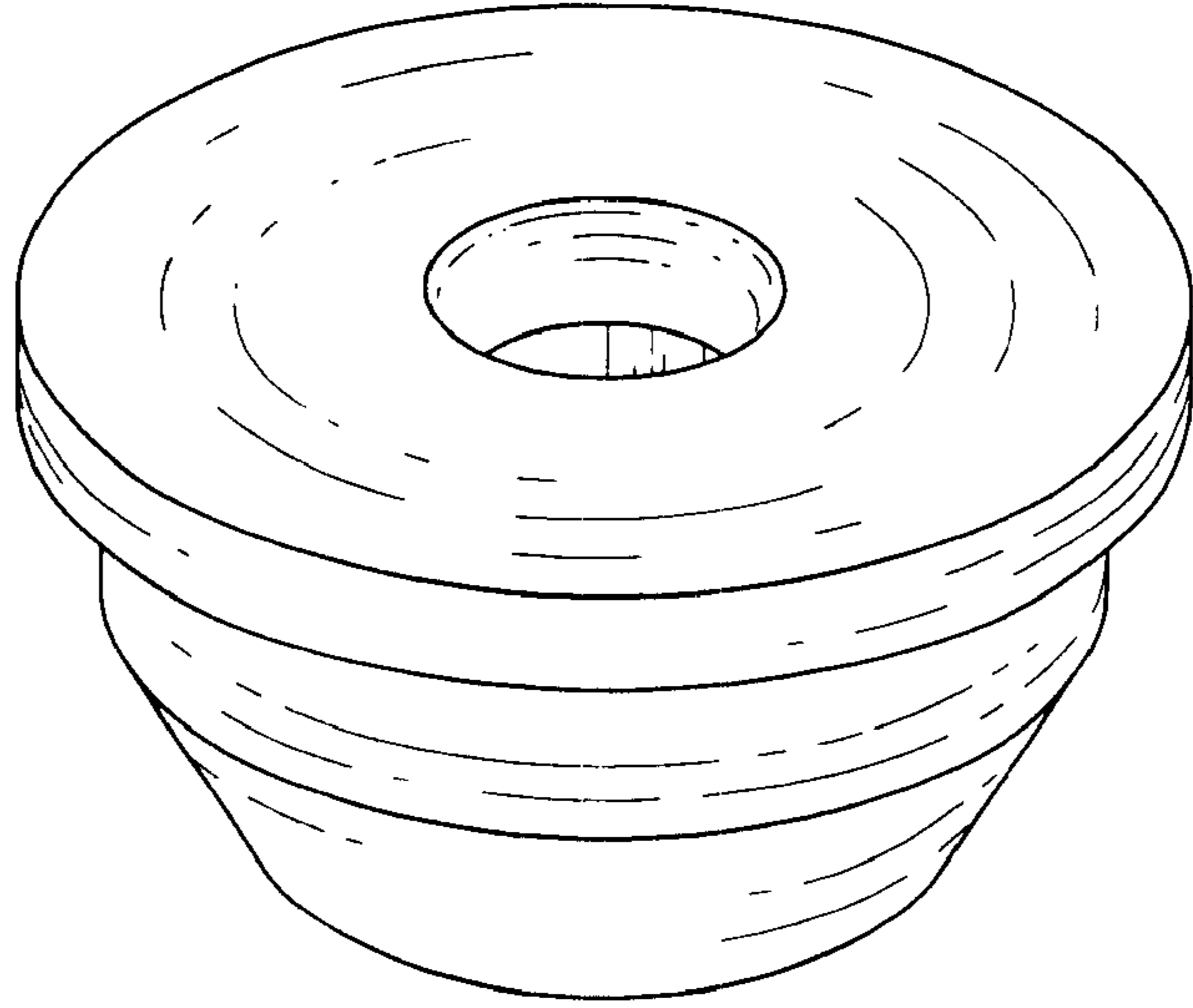
*Fig. 2*



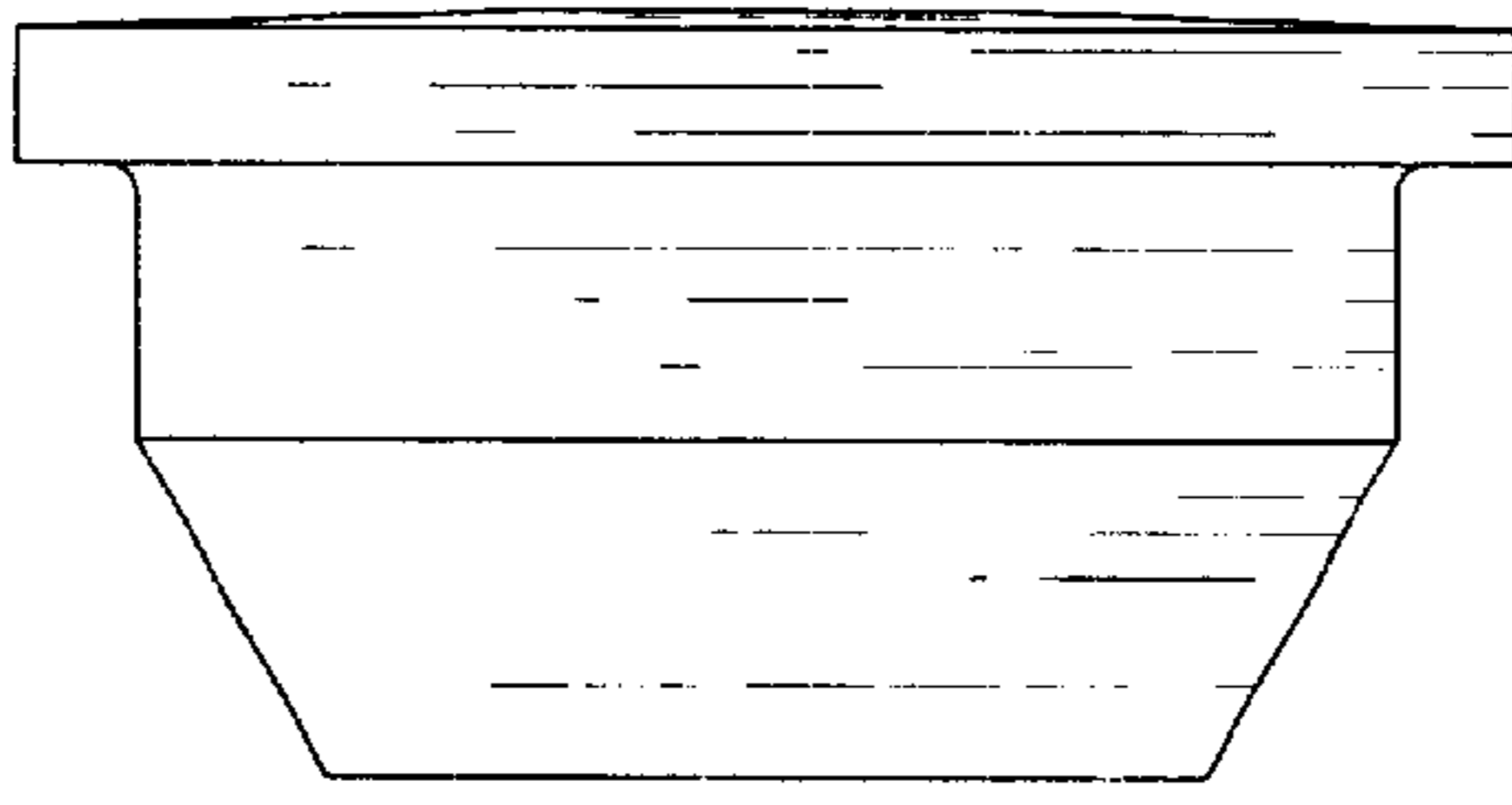
*Fig. 3*



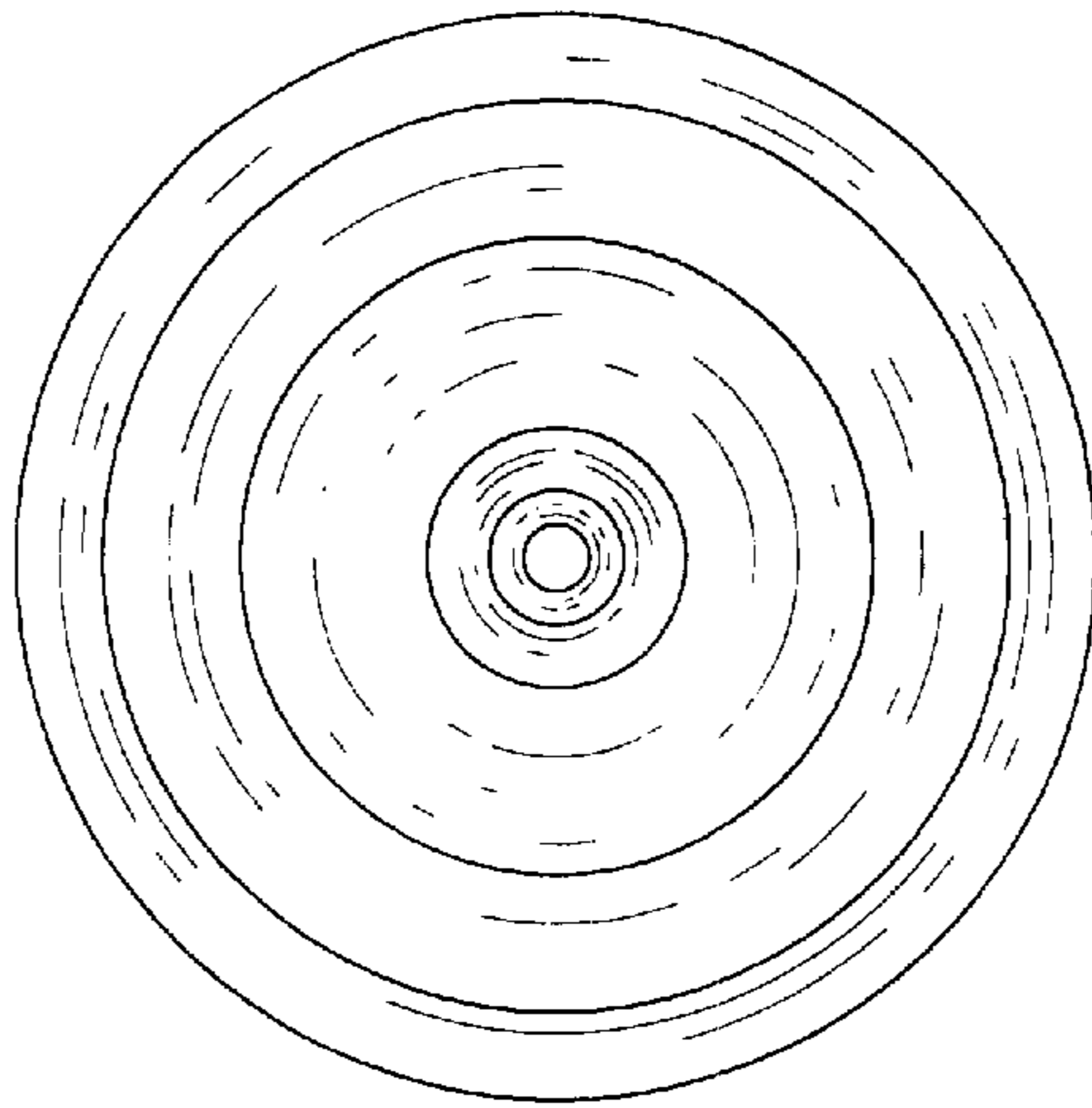
*Fig. 4*



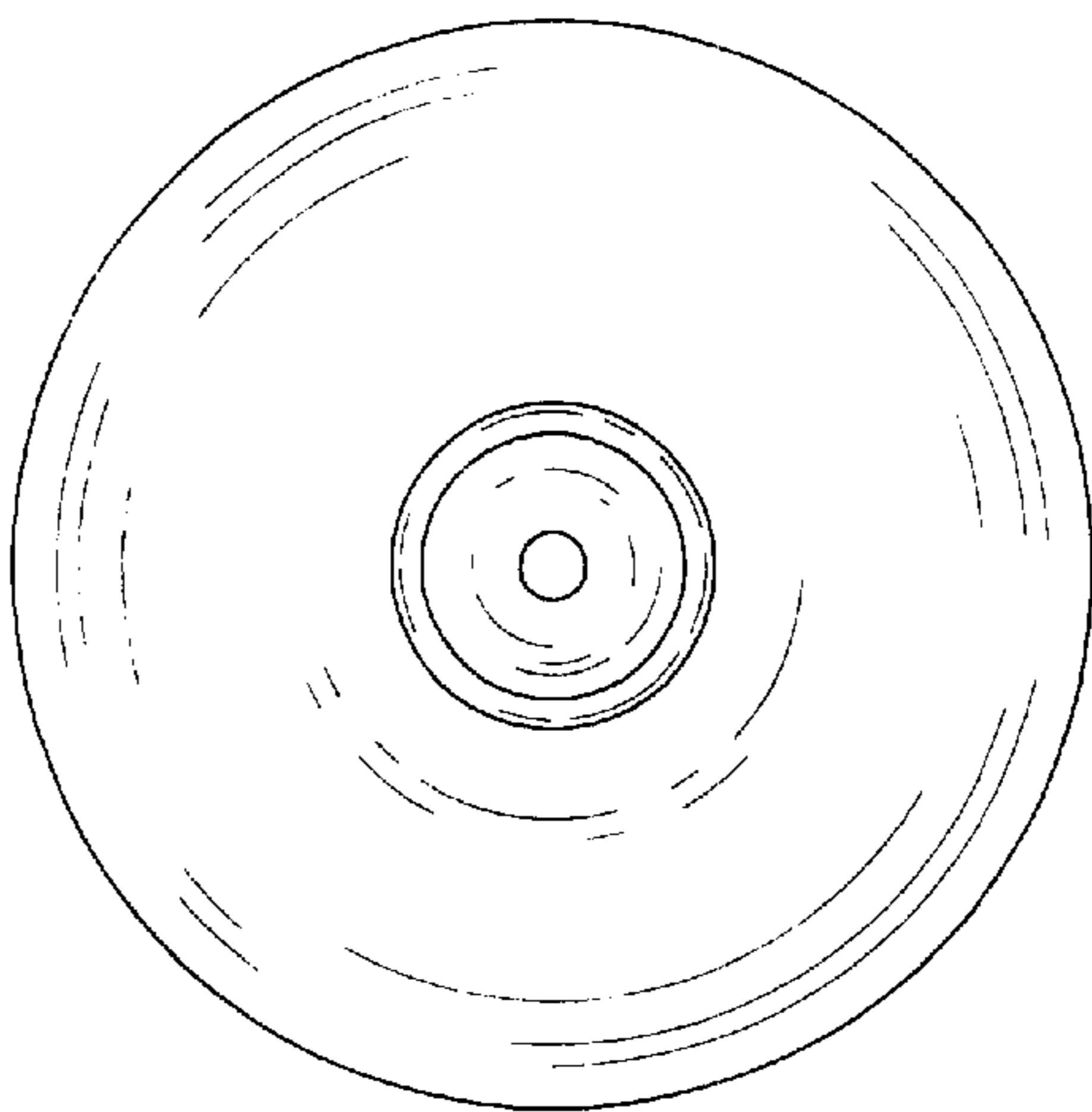
*Fig. 5*



*Fig. 6*



*Fig. 7*



*Fig. 8*