



US00D480744S

(12) **United States Design Patent**
Matsumura et al.

(10) **Patent No.:** **US D480,744 S**

(45) **Date of Patent:** **** Oct. 14, 2003**

(54) **SINGLE-LENS REFLEX CAMERA**
(75) Inventors: **Yoshiyuki Matsumura**, Yokosuka (JP);
Hiroshi Sano, Yokohama (JP);
Kenosuke Chujo, Tokyo (JP); **Hitoshi Takaono**, Tokyo (JP)

(73) Assignee: **Canon Kabushiki Kaisha**, Tokyo (JP)

(**) Term: **14 Years**

(21) Appl. No.: **29/170,183**

(22) Filed: **Nov. 4, 2002**

(30) **Foreign Application Priority Data**

May 7, 2002 (JP) 2002-011914

(51) **LOC (7) Cl.** **16-05**

(52) **U.S. Cl.** **D16/219; D16/217**

(58) **Field of Search** **D16/200-205,**
D16/208, 209, 216, 217, 218, 219; 396/175,
176, 354-359, 535-541

(56) **References Cited**

U.S. PATENT DOCUMENTS

D318,678 S * 7/1991 Tanaka et al. D16/217
5,253,003 A * 10/1993 Fujii et al. 396/175
D385,896 S * 11/1997 Matsuda D16/217

D418,530 S * 1/2000 Tanaka et al. D16/217
D433,435 S * 11/2000 Hamamura D16/219
D439,922 S * 4/2001 Kumakura D16/217
D471,222 S * 3/2003 Matsumura D16/217

* cited by examiner

Primary Examiner—Adir Aronovich

(74) *Attorney, Agent, or Firm*—Fitzpatrick, Cella, Harper & Scinto

(57) **CLAIM**

The ornamental design for a single-lens reflex camera, as shown and described.

DESCRIPTION

FIG. 1 is a front view of a single-lens reflex camera showing our new design;
FIG. 2 is a rear view thereof;
FIG. 3 is a top plan view thereof;
FIG. 4 is a bottom plan view thereof;
FIG. 5 is a left side view thereof;
FIG. 6 is a right side view thereof; and,
FIG. 7 is a perspective view thereof.

The portions of the article in broken lines are shown for illustrative purposes only and form no part of the claimed design. The chain-link broken lines define the bounds of the claimed design but form no part thereof.

1 Claim, 4 Drawing Sheets

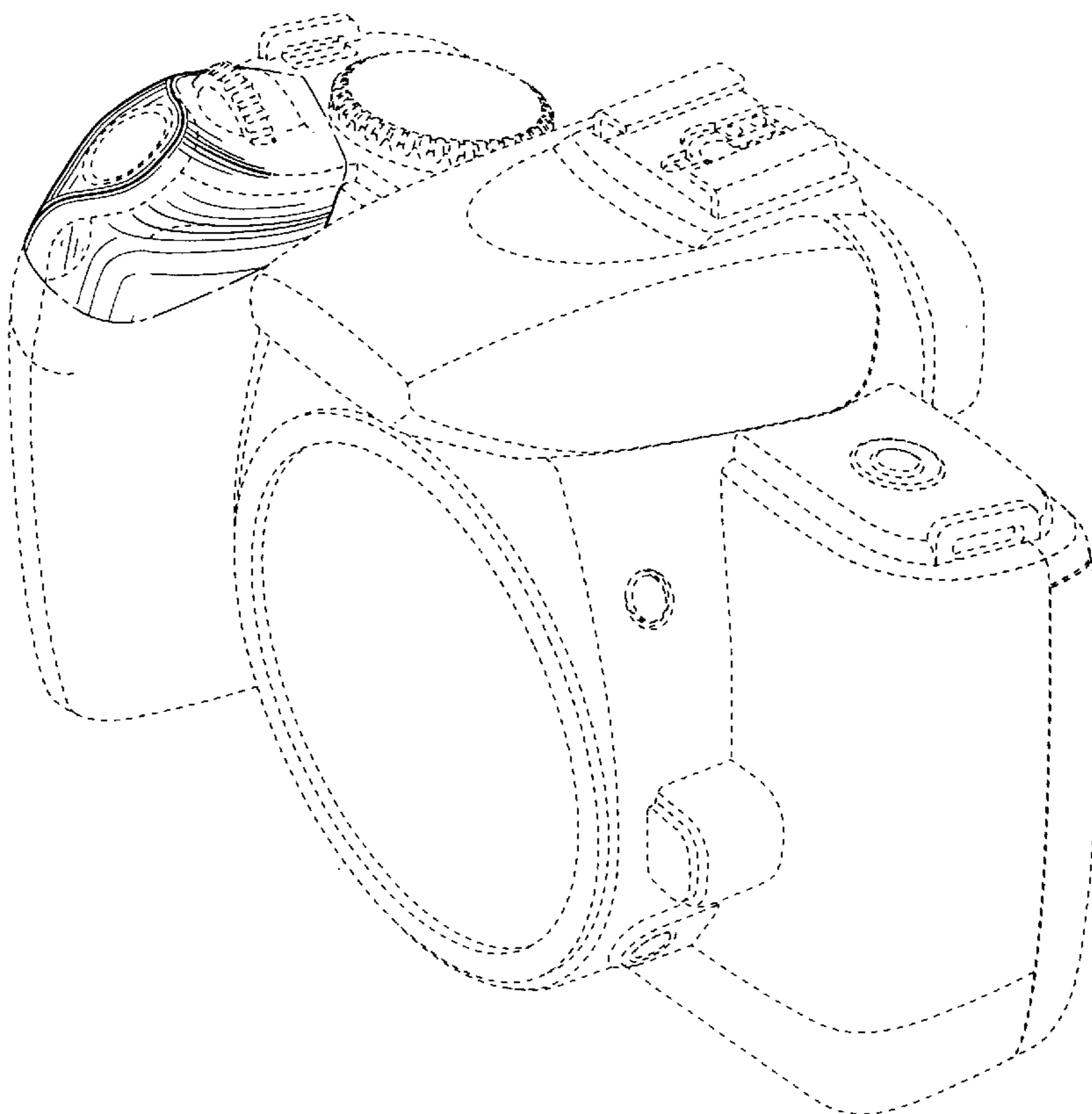

FIG. 1

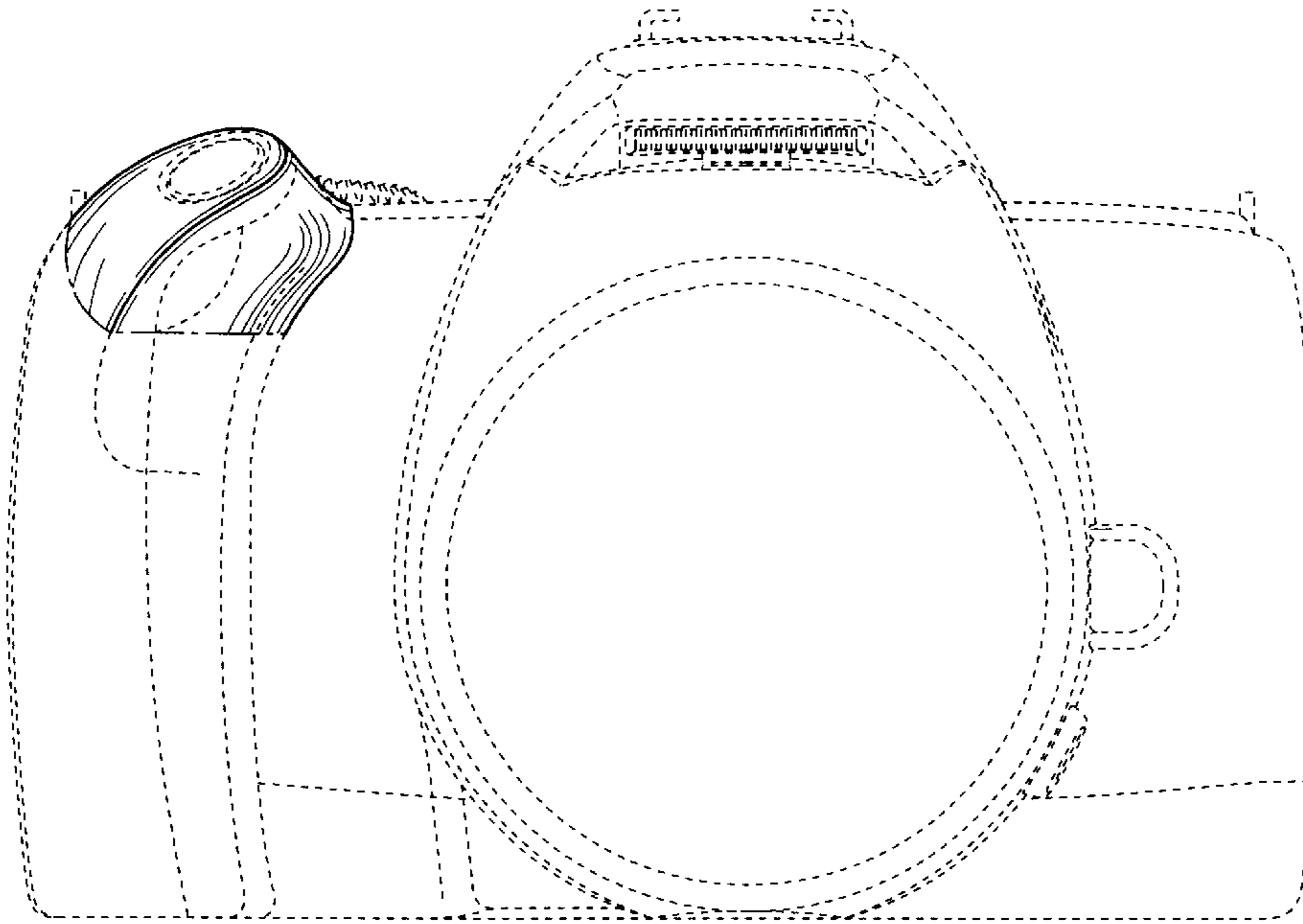

FIG. 2

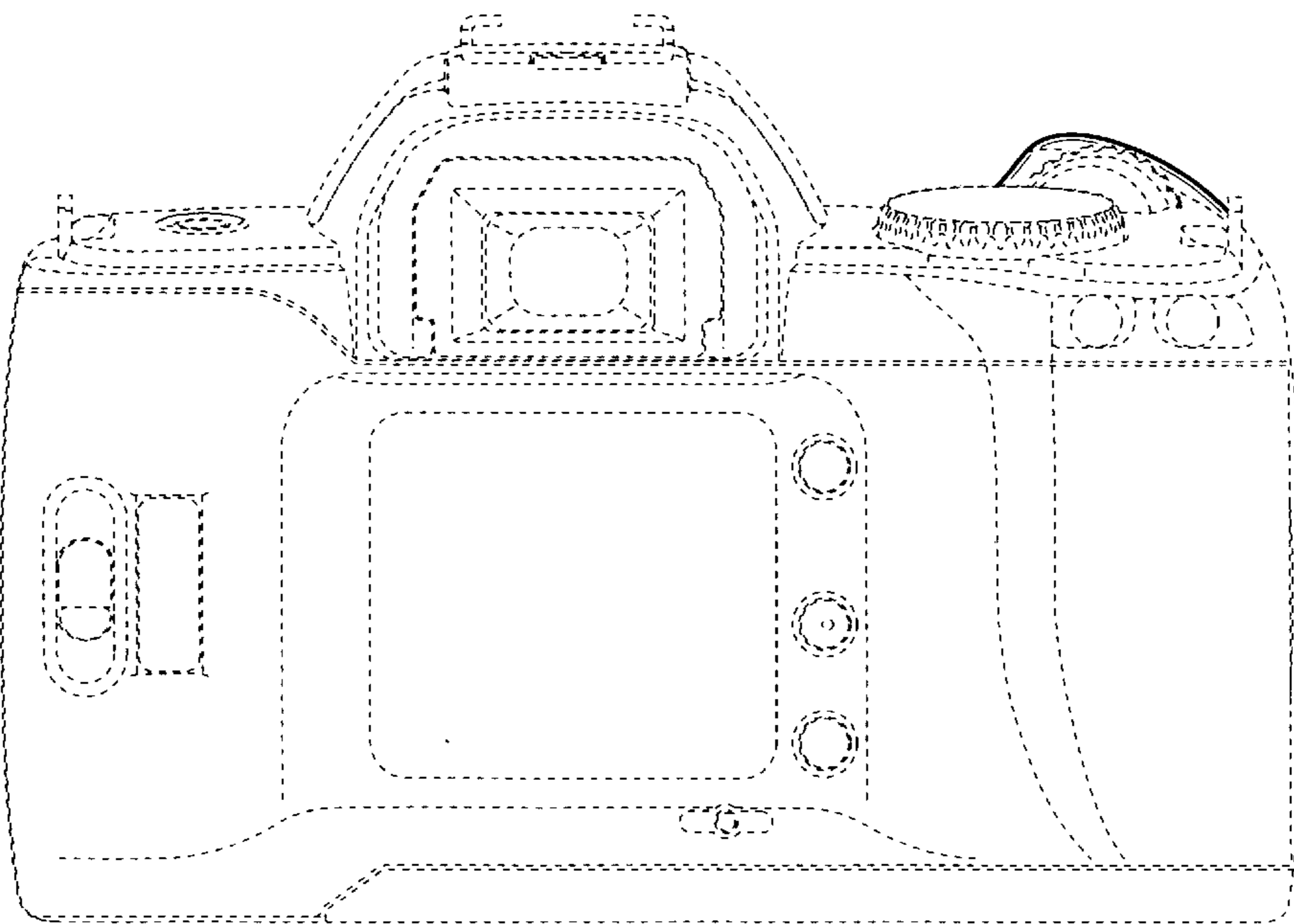

FIG. 3

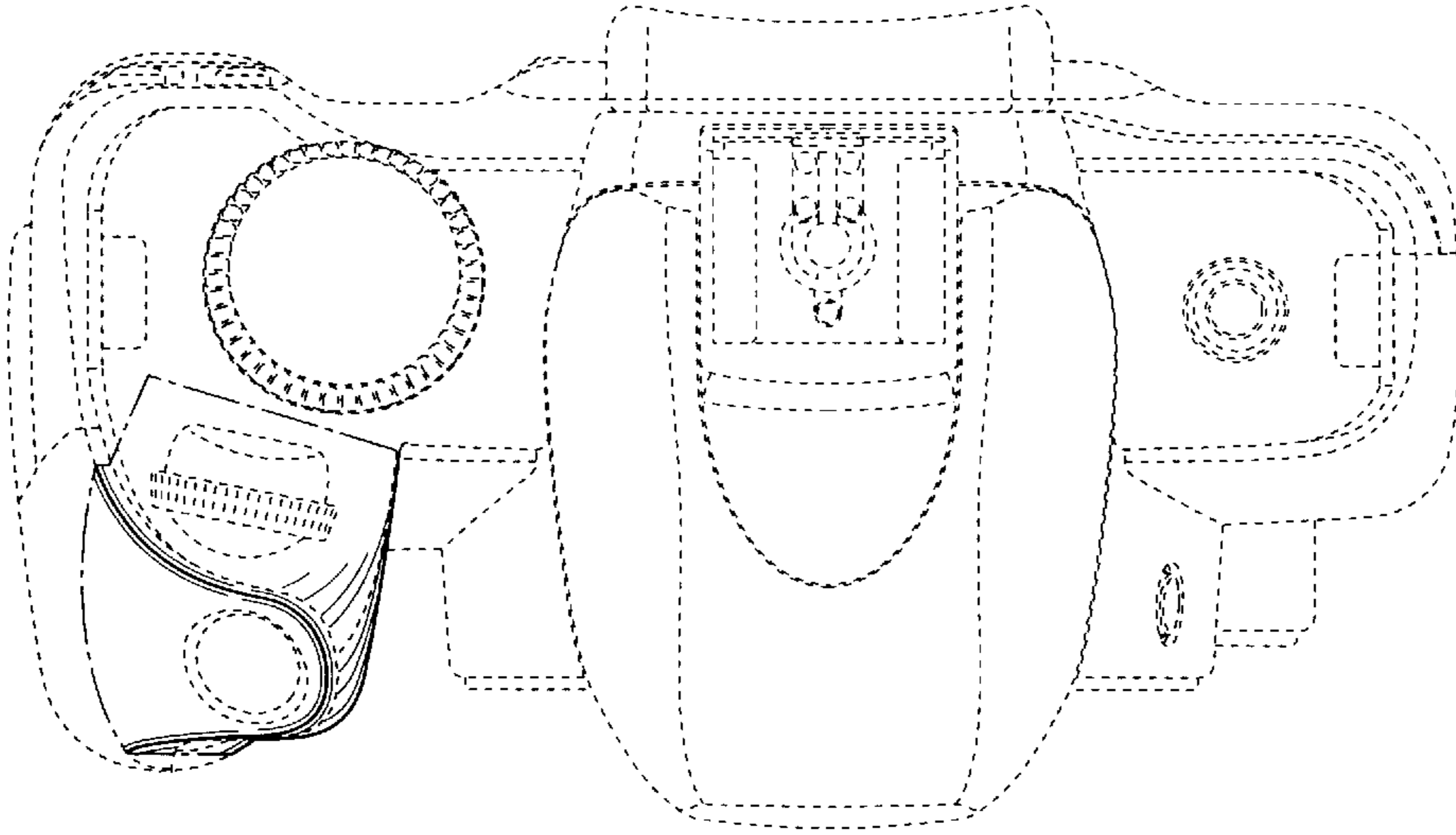

FIG. 4

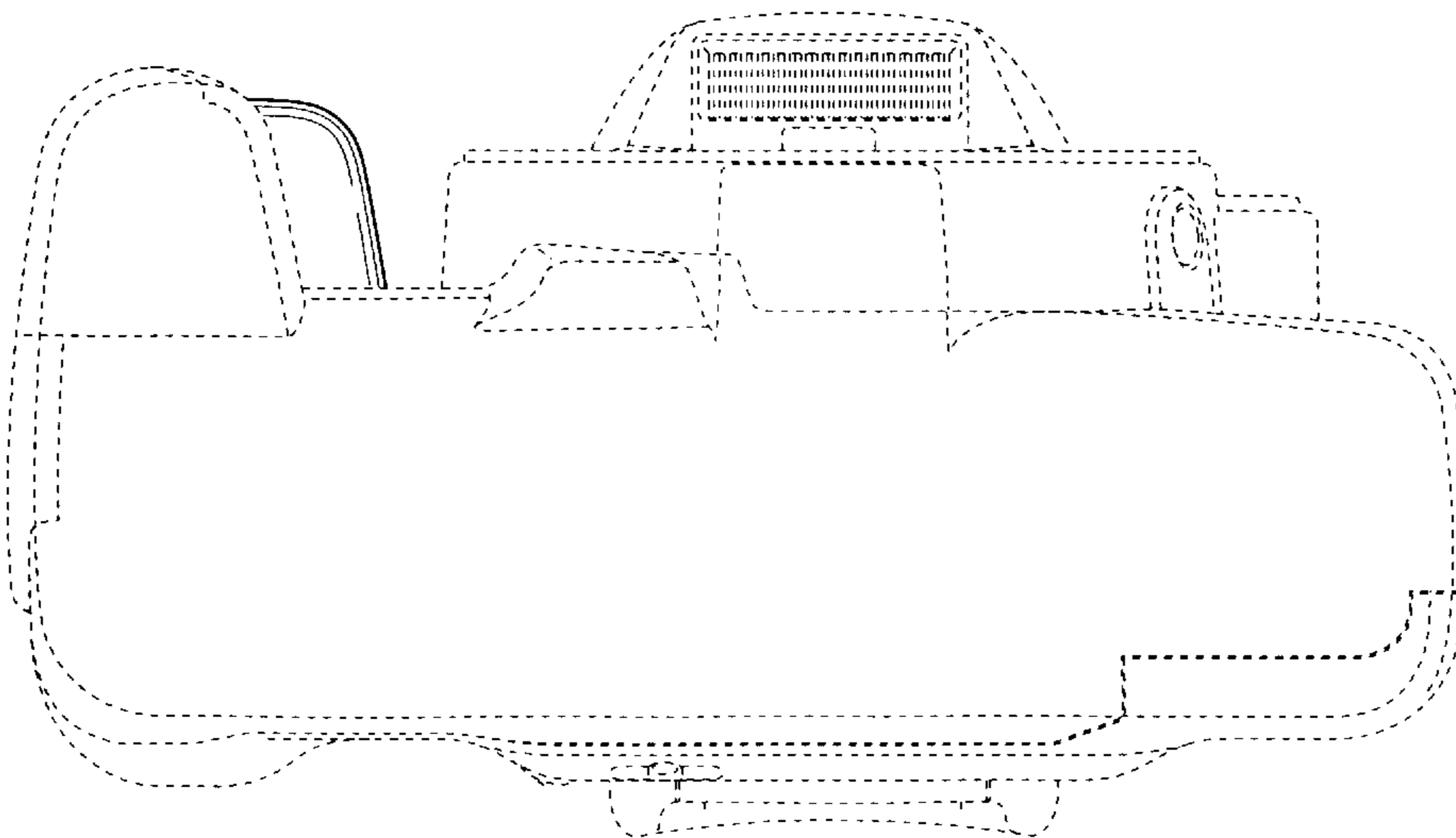

FIG. 5

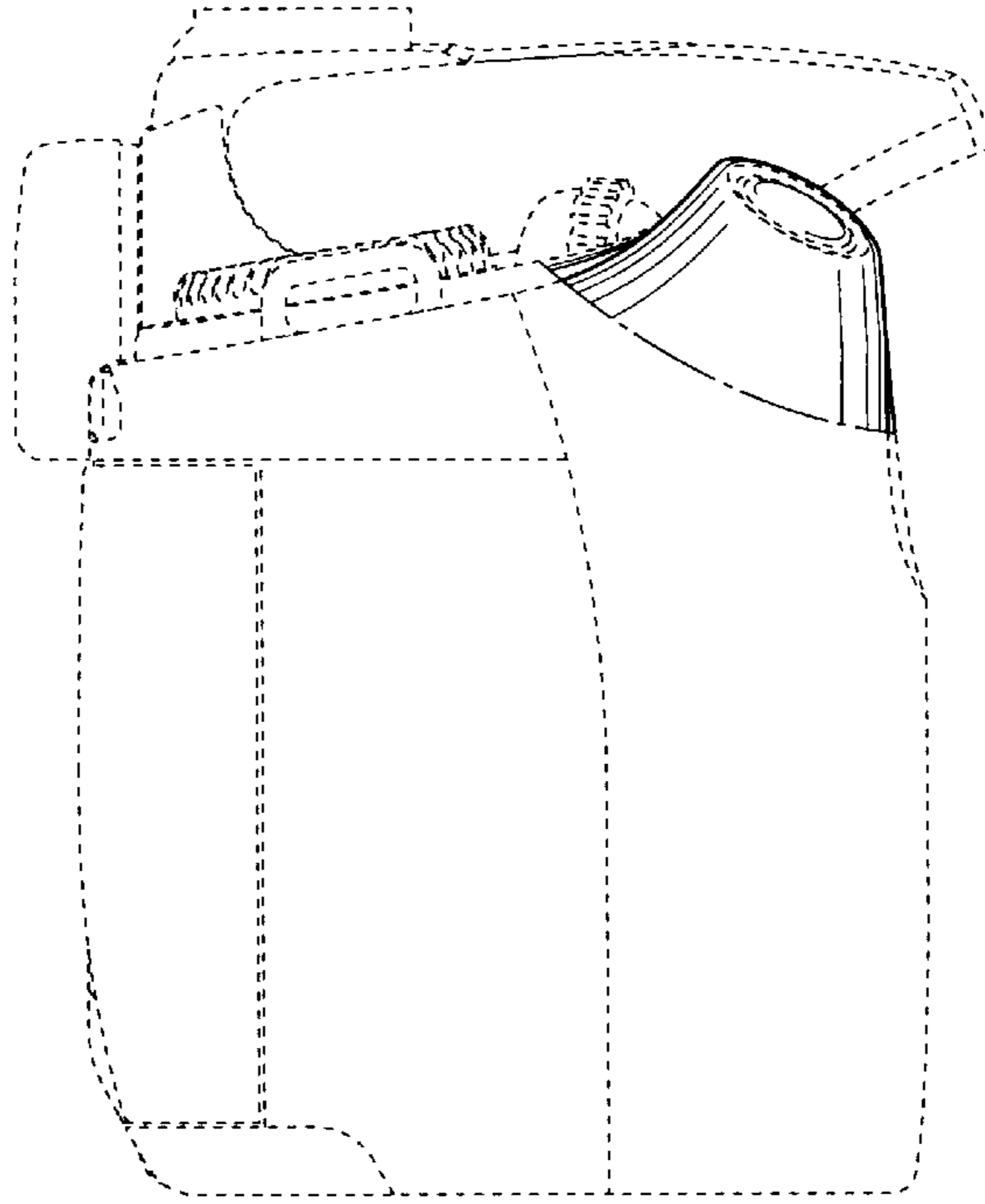

FIG. 6

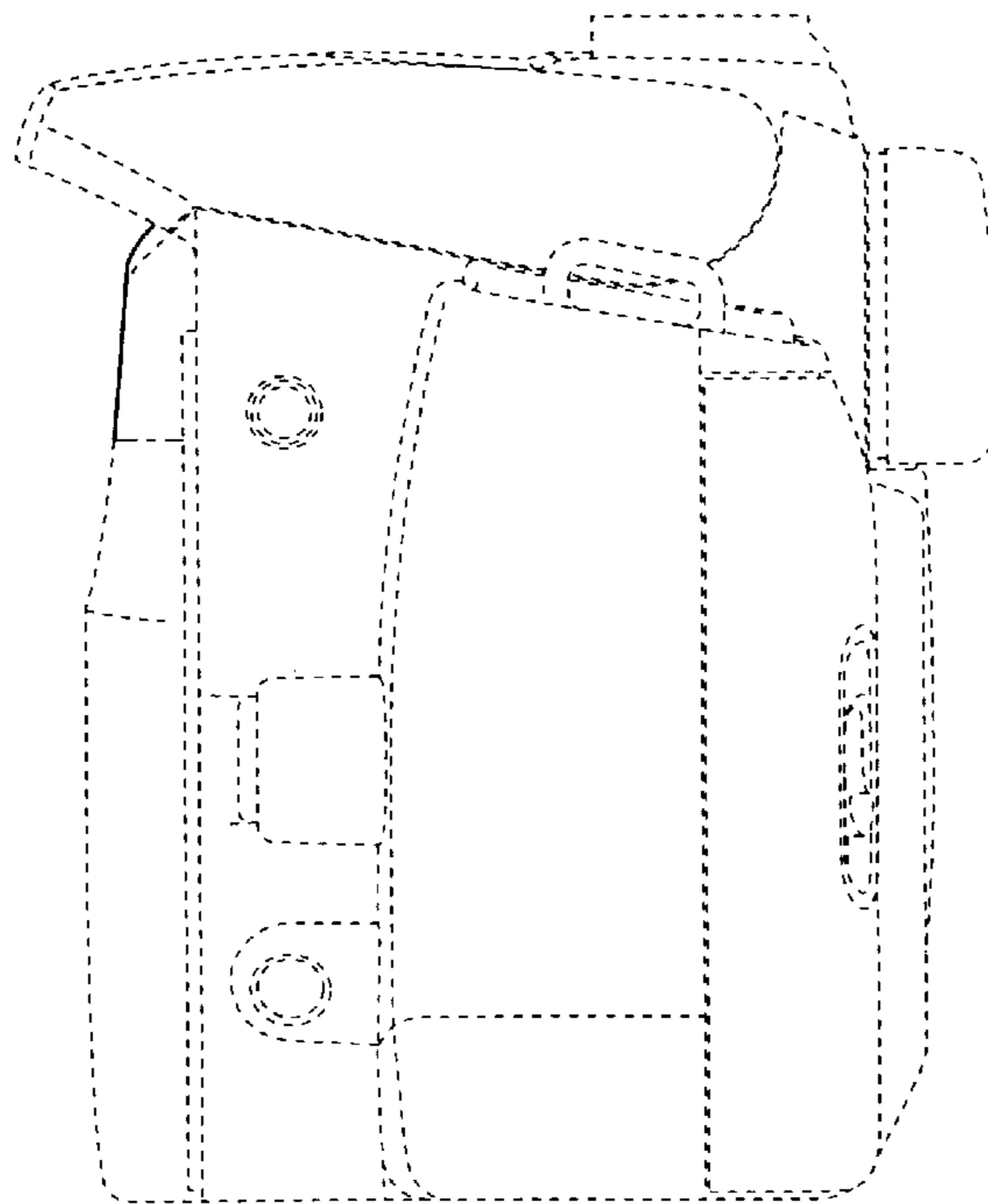

FIG. 7

