



US00D480579S

(12) **United States Design Patent**
Hillman

(10) **Patent No.:** **US D480,579 S**

(45) **Date of Patent:** **** Oct. 14, 2003**

(54) **MODULAR CD HOLDER**

(76) Inventor: **Glenn Hillman**, 31 Elm St., Apt. D,
Westfield, NJ (US) 07090

(**) Term: **14 Years**

(21) Appl. No.: **29/159,463**

(22) Filed: **Apr. 22, 2002**

(51) **LOC (7) Cl.** **06-04**

(52) **U.S. Cl.** **D6/407**

(58) **Field of Search** D6/407, 627-630,
D6/449, 310-312; 206/308.1, 309; 211/40,
42, 43, 41.12; 248/454, 456, 441.1, 463,
473; 312/9.1, 9.9, 9.11, 9.16, 9.46, 9.47,
9.51, 9.54, 9.64, 9.53

(56) **References Cited**

U.S. PATENT DOCUMENTS

D211,187 S	*	5/1968	Florane	D6/407
D211,188 S	*	5/1968	Florane	D6/407
4,928,818 A	*	5/1990	Friess et al.	206/309
5,603,415 A	*	2/1997	Balnis, Jr.	211/40
D416,706 S	*	11/1999	Johnson, Jr.	D6/407
D468,147 S	*	1/2003	Werner	D6/629
D468,934 S	*	1/2003	Dienstmann	D6/449
D470,000 S	*	2/2003	Hillman	D6/629

OTHER PUBLICATIONS

http://www.bludot.com/productpics/pib_2D3DWMCD_blue.gif; Wall Mount CD Rack; Design & Manufacturing Inc., 3306 5th Street, N.E., Minneapolis, MN 55418; Apr. 21, 2002.

http://www.bludot.com/productpics/pib_2D3D4SCD_green.gif; 4 Squared CD Rack; Design & Manufacturing Inc., 3306 5th Street, N.E., Minneapolis, MN 55418; Apr. 21, 2002.

<http://www.offi.com/prods/pix/3/2/05.jpg>; CD Tower; Offi & Company, 5850 Hollis Street, Emeryville, PA 94608; Apr. 21, 2002.

* cited by examiner

Primary Examiner—Cathron C. Brooks
(74) *Attorney, Agent, or Firm*—Lerner, David, Littenberg, Krumholz & Mentlik, LLP

(57) **CLAIM**

The ornamental design for a modular CD holder, as shown and described.

DESCRIPTION

FIG. 1 is a perspective view looking from above of a modular CD holder showing my new design;
FIG. 2 is a front elevational view thereof;
FIG. 3 is a rear elevational view thereof;
FIG. 4 is a left side elevational view thereof;
FIG. 5 is a right side elevational view thereof;
FIG. 6 is a top plan view thereof; and,
FIG. 7 is a bottom plan view thereof.

1 Claim, 3 Drawing Sheets

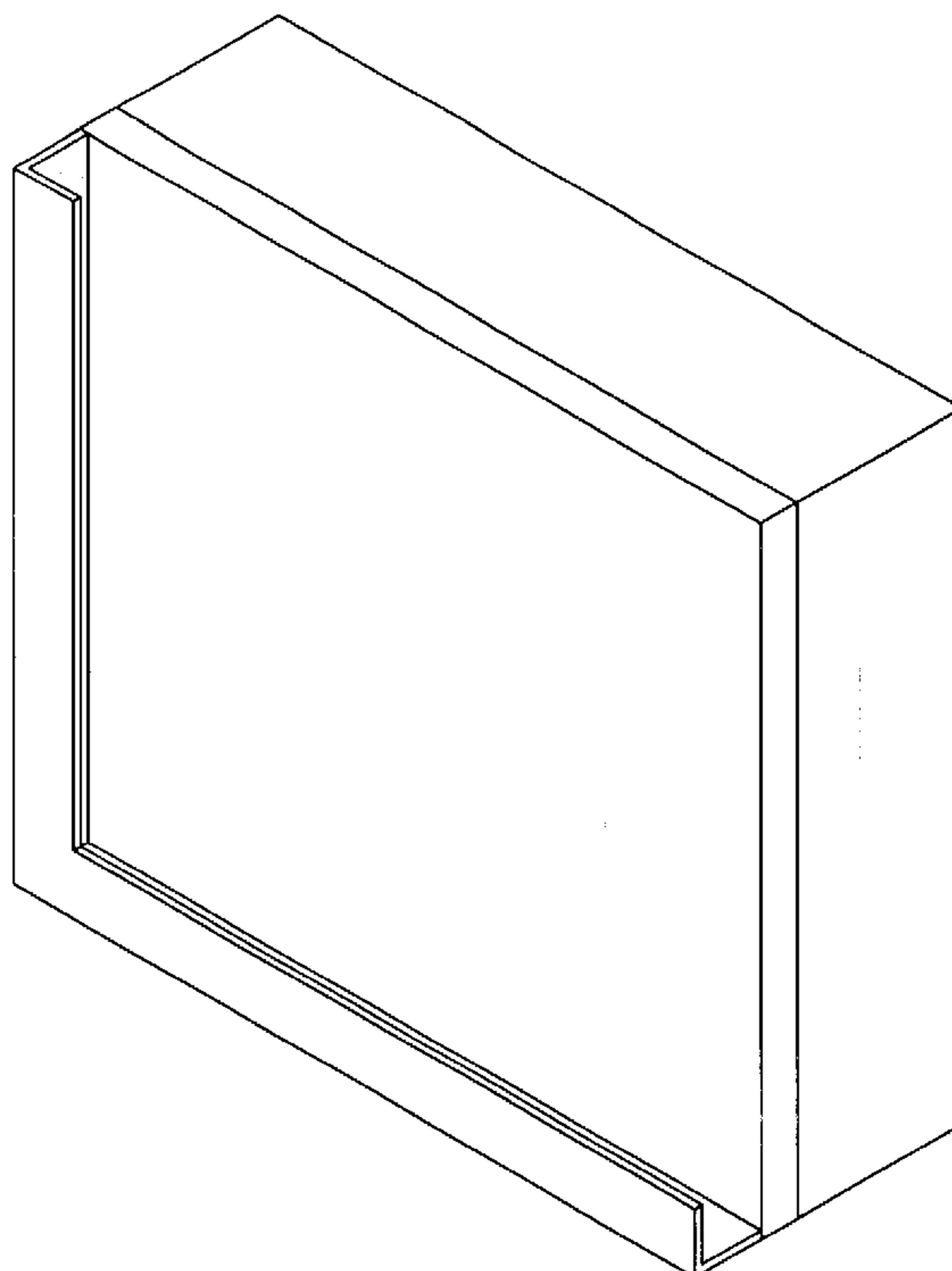

FIG. 1

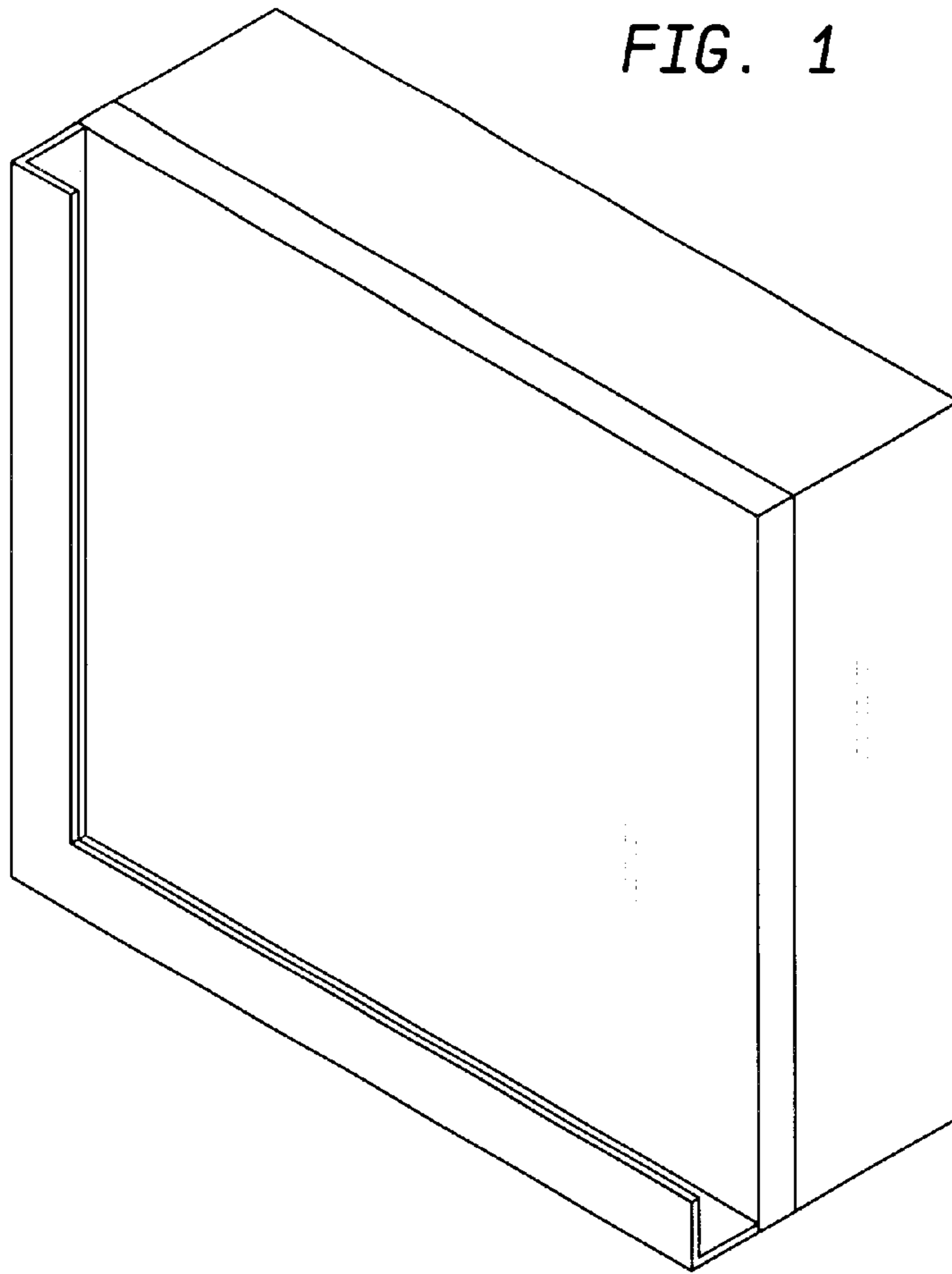

FIG. 2

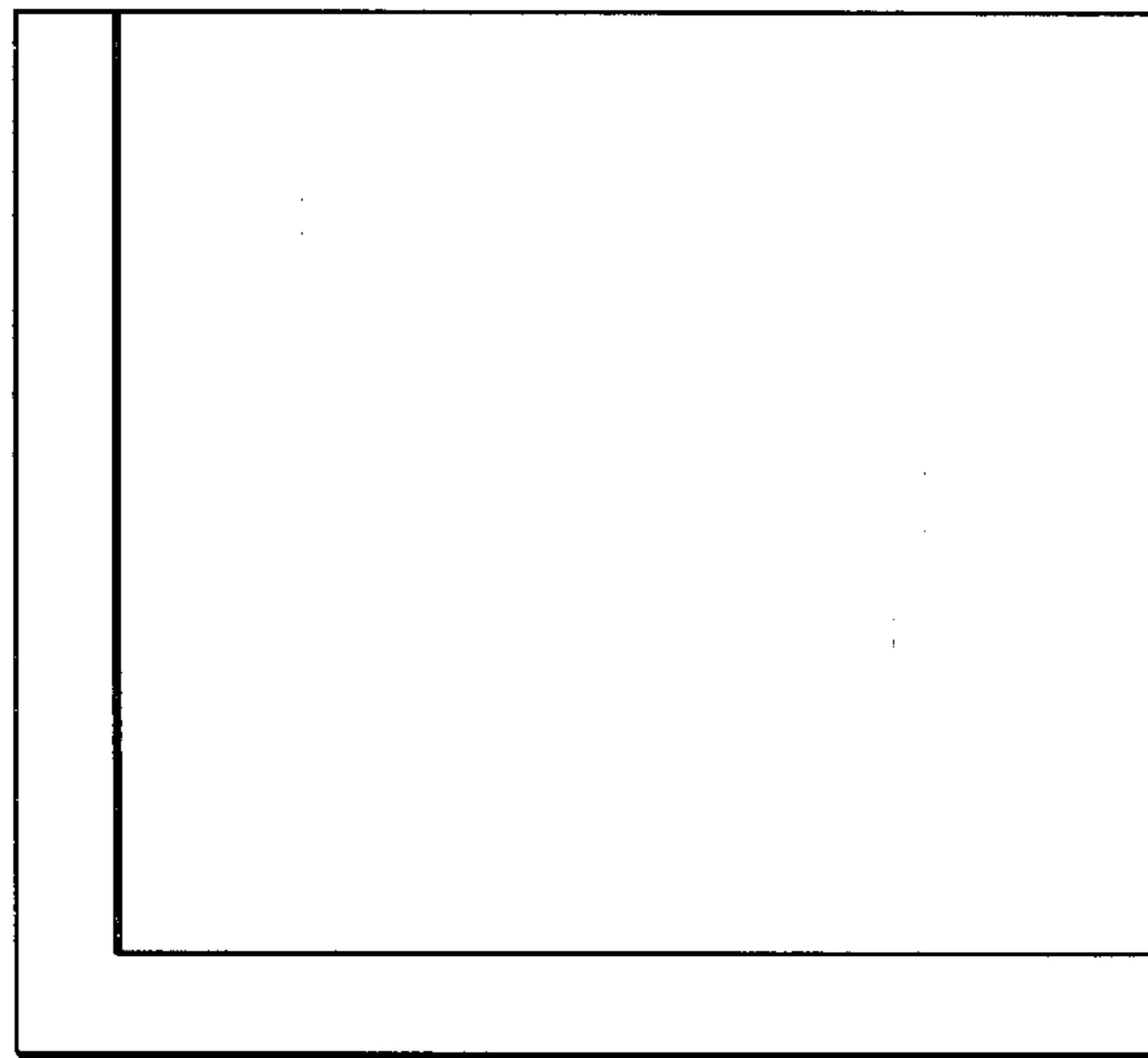

FIG. 3

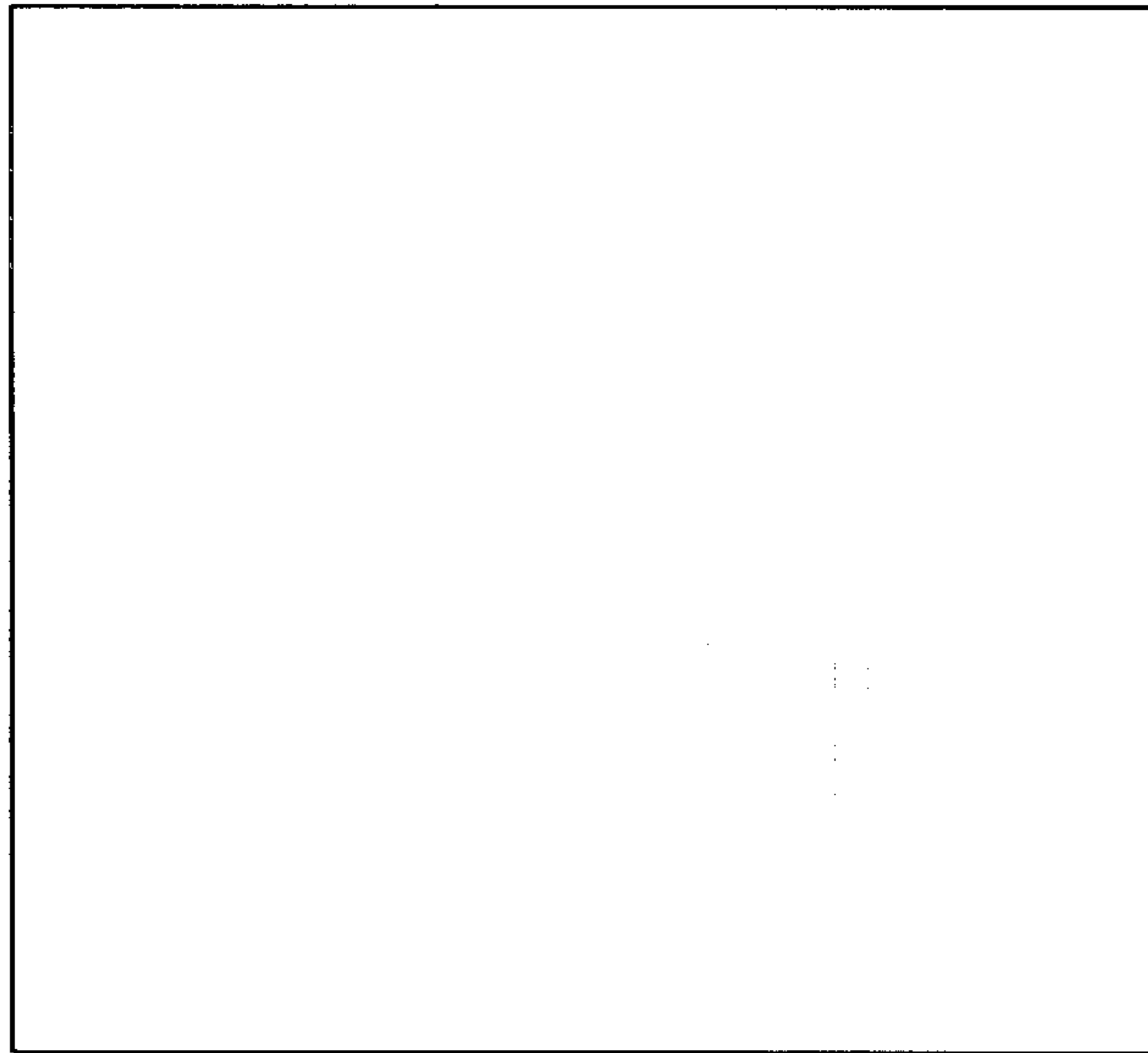

FIG. 4

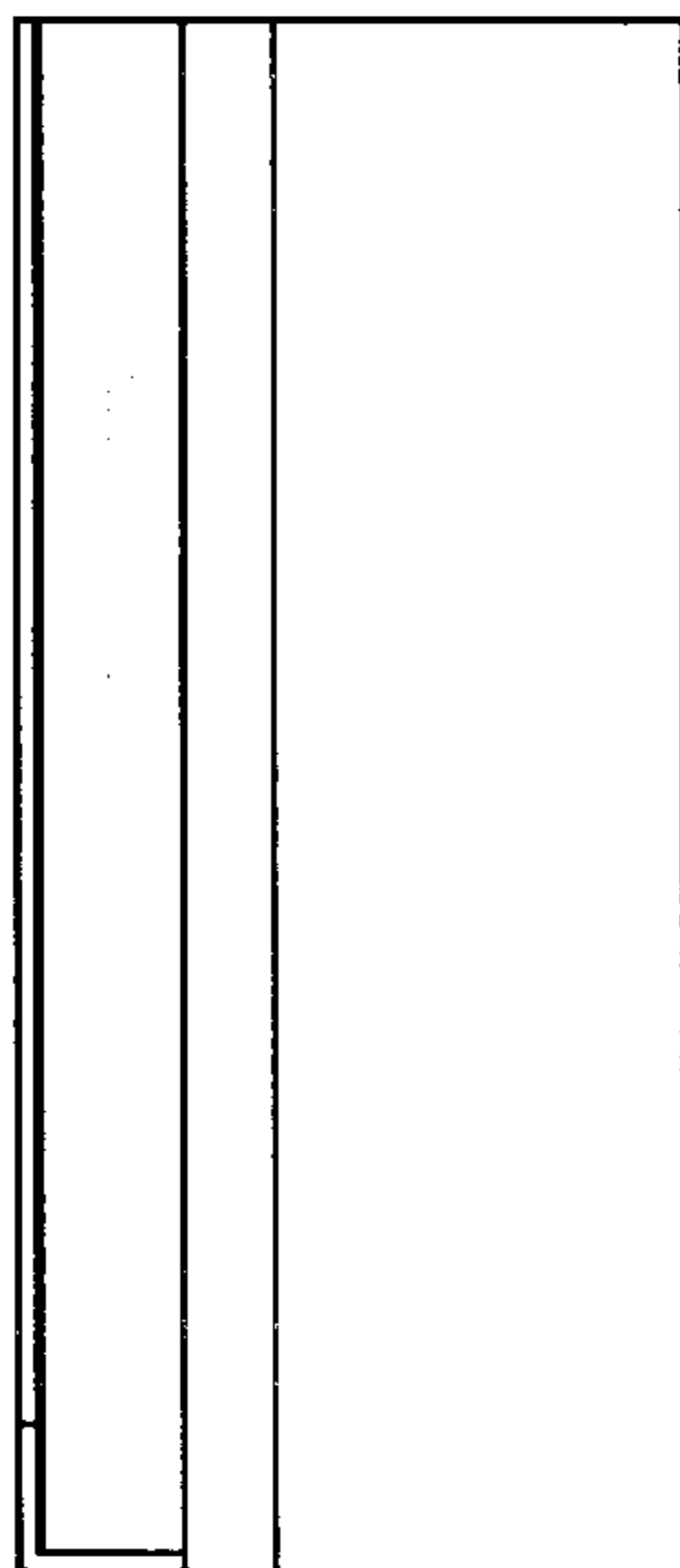

FIG. 5

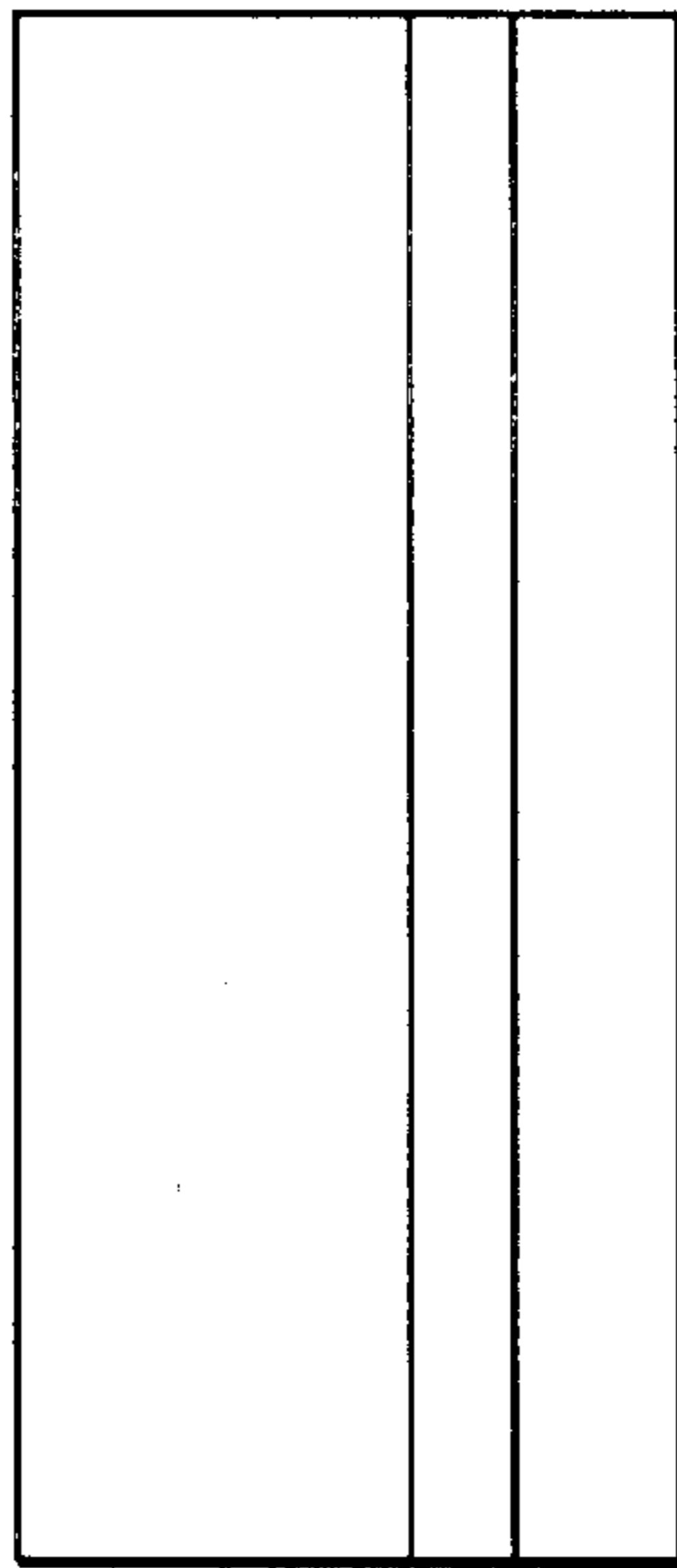

FIG. 6

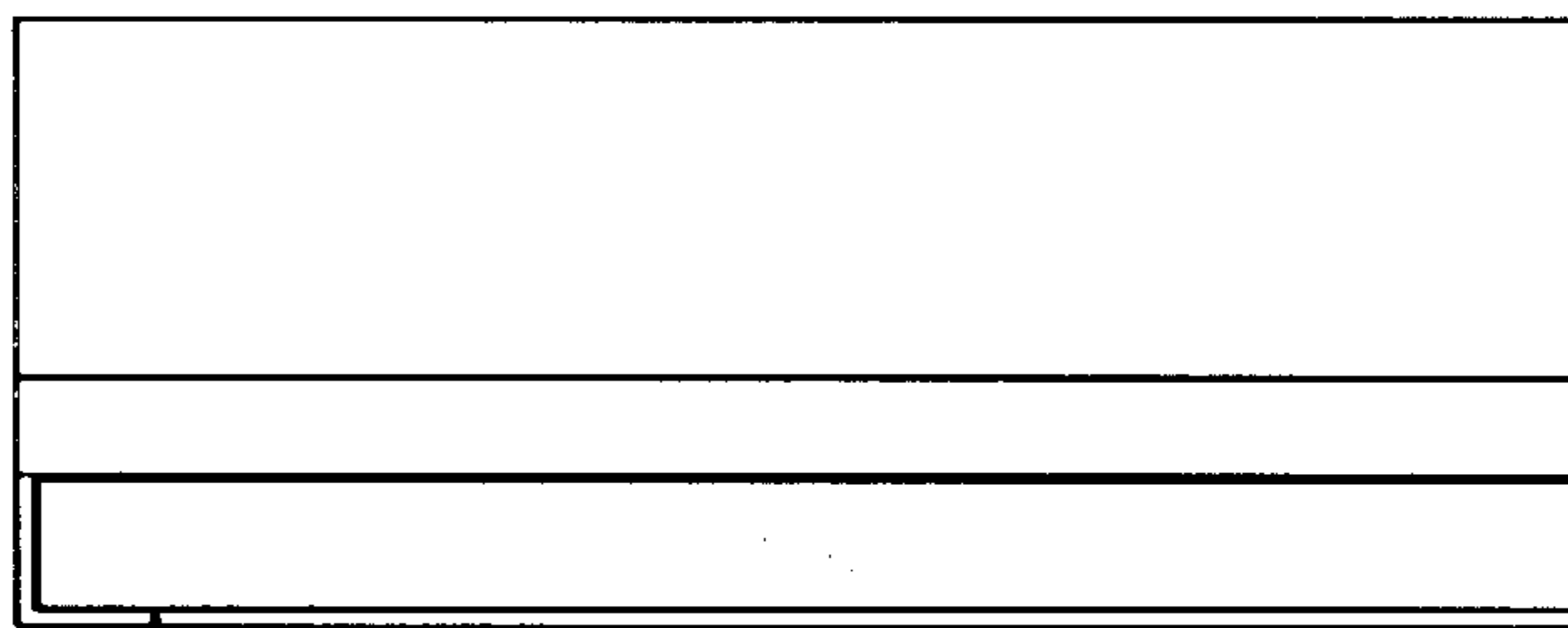

FIG. 7

