



US00D480535S

(12) **United States Design Patent**
Hammond

(10) **Patent No.:** **US D480,535 S**

(45) **Date of Patent:** **** Oct. 14, 2003**

(54) **PASSENGER HOLD ONTO SAFETY BELT**

D457,688 S * 5/2002 Cordero D2/627 X

(76) **Inventor:** **Samuel E. Hammond**, 2564 Twin Woods Cove, Memphis, TN (US) 38134

* cited by examiner

Primary Examiner—Paula A. Mortimer

(**) **Term:** **14 Years**

(57) **CLAIM**

(21) **Appl. No.:** **29/165,547**

The ornamental design for a passenger hold onto safety belt, as shown and described.

(22) **Filed:** **Aug. 13, 2002**

DESCRIPTION

(51) **LOC (7) Cl.** **02-07**

(52) **U.S. Cl.** **D2/627**

(58) **Field of Search** D2/627, 629; D29/100; 2/300, 311, 312, 321, 305; 224/660

FIG. 1 is a front elevational view of a passenger hold onto safety belt showing my new design, the belt is drawn broken away to show indeterminate length;

FIG. 2 is an inner side view of the passenger hold onto safety belt;

FIG. 3 is a first end edge view of the passenger hold onto safety belt;

FIG. 4 is a second end edge view of the passenger hold onto safety belt;

FIG. 5 is a side edge view of the passenger hold onto safety belt; and,

FIG. 6 is a perspective view of the passenger hold onto safety belt.

(56) **References Cited**

U.S. PATENT DOCUMENTS

2,661,888	A	*	12/1953	Sidlinger	D2/627
3,896,499	A	*	7/1975	Kelly	2/311
3,940,801	A	*	3/1976	Riggs et al.	2/311
4,028,742	A	*	6/1977	Marquis	2/305
4,411,222	A	*	10/1983	Wolfson	2/300
4,413,358	A	*	11/1983	Jimenez	2/321
5,081,719	A	*	1/1992	Donnelly	2/311

1 Claim, 2 Drawing Sheets

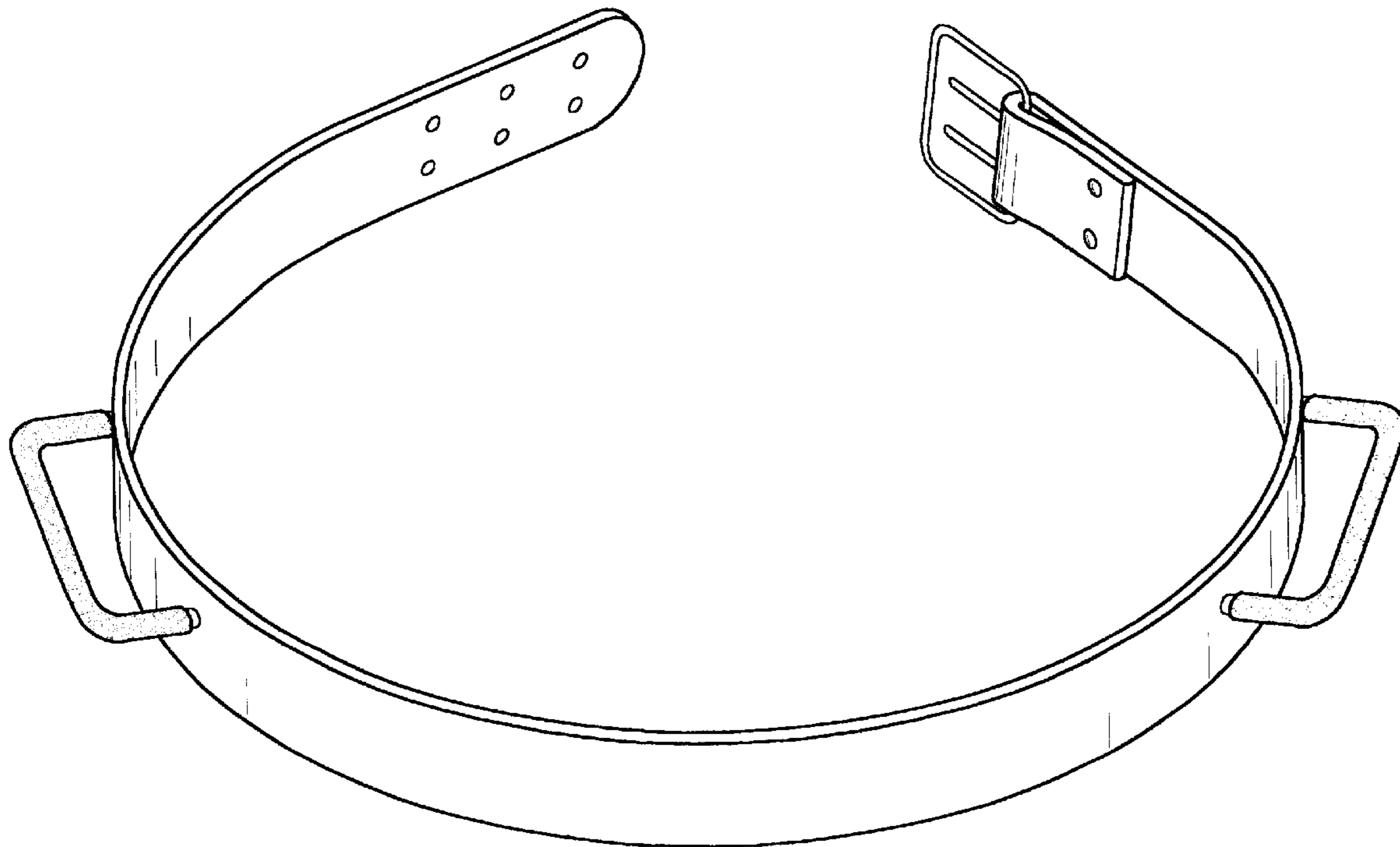

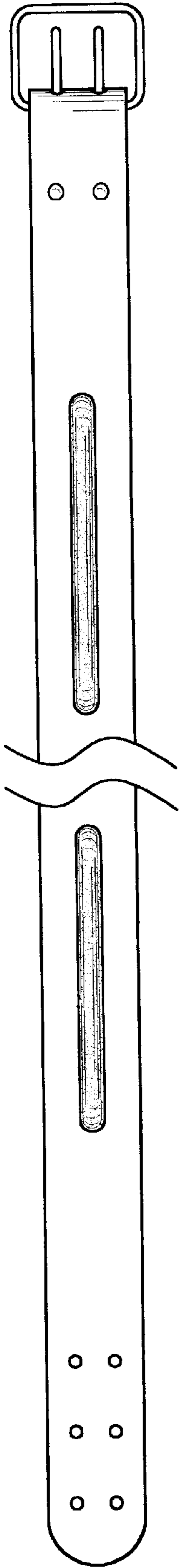

FIG. 1

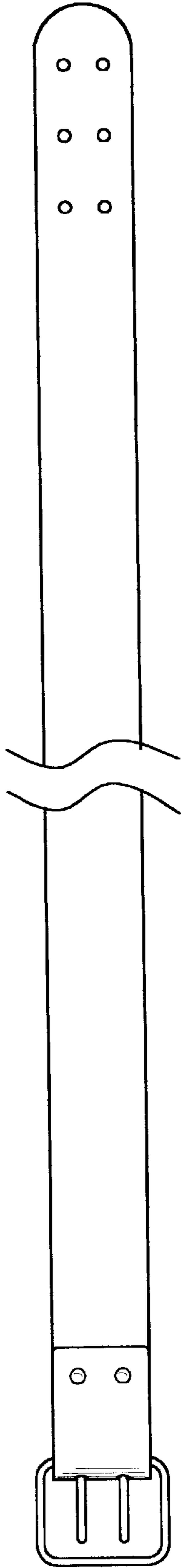

FIG. 2

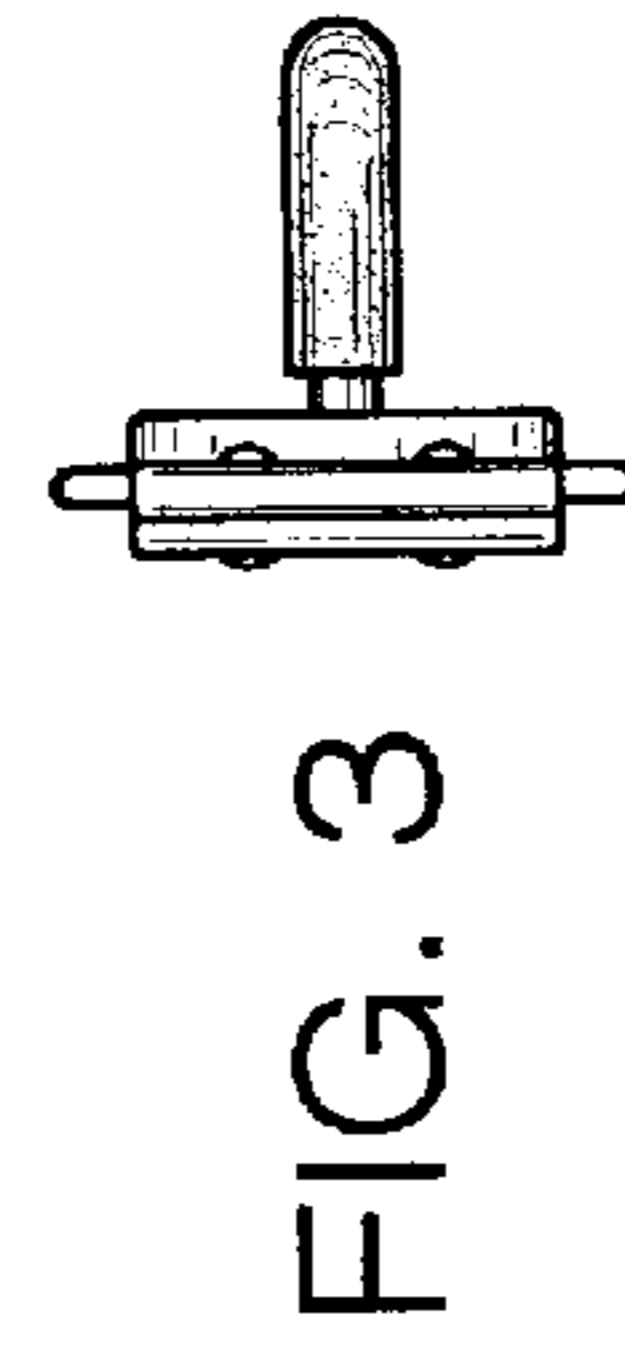

FIG. 3

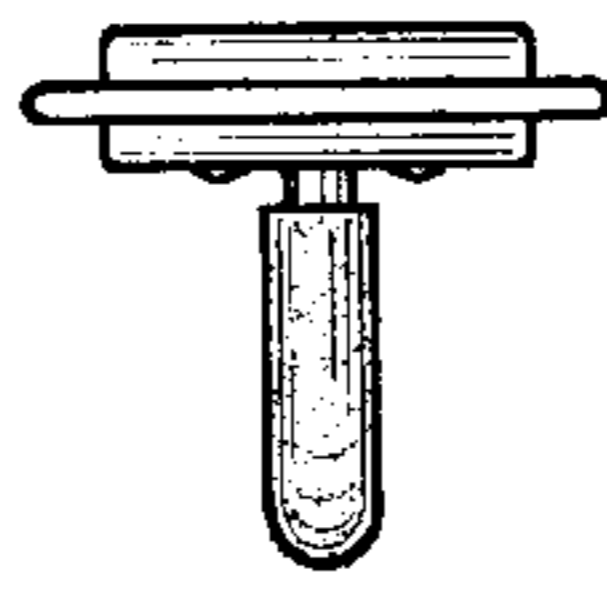

FIG. 4

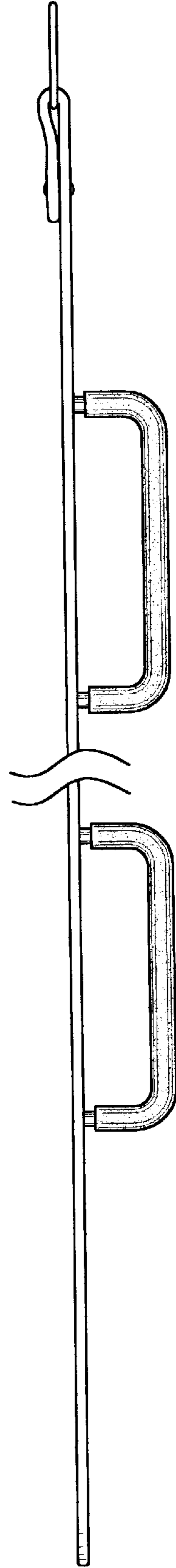

FIG. 5

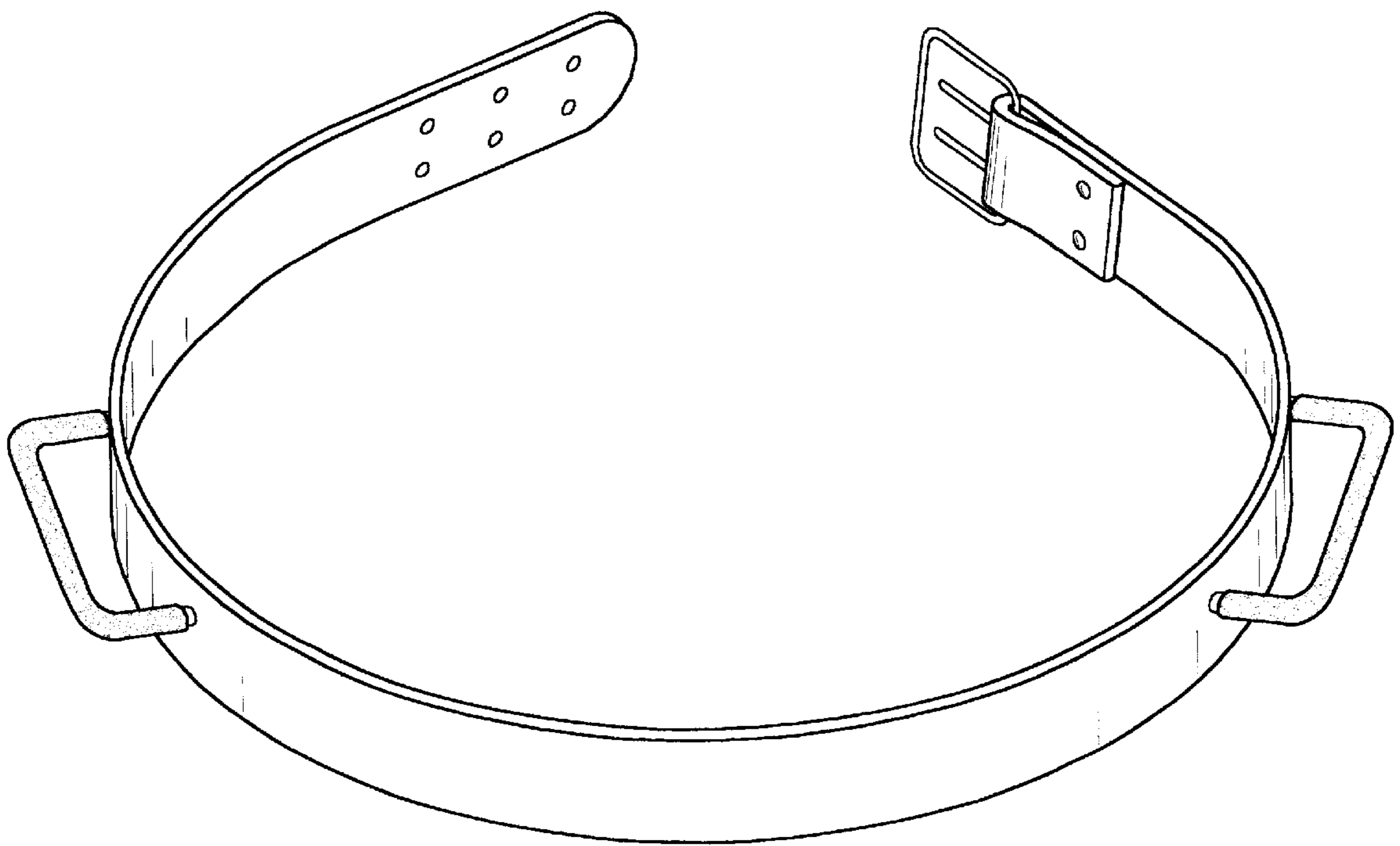

FIG. 6