



US00D480487S

(12) **United States Design Patent**  
**Horowitz**

(10) **Patent No.:** **US D480,487 S**

(45) **Date of Patent:** **\*\* Oct. 7, 2003**

(54) **INTEGRATED REPLACEMENT TAIL LENS ASSEMBLY FOR AUTOMOBILE**

(75) Inventor: **Brian A. Horowitz**, Corona, CA (US)

(73) Assignee: **American Products Company, Inc.**,  
Corona, CA (US)

(\*\*) Term: **14 Years**

(21) Appl. No.: **29/130,119**

(22) Filed: **Sep. 26, 2000**

(51) **LOC (7) Cl.** ..... **26-04**

(52) **U.S. Cl.** ..... **D26/28**

(58) **Field of Search** ..... D26/28-36, 120,  
D26/122; 362/61, 80, 81, 82, 83, 83.4,  
267, 269, 275

(56) **References Cited**

**U.S. PATENT DOCUMENTS**

D388,897 S	*	1/1998	Tomforde et al. ....	D26/28
D389,256 S	*	1/1998	Sacco et al. ....	D26/28
D399,983 S	*	10/1998	Cadotte et al. ....	D26/28
D406,910 S	*	3/1999	Bangle .....	D26/28

**OTHER PUBLICATIONS**

Advertisement—Stillen Sports Cars from *Sport Compact Car*, vol. 13, Nov. 3, Mar., 2001. pp. 58-59.  
Three (3) photographs depicting rear view of Acura Integra automobile.

Advertisement—Stillen Sports Cars from *Sport Compact Car*, vol. 13, No. 3, pp. 58-59, Mar., 2001.  
Three (3) photographs depicting rear view of Acura Integra automobile, prior to Sep. 26, 2000.

American Products Company Y2K Catalog, p. 9, Oct. 21, 1999.

OBX Racing Sports Catalog, p. 1, PRESUMED prior to Sep. 26, 2000.

\* cited by examiner

*Primary Examiner*—Marcus A. Jackson

(74) *Attorney, Agent, or Firm*—Knobbe Martens Olson & Bear LLP

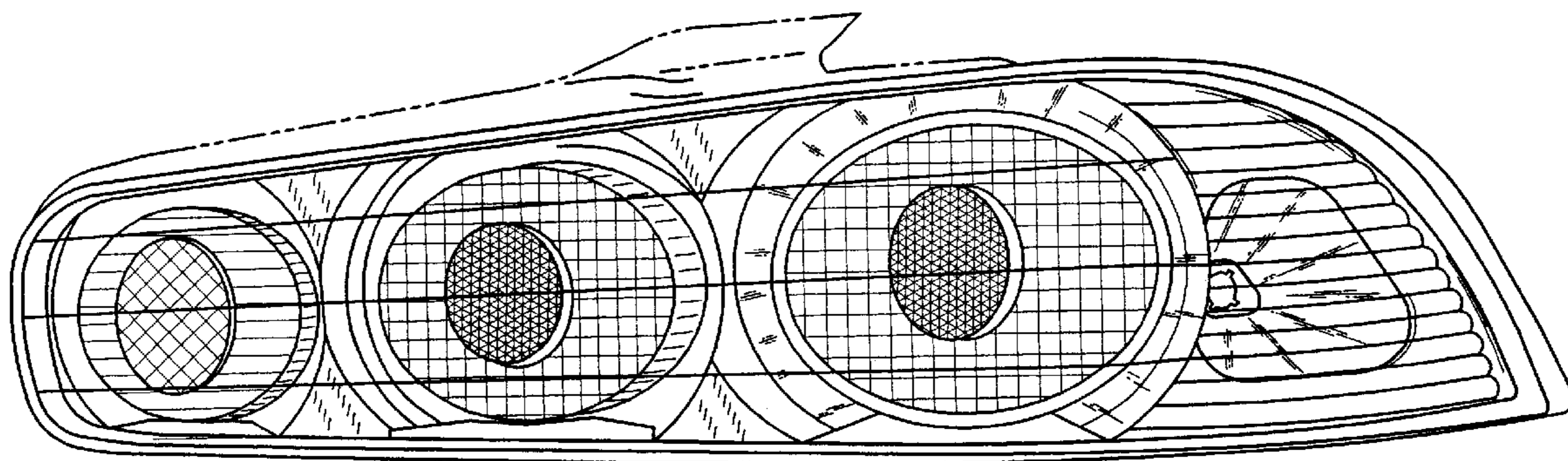
(57) **CLAIM**

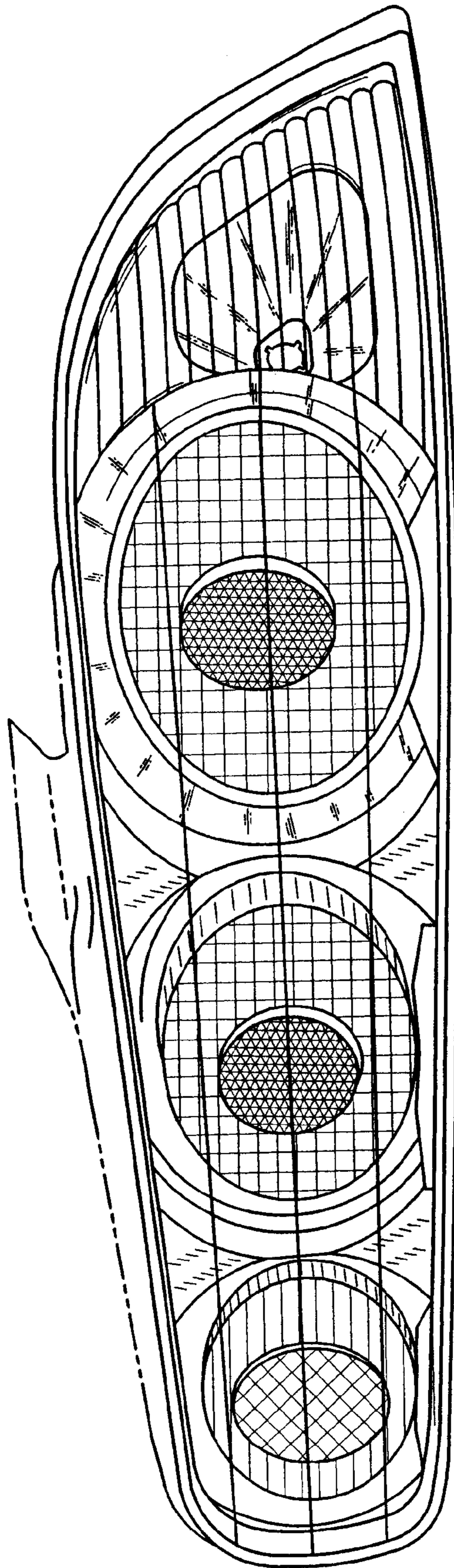
The ornamental design for an integrated replacement tail lens assembly for automobile, as shown and described.

**DESCRIPTION**

FIG. 1 is a right side perspective view of the integrated replacement lens assembly of the present design;  
FIG. 2 is a right side perspective view of the integrated replacement lens assembly of the present design showing the cover removed;  
FIG. 3 is a front view of the integrated replacement lens assembly of the present design;  
FIG. 4 is a right side view of the integrated replacement lens assembly of the present design;  
FIG. 5 is a top sectional view of the integrated replacement lens assembly of the present design; and,  
FIG. 6 is a left side perspective view of the integrated replacement lens assembly of the present design showing the lens assembly installed on an automobile.  
The broken lines showing of the lens assembly in FIG. 5 and of the automobile in FIG. 6 are for illustrative purposes only and form no part of the claimed design.

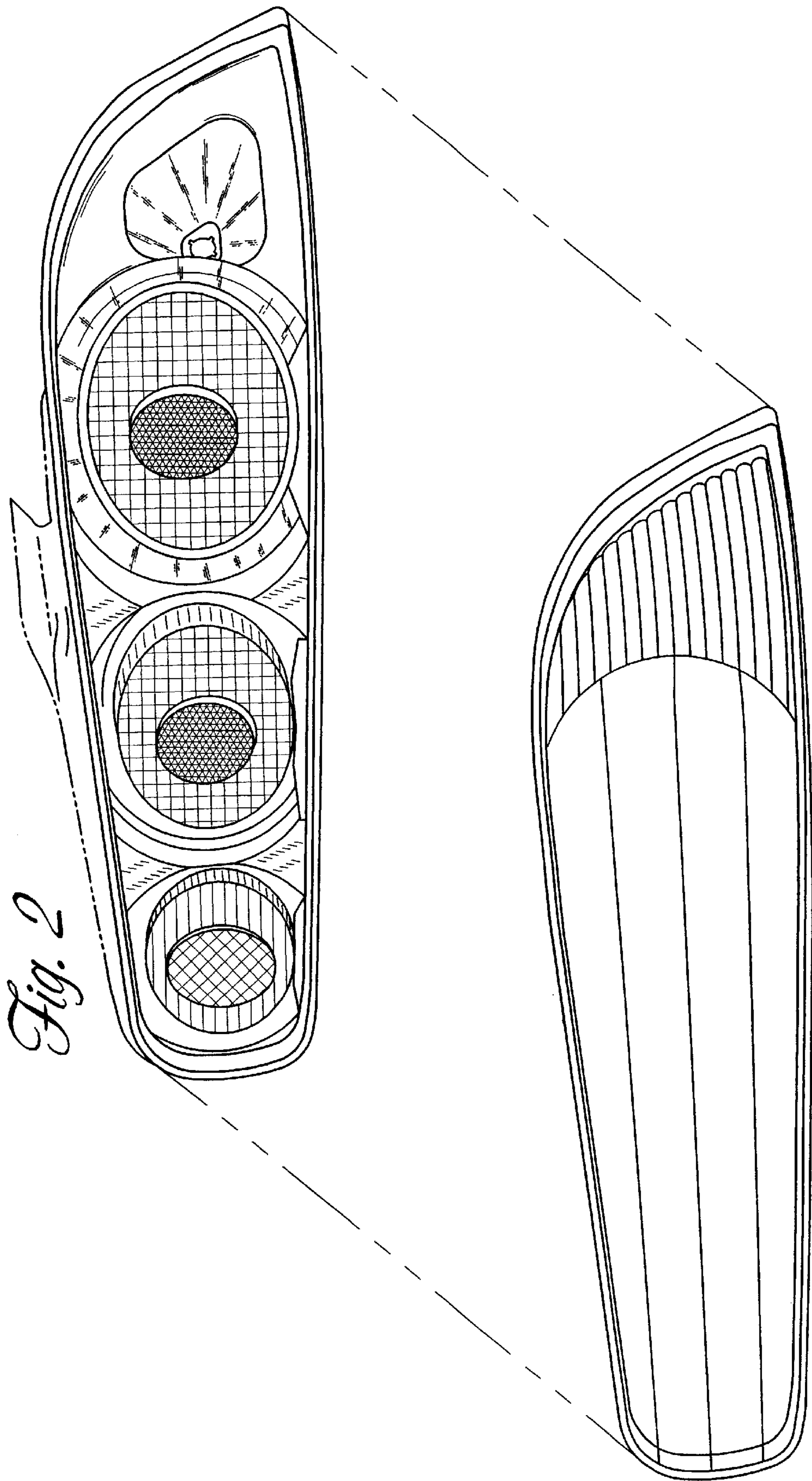
**1 Claim, 6 Drawing Sheets**



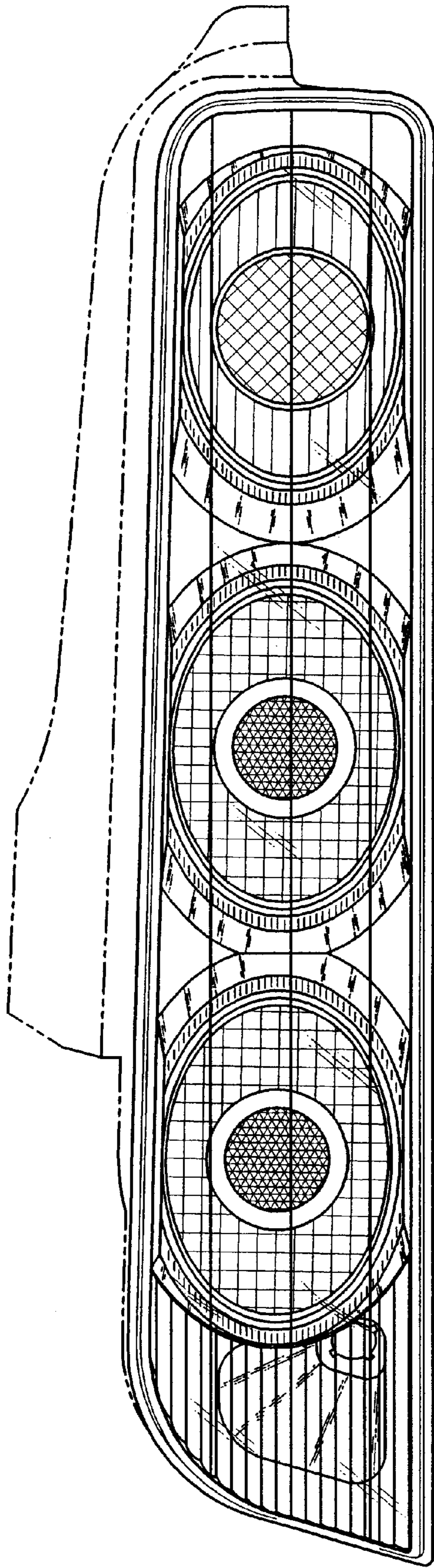


*Fig. 1*

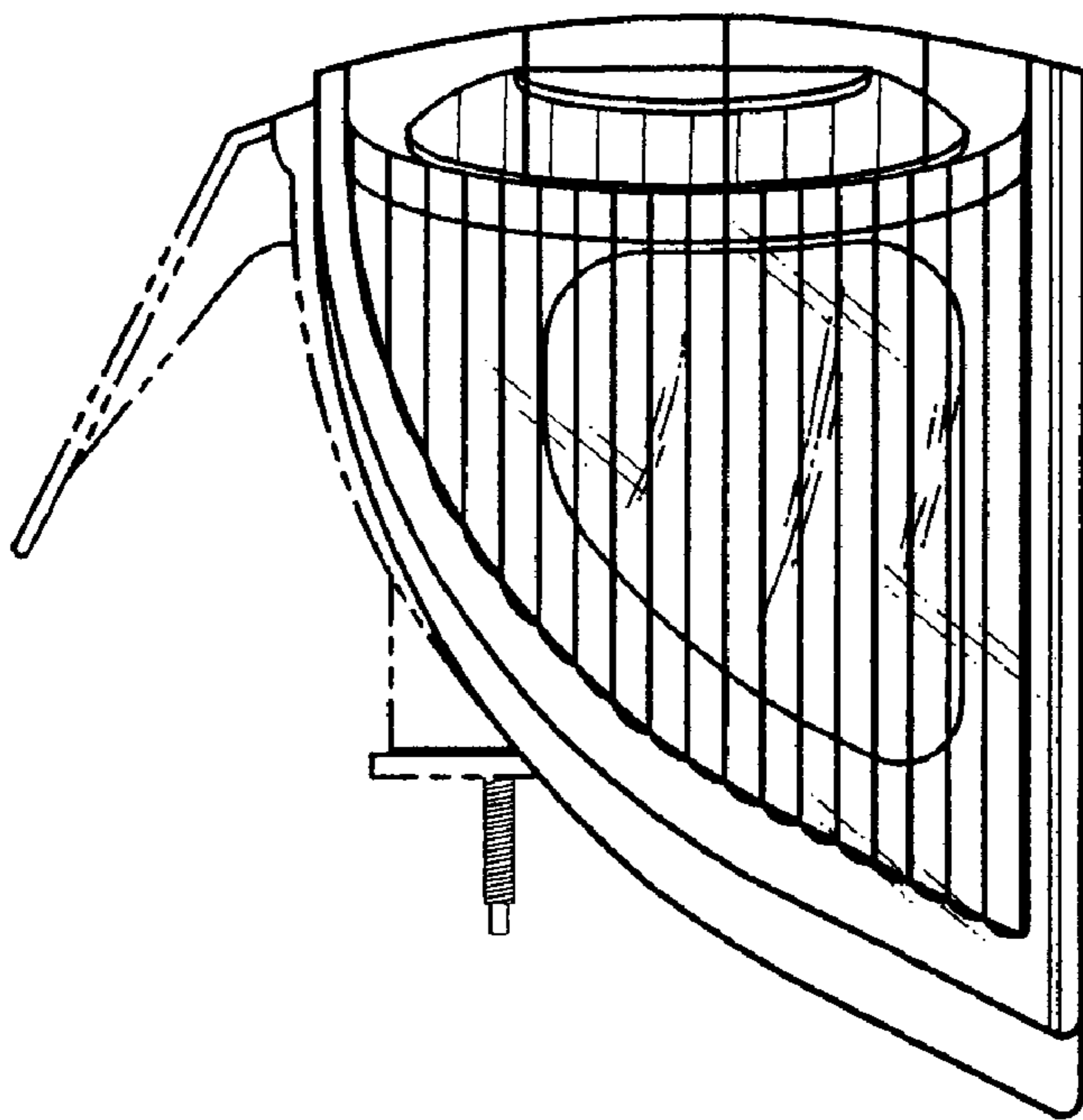




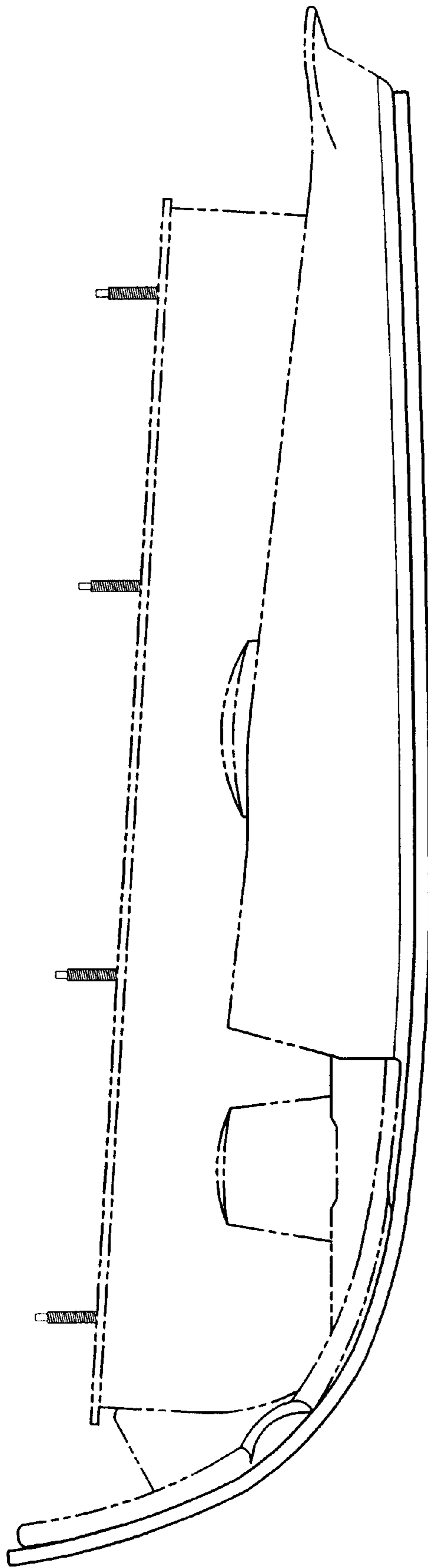
*Fig. 2*



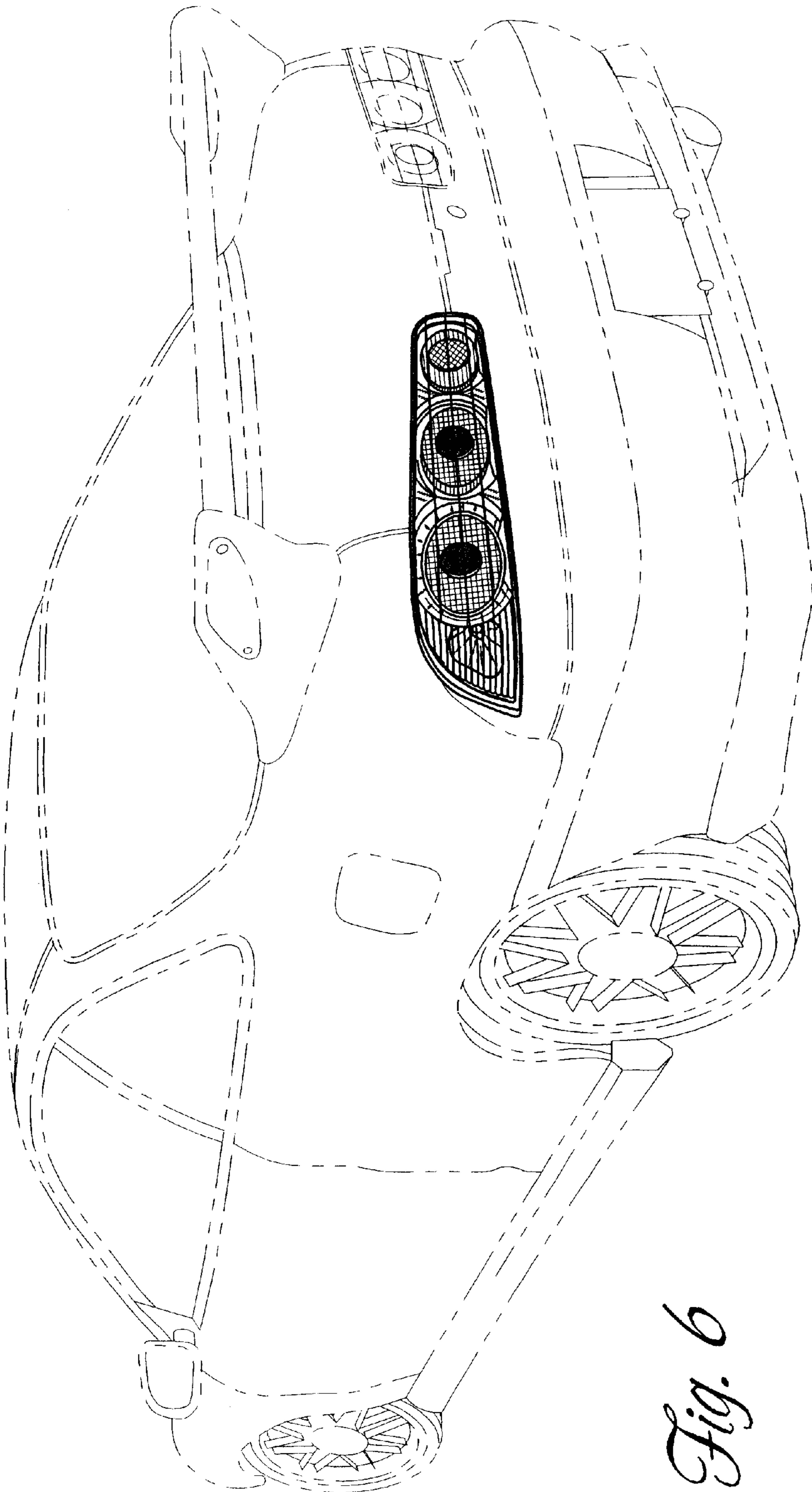
*Fig. 3*



*Fig. 4*



*Fig. 5*



*Fig. 6*