



US00D480347S

(12) **United States Design Patent**
Nemoto

(10) **Patent No.:** **US D480,347 S**

(45) **Date of Patent:** **** Oct. 7, 2003**

- (54) **WHEEL OF AN AUTOMOBILE**
- (75) Inventor: **Tomoyuki Nemoto, Wako (JP)**
- (73) Assignee: **Honda Giken Kogyo Kabushiki Kaisha, Tokyo (JP)**
- (**) Term: **14 Years**
- (21) Appl. No.: **29/149,249**
- (22) Filed: **Oct. 9, 2001**
- (30) **Foreign Application Priority Data**
Apr. 9, 2001 (JP) 2001-010200
- (51) **LOC (7) Cl.** **12-16**
- (52) **U.S. Cl.** **D12/211**
- (58) **Field of Search** D12/204-211;
301/37.101, 64.101, 65

- D465,183 S * 11/2002 Singer D12/211
- D466,069 S * 11/2002 Kataoka D12/211
- D466,466 S * 12/2002 Laengerer D12/211
- D467,215 S * 12/2002 Kern D12/211

FOREIGN PATENT DOCUMENTS

- JP 927884 6/1995
- JP 984200 7/1997

OTHER PUBLICATIONS

DM/046 643, Oct. 8, 1998, Figures 4.1 and 4.2.
DM/012 805, *Bulletin Des Dessins et Modeles Internationaux*, Feb. 1989, Figures 4.1, 4.2 and 4.3, pp. 165-466.

* cited by examiner

Primary Examiner—Stacia Cadmus

(74) *Attorney, Agent, or Firm*—Arent Fox Kintner Plotkin & Kahn, PLLC

(57) **CLAIM**

The ornamental design for a wheel of an automobile, as shown and described.

DESCRIPTION

FIG. 1 is a front view of a wheel of an automobile showing my new design.
FIG. 2 is an enlarged perspective view thereof;
FIG. 3 is a right side view thereof, the left side being identical to the right side.
FIG. 4 is a plan view thereof; and,
FIG. 5 is a bottom view thereof.

1 Claim, 4 Drawing Sheets

- (56) **References Cited**
- U.S. PATENT DOCUMENTS**
- D208,542 S * 9/1967 Halibrand D12/211
- D236,975 S * 9/1975 May D12/209
- D432,972 S * 10/2000 Chung D12/209
- D438,165 S * 2/2001 Echazabal D12/211
- D444,118 S * 6/2001 Chung D12/211
- D446,493 S * 8/2001 Sulahian et al. D12/211
- D454,107 S * 3/2002 Chung D12/211
- D455,703 S * 4/2002 Foose D12/211
- D456,335 S * 4/2002 Chung D12/211
- D459,691 S * 7/2002 Takechi D12/211
- D461,758 S * 8/2002 Takechi D12/211

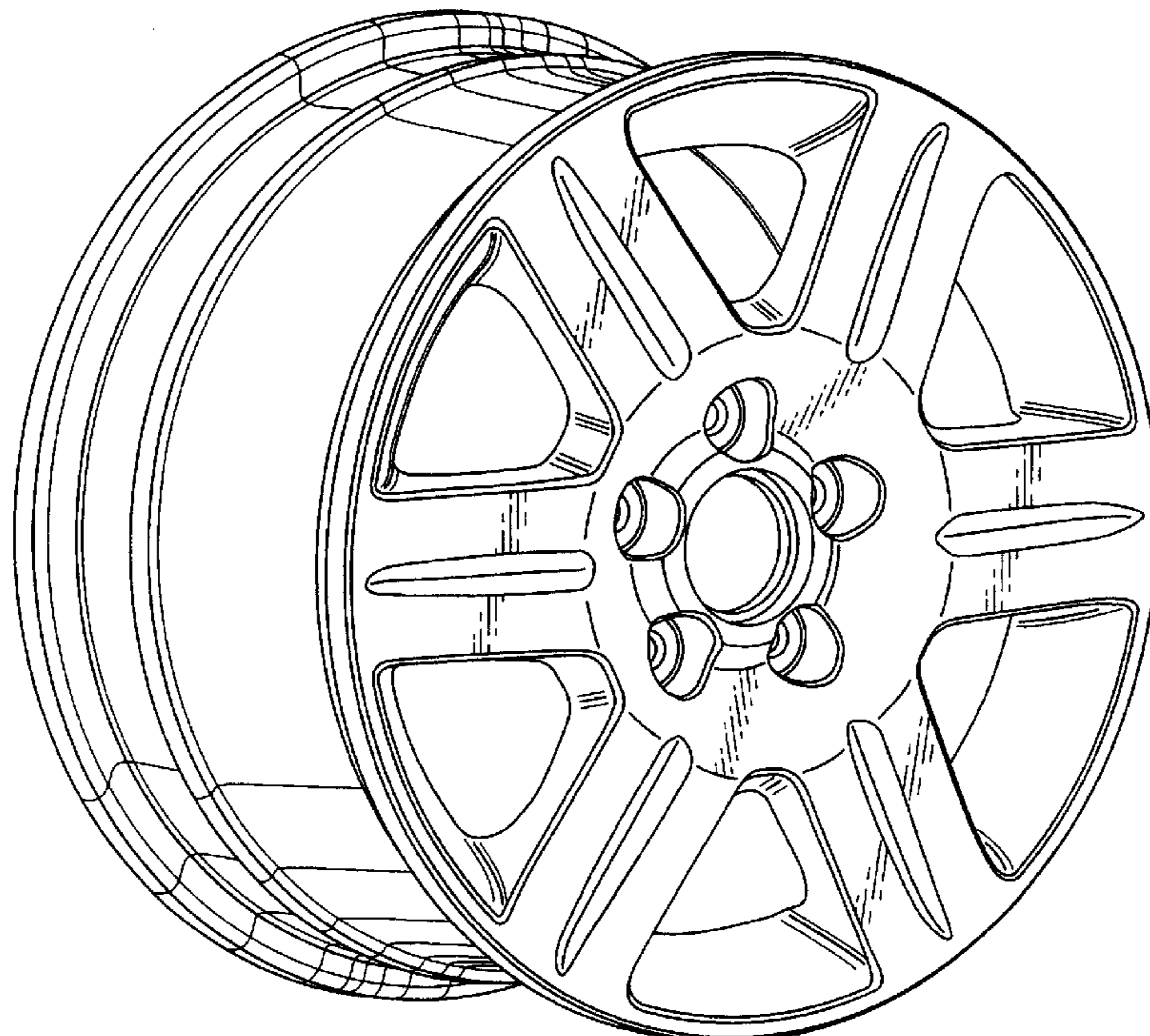

FIG. 1

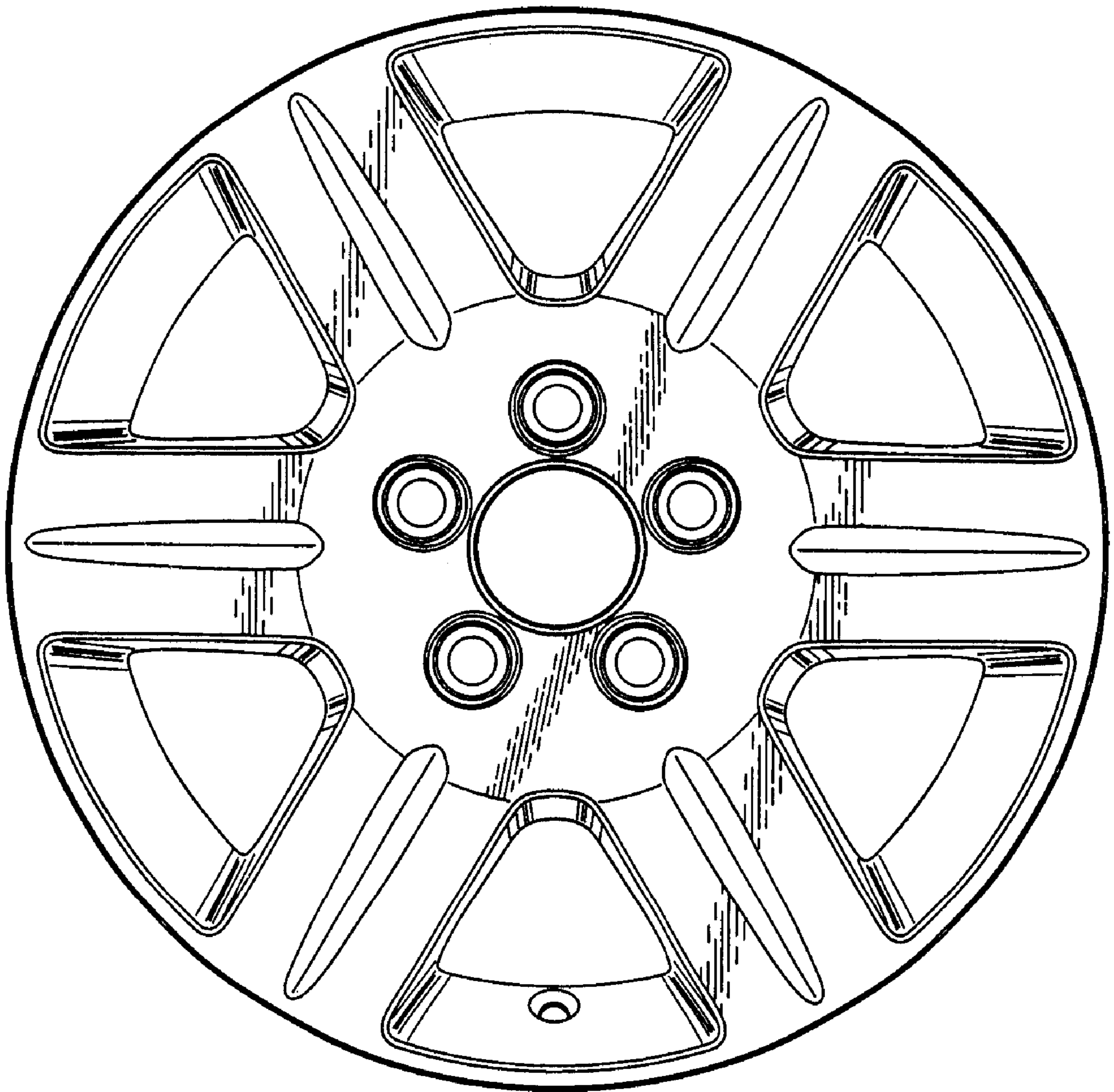

FIG. 2

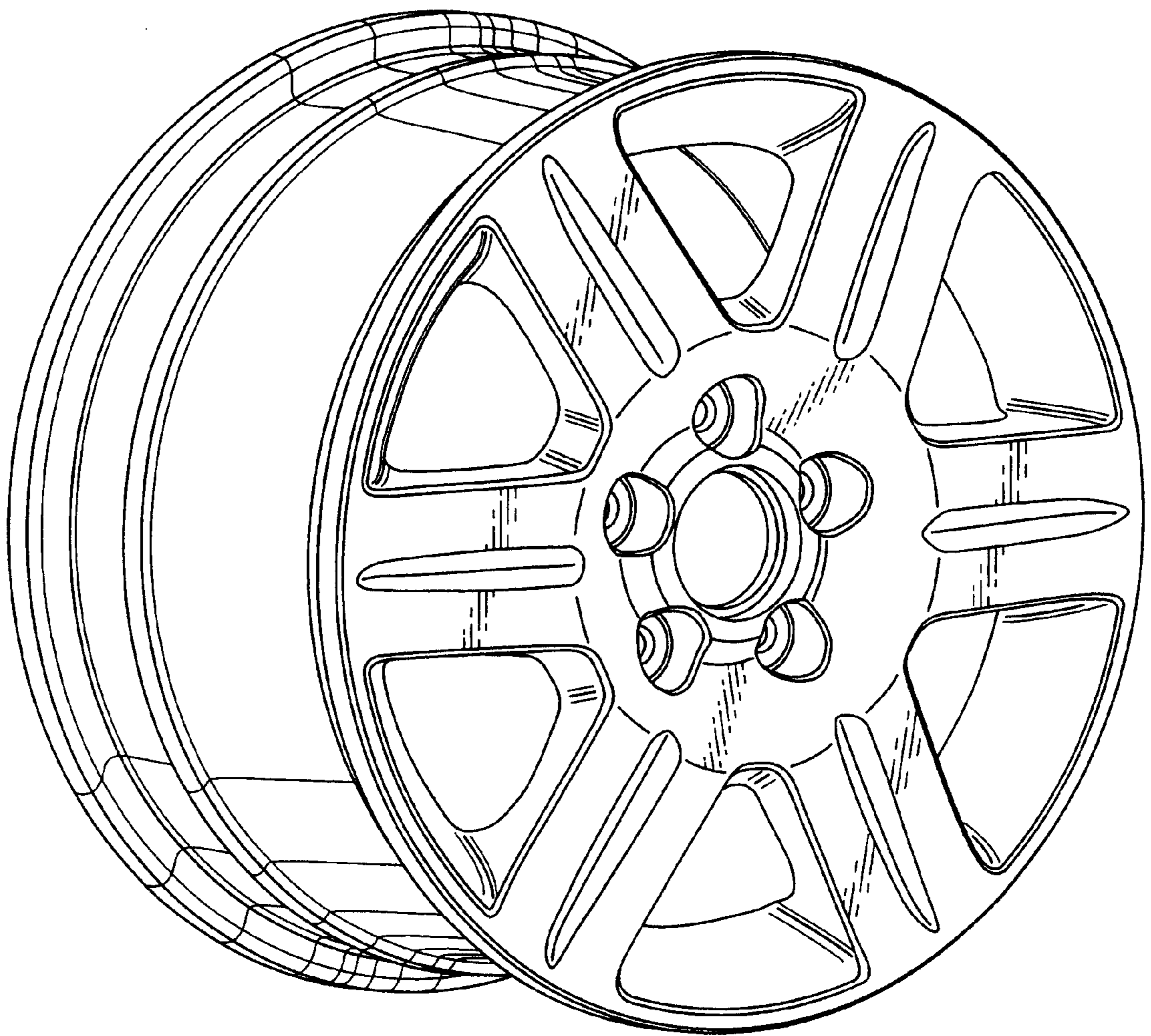

FIG. 3

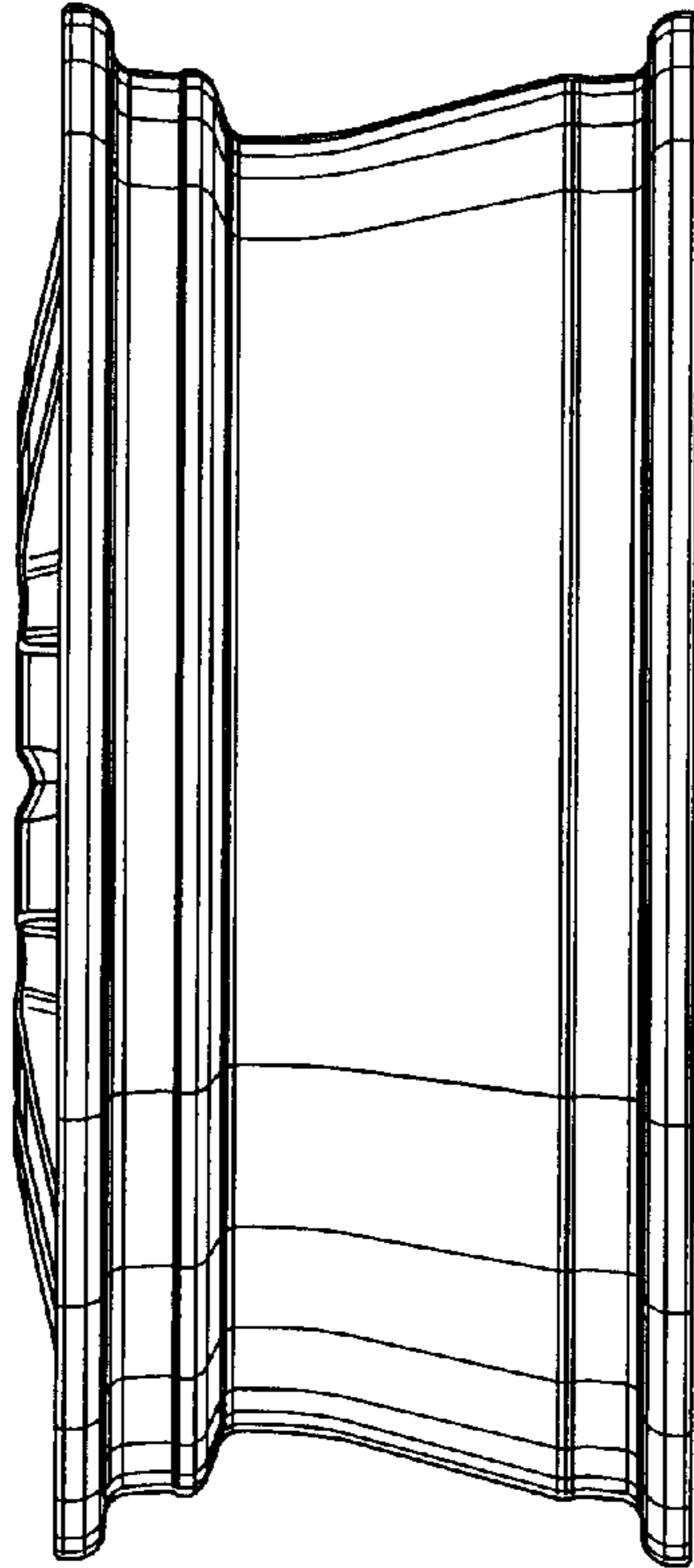

FIG. 4

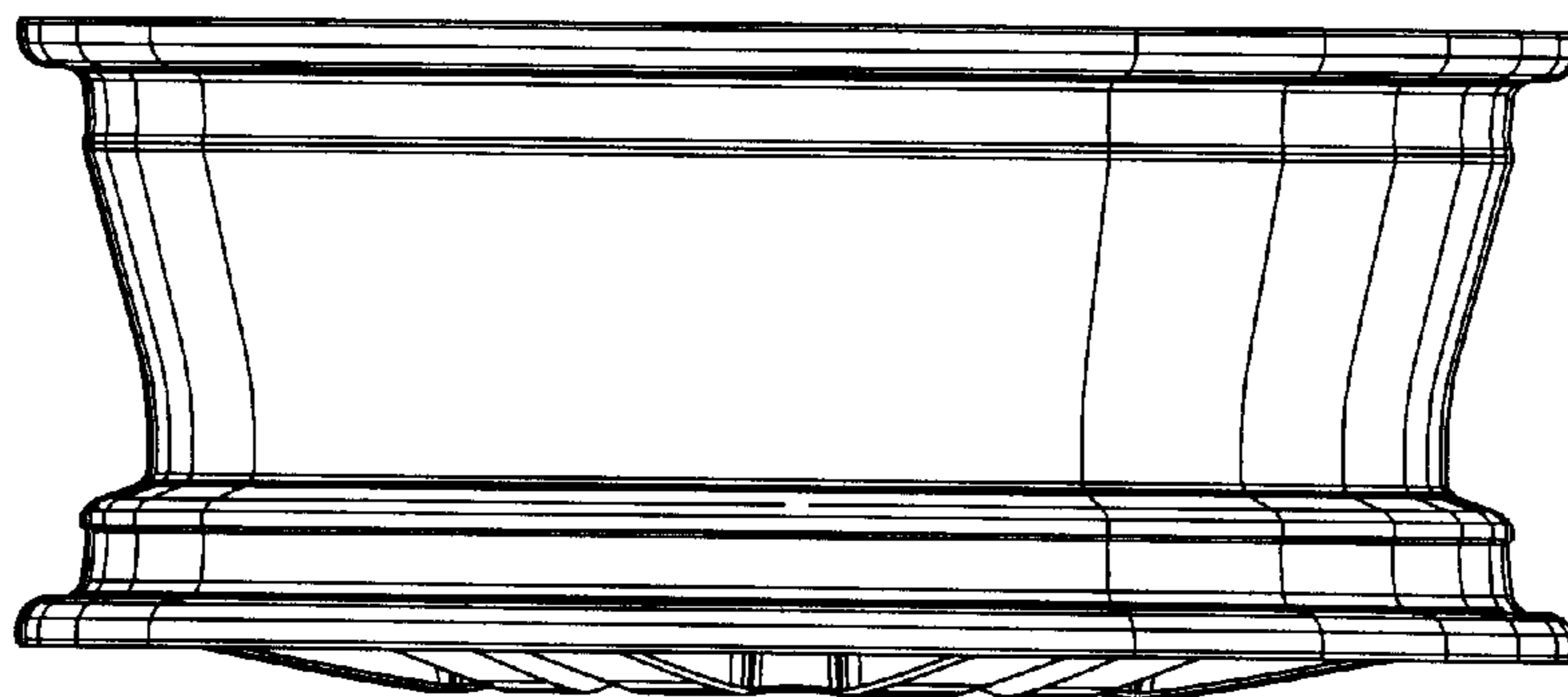

FIG. 5

