



US00D480133S

(12) **United States Design Patent**
Chen

(10) **Patent No.:** **US D480,133 S**

(45) **Date of Patent:** **** Sep. 30, 2003**

(54) **COMBINED MOTOR HOUSING, SUPPORT ROD AND CANOPY FOR A MULTI-ROTOR CEILING FAN**

Primary Examiner—Lisa Lichtenstein
(74) *Attorney, Agent, or Firm*—Rosenberg, Klein & Lee

(76) **Inventor:** **Chia-Teh Chen, P.O.Box 26-757, Taipei (TW)**

(57) **CLAIM**

The ornamental design for a combined motor housing, support rod and canopy for a multi-rotor ceiling fan, as shown and described.

(**) **Term:** **14 Years**

DESCRIPTION

(21) **Appl. No.:** **29/159,332**

FIG. 1 is the perspective view of a combined motor housing, support rod and canopy for a multi-rotor ceiling fan showing my new design;

(22) **Filed:** **Apr. 15, 2002**

FIG. 2 is the front view thereof;

(51) **LOC (7) Cl.** **23-04**

FIG. 3 is the rear view thereof;

(52) **U.S. Cl.** **D23/411; D23/377; D23/379; D23/385**

FIG. 4 is the left side view thereof;

(58) **Field of Search** **D23/377, 379, D23/385, 411; 416/5**

FIG. 5 is the right side view thereof;

FIG. 6 is the top view thereof; and,

FIG. 7 is the bottom view thereof.

(56) **References Cited**

U.S. PATENT DOCUMENTS

D426,630 S	*	6/2000	Gajewski	D23/377
D427,672 S	*	7/2000	Lee	D23/377
D434,844 S	*	12/2000	Williams	D23/377

The broken line showing of environmental structure in FIGS. 1-7 is for illustrative purposes only and forms no part of the claimed design.

* cited by examiner

1 Claim, 7 Drawing Sheets

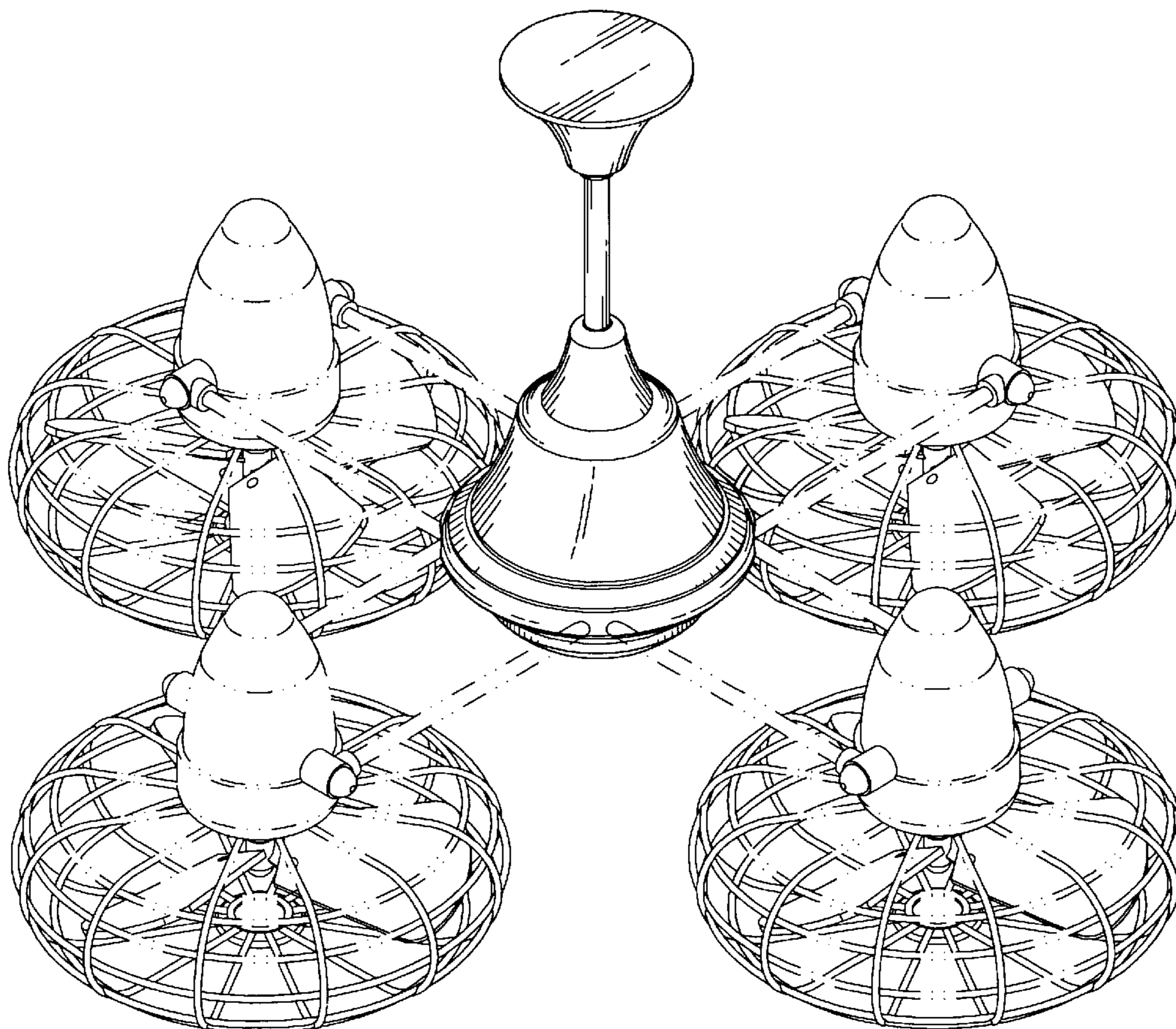

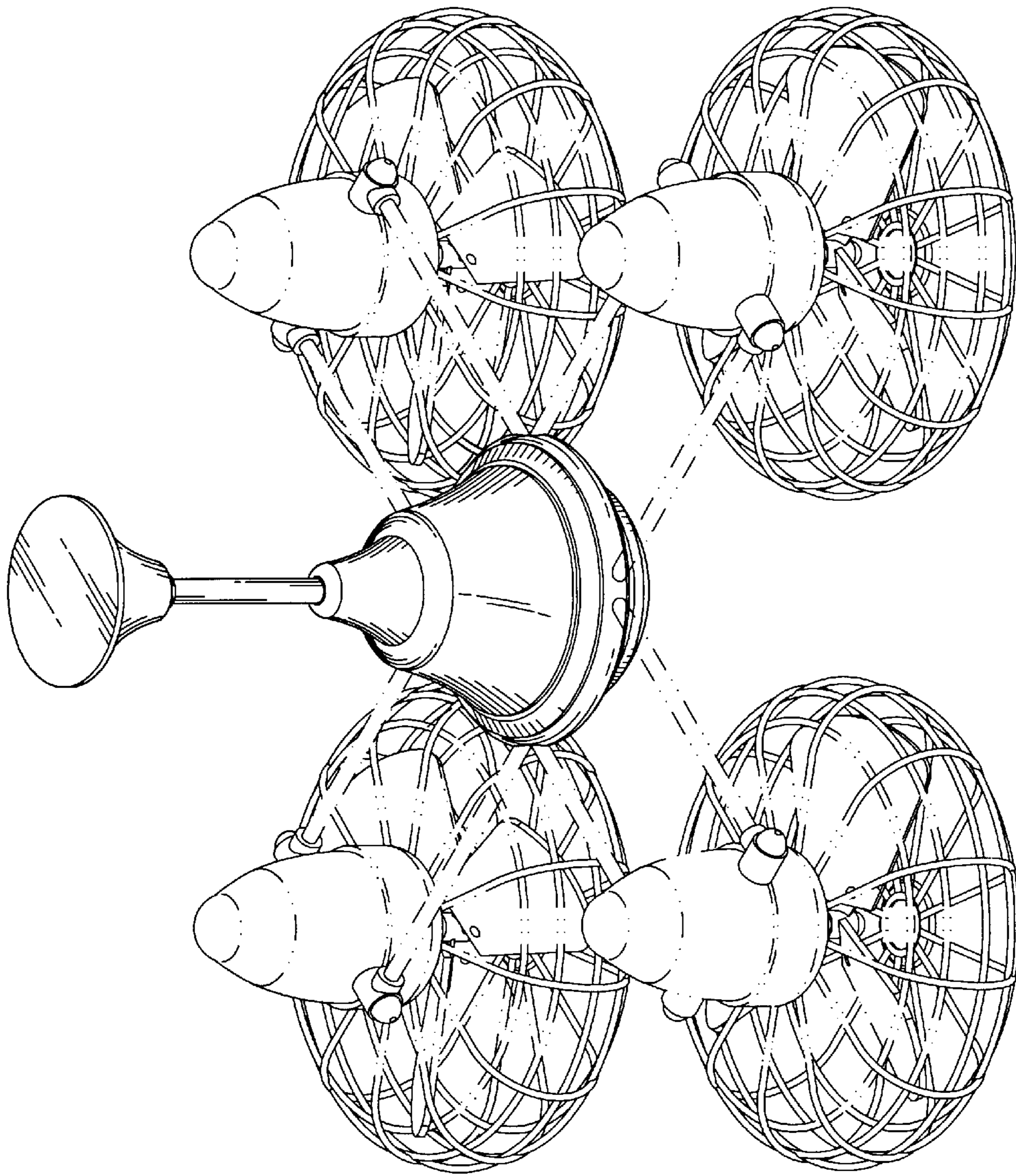

FIG. 1

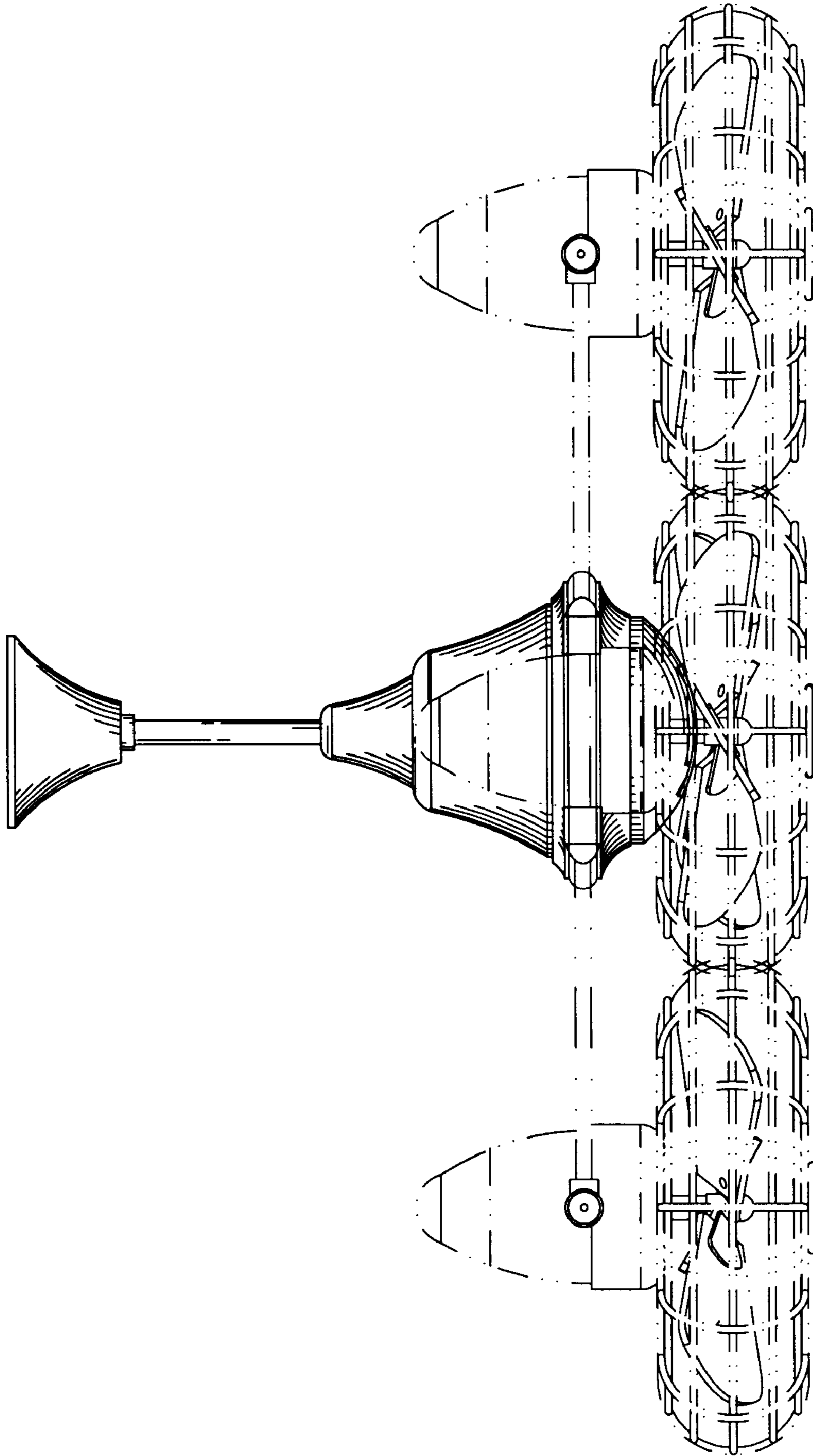

FIG. 2

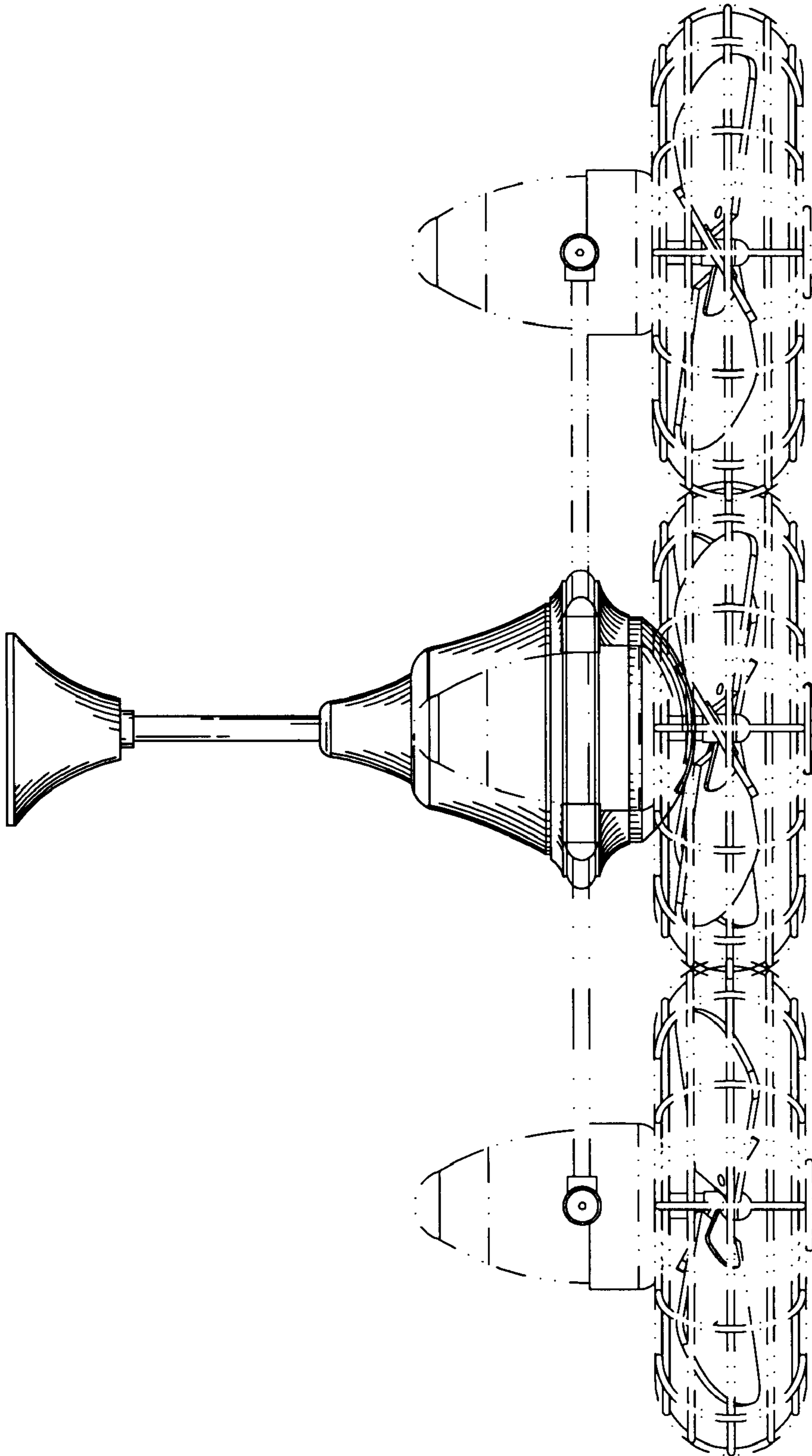

FIG. 3

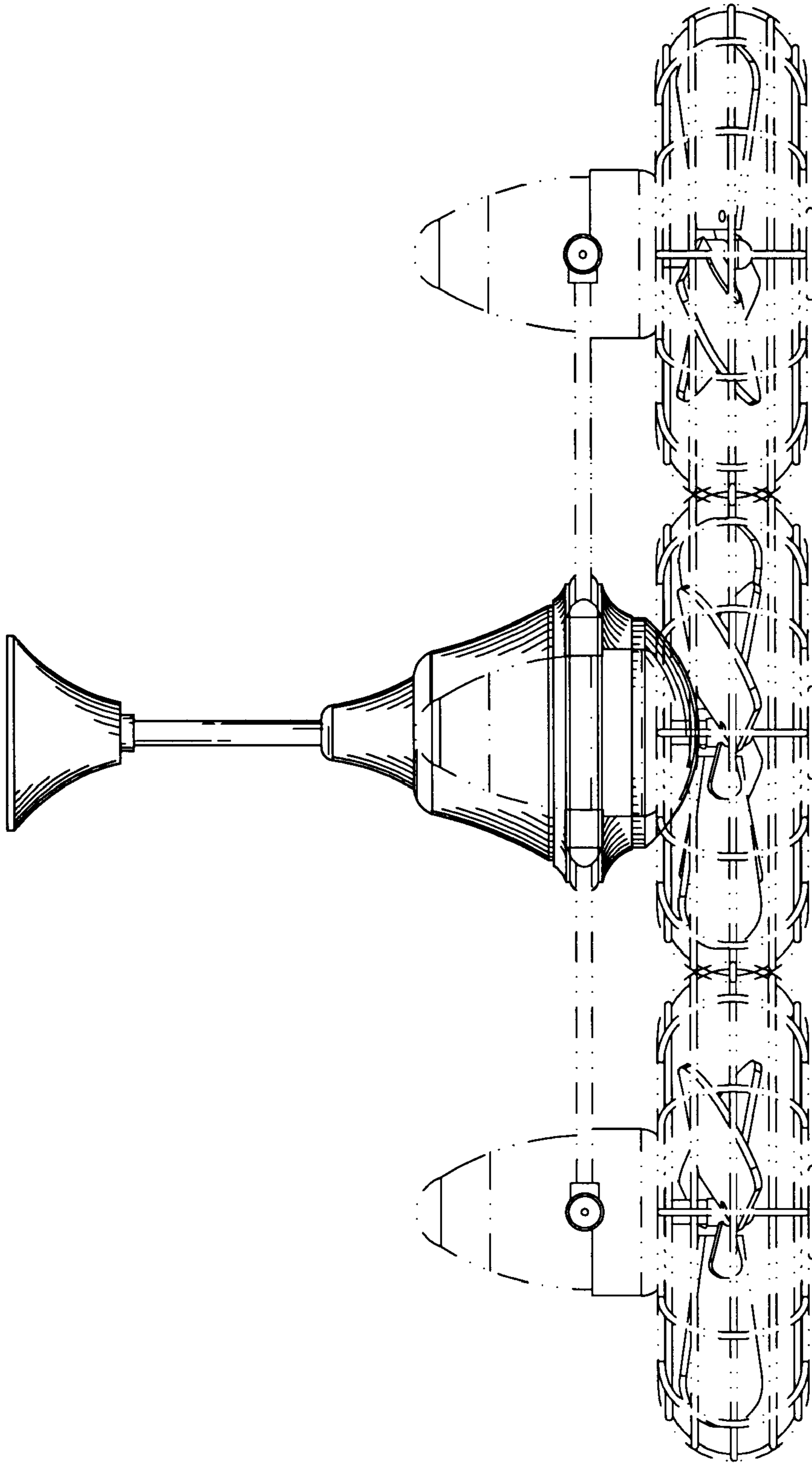

FIG. 4

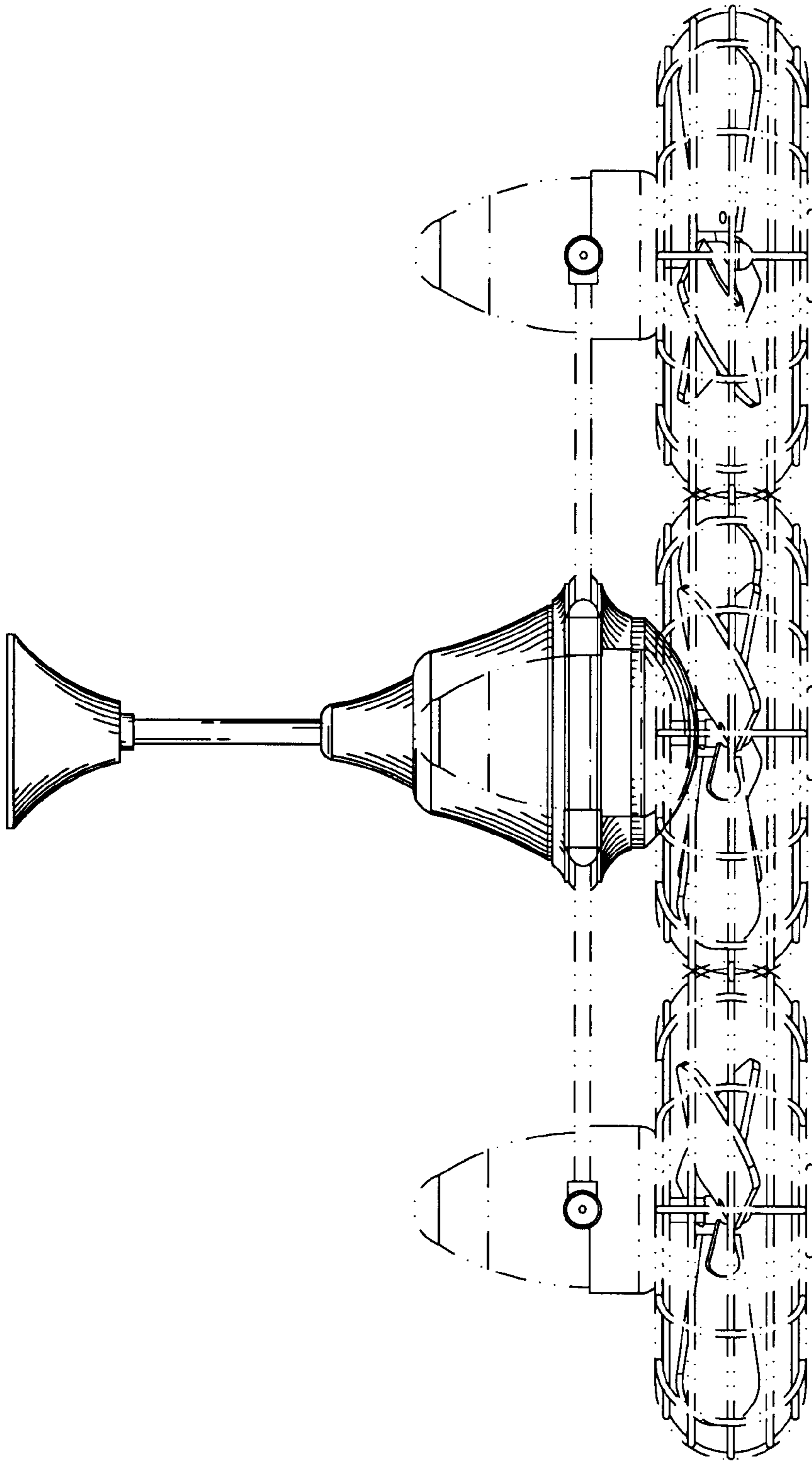

FIG. 5

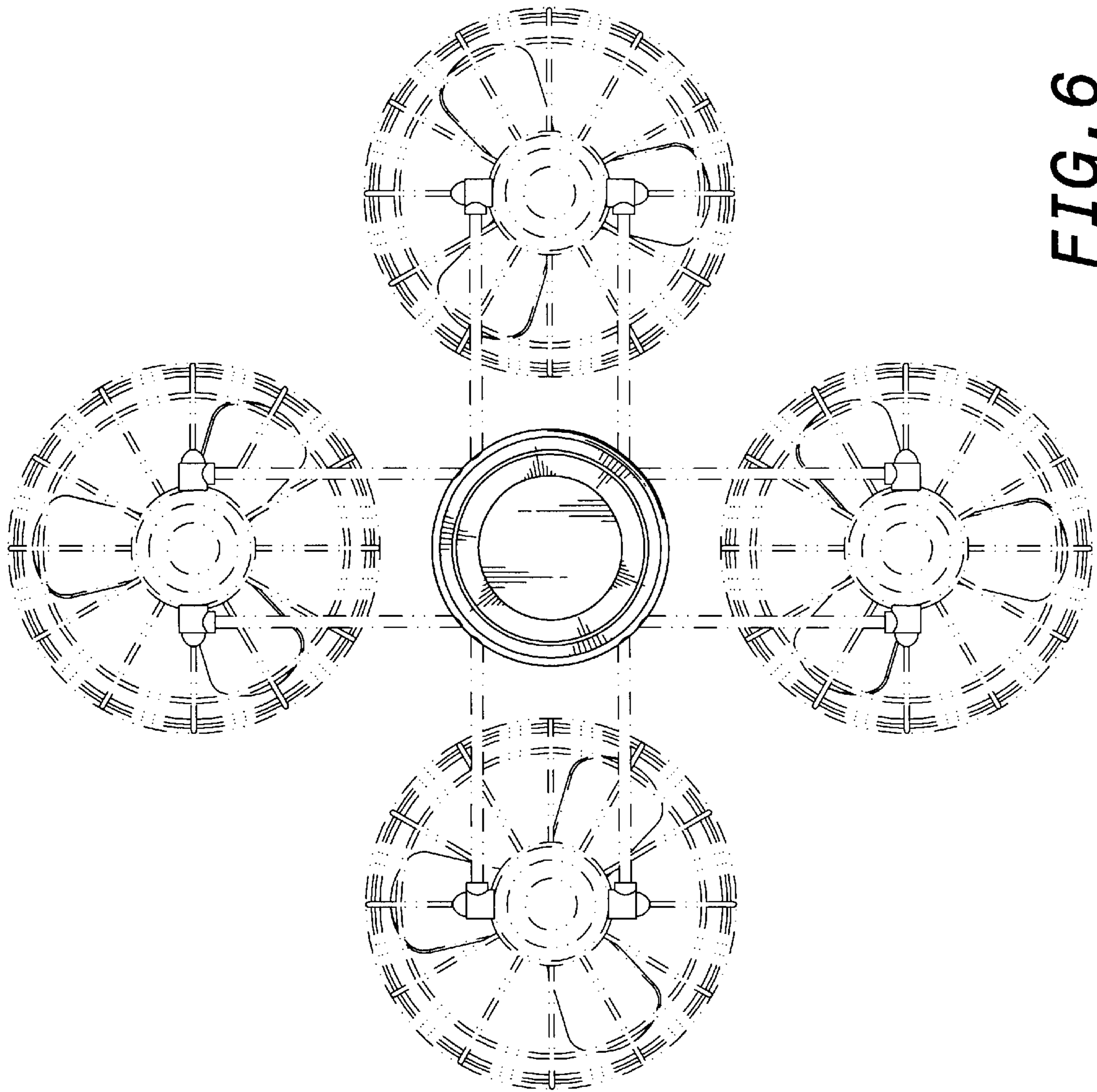

FIG. 6

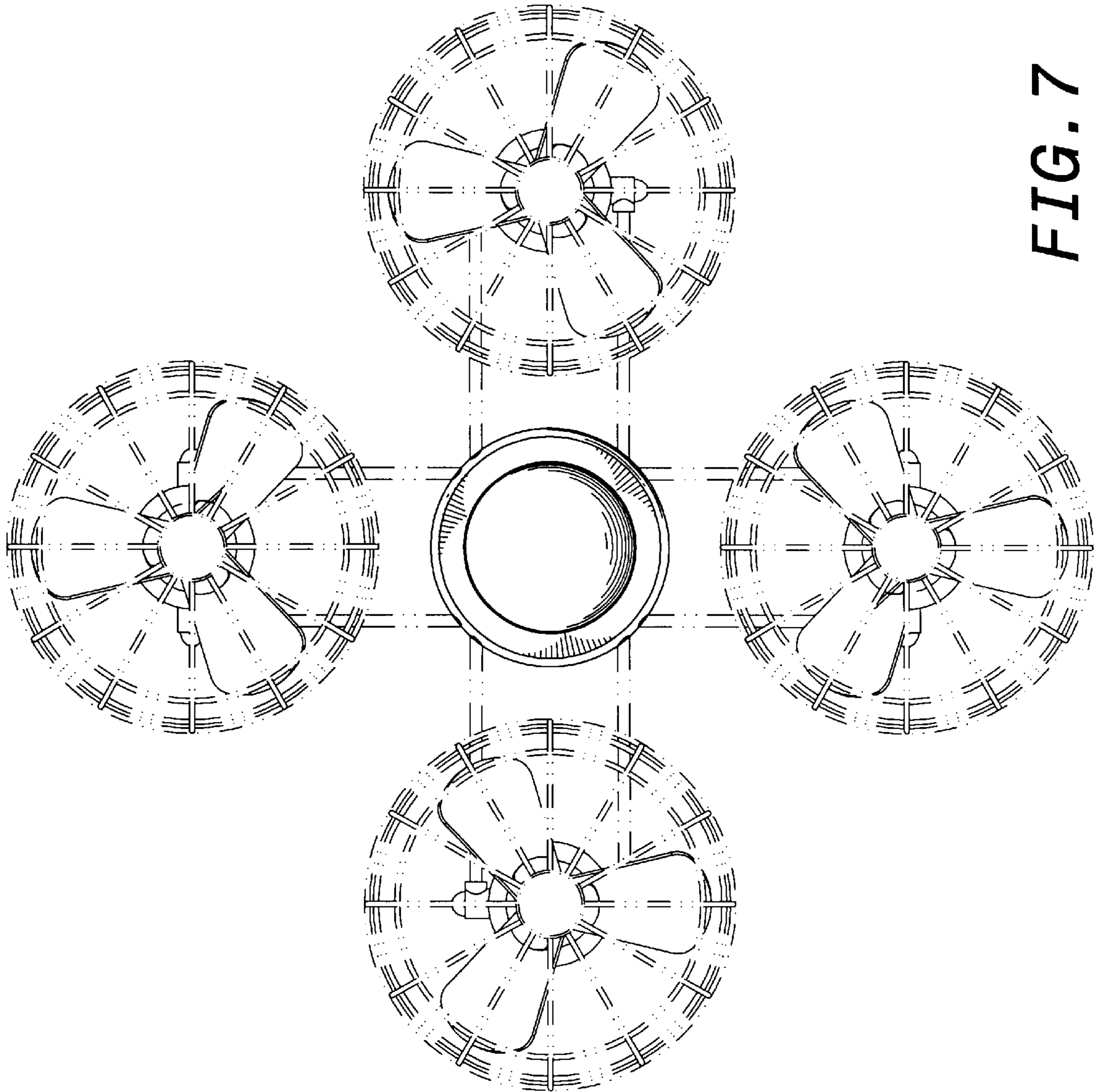

FIG. 7