



US00D480043S

(12) **United States Design Patent**
Hiroko

(10) **Patent No.:** **US D480,043 S**

(45) **Date of Patent:** **** Sep. 30, 2003**

(54) **TIRE TREAD**

(75) Inventor: **Okano Hiroko**, Kobe (JP)

(73) Assignee: **The Goodyear Tire & Rubber Company**, Akron, OH (US)

(**) Term: **14 Years**

(21) Appl. No.: **29/172,895**

(22) Filed: **Dec. 18, 2002**

(30) **Foreign Application Priority Data**

Jul. 5, 2002 (JP) 2002-018149

(51) **LOC (7) Cl.** **12-15**

(52) **U.S. Cl.** **D12/590**

(58) **Field of Search** D12/586, 587,
D12/588, 589, 590, 591, 594, 595, 600,
601, 90; 152/209.1, 209.9, 209.13, 209.18,
209.19

(56) **References Cited**

U.S. PATENT DOCUMENTS

D367,835 S * 3/1996 Killian D12/590

D386,730 S * 11/1997 Hubbell, Jr. D12/588

* cited by examiner

Primary Examiner—Robert M. Spear

(74) *Attorney, Agent, or Firm*—David L. King

(57) **CLAIM**

The ornamental Design for a tire tread, as shown and described.

DESCRIPTION

FIG. 1 is a perspective view of a tire tread showing my new design, it being understood that the pattern repeats uniformly throughout the circumference of the tread;

FIG. 2 is a front elevational view thereof;

FIG. 3 is a right side elevational view thereof, the opposite side elevational view being identical thereto; and,

FIG. 4 is an enlarged fragmentary perspective view.

In the drawings, the broken lines defining the sidewall, inner bead and the peripheral boundary between the tire tread and the sidewall are for illustrative purposes only and form no part of the claimed design.

The dark stippled surface shading represents the recessed portion of the tread grooves having a depth as best shown in FIG. 2.

1 Claim, 4 Drawing Sheets

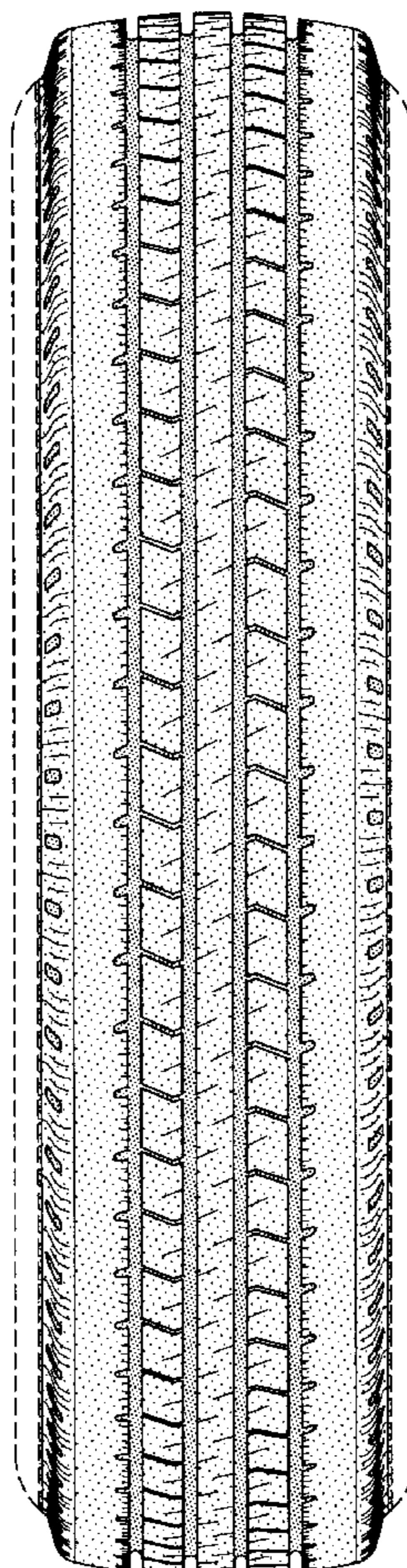

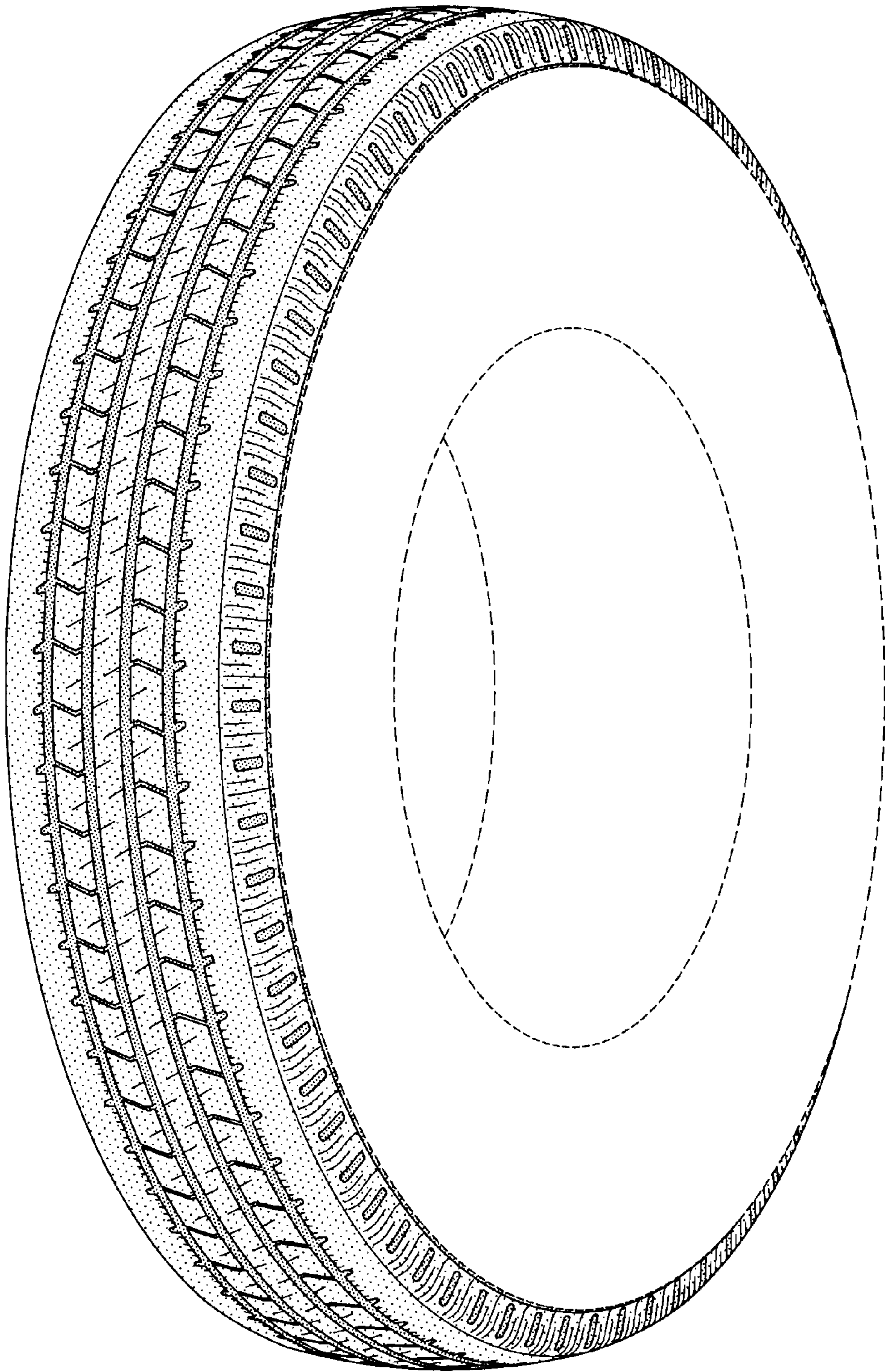

FIG-1

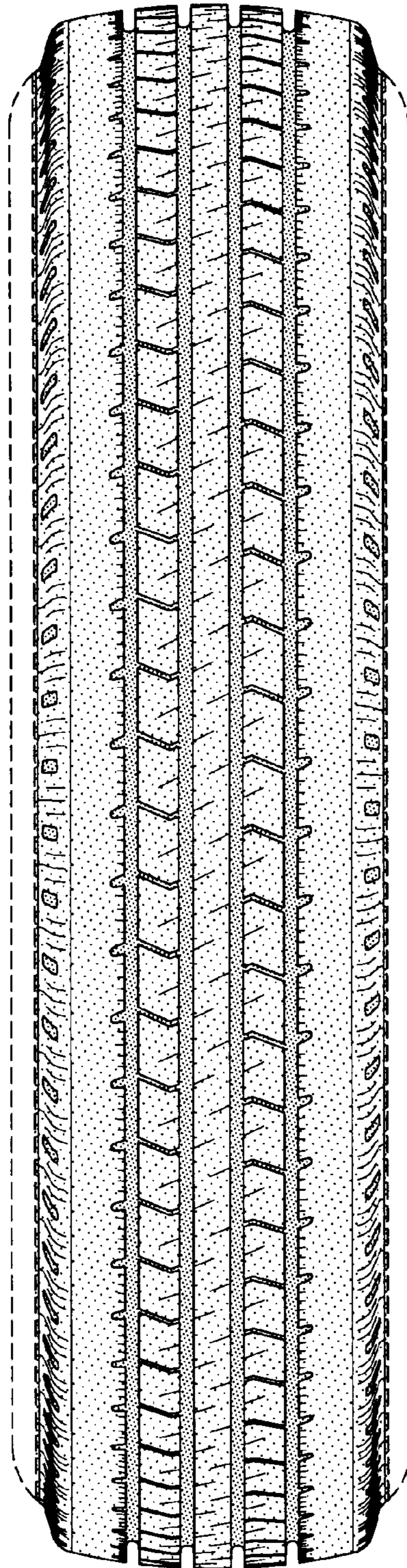

FIG-2

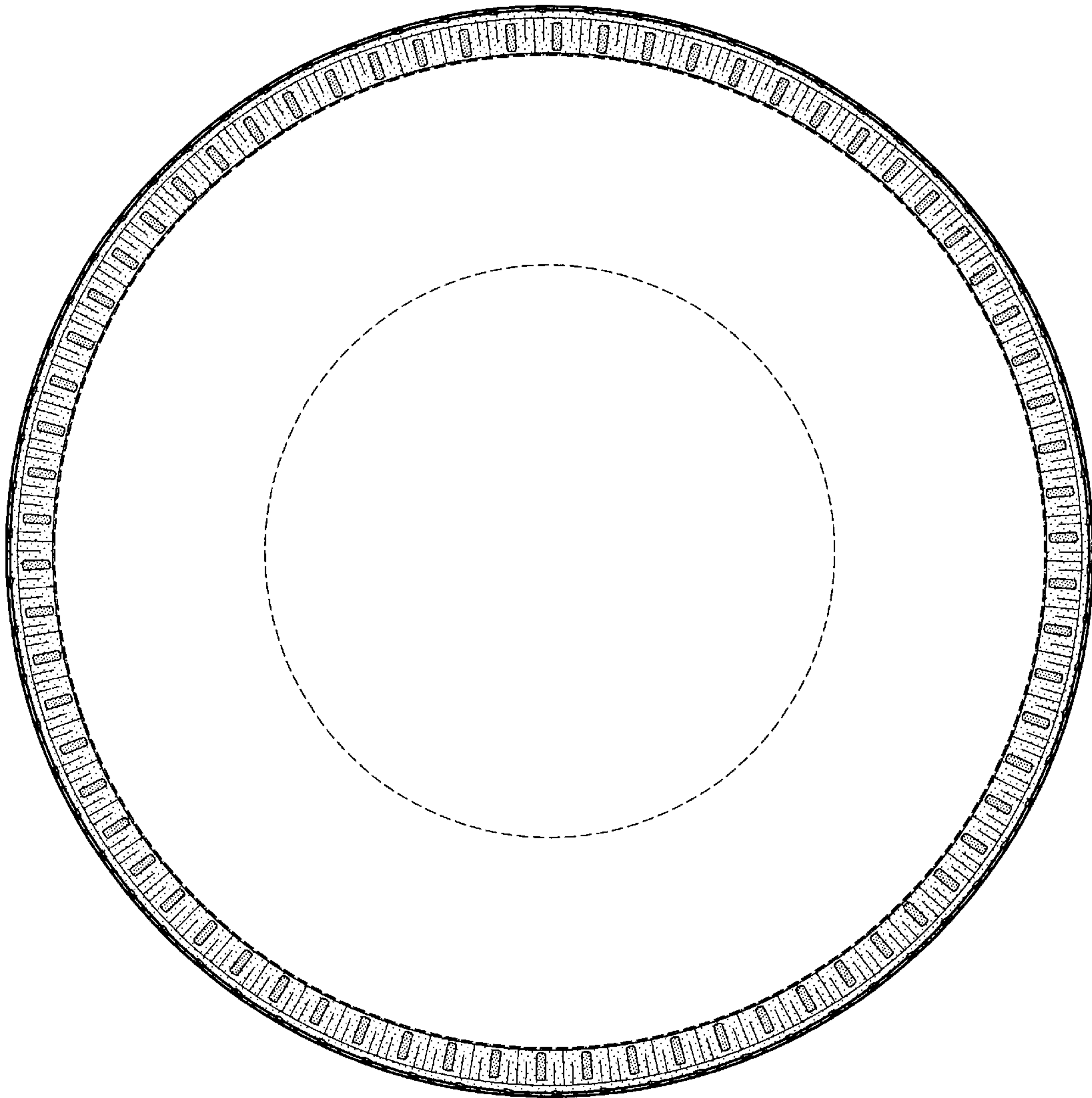

FIG-3

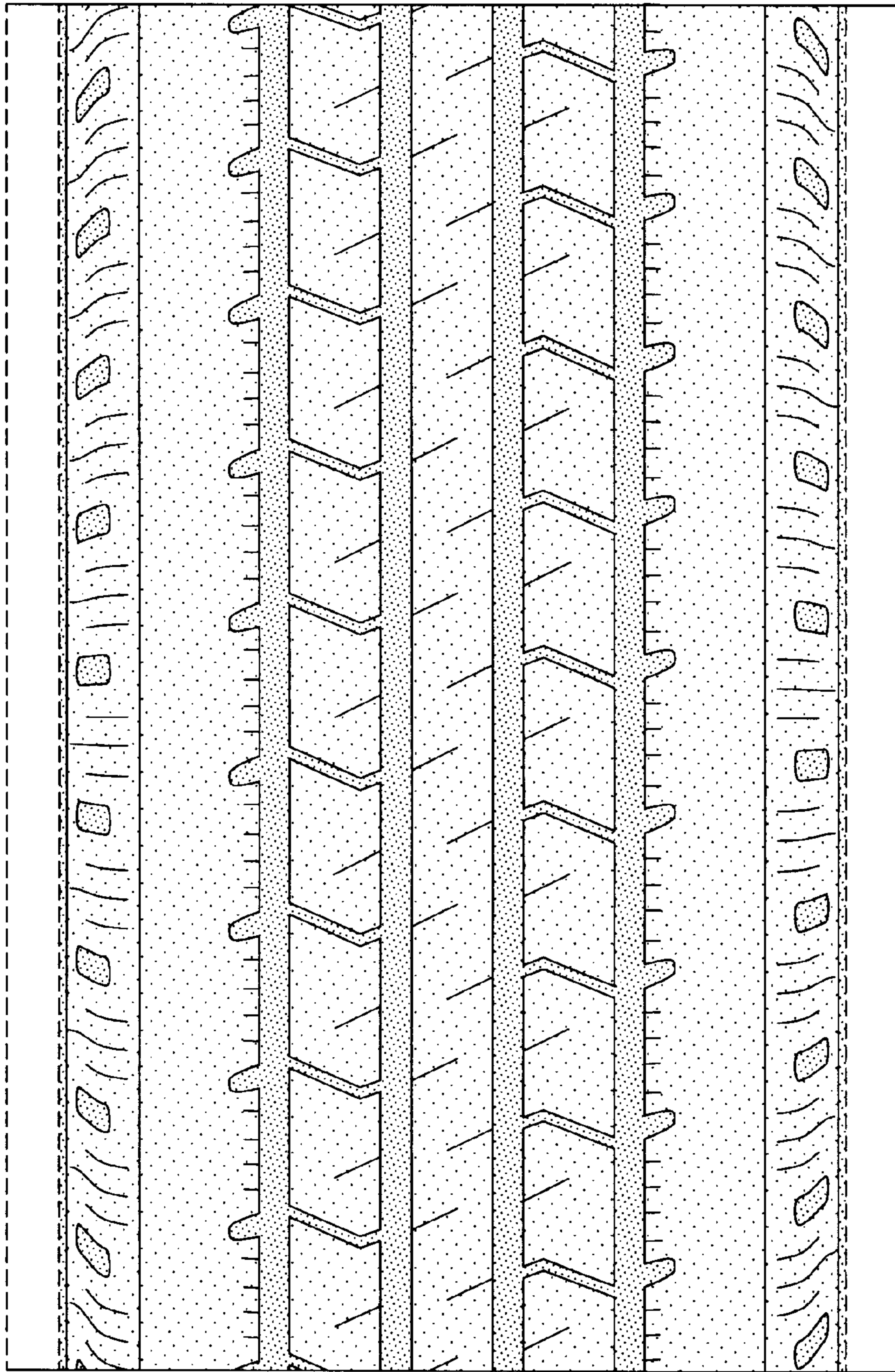

FIG-4