



US00D479859S

(12) **United States Design Patent**
Strunk et al.

(10) **Patent No.:** **US D479,859 S**

(45) **Date of Patent:** **** Sep. 23, 2003**

(54) **DISPLAY APPARATUS**

(75) Inventors: **David D. Strunk**, Weddington, NC
(US); **Aaron D. Kephart**, Charlotte,
NC (US)

(73) Assignee: **Bank of America Corporation**,
Charlotte, NC (US)

(**) Term: **14 Years**

(21) Appl. No.: **29/158,852**

(22) Filed: **Apr. 12, 2002**

(51) **LOC (7) Cl.** **20-02**

(52) **U.S. Cl.** **D20/41**

(58) **Field of Search** D20/10, 19, 39,
D20/40, 41, 99; D26/34; D99/28; 40/559,
584, 607, 611; 707/1

(56) **References Cited**

U.S. PATENT DOCUMENTS

D80,647 S *	3/1930	Thomas	D6/321
2,720,718 A *	10/1955	Vaniman	40/603
4,375,134 A *	3/1983	Sheetz	40/591
4,790,092 A *	12/1988	Farmer	40/607.09
D301,491 S *	6/1989	Walter	D20/43
4,959,916 A *	10/1990	Cochrane	40/603
5,267,524 A *	12/1993	Maxwell	116/174
5,305,195 A	4/1994	Murphy		
D362,465 S *	9/1995	Gallemore, II	D20/41
5,473,143 A	12/1995	Vak et al.		
5,489,076 A *	2/1996	Thomas	248/150
5,619,558 A	4/1997	Jheeta		
5,634,286 A *	6/1997	Johnson	40/564
5,764,736 A	6/1998	Shachar et al.		
5,870,724 A	2/1999	Lawlor et al.		
5,933,811 A	8/1999	Angles et al.		
6,004,002 A *	12/1999	Giannone	40/559
6,035,280 A	3/2000	Christensen		
D427,102 S *	6/2000	Irizarry et al.	D10/109
6,085,177 A	7/2000	Semple et al.		
6,108,437 A	8/2000	Lin		
D433,713 S *	11/2000	Olivetti	D20/10
D434,082 S *	11/2000	Tsiogas	D20/41

6,144,944 A	11/2000	Kurtzman, II et al.		
6,149,055 A	11/2000	Gatto		
6,264,560 B1	7/2001	Goldberg et al.		
D453,194 S *	1/2002	Gentelia et al.	D20/41
D470,189 S *	2/2003	Bguyen	D20/41
2001/0029528 A1	10/2001	Coutts et al.		

OTHER PUBLICATIONS

In Touch with Your Business, Elo TouchSystems, at <http://www.elotouch.com> (printed on Aug. 5, 2002). 13 pages.
GlassVu/Transvu/LumenStar/HoloGraphic Presentations at <http://www.glassvu.ca/home.html> (printed on Aug. 5, 2002). 6 pages.

Lee, W.A., "Customized Ads, Coming to ATMs?" American Banker, Sep. 5, 2000, vol. 169, No. 166, p. 8.

(List continued on next page.)

Primary Examiner—Robert M. Spear

(74) *Attorney, Agent, or Firm*—Michael A. Springs;
Covington & Burling

(57) **CLAIM**

The ornamental design for a display apparatus, as shown and described.

DESCRIPTION

FIG. 1 is a perspective view of a display apparatus showing our new design;

FIG. 2 is a rear elevational view thereof;

FIG. 3 is a front elevational view thereof;

FIG. 4 is a right elevational view thereof;

FIG. 5 is a left elevational view thereof;

FIG. 6 is a top plan view thereof;

FIG. 7 is a bottom plan view thereof;

FIG. 8 is a perspective view of an alternative embodiment of a display apparatus showing our new design;

FIG. 9 is a rear elevational view thereof;

FIG. 10 is a front elevational view thereof;

FIG. 11 is a left elevational view thereof;

FIG. 12 is a right elevational view thereof;

FIG. 13 is a top plan view thereof; and,

FIG. 14 is a bottom plan view thereof.

The broken line showing of the base is for illustrative purposes only and forms no part of the claimed design.

1 Claim, 14 Drawing Sheets

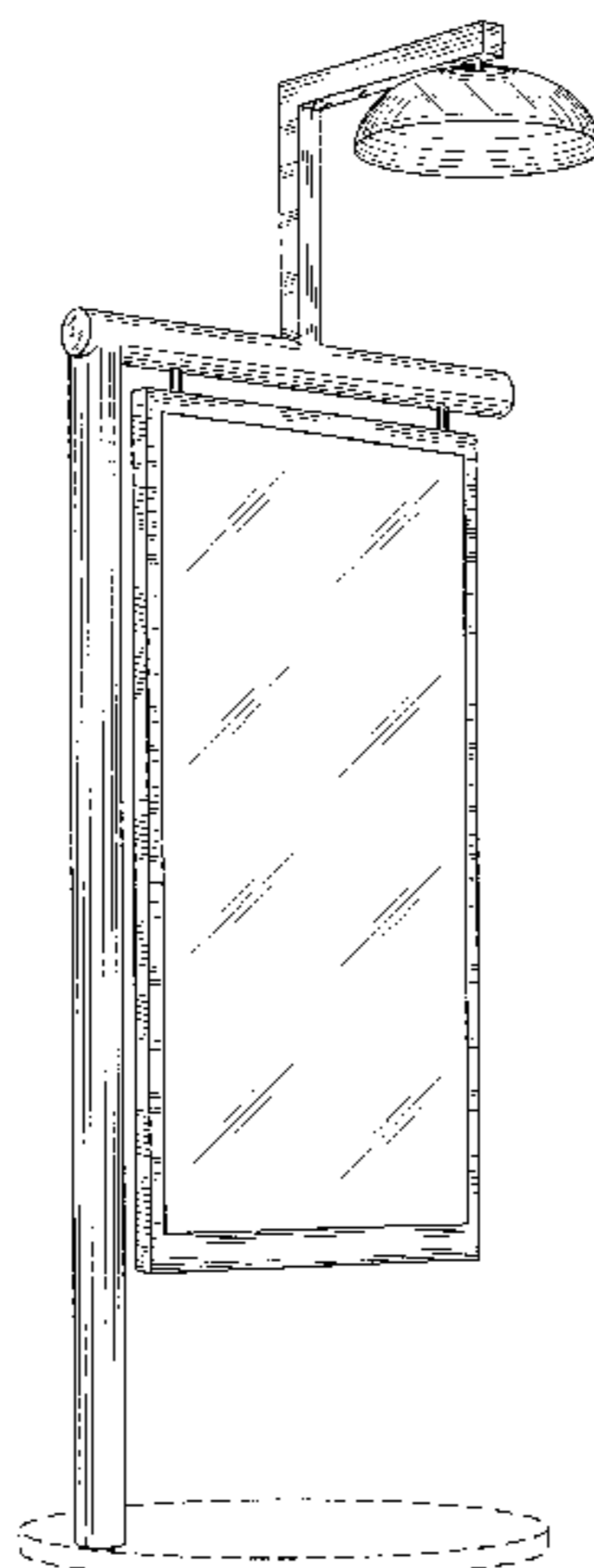

OTHER PUBLICATIONS

Stock, H., "Coming Next to Your Local Bank: ATM's That Allow Internet Access?" American Banker, Mar. 9, 2000, vol. 165, No. 47, p. 20A.

Anon., "The Year of the Thin Client," Cards International, Dec. 11, 1996, vol. 169, p. 7.

Edwards, R., "ATMs—the Hot New Media Buy," ABA Banking Journal, Mar. 1999, vol. 91, No. 3, pp. 58–60.

Anon., "Drilling for Customer Data on ATMs Made Easier," Bank Network News, Jun. 9, 1999.

Redman, R., "Wells Fargo to Web-enable 6,300 Machines," Bank Systems and Technology, Jul. 2000, vol. 37, No. 7, pp. 18.

Anon., "ATM Prospectors See Data Mining Gold," Bank Network News.

* cited by examiner

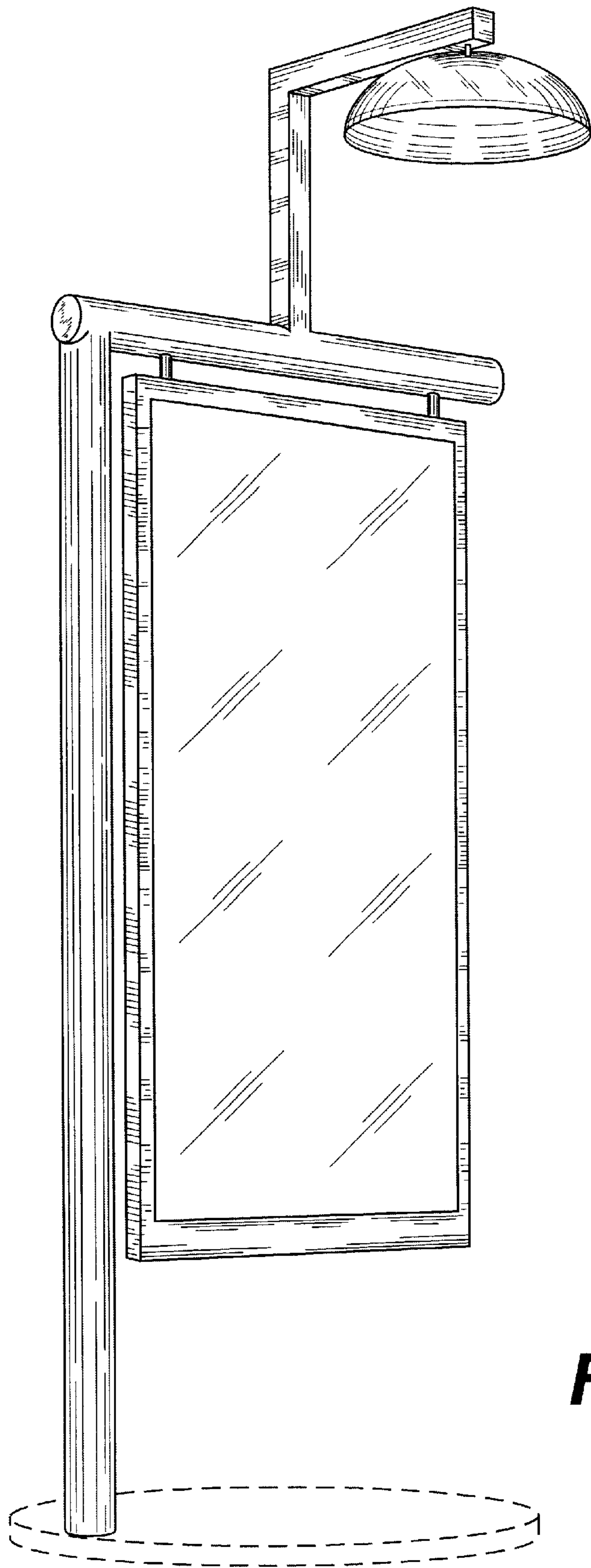

FIG. 1

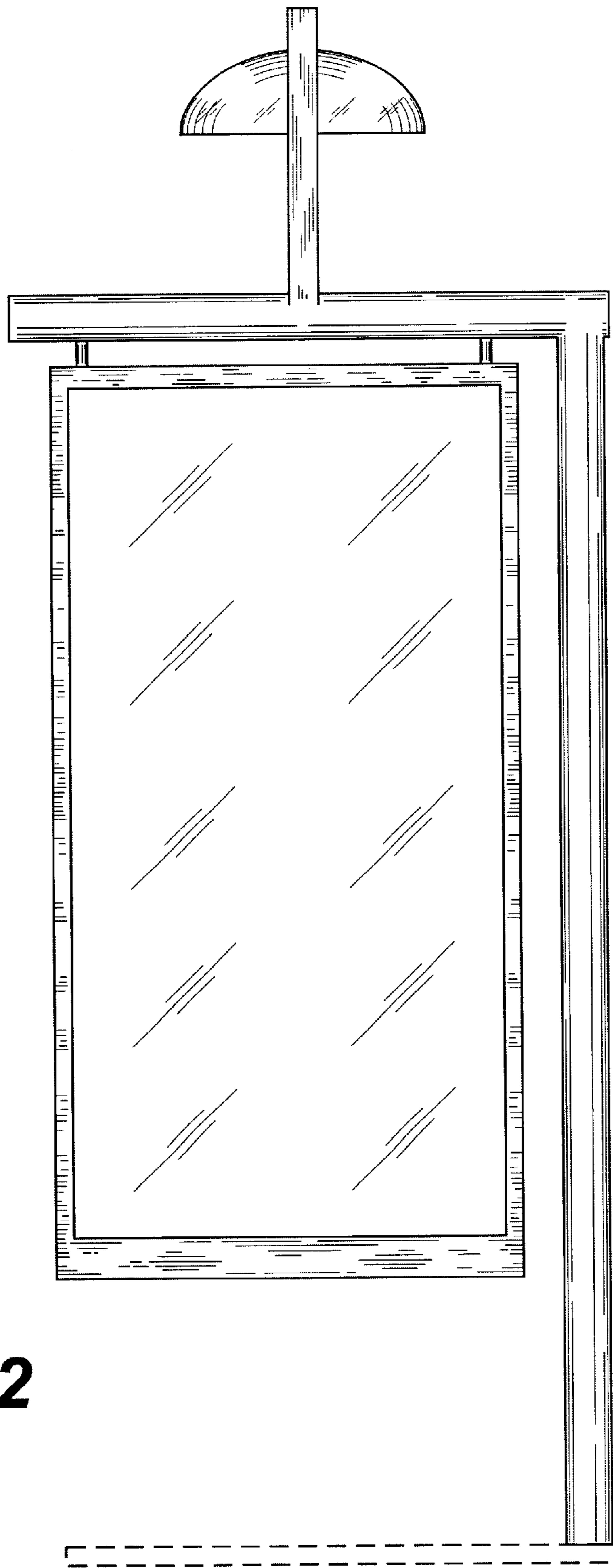

FIG. 2

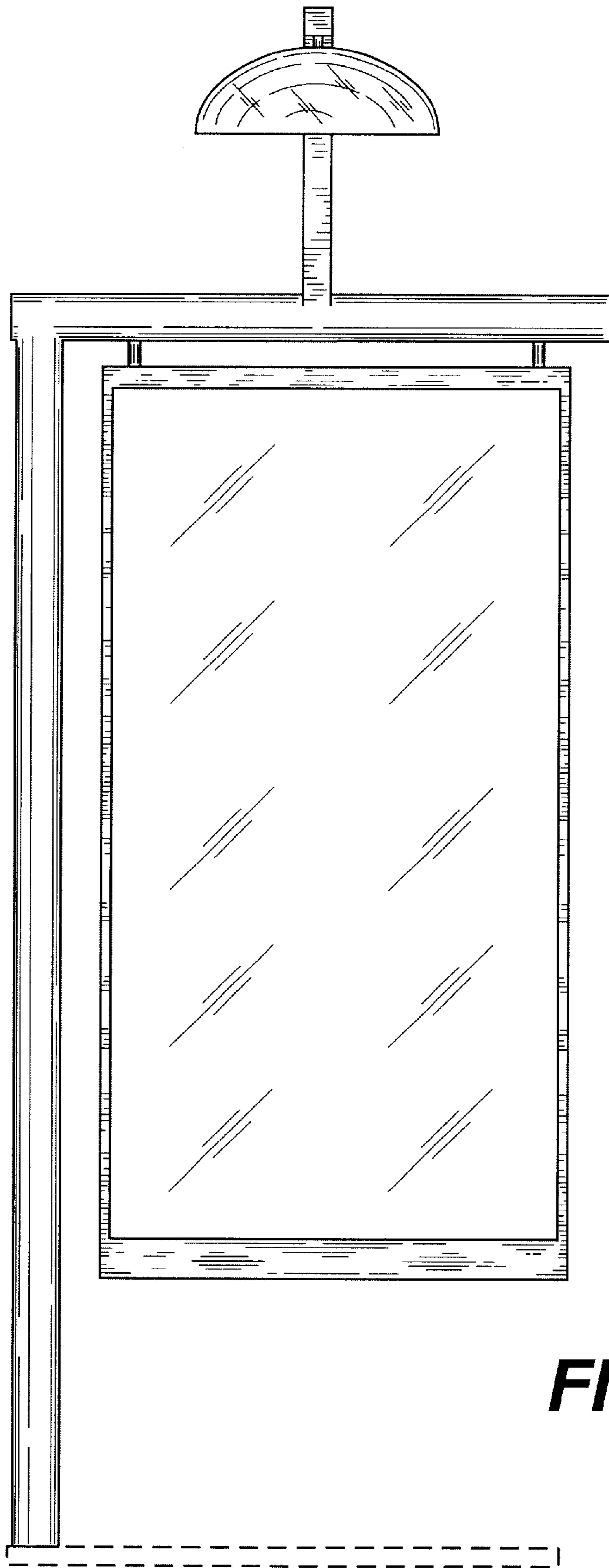

FIG. 3

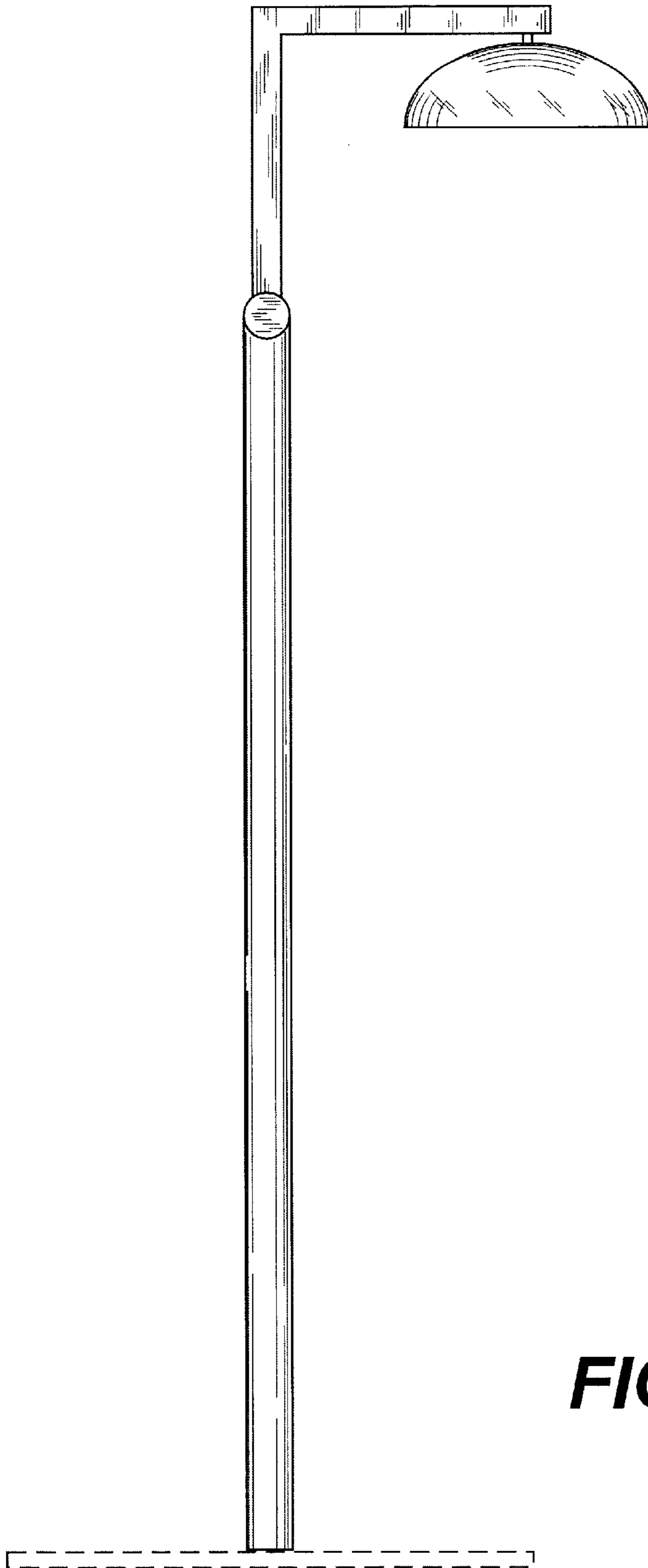

FIG. 4

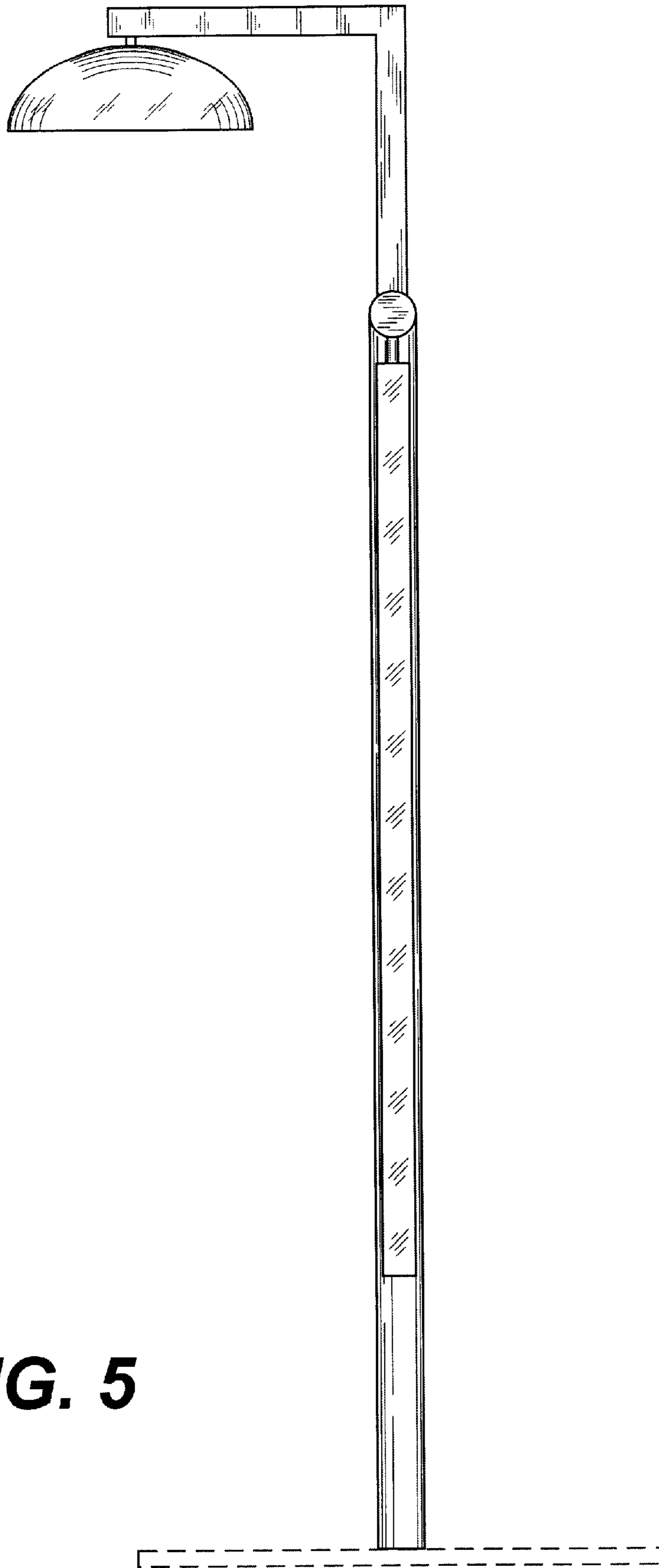

FIG. 5

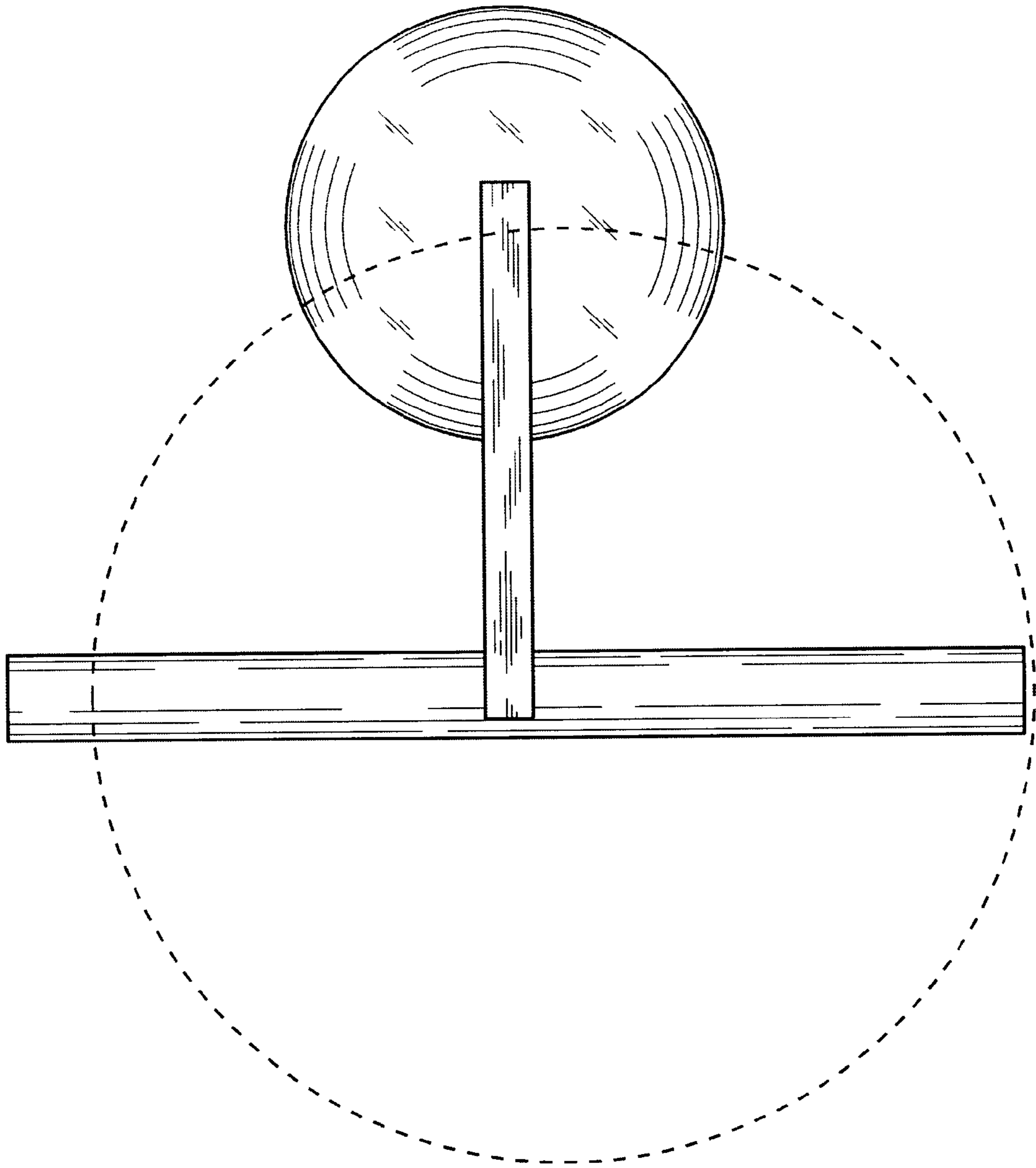

FIG. 6

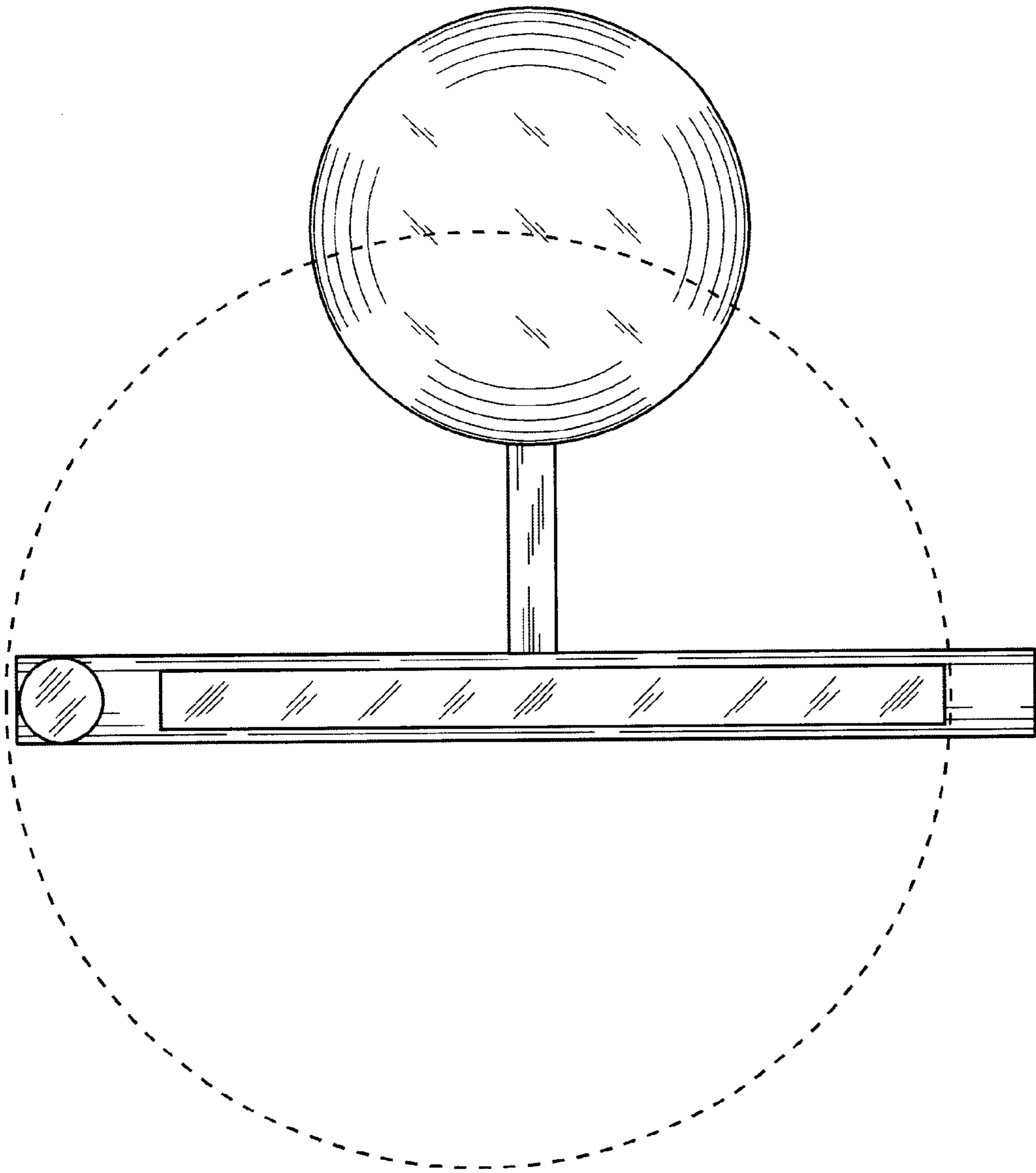

FIG. 7

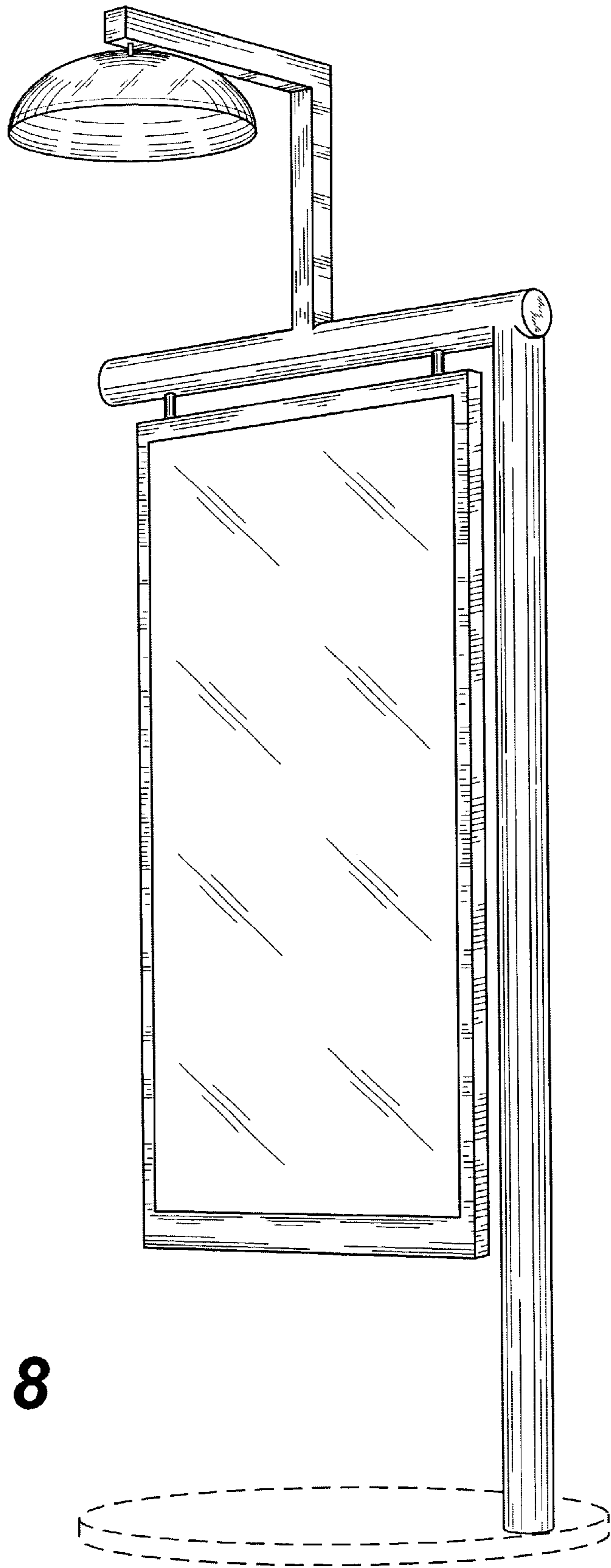

FIG. 8

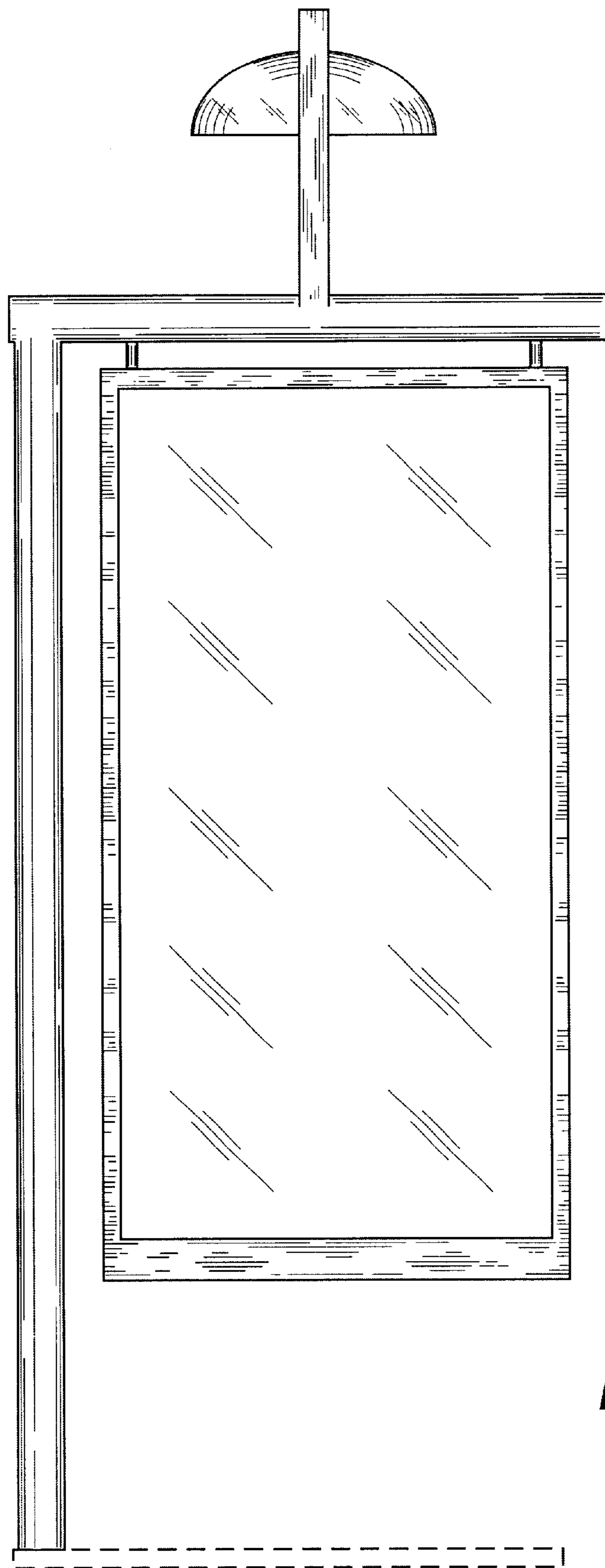

FIG. 9

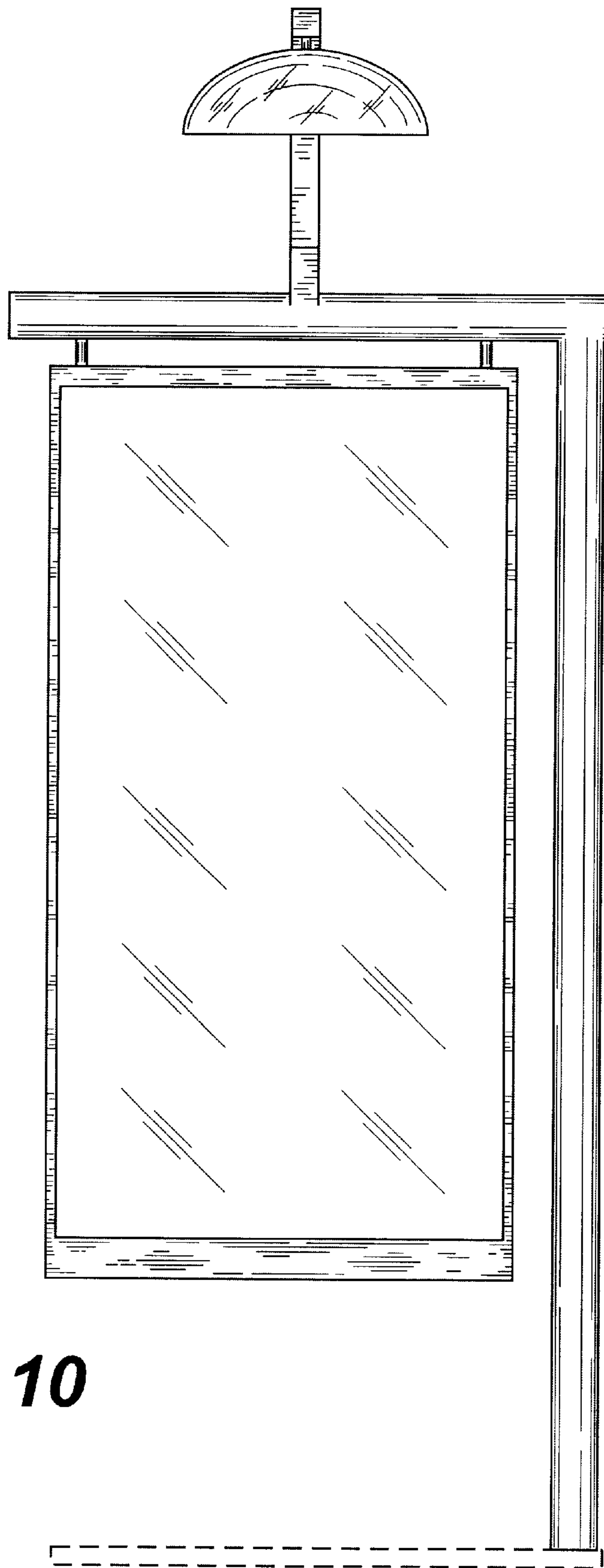

FIG. 10

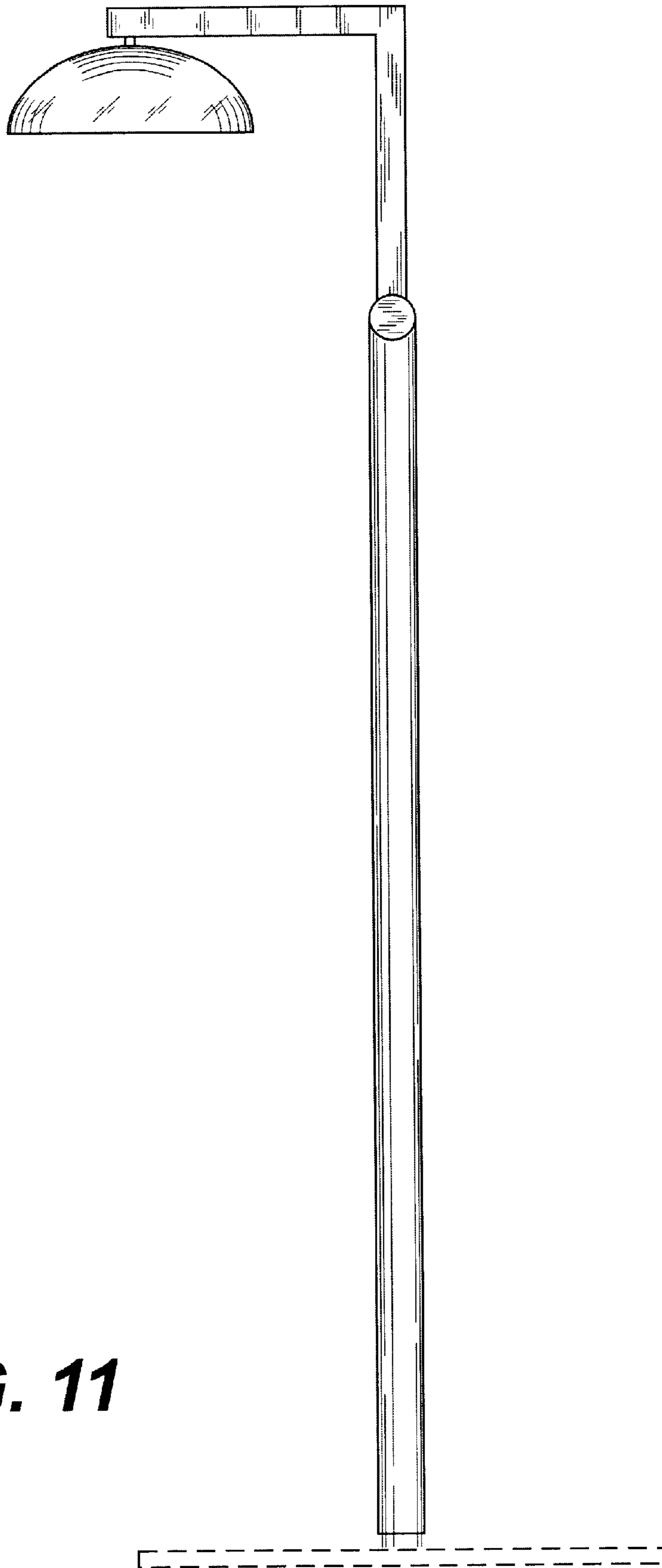

FIG. 11

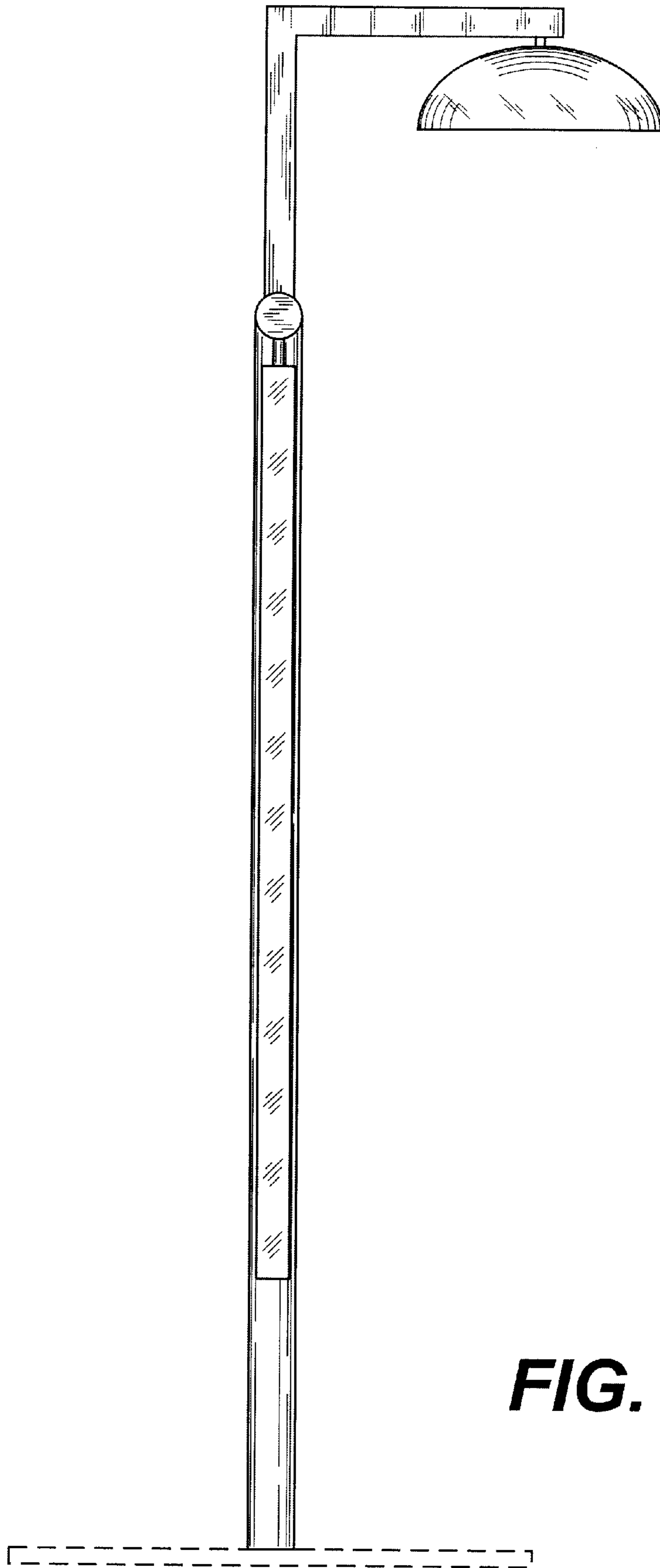

FIG. 12

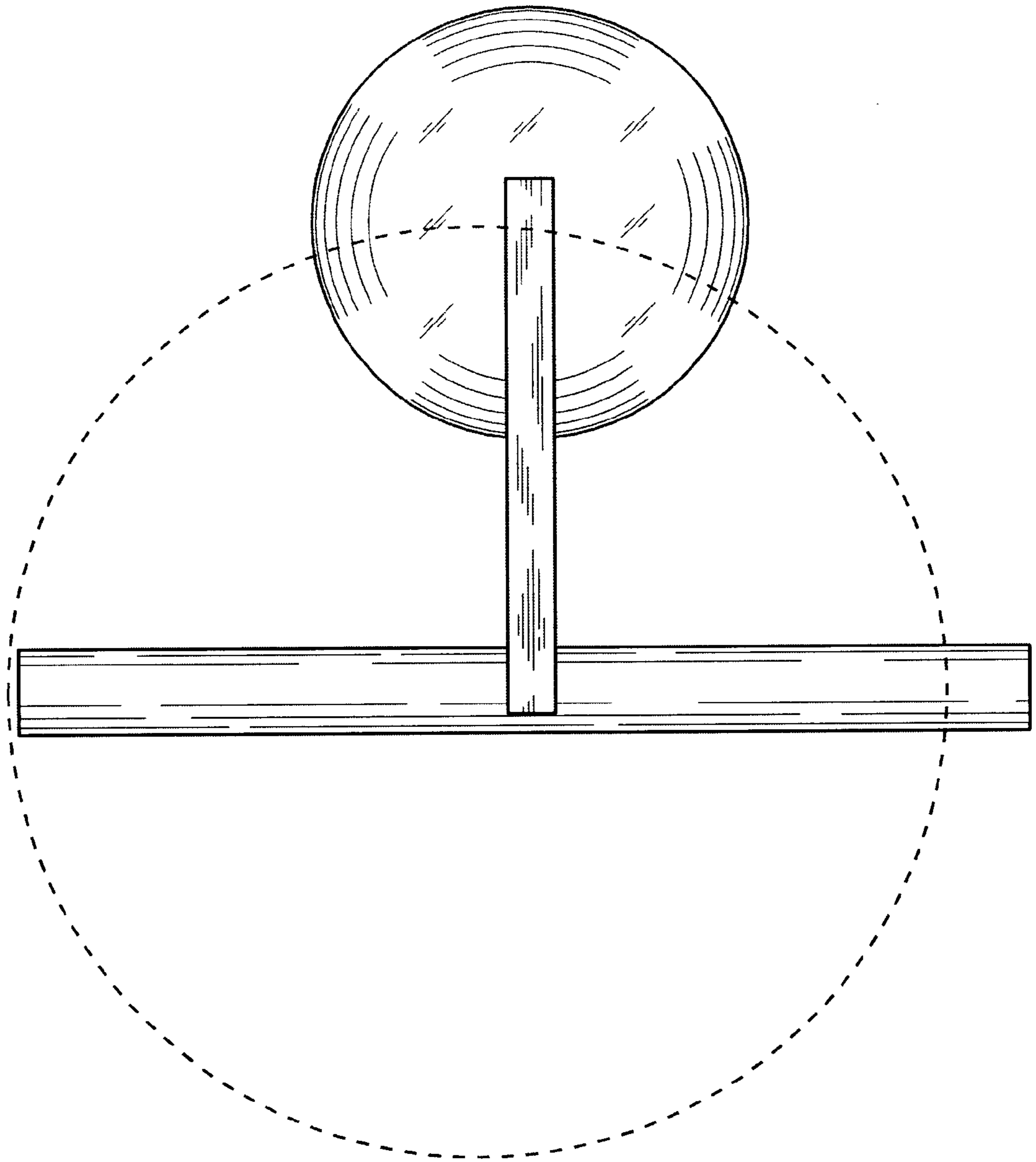

FIG. 13

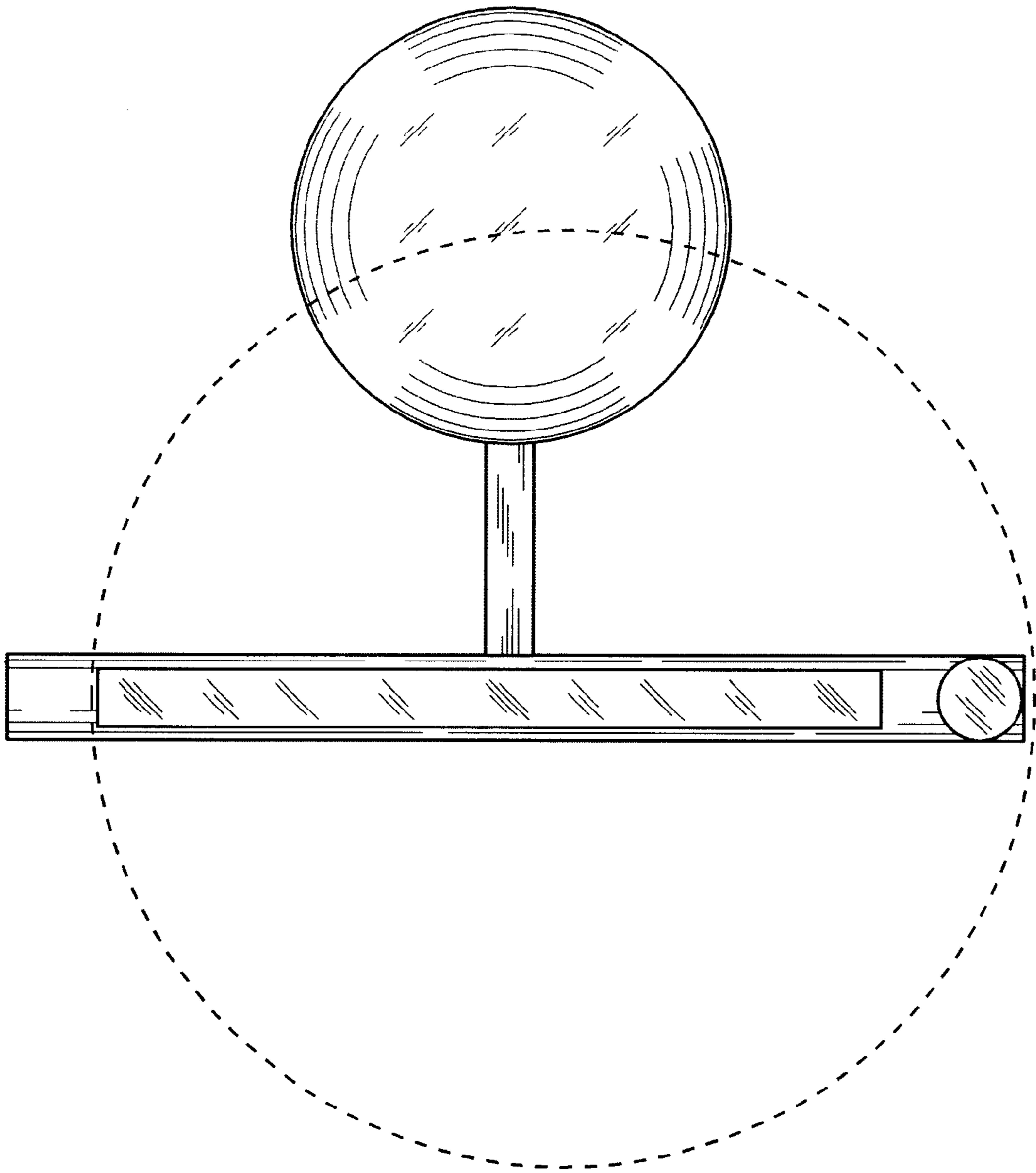

FIG. 14