



US00D479734S

(12) **United States Design Patent**
Schaffer et al.

(10) **Patent No.:** **US D479,734 S**

(45) **Date of Patent:** **** Sep. 16, 2003**

(54) **SURFACE CONFIGURATION OF A SCOOTER**

6,481,728 B2 * 11/2002 Chen 280/87.041
D471,597 S * 3/2003 Chen D21/423
D471,598 S * 3/2003 Chen D21/423

(75) Inventors: **Laurenz Schaffer**, Munich (DE);
Ulrike Graf, Munich (DE)

* cited by examiner

(73) Assignee: **Bayerische Motoren Werke Aktiengesellschaft**, Munich (DE)

Primary Examiner—Raphael Barkai

(74) *Attorney, Agent, or Firm*—Crowell & Moring LLP

(**) Term: **14 Years**

(57) **CLAIM**

(21) Appl. No.: **29/170,134**

The ornamental design for a surface configuration of a scooter, as shown and described.

(22) Filed: **Nov. 1, 2002**

DESCRIPTION

(30) **Foreign Application Priority Data**

May 3, 2002 (DE) 4 02 04 010

(51) **LOC (7) Cl.** **21-01**

(52) **U.S. Cl.** **D21/423**

(58) **Field of Search** D21/423, 419,
D21/421, 425, 424, 426, 435, 533, 760,
765, 771; D12/107, 110–112; 280/87.01,
87.021, 87.041, 87.042; 180/181, 216

FIG. 1 is a front, left perspective view of a surface configuration of a scooter according to our novel design;
FIG. 2 is a rear, left perspective view of the surface configuration of a scooter according to our novel design;
FIG. 3 is a left side view of the surface configuration of a scooter according to our novel design;
FIG. 4 is a right side view of the surface configuration of a scooter according to our novel design;
FIG. 5 is a front view of the surface configuration of a scooter according to our novel design;
FIG. 6 is a rear view of the surface configuration of a scooter according to our novel design; and,
FIG. 7 is a top view of the surface configuration of a scooter according to our novel design.

(56) **References Cited**

U.S. PATENT DOCUMENTS

6,182,988 B1 * 2/2001 Wu 280/87.05
D451,154 S * 11/2001 Navarro D21/423
6,311,998 B1 * 11/2001 Wang et al. 280/87.041
D453,804 S * 2/2002 Robinson D21/423
6,416,060 B1 * 7/2002 Chen 280/87.041

The dash lines included depict environment and are not part of the claimed design.

1 Claim, 5 Drawing Sheets

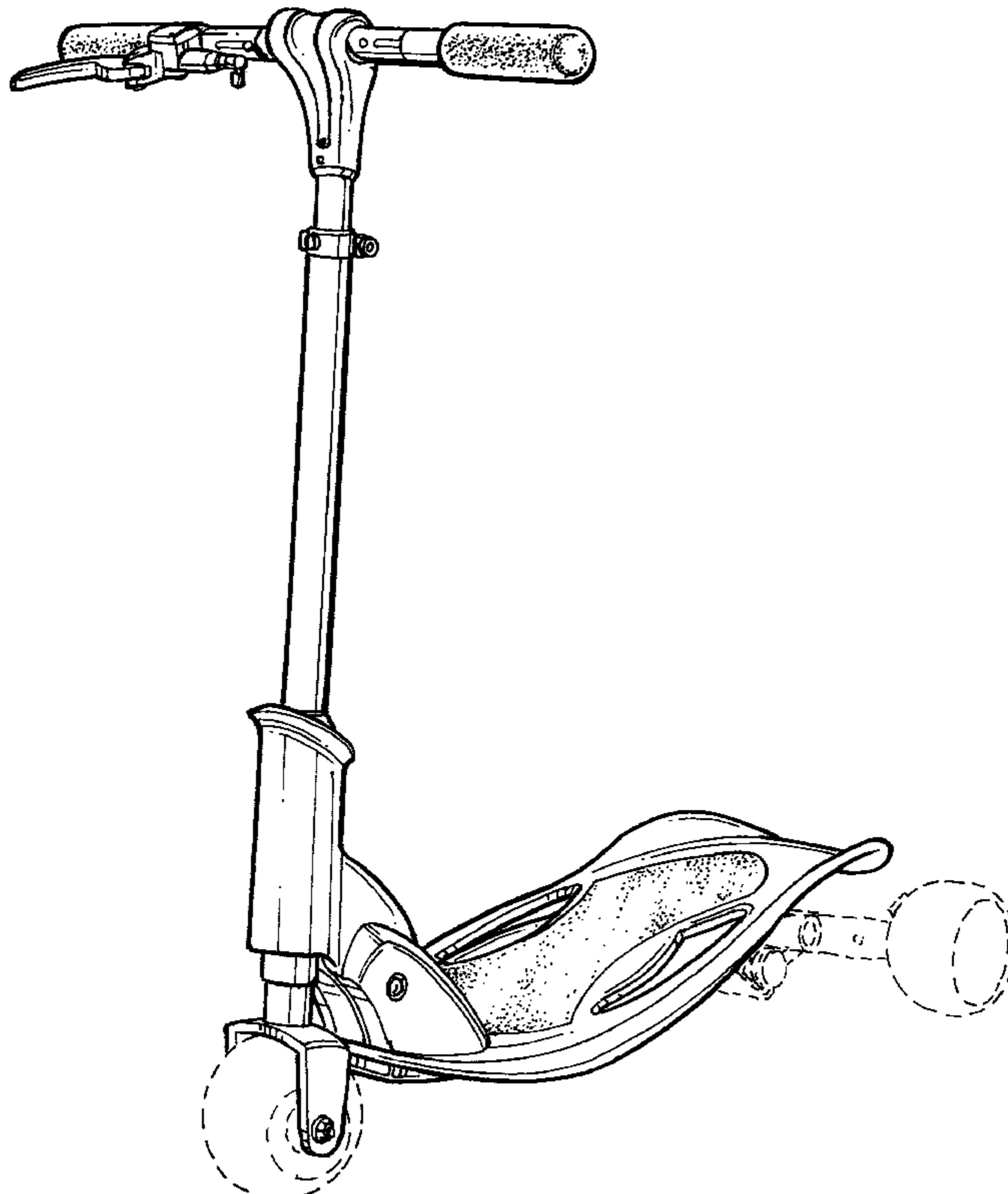

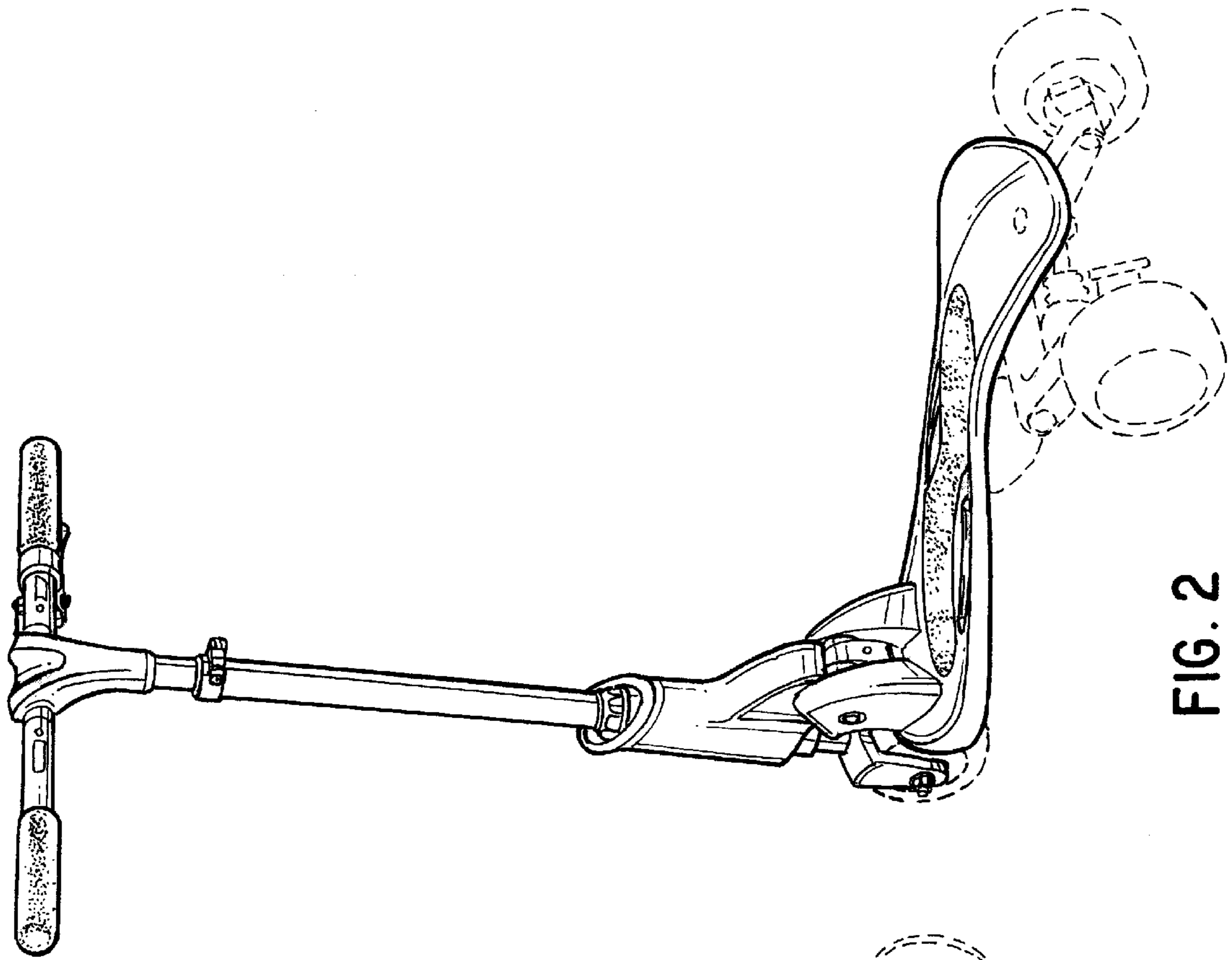

FIG. 2

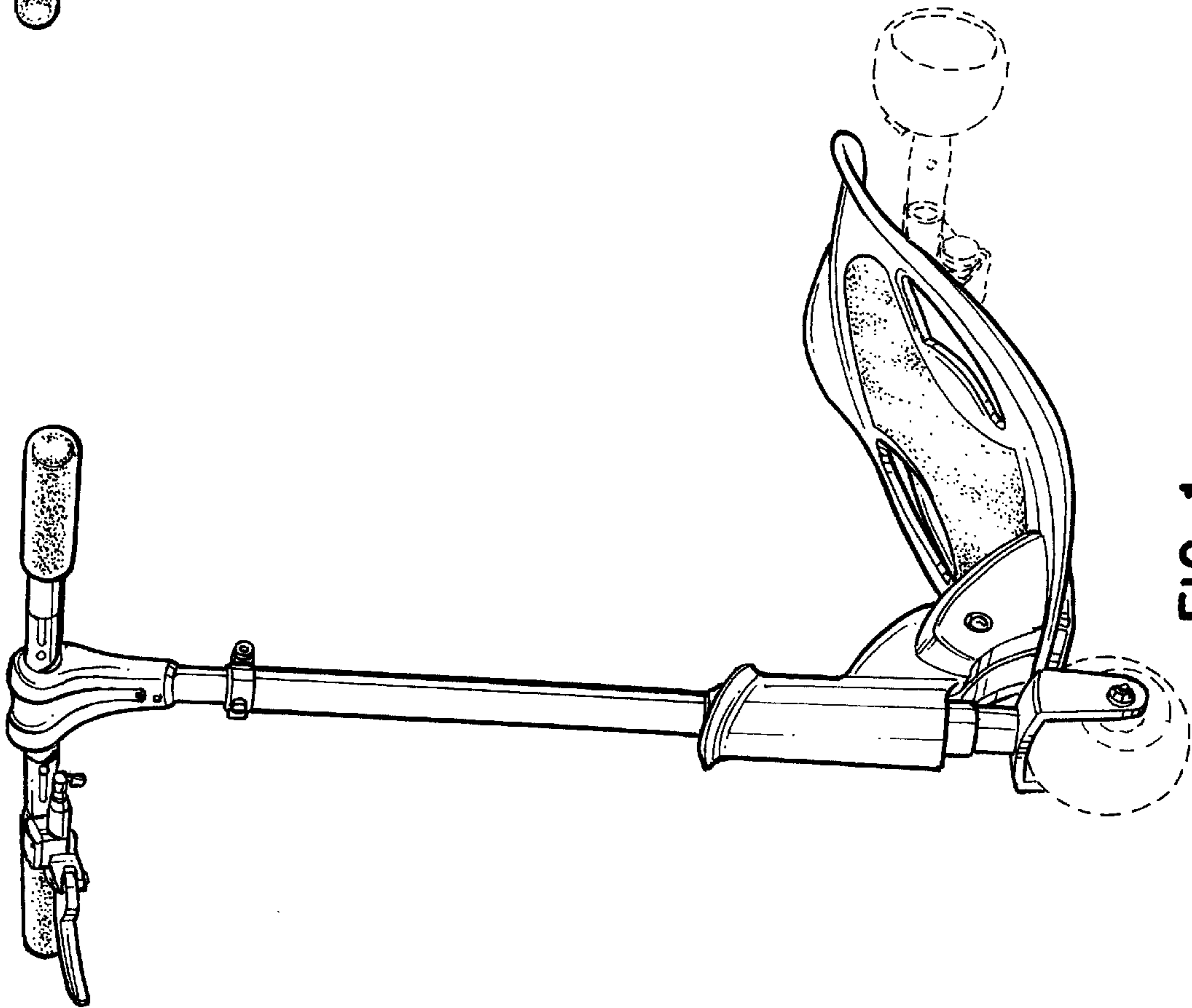

FIG. 1

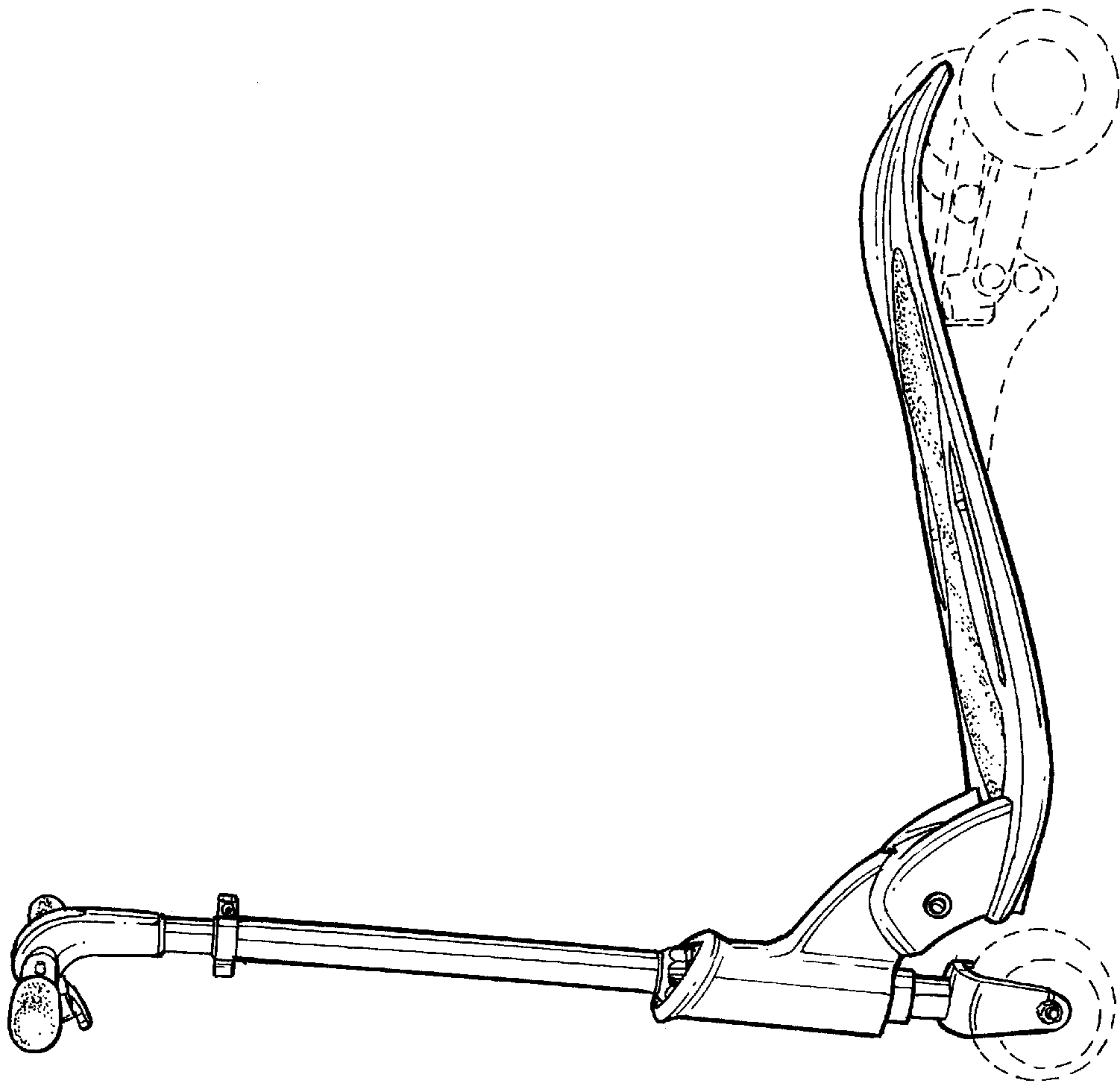

FIG. 3

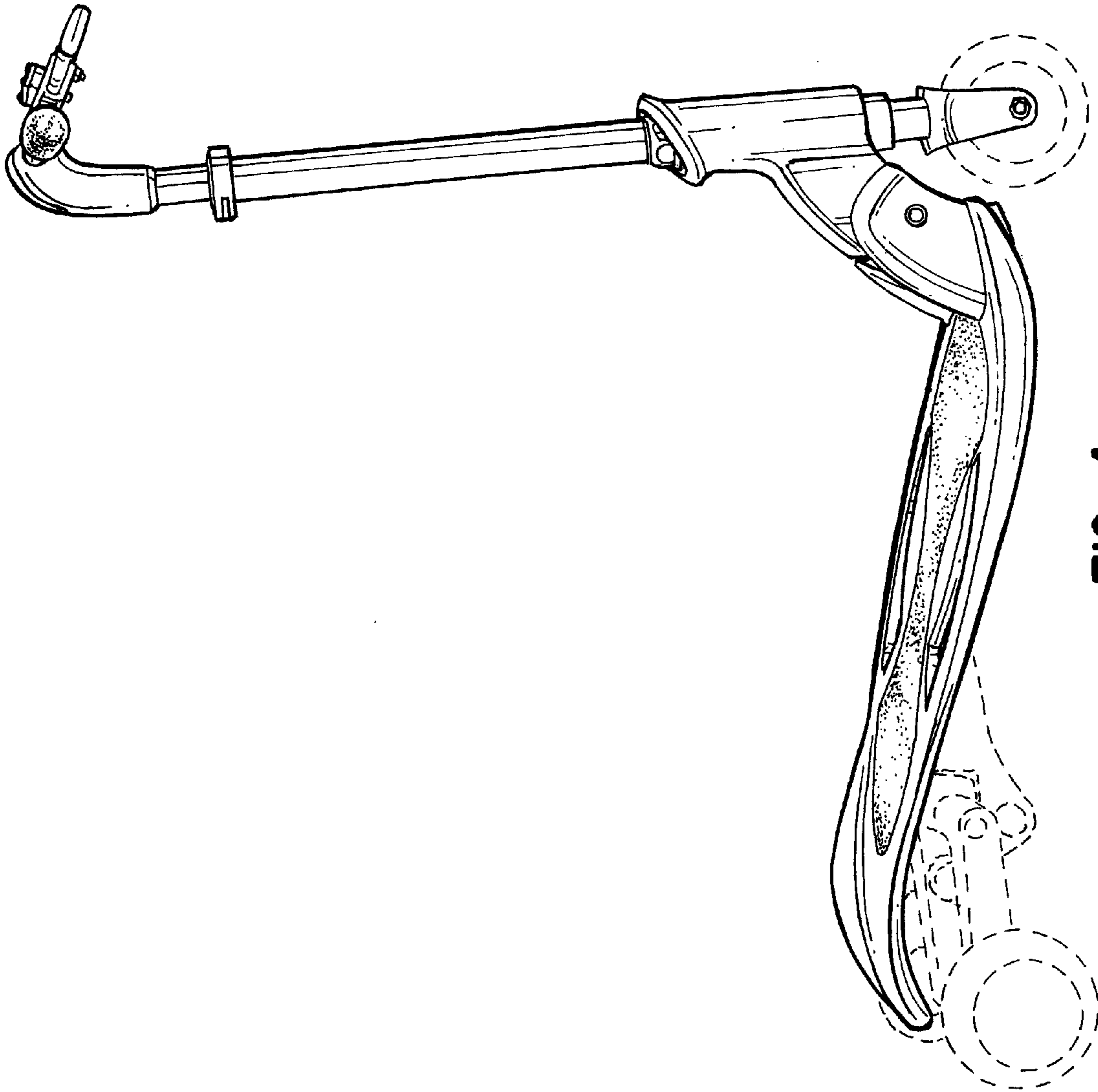

FIG. 4

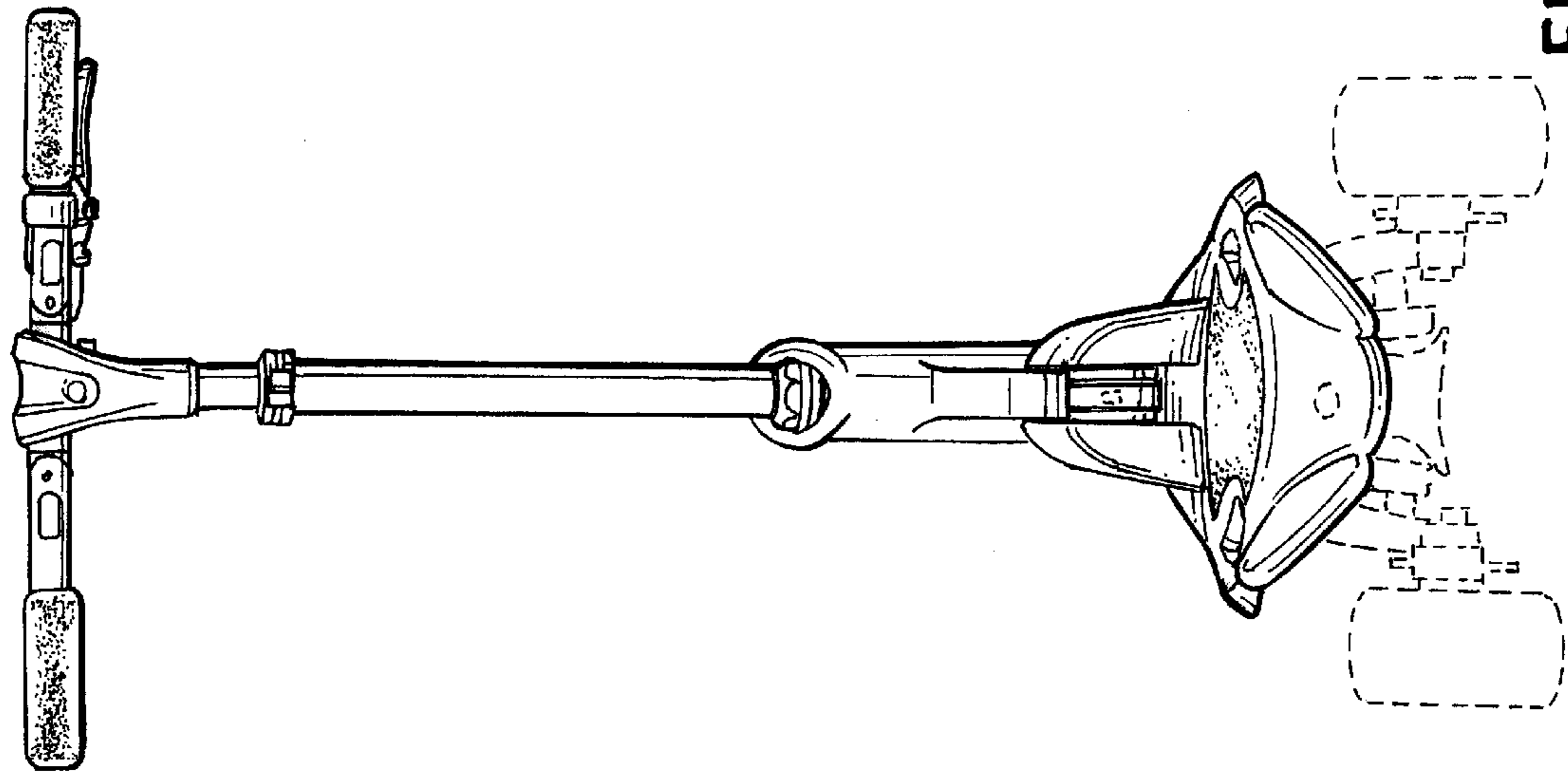

FIG. 5

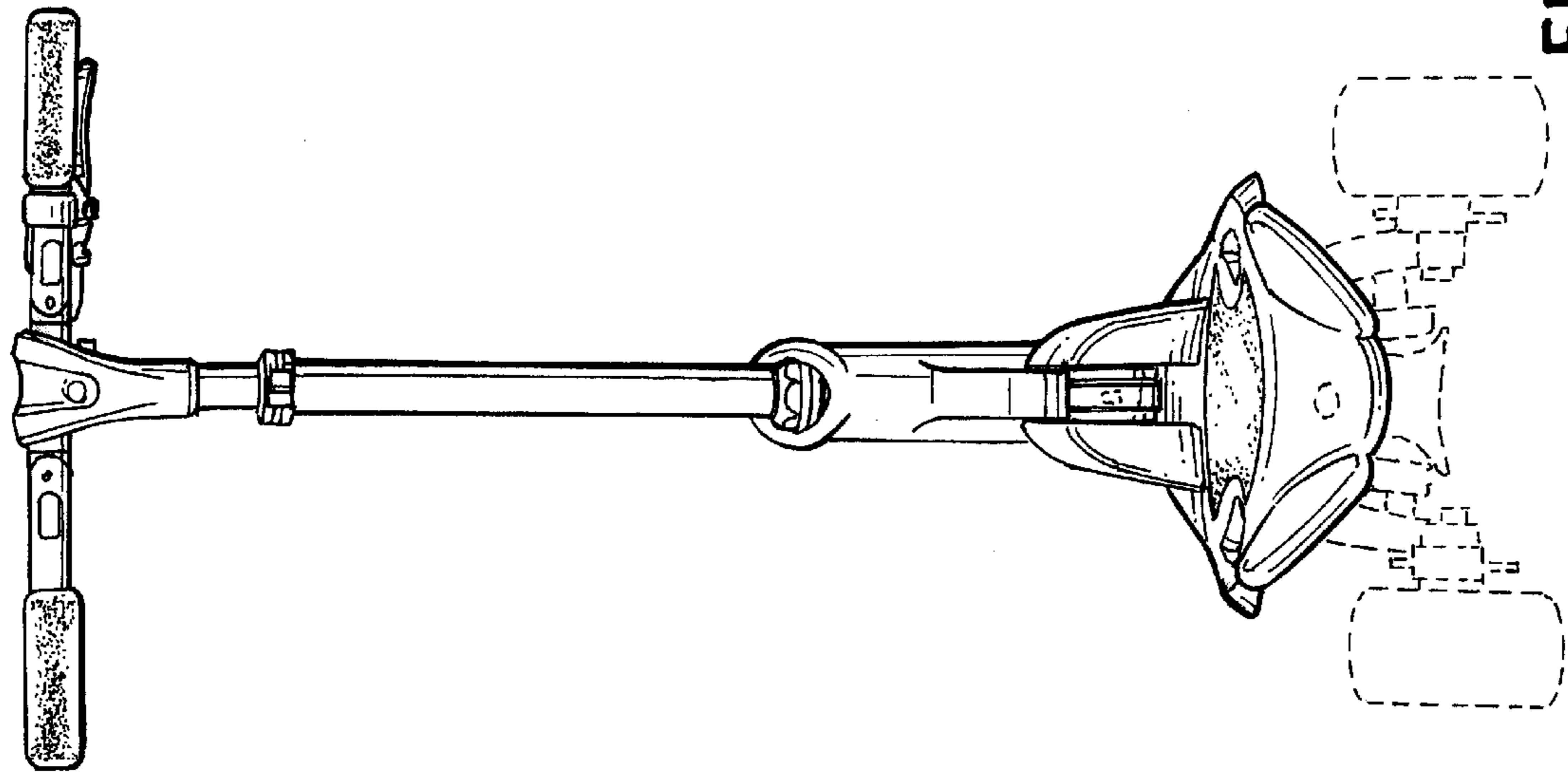

FIG. 6

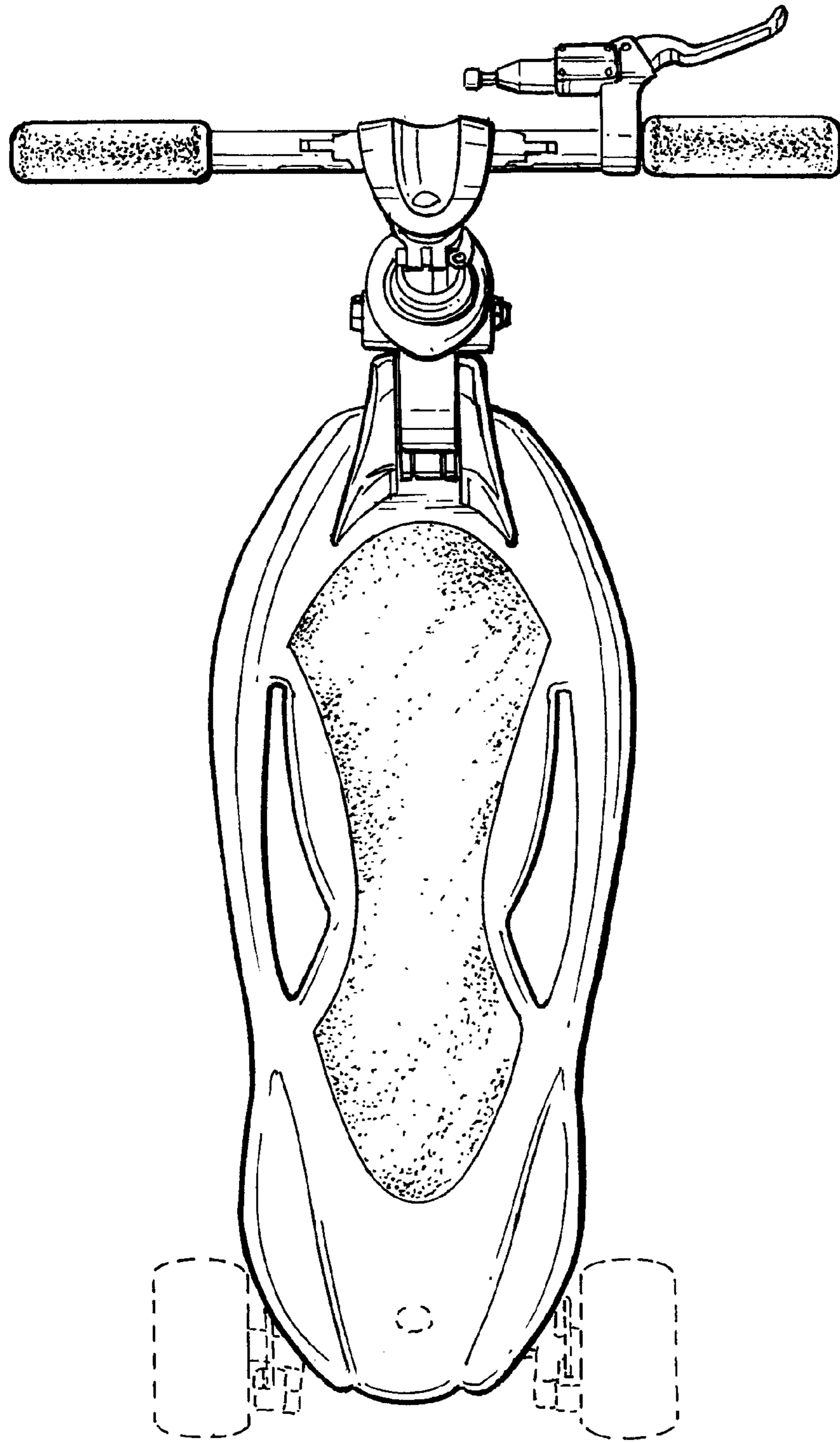

FIG. 7