



US00D479725S

(12) **United States Design Patent**
Lannoch

(10) **Patent No.:** **US D479,725 S**

(45) **Date of Patent:** **** Sep. 16, 2003**

(54) **ANGULAR GEAR**

(75) **Inventor:** **Hans-Jürgen Lannoch,**
Linkenheim-Hochstetten (DE)

(73) **Assignee:** **SEW-Eurodrive GmbH & Co.,**
Bruchsal (DE)

(**) **Term:** **14 Years**

(21) **Appl. No.:** **29/170,184**

(22) **Filed:** **Nov. 1, 2002**

(30) **Foreign Application Priority Data**

May 2, 2002 (DE) 402 03 875

(51) **LOC (7) Cl.** **15-09**

(52) **U.S. Cl.** **D15/148**

(58) **Field of Search** D15/148, 149;
74/409, 606 R, 606 A, 421 A, 416, 417;
118/500, 730; 73/862.338, 862.191

(56) **References Cited**

U.S. PATENT DOCUMENTS

5,408,887	A	*	4/1995	Roth et al.	73/862.338
5,501,117	A		3/1996	Mensing et al.		
D368,919	S		4/1996	Lannoch		
D406,596	S	*	3/1999	Ziegler et al.	D15/148
D410,659	S		6/1999	Lannoch		
D414,790	S		10/1999	Lannoch		
D420,689	S		2/2000	Lannoch		
6,056,826	A	*	5/2000	Rick et al.	118/730
6,234,037	B1	*	5/2001	Zimmer et al.	74/421 A

OTHER PUBLICATIONS

SEW Eurodrive brochure "Low Backlash Planetary Gear Units" Operating Instructions, Edition Mar. 2001.

SEW Eurodrive brochure "Leadership has a Million Reasons: The Complete Program for More Efficiency in Drive Engineering" Program Overview.

SEW Eurodrive Catalog "Low Backlash Planetary Gear Units" Edition Jul. 2002.

SEW Eurodrive brochure Latest News "Precision Planetary Gear Unit PSE" Edition Mar. 2001.

SEW Eurodrive brochure "Antriebstechnik von SEW"—Das komplette Programm auf einen Blick, Edition Mar. 2000.

* cited by examiner

Primary Examiner—Antoine Duval Davis

(74) *Attorney, Agent, or Firm*—Leydig, Voit & Mayer, Ltd.

(57) **CLAIM**

The ornamental design for an angular gear, as described and shown.

DESCRIPTION

FIG. 1 is a perspective view showing my new design of an angular gear;

FIG. 2 is an output front view thereof;

FIG. 3 is a right side view thereof with cover;

FIG. 4 is a left side view thereof with small cover;

FIG. 5 is an input back view thereof;

FIG. 6 is a top view thereof; and,

FIG. 7 is a bottom view thereof.

1 Claim, 7 Drawing Sheets

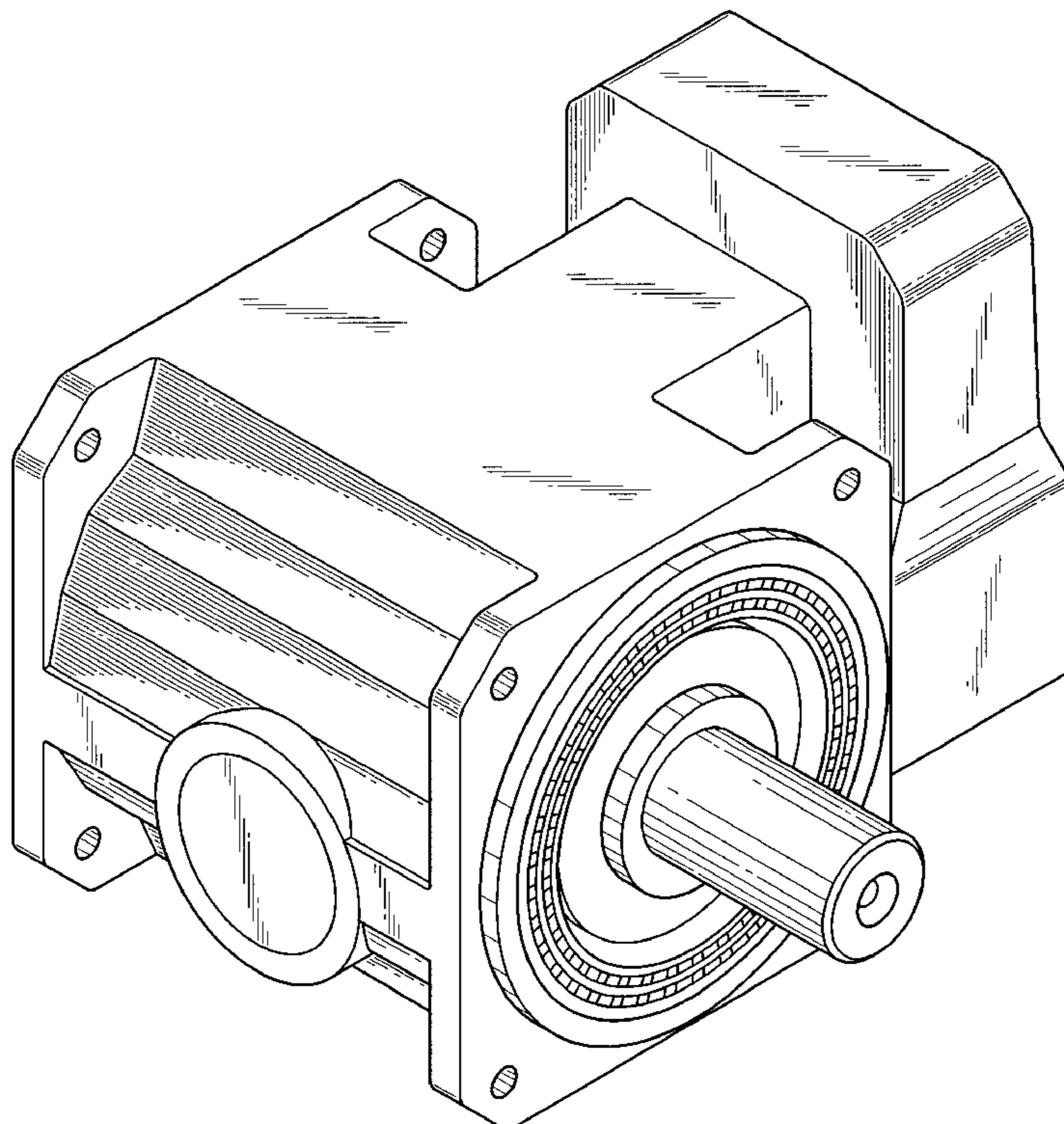

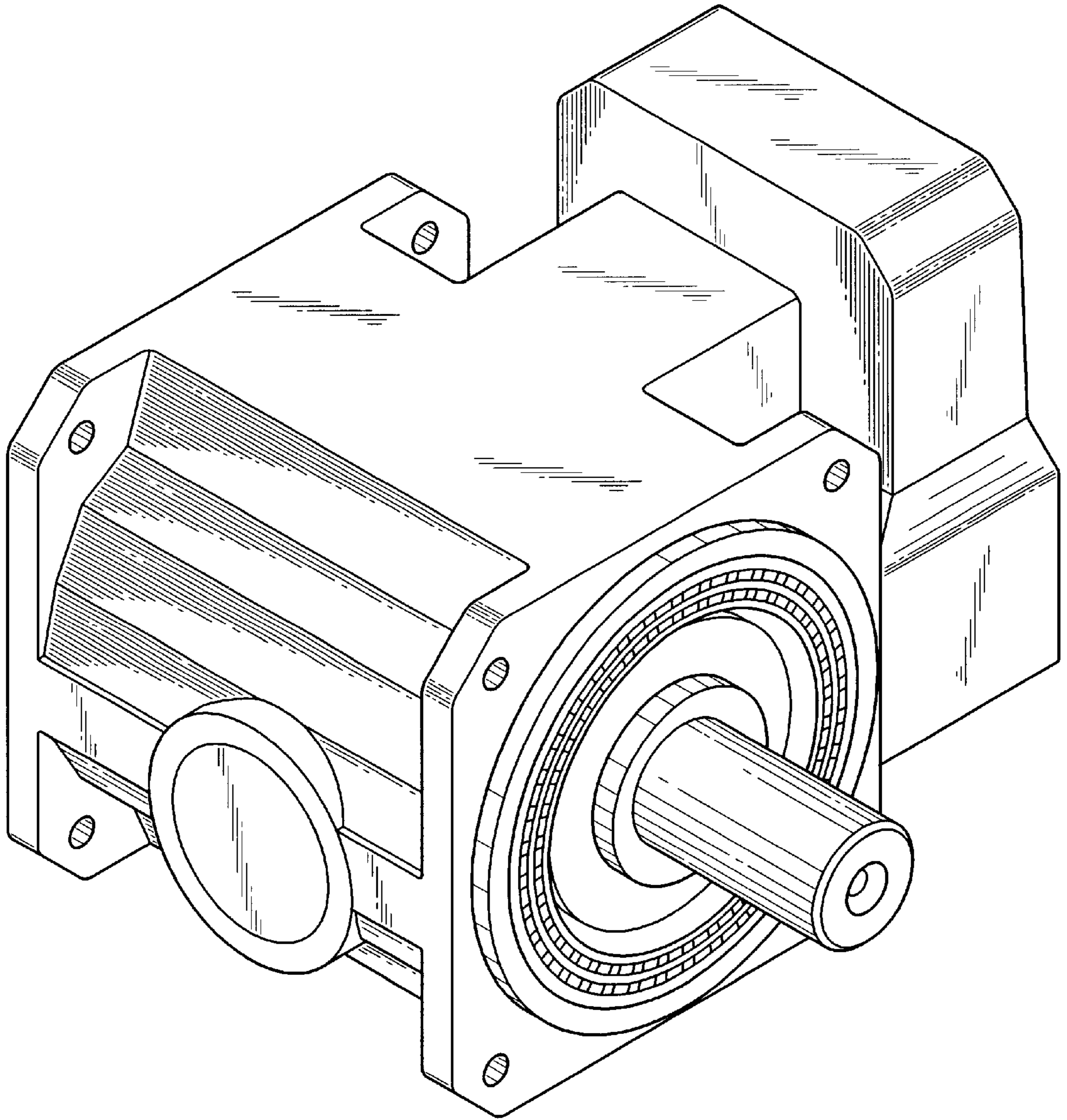

FIG. 1

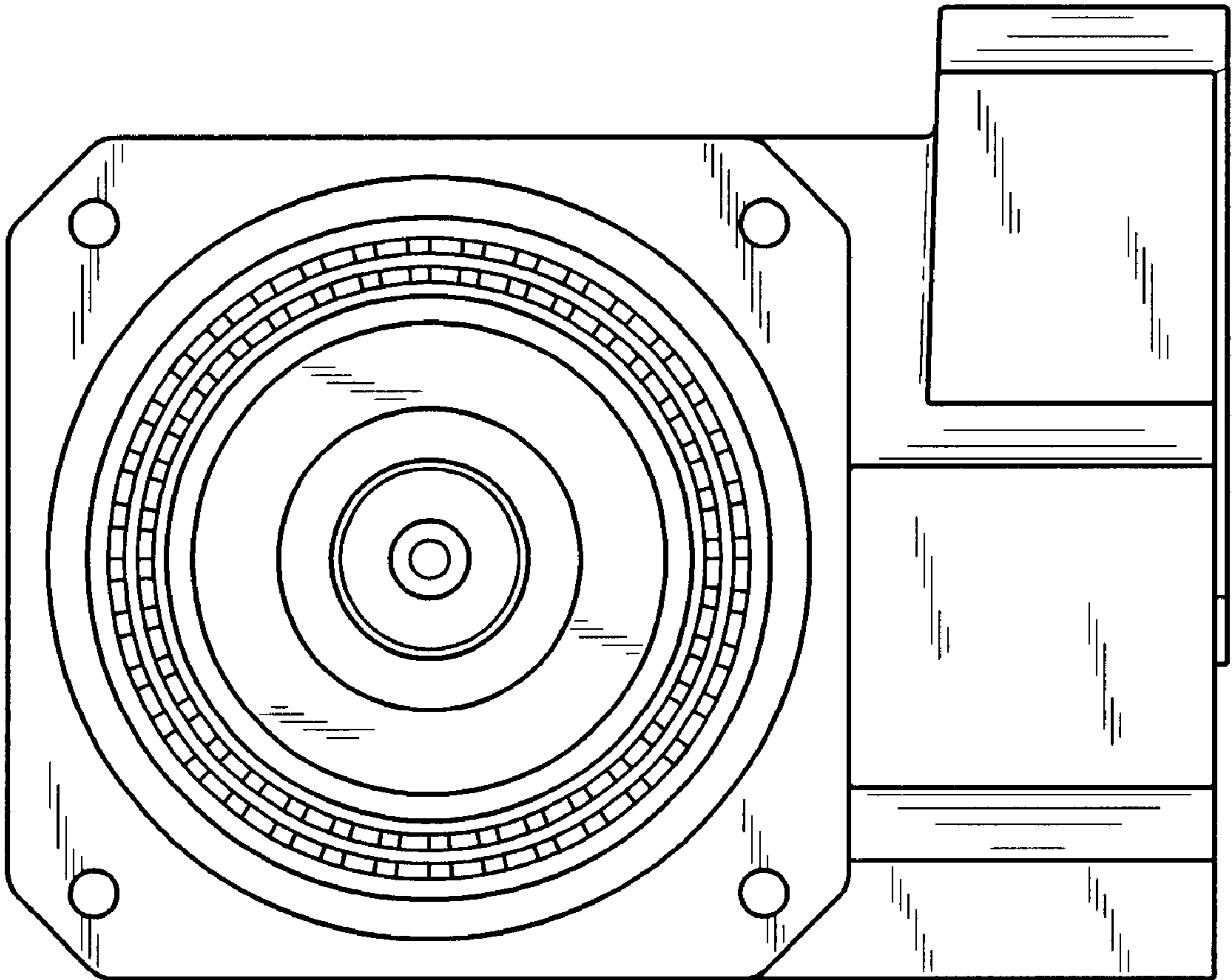

FIG. 2

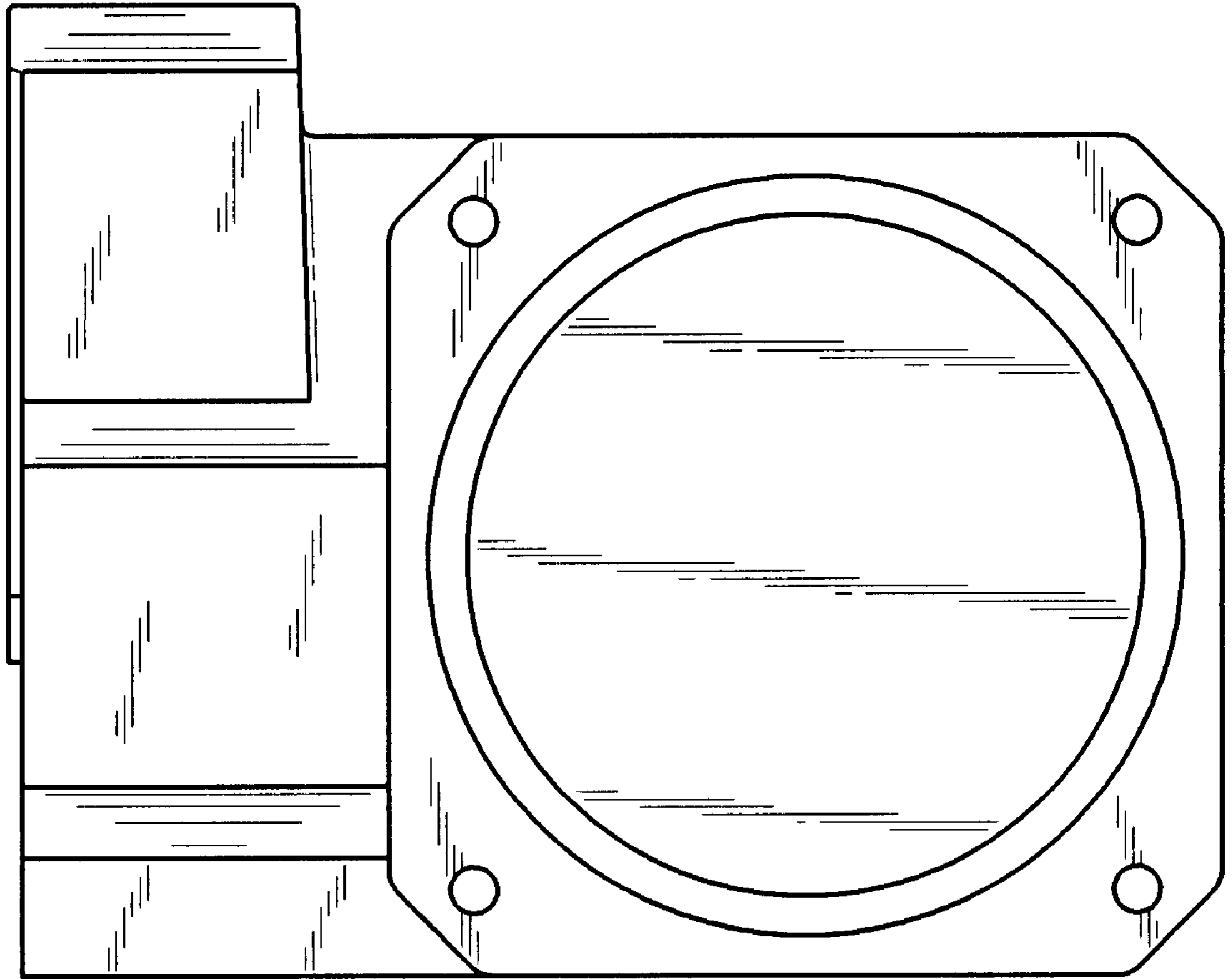

FIG. 3

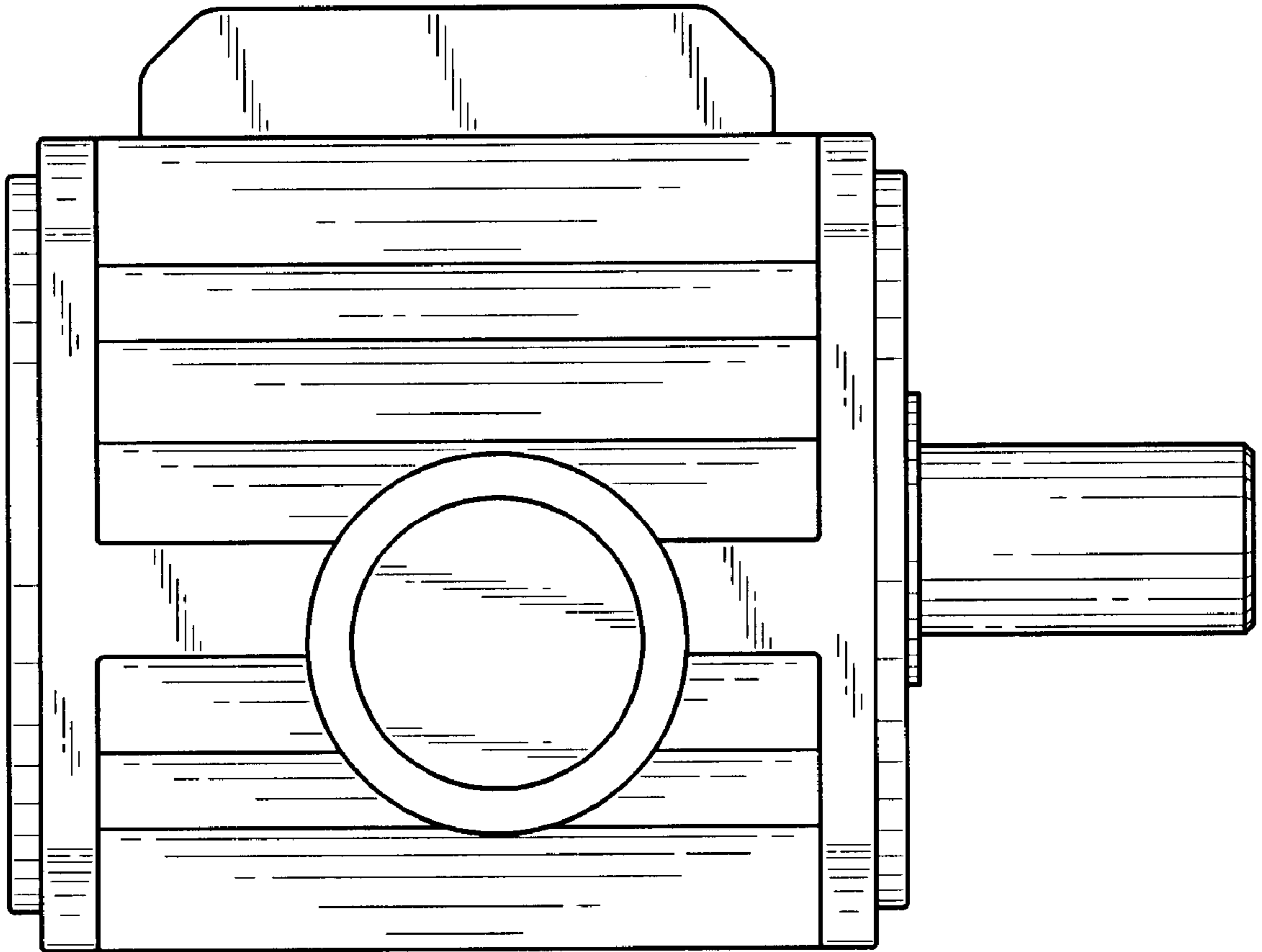

FIG. 4

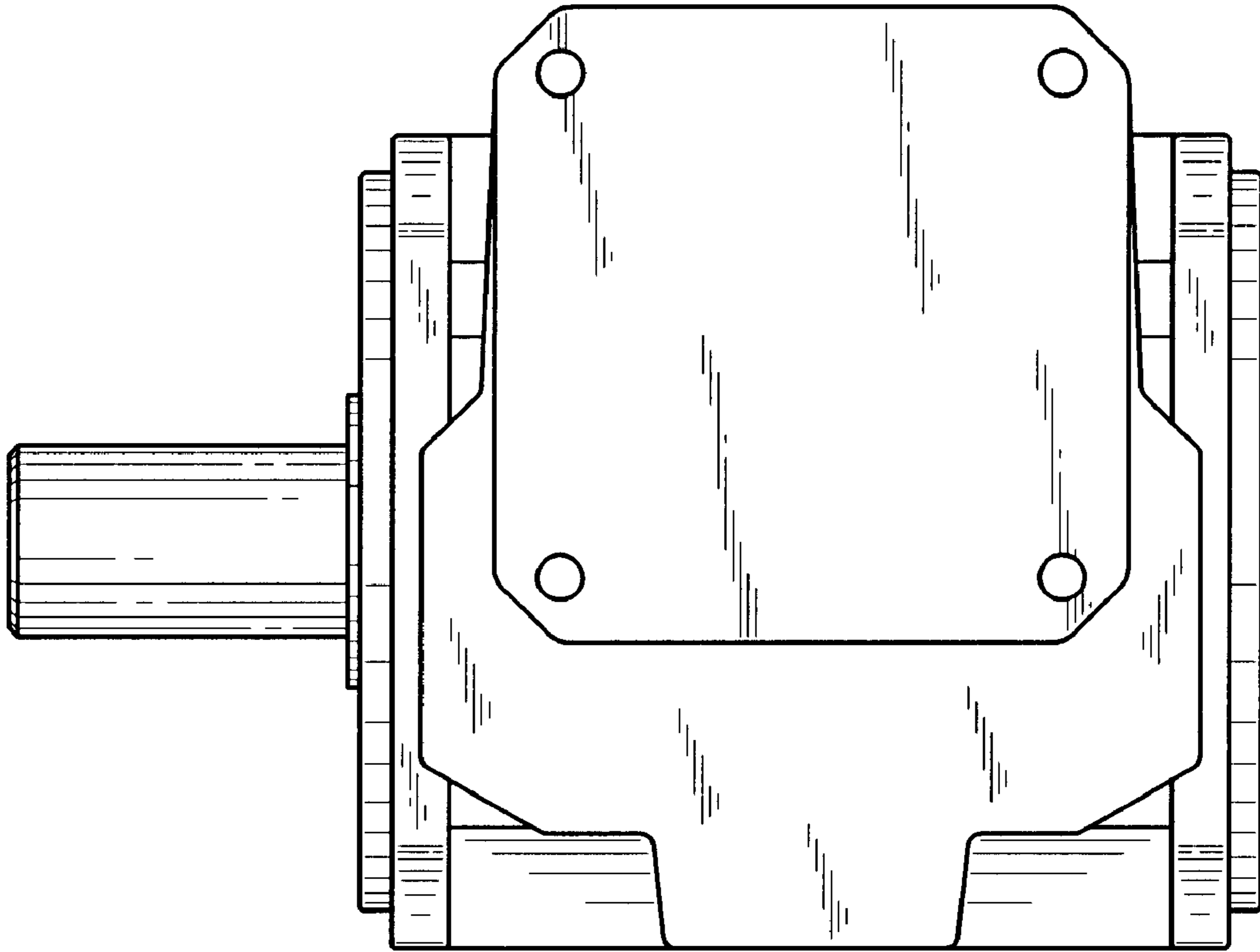

FIG. 5

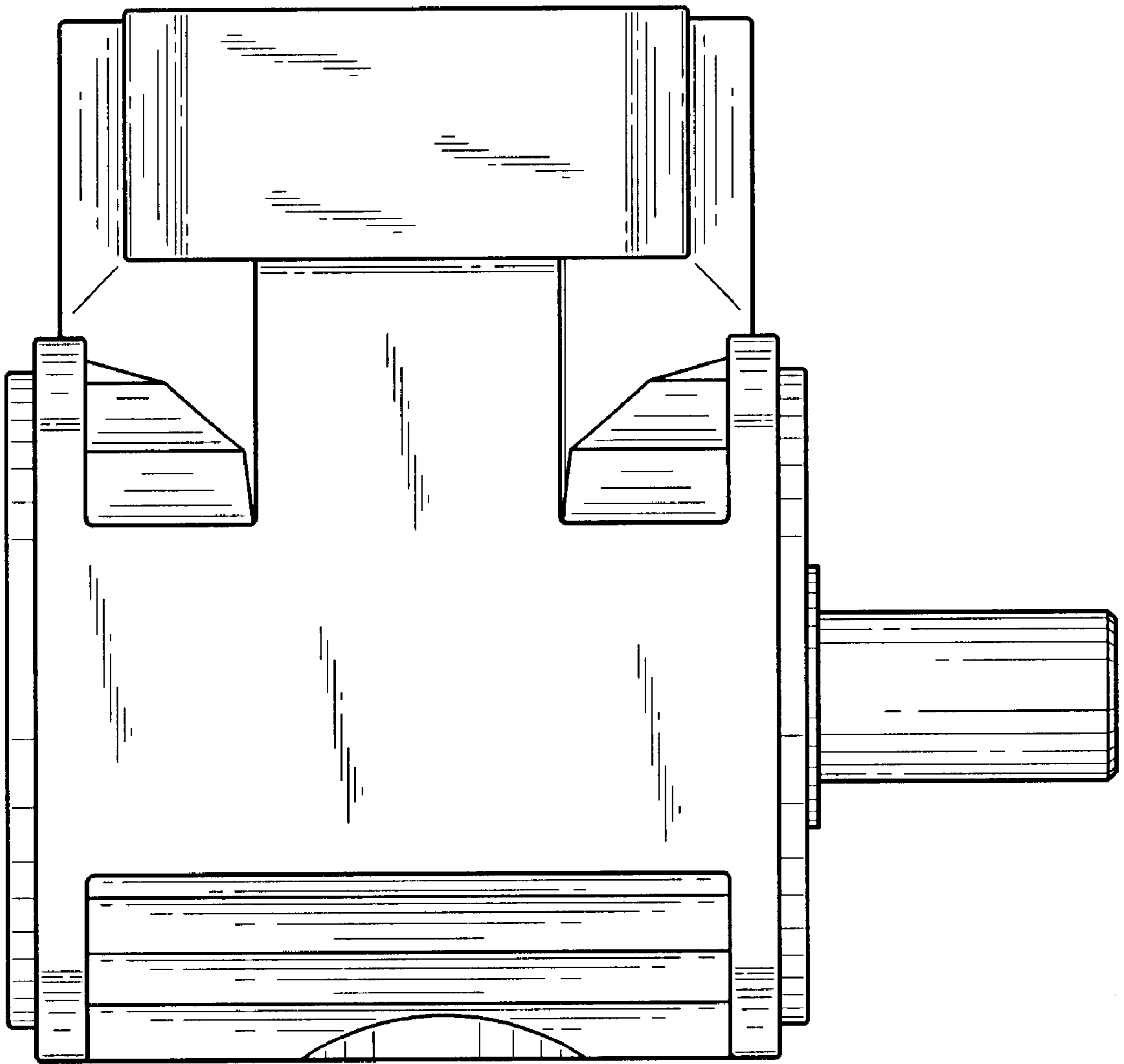

FIG. 6

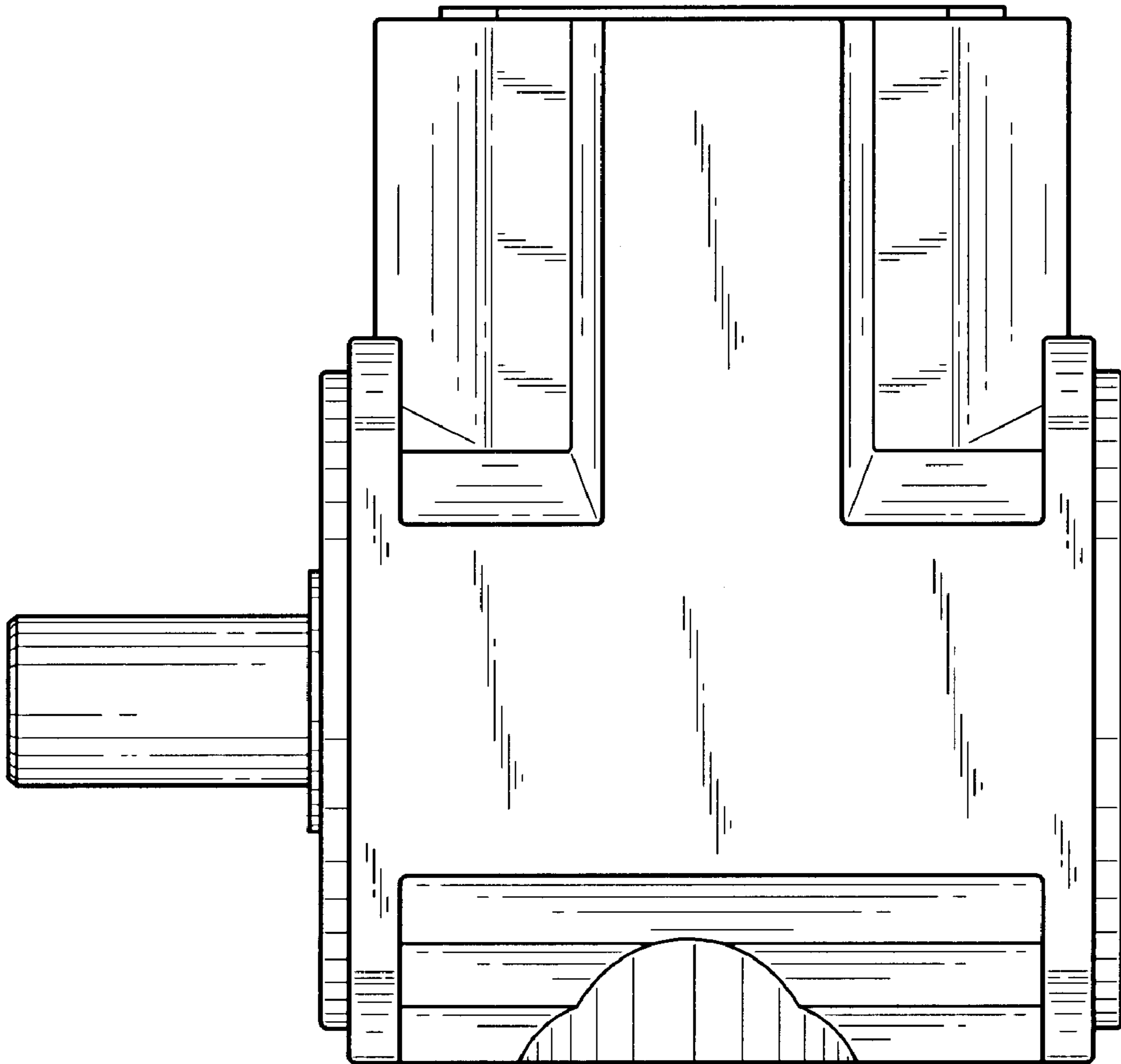

FIG. 7