



US00D479698S

(12) **United States Design Patent**
Cardoso

(10) **Patent No.:** **US D479,698 S**

(45) **Date of Patent:** **** Sep. 16, 2003**

(54) **MOTORCYCLE BOOT GUARD**

(76) Inventor: **Michael Fernandes Cardoso**, 10367
Splendor Ridge Ave., Las Vegas, NV
(US) 89135

(**) Term: **14 Years**

(21) Appl. No.: **29/159,477**

(22) Filed: **Apr. 22, 2002**

(51) **LOC (7) Cl.** **12-11**

(52) **U.S. Cl.** **D12/126**

(58) **Field of Search** D12/110, 114,
D12/126, 190; 280/288.4, 291, 304.3, 304.4;
248/220.1, 225.11; D8/349, 380, 403; 74/564

(56) **References Cited**

U.S. PATENT DOCUMENTS

1,476,592	A	*	12/1923	Carlson	74/564
4,023,821	A	*	5/1977	Eiland	280/291
4,458,910	A	*	7/1984	Stillwagon	280/291
D389,989	S		2/1998	Pilz		
D395,024	S	*	6/1998	Baratti	D12/114
D455,375	S	*	4/2002	Johnson	D12/126

OTHER PUBLICATIONS

Carl Miles, Advertisement for "Miles Ahead" heel guard,
available prior to filing date.
Thunder Press Magazine; West Edition, Mar. 2002, p. 29,
Right col., Bottom.
Thunder Press Magazine; West Edition, Apr. 2002, p. 142,
Lower lefthand col.

Marketing Flier provided by a Motorcycle Dealership
located in Daytona Beach, FL. Feb. 2002.

* cited by examiner

Primary Examiner—Alan P. Douglas
Assistant Examiner—Linda Brooks
(74) *Attorney, Agent, or Firm*—Kenehan & Lambertsen,
Ltd.; John C. Lambertsen

(57) **CLAIM**

I claim the ornamental design for a motorcycle boot guard,
as shown and described.

DESCRIPTION

FIG. 1 is a front perspective view of the first embodiment of
my new design;
FIG. 2 is a left side elevation view thereof;
FIG. 3 is a right side elevation view thereof;
FIG. 4 is a front elevation view thereof;
FIG. 5 is a back elevation view thereof;
FIG. 6 is a top elevation view thereof;
FIG. 7 is a bottom elevation view thereof;
FIG. 8 is a front perspective view of the second embodiment
of my new design;
FIG. 9 is a left side elevation view thereof;
FIG. 10 is a right side elevation view thereof;
FIG. 11 is a front elevation view thereof;
FIG. 12 is a back elevation view thereof;
FIG. 13 is a top elevation view thereof; and,
FIG. 14 is a bottom elevation view thereof.

1 Claim, 4 Drawing Sheets

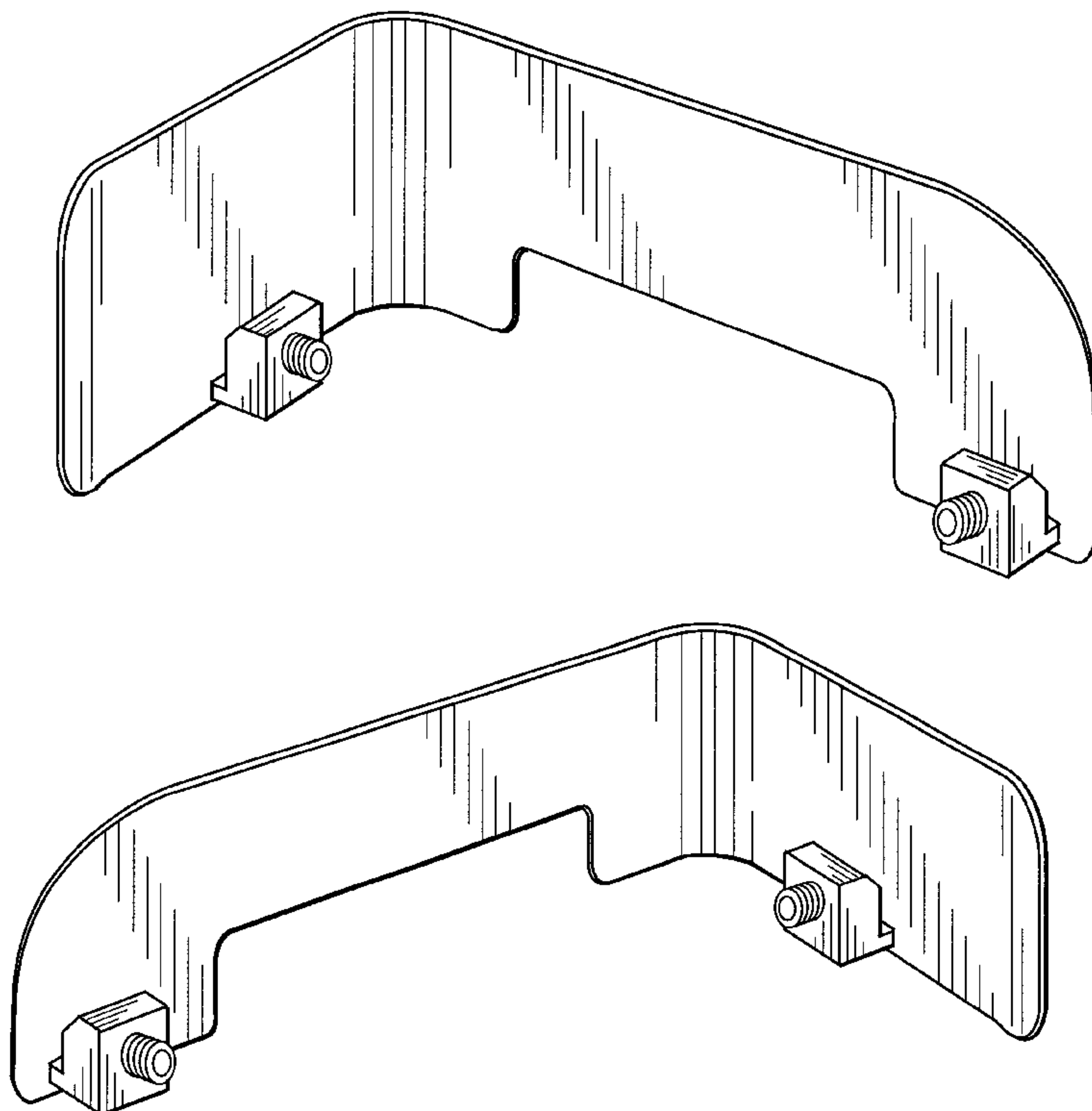

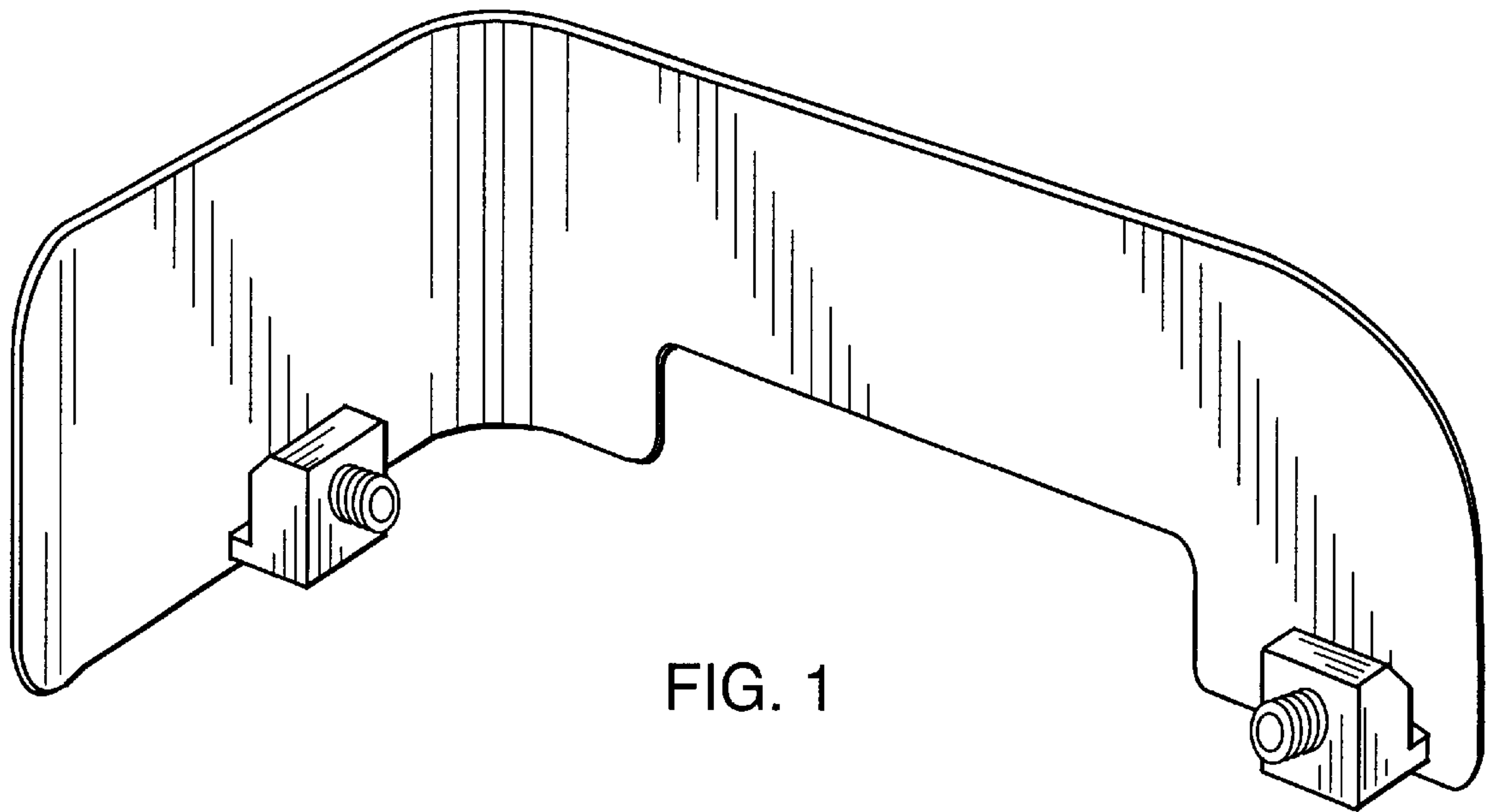

FIG. 1

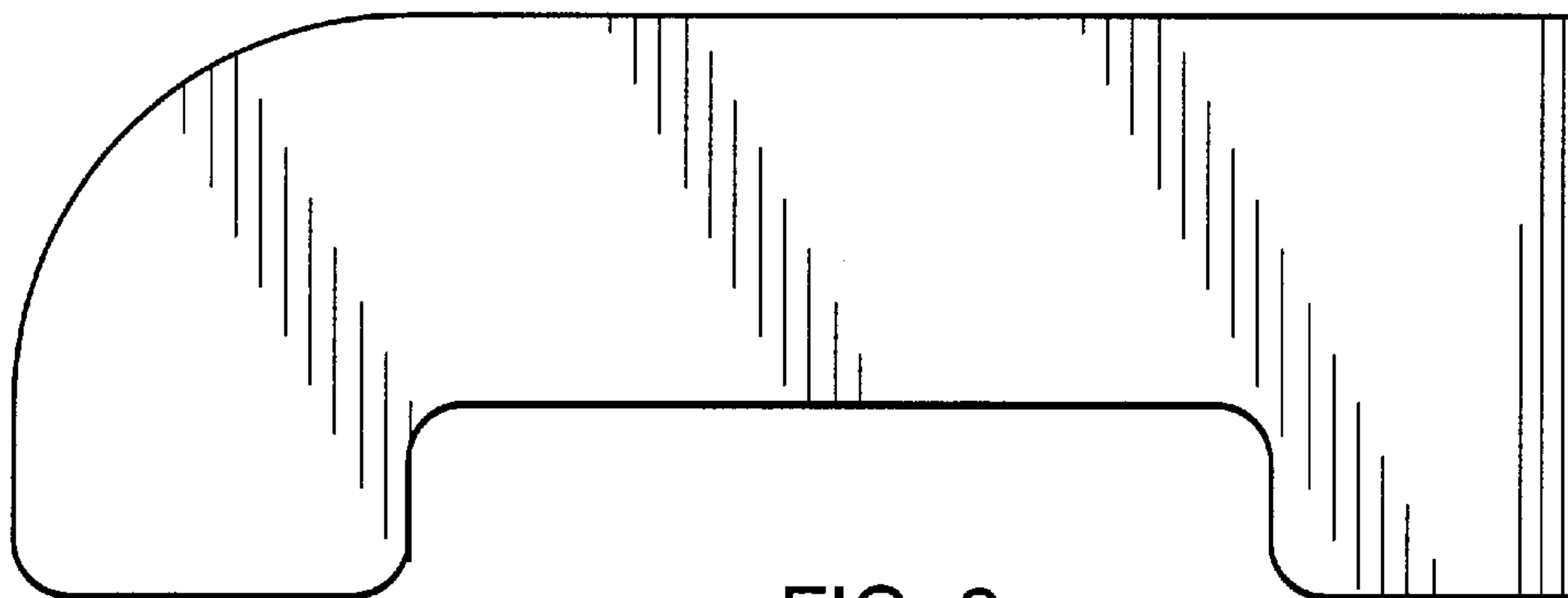

FIG. 2

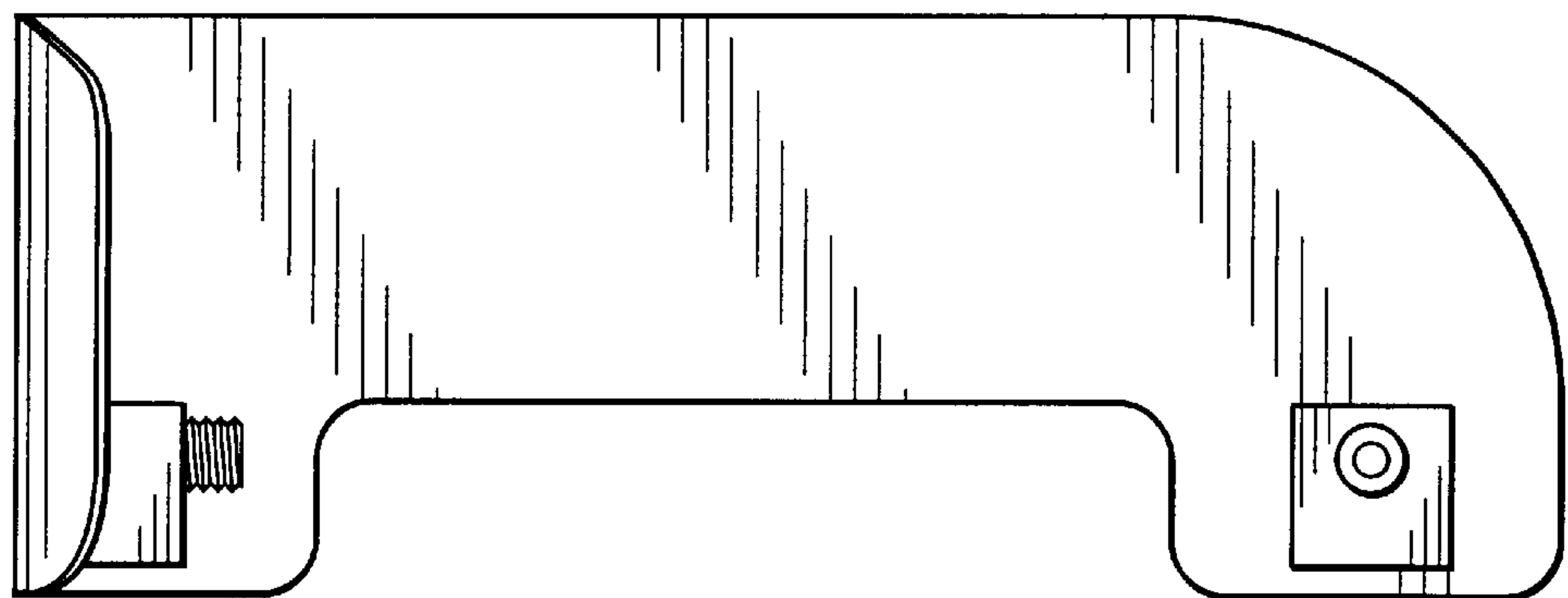

FIG. 3

FIG. 4

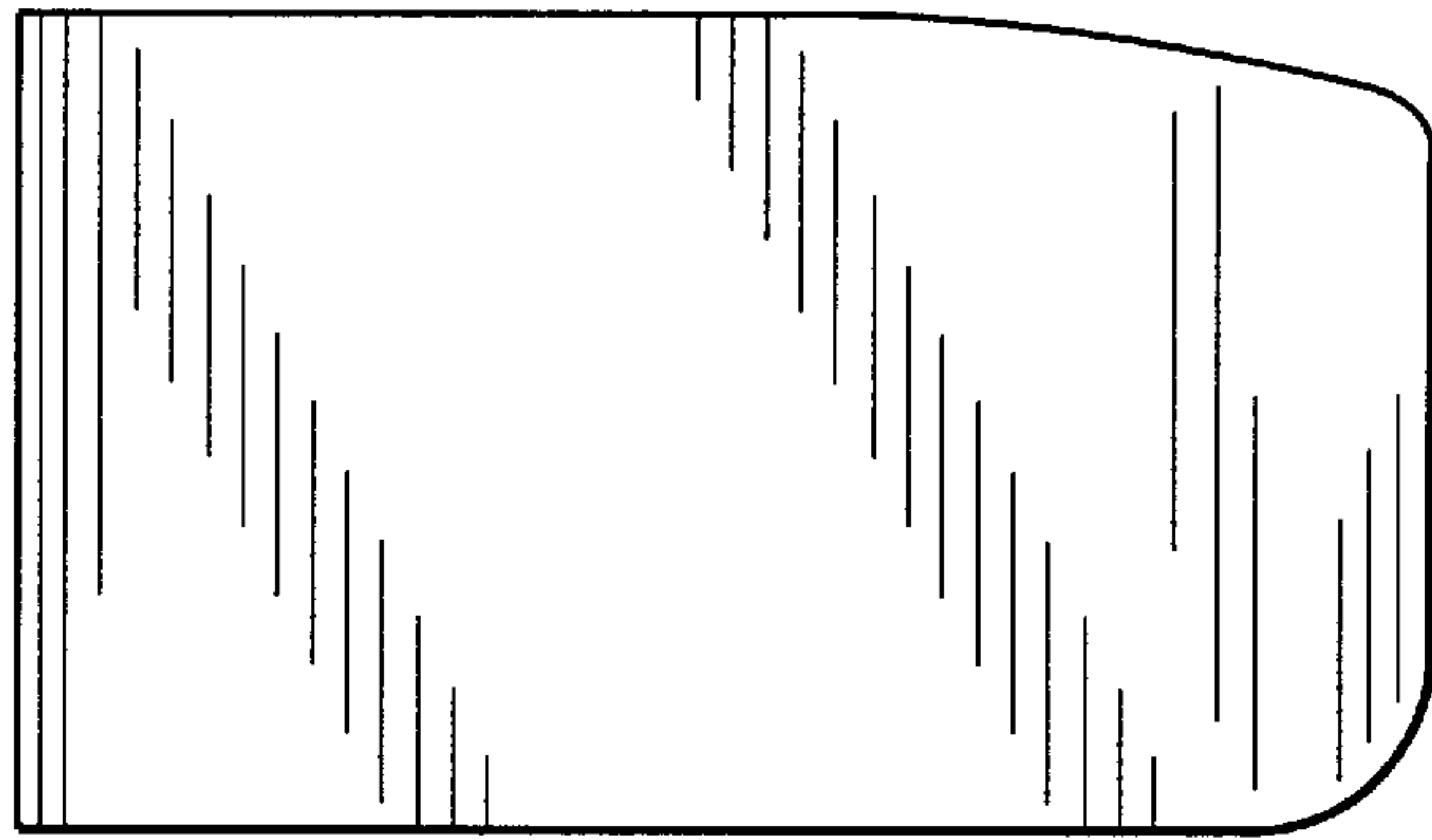

FIG. 5

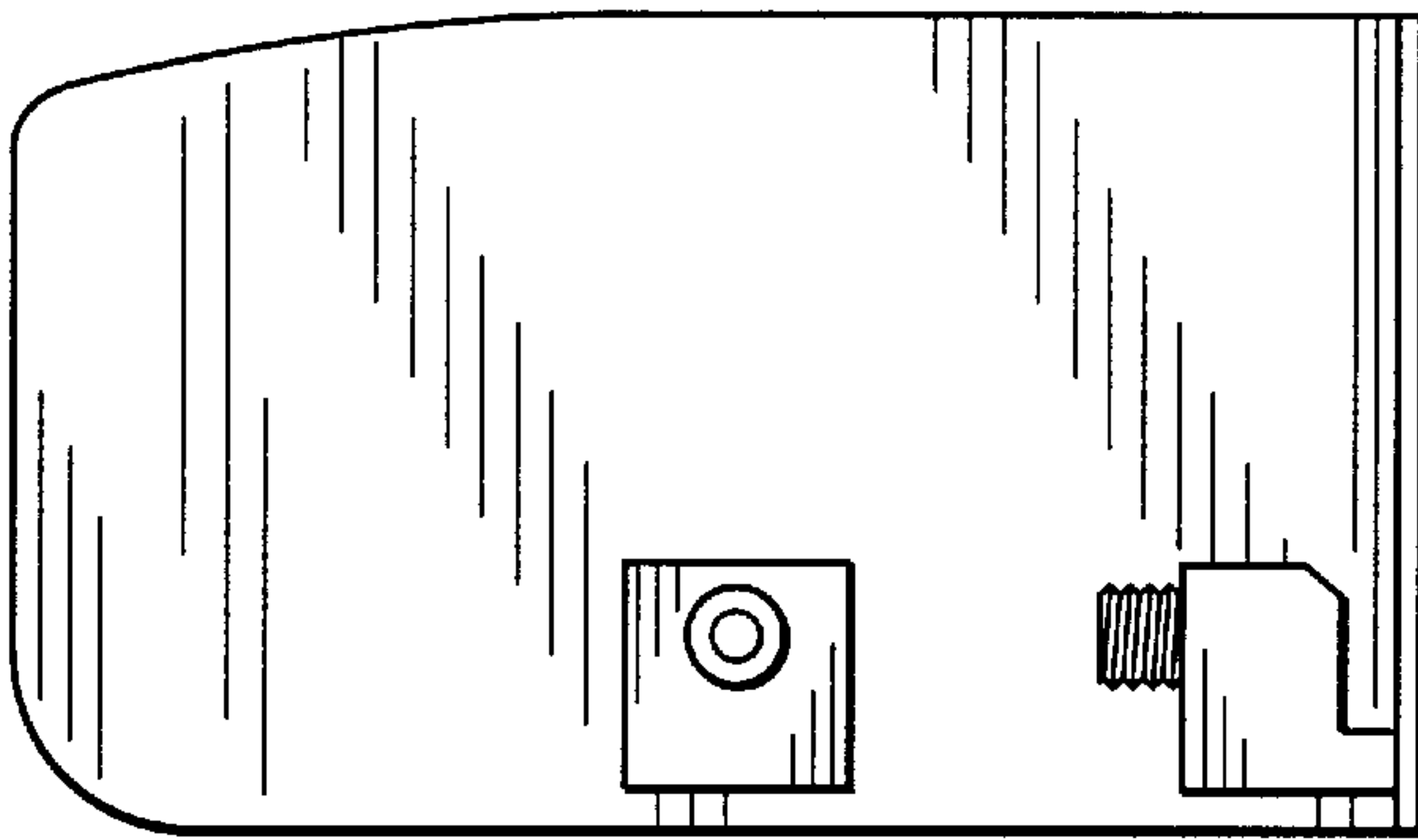

FIG. 6

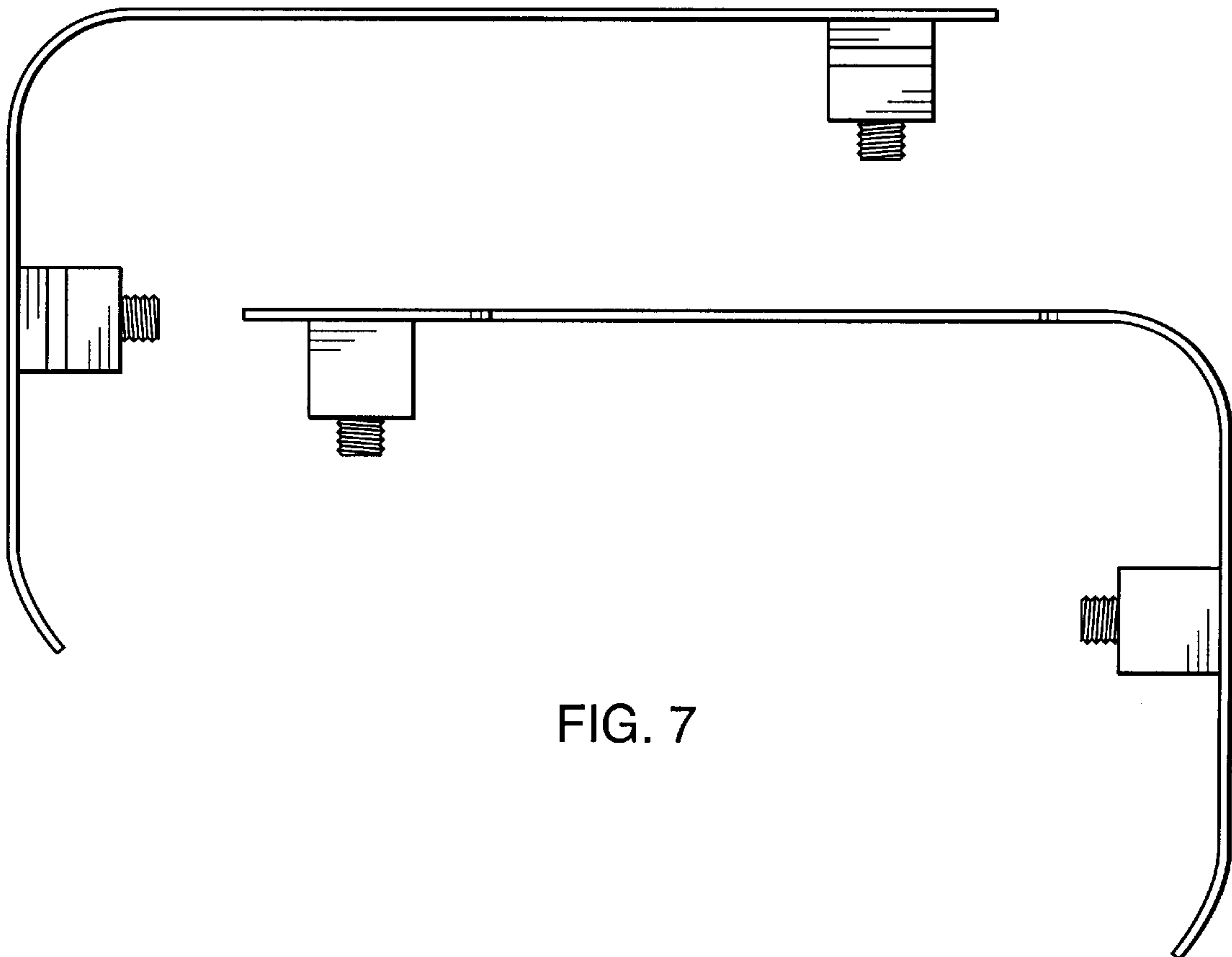

FIG. 7

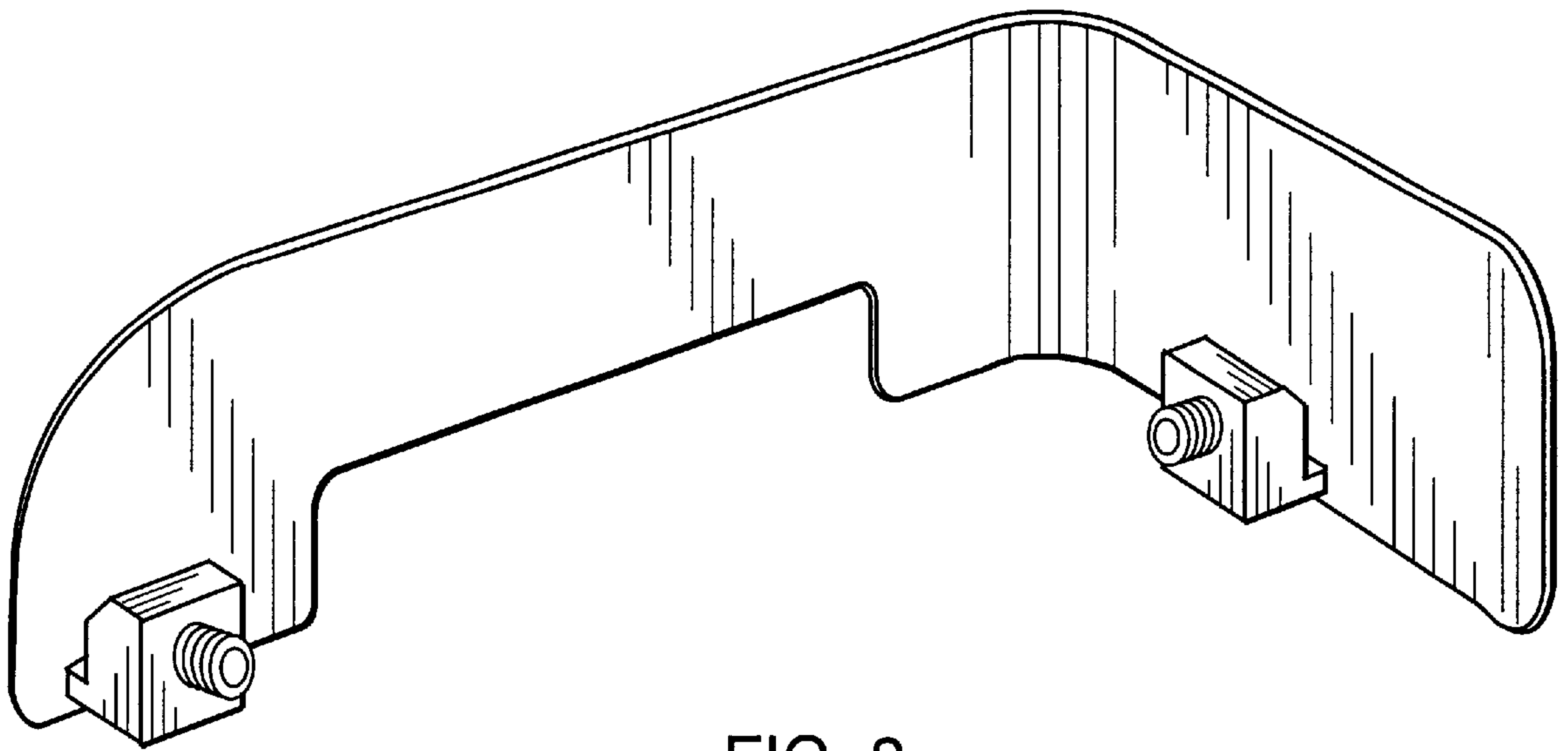

FIG. 8

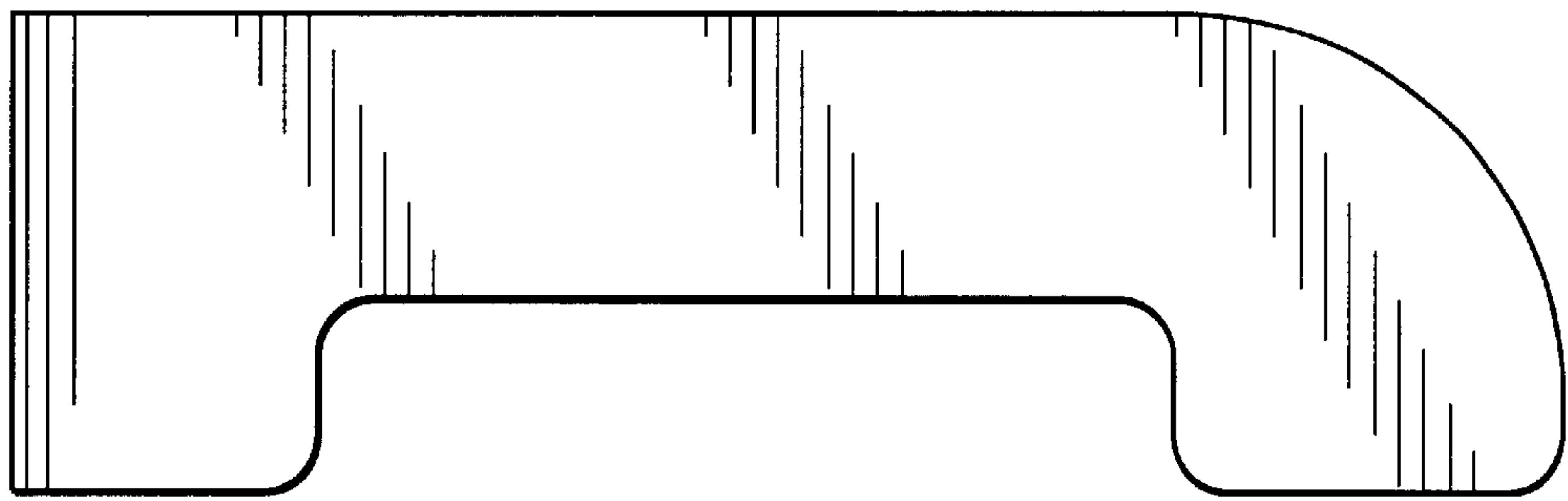

FIG. 9

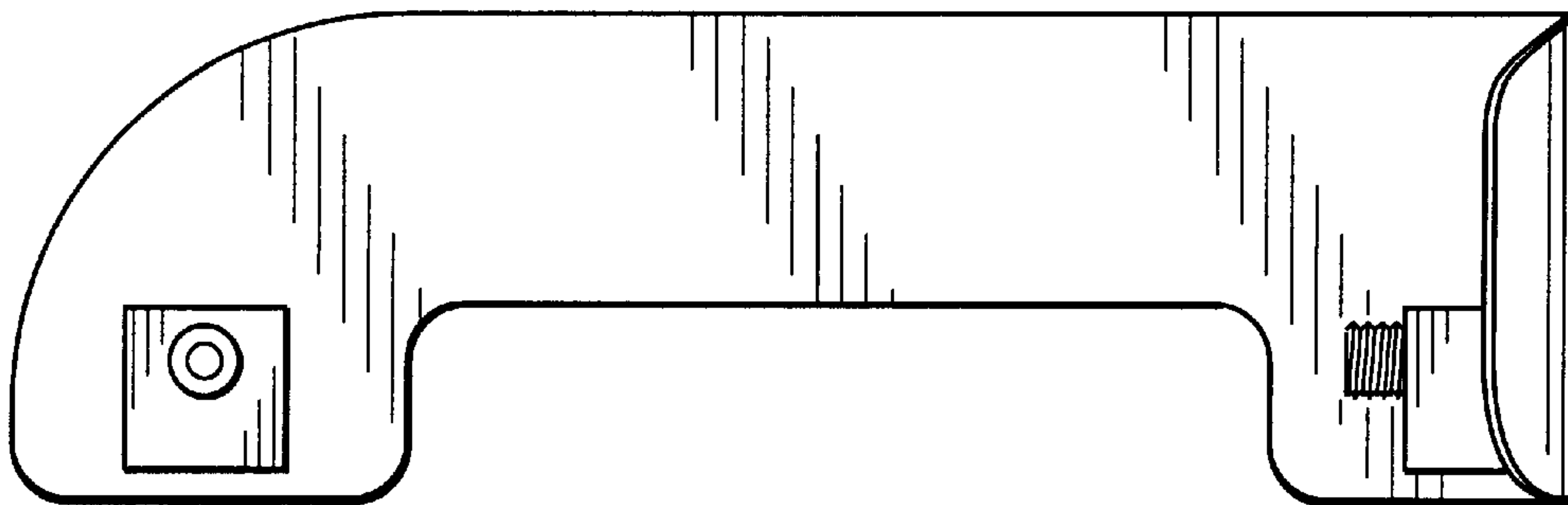

FIG. 10

FIG. 11

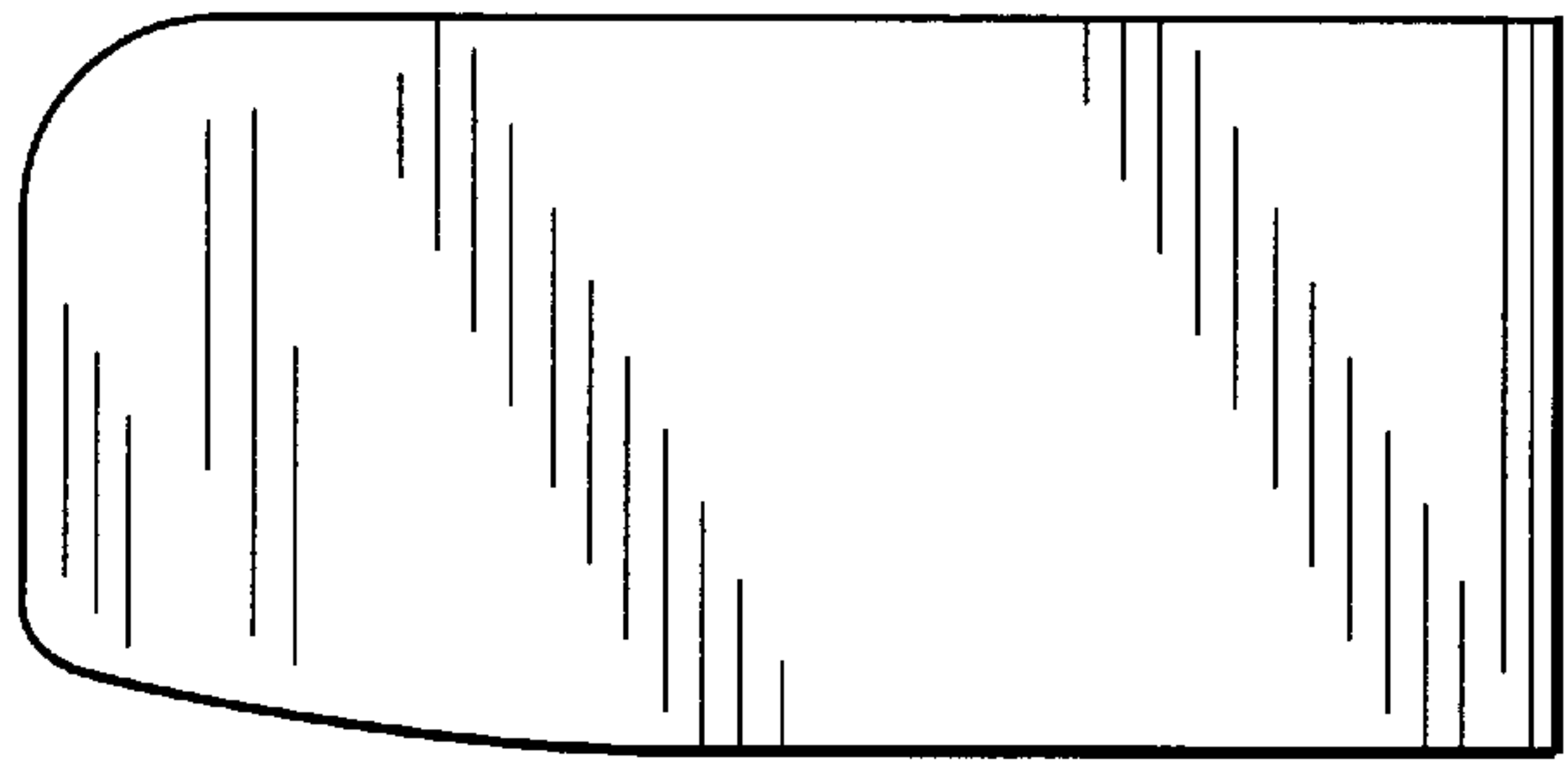

FIG. 12

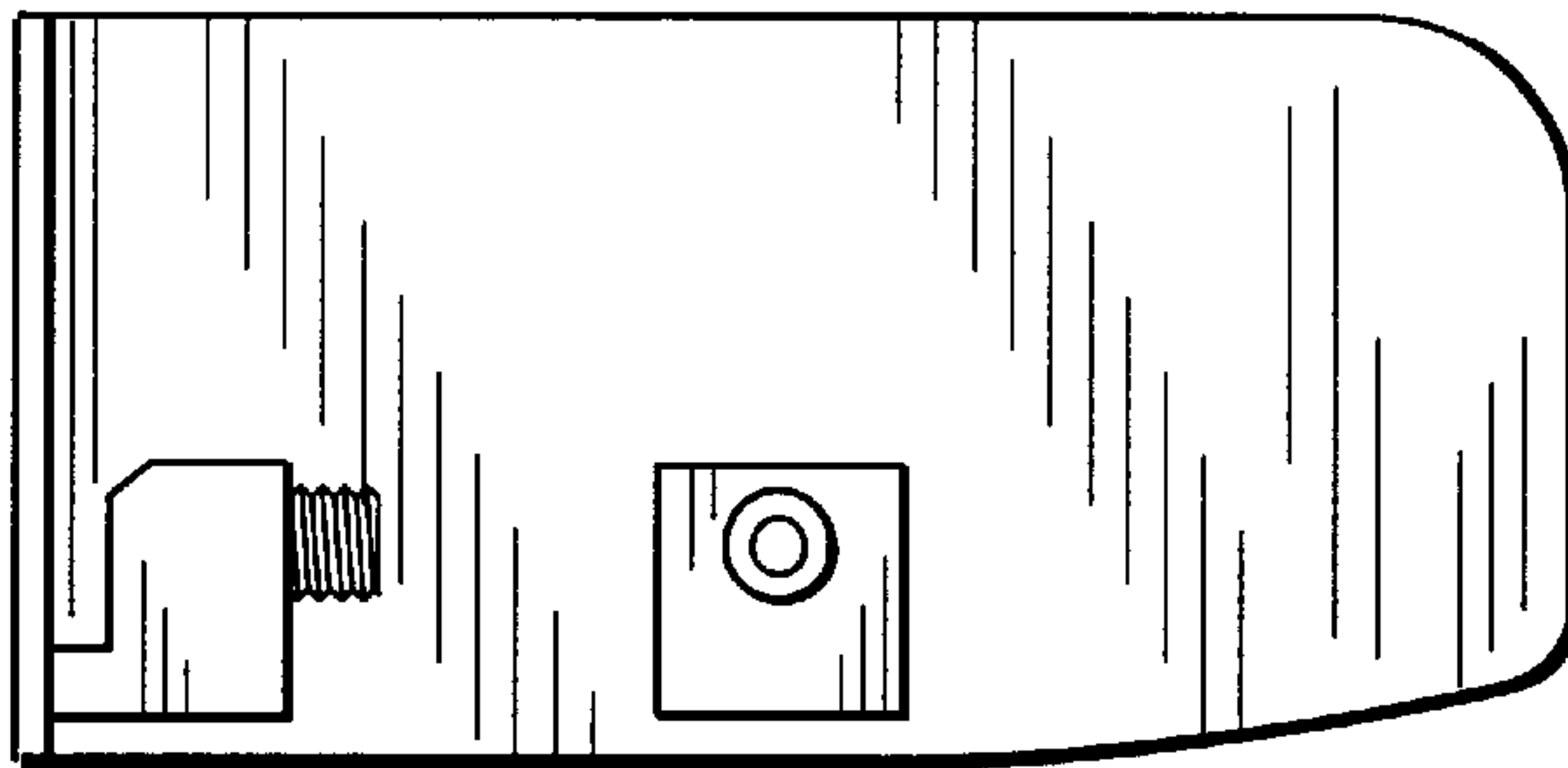

FIG. 13

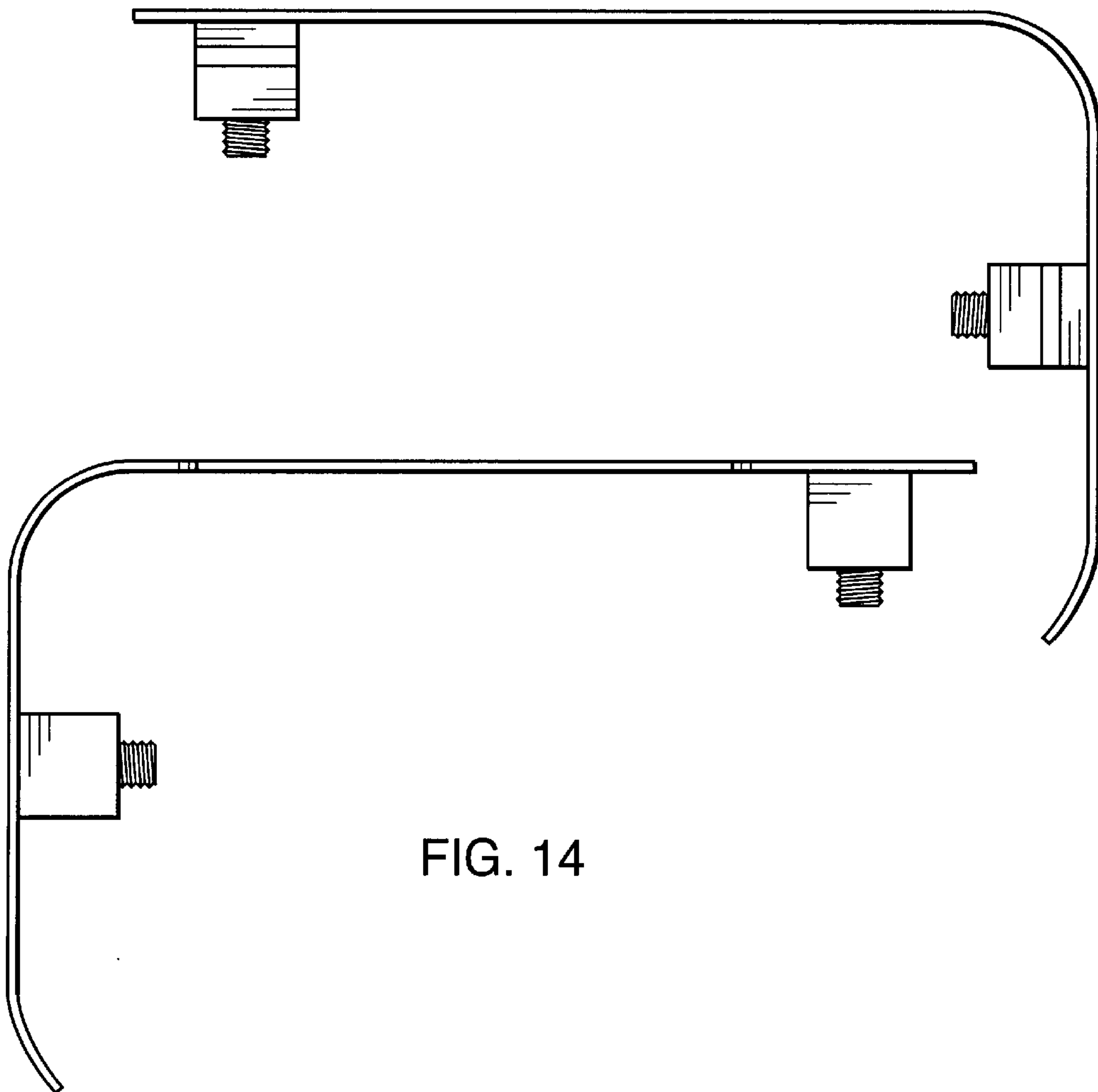

FIG. 14