



US00D479577S

(12) **United States Design Patent**
Engelbrektsson

(10) **Patent No.: US D479,577 S**

(45) **Date of Patent: ** Sep. 9, 2003**

(54) **PRESSURE REGULATOR**

(75) Inventor: **Anders Engelbrektsson, Herrljunga (SE)**

(73) Assignee: **Tour & Andersson AB, Ljung (SE)**

(**) Term: **14 Years**

(21) Appl. No.: **29/164,133**

(22) Filed: **Jul. 17, 2002**

(30) **Foreign Application Priority Data**

Jan. 28, 2002 (DK) DA 2002 00069

(51) **LOC (7) Cl. 23-01**

(52) **U.S. Cl. D23/235**

(58) **Field of Search** D23/233, 235,
D23/244-6; 251/61.1, 61.2, 118, 305, 324,
332, 335.3, 349, 352, 366; 137/116.3, 505,
505.42, 527, 527.6

(56) **References Cited**

U.S. PATENT DOCUMENTS

1,733,432	A	*	10/1929	Slinger	D23/235	X
2,841,359	A	*	7/1958	Berck	137/219	X
D213,104	S	*	1/1969	Towsend	D23/233	
4,284,098	A	*	8/1981	Kruschik	137/219	
4,421,298	A	*	12/1983	Kujawski	251/368	
D299,521	S	*	1/1989	Kiyota et al.	D23/245	
D301,915	S	*	6/1989	Fisher et al.	D23/233	
4,991,619	A	*	2/1991	Porta	137/240	
D332,822	S	*	1/1993	Reid et al.	D23/233	
D335,918	S	*	5/1993	Glansk	D23/245	
5,271,601	A	*	12/1993	Bonzer et al.	251/61.1	
D348,096	S	*	6/1994	Greenwood et al.	D23/245	
5,383,646	A	*	1/1995	Weingarten	251/61.1	

5,385,334	A	*	1/1995	Greenwood et al.	251/335.3	
5,664,760	A	*	9/1997	Army, Jr. et al.	251/118	
D403,049	S	*	12/1998	Ohtani et al.	D23/233	
5,909,747	A	*	6/1999	Schieber	137/492	
D421,092	S	*	2/2000	Martin	D23/233	
6,095,484	A	*	8/2000	Frenkel	251/61.1	
D439,311	S	*	3/2001	Martin	D23/233	

* cited by examiner

Primary Examiner—Nelson C. Holtje

(74) *Attorney, Agent, or Firm*—Davis & Bujold, P.L.L.C.

(57) **CLAIM**

The ornamental design for a pressure regulator.

DESCRIPTION

FIG. 1 is a perspective view from below showing my new design;
 FIG. 2 is a side elevational view from one side of the pressure regulator shown in FIG. 1;
 FIG. 3 is a side elevational view from the other side of the pressure regulator shown in FIG. 1;
 FIG. 4 is a perspective view from above of the pressure regulator shown in FIG. 1;
 FIG. 5 is a top plan view of the pressure regulator shown in FIG. 1;
 FIG. 6 is a bottom plan view of the pressure regulator shown in FIG. 1;
 FIG. 7 is a perspective view from below from another angle of the pressure regulator shown in FIG. 1;
 FIG. 8 is a perspective view from above from another angle of the pressure regulator shown in FIG. 1; and,
 FIG. 9 is an exploded perspective view of the design of FIGS. 1-8.

1 Claim, 5 Drawing Sheets

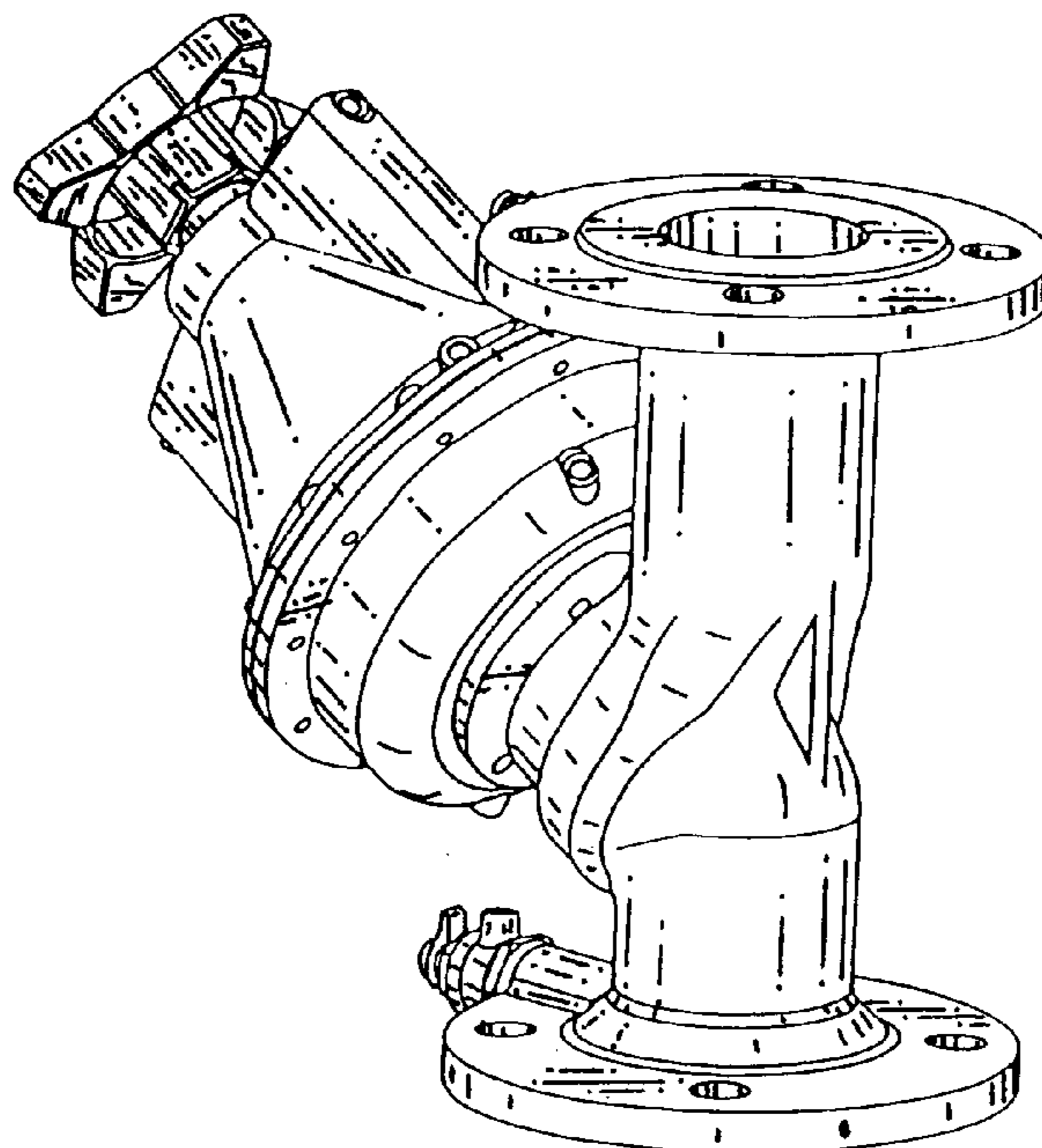

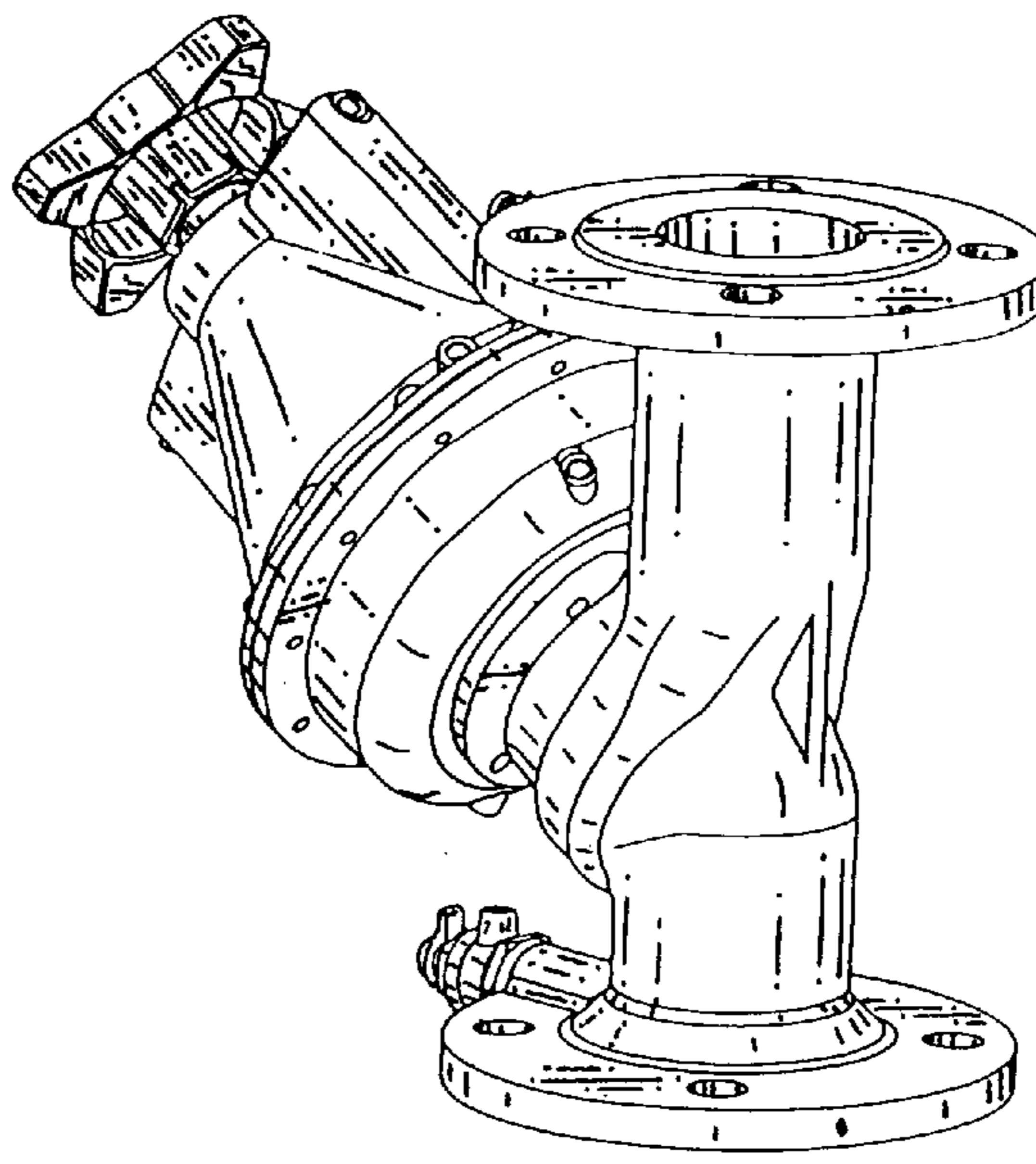

Fig. 1

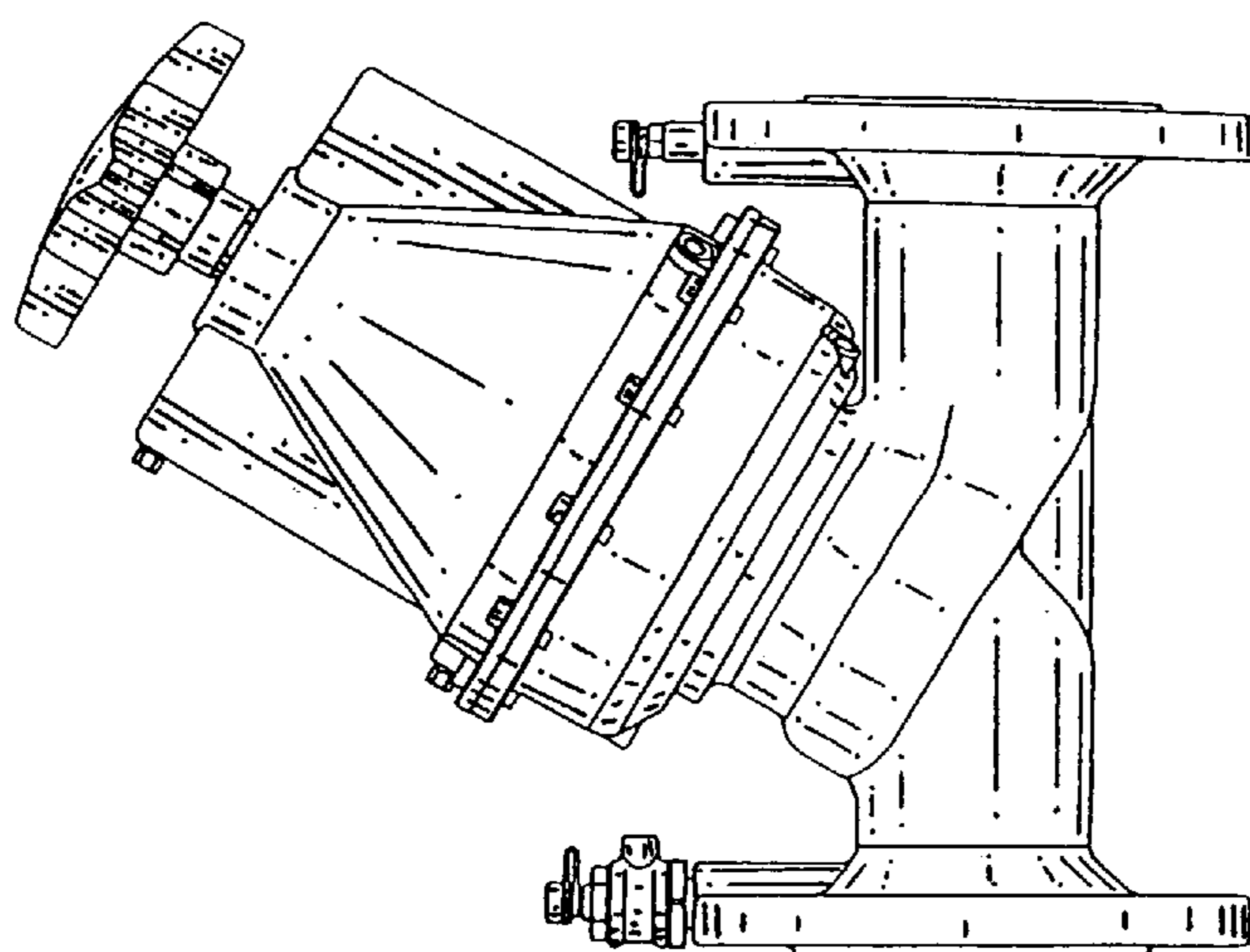

Fig. 2

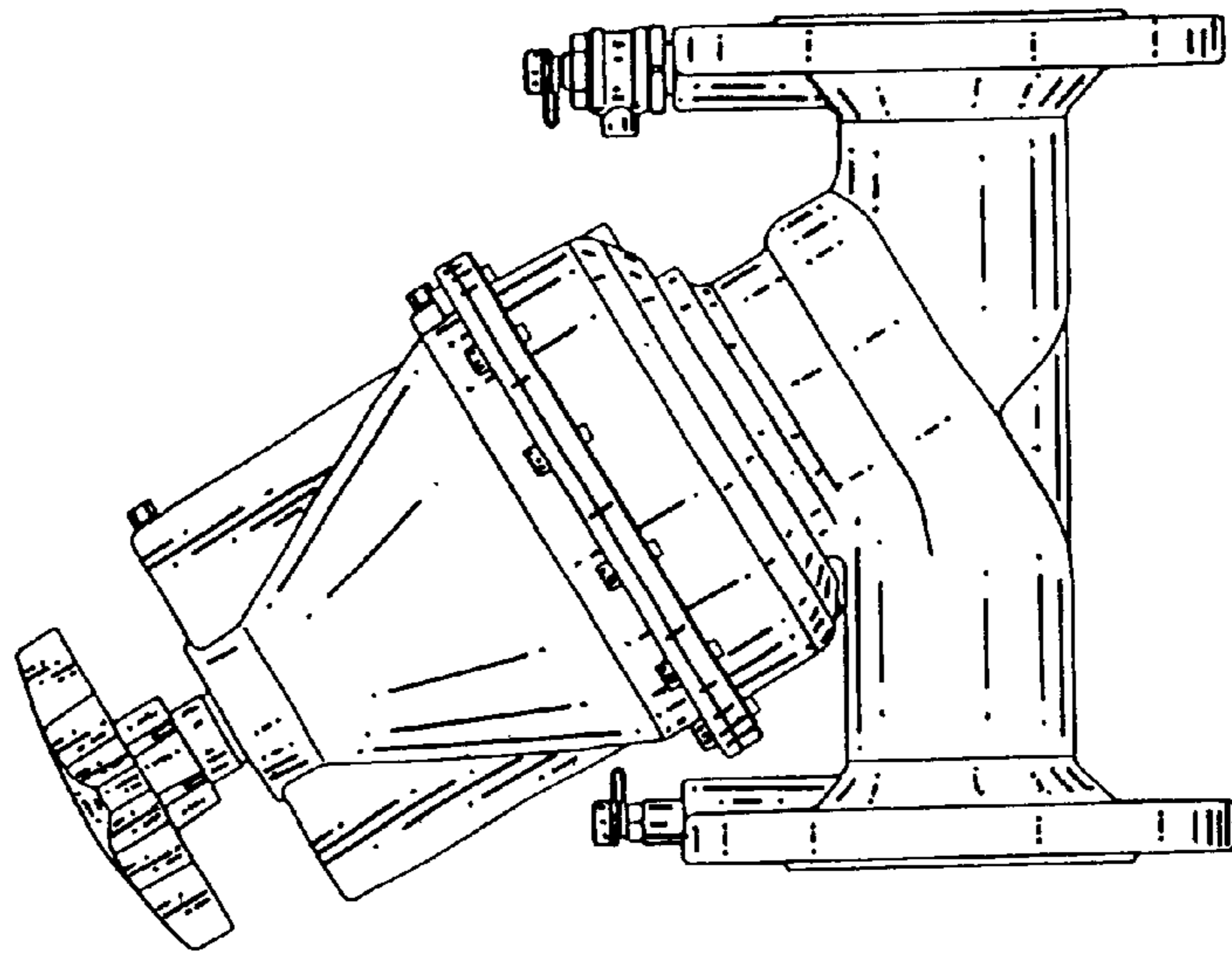

Fig. 3

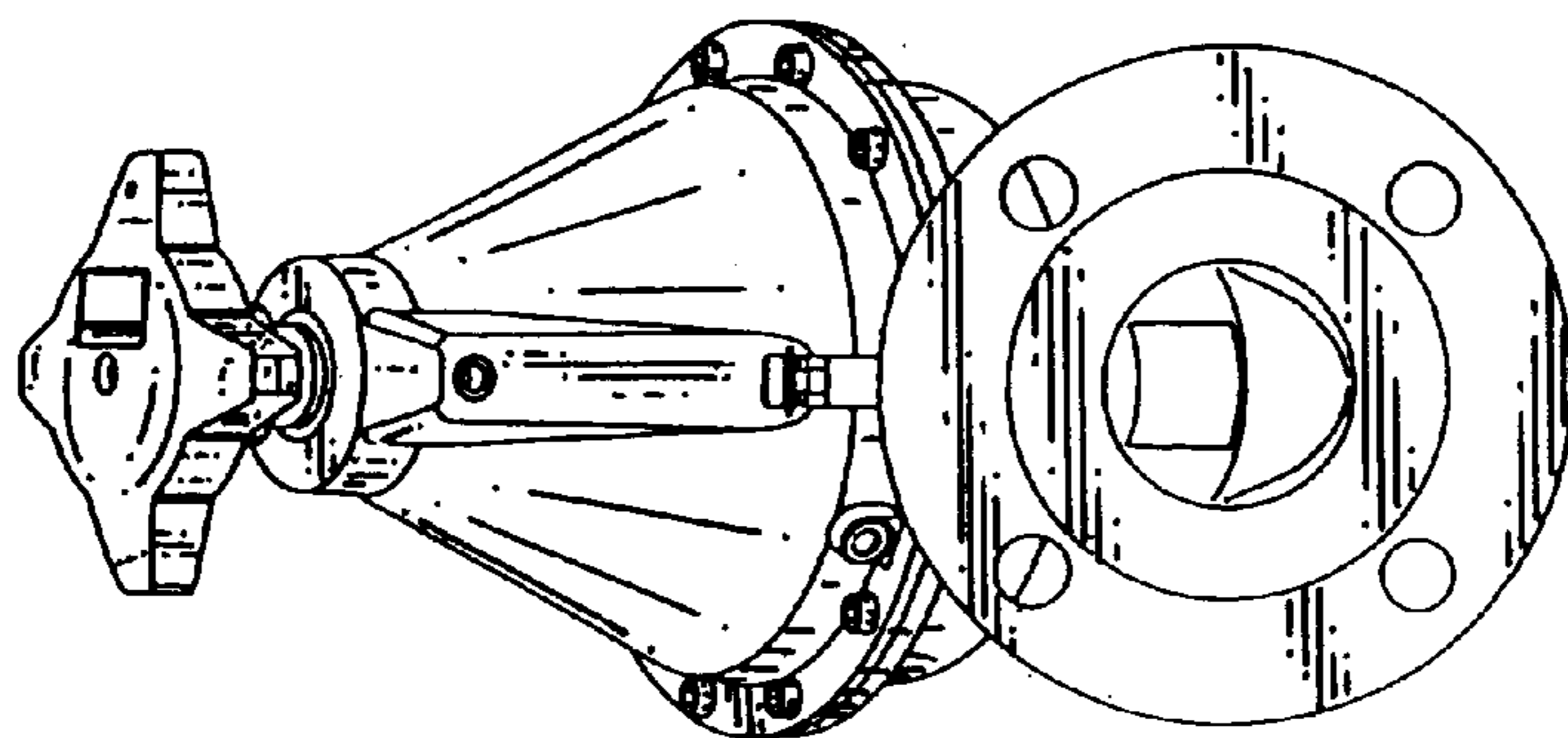

Fig. 4

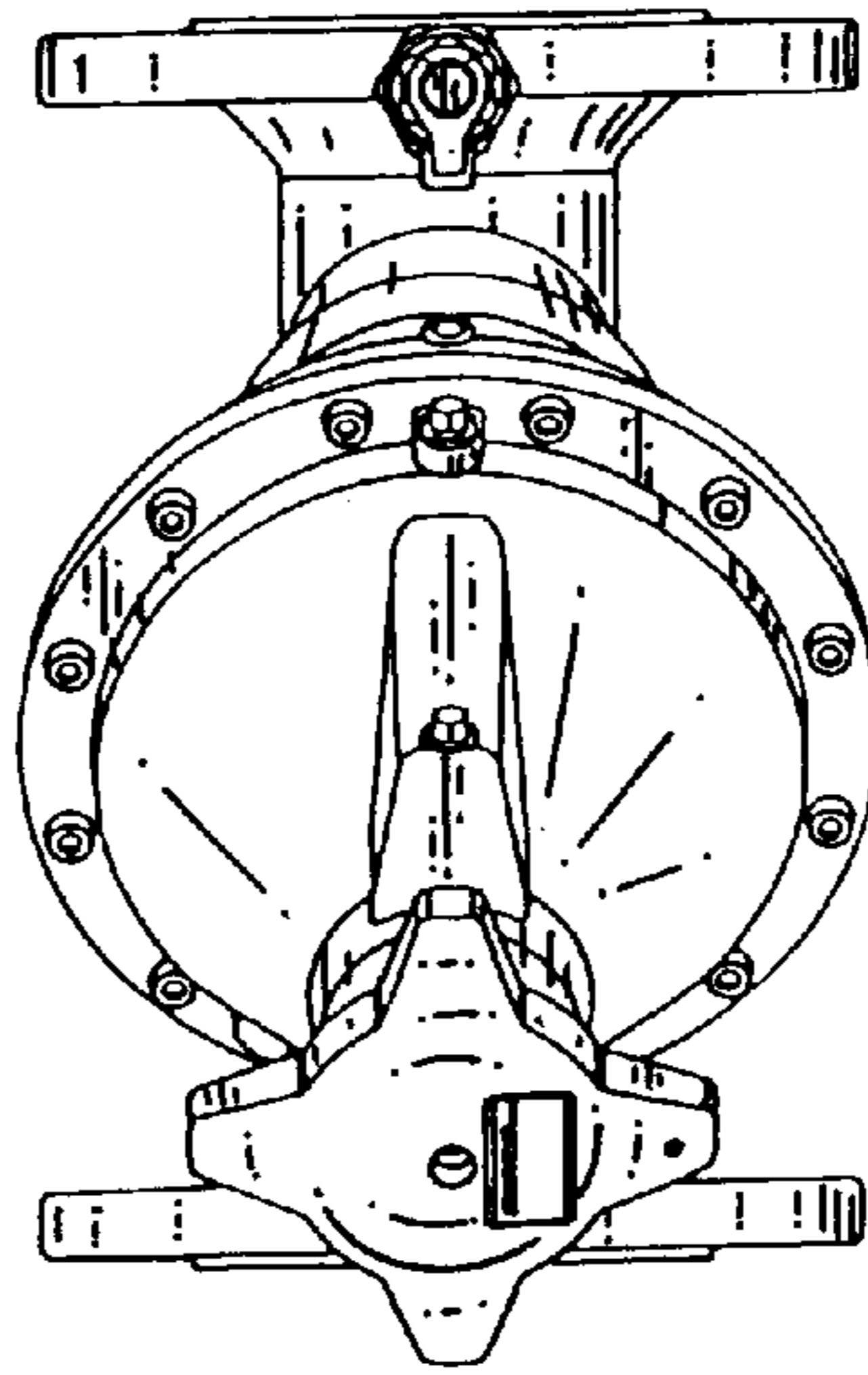

Fig. 5

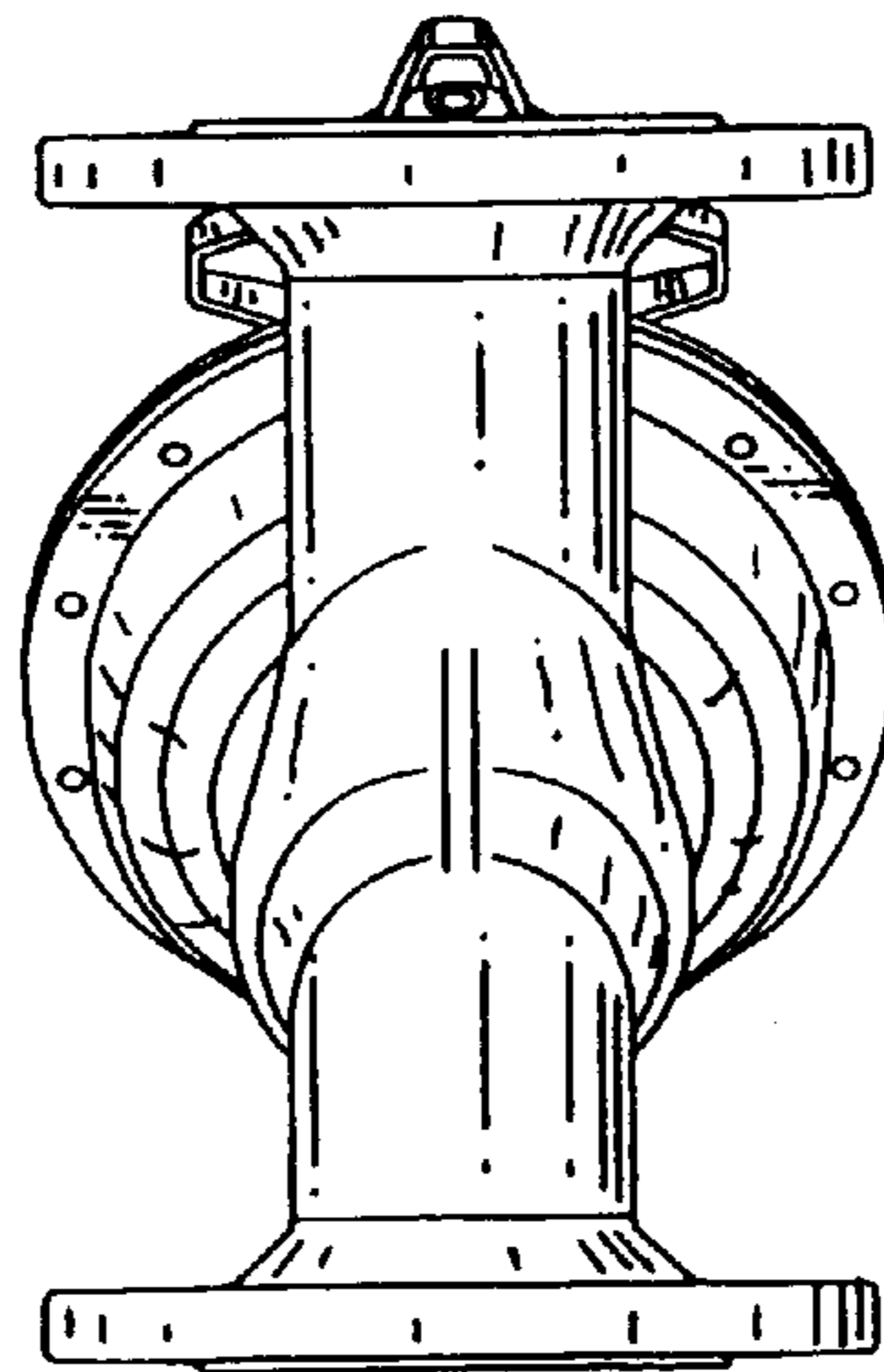

Fig. 6

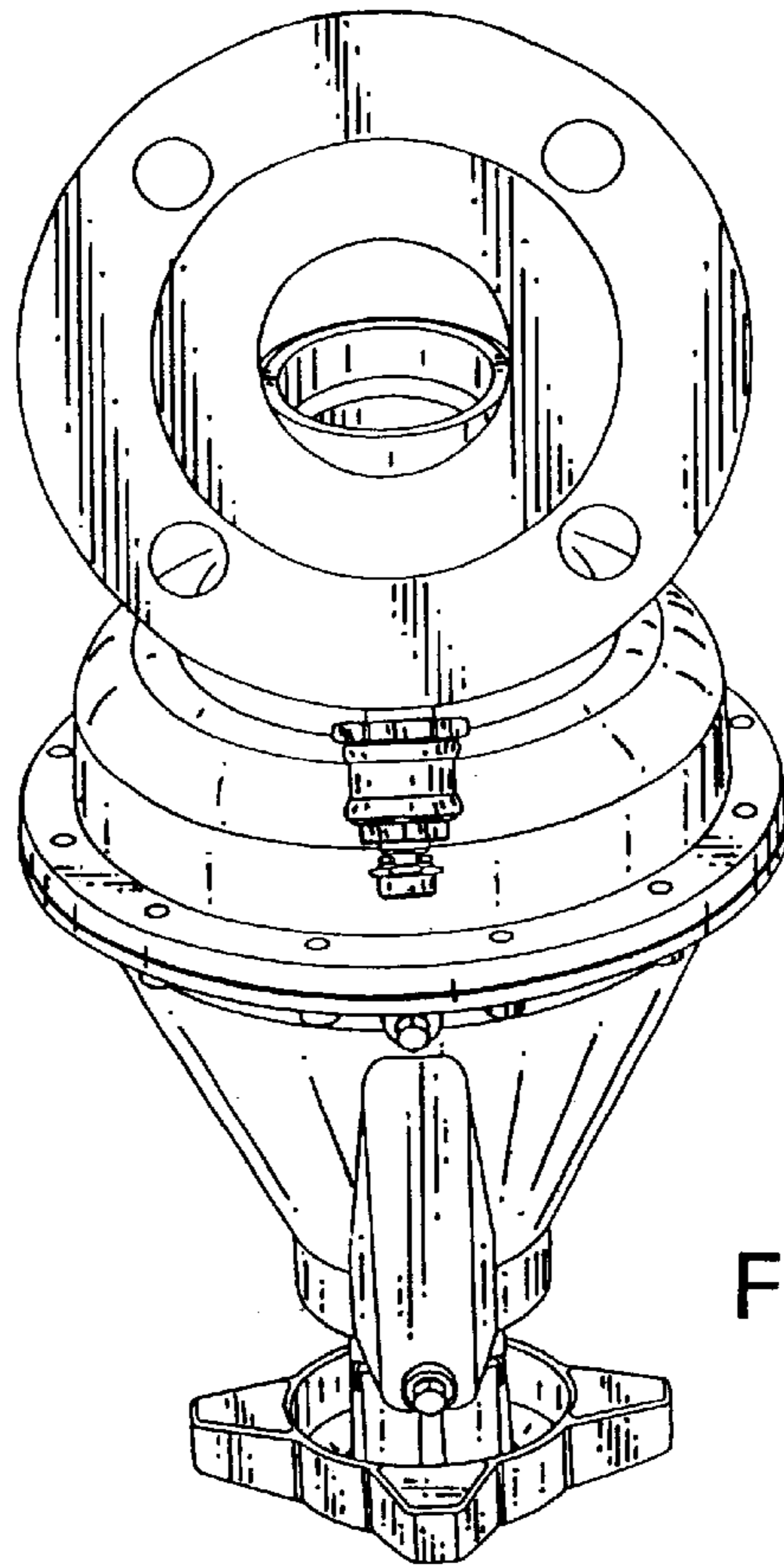

Fig. 7

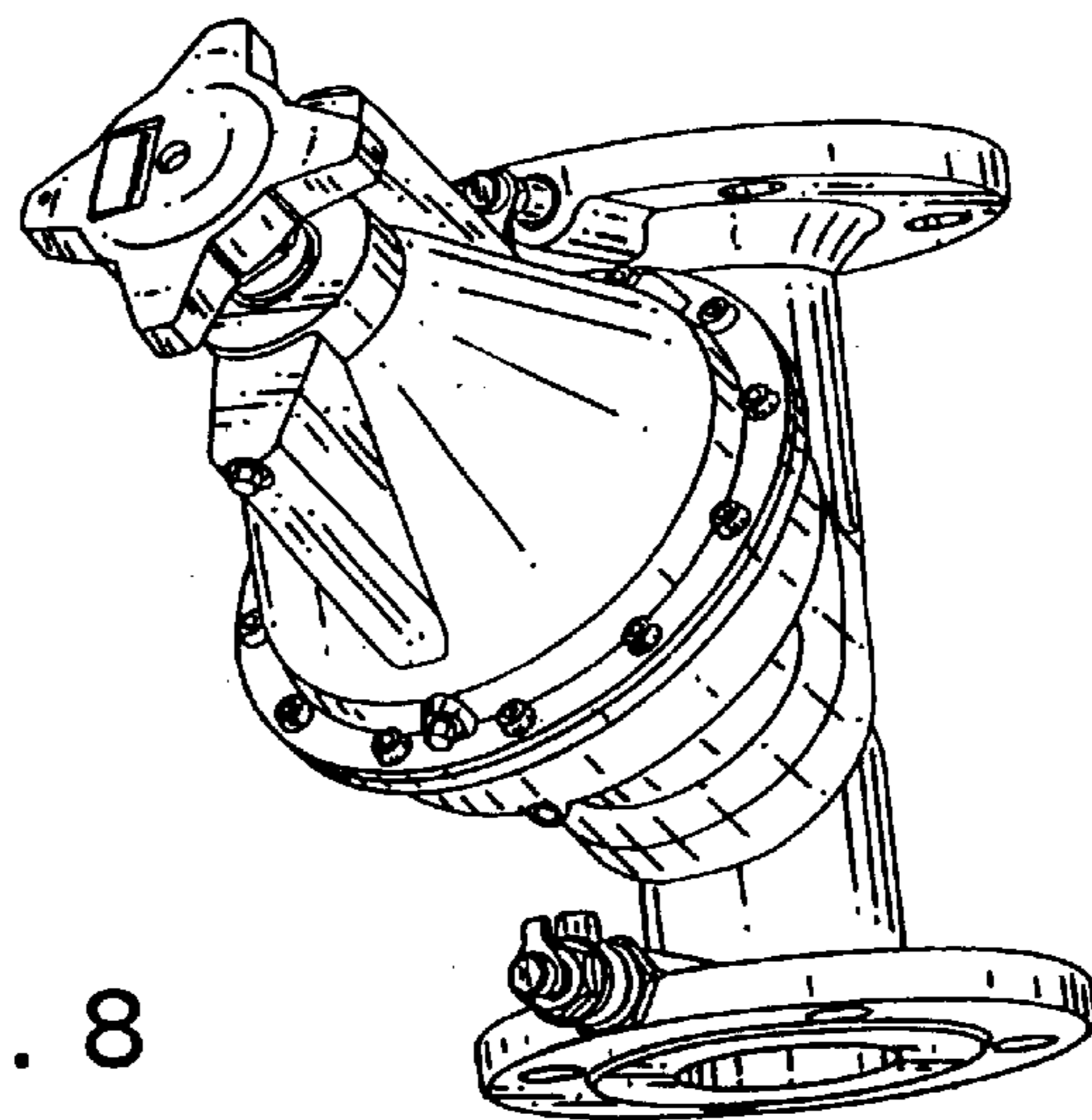

Fig. 8

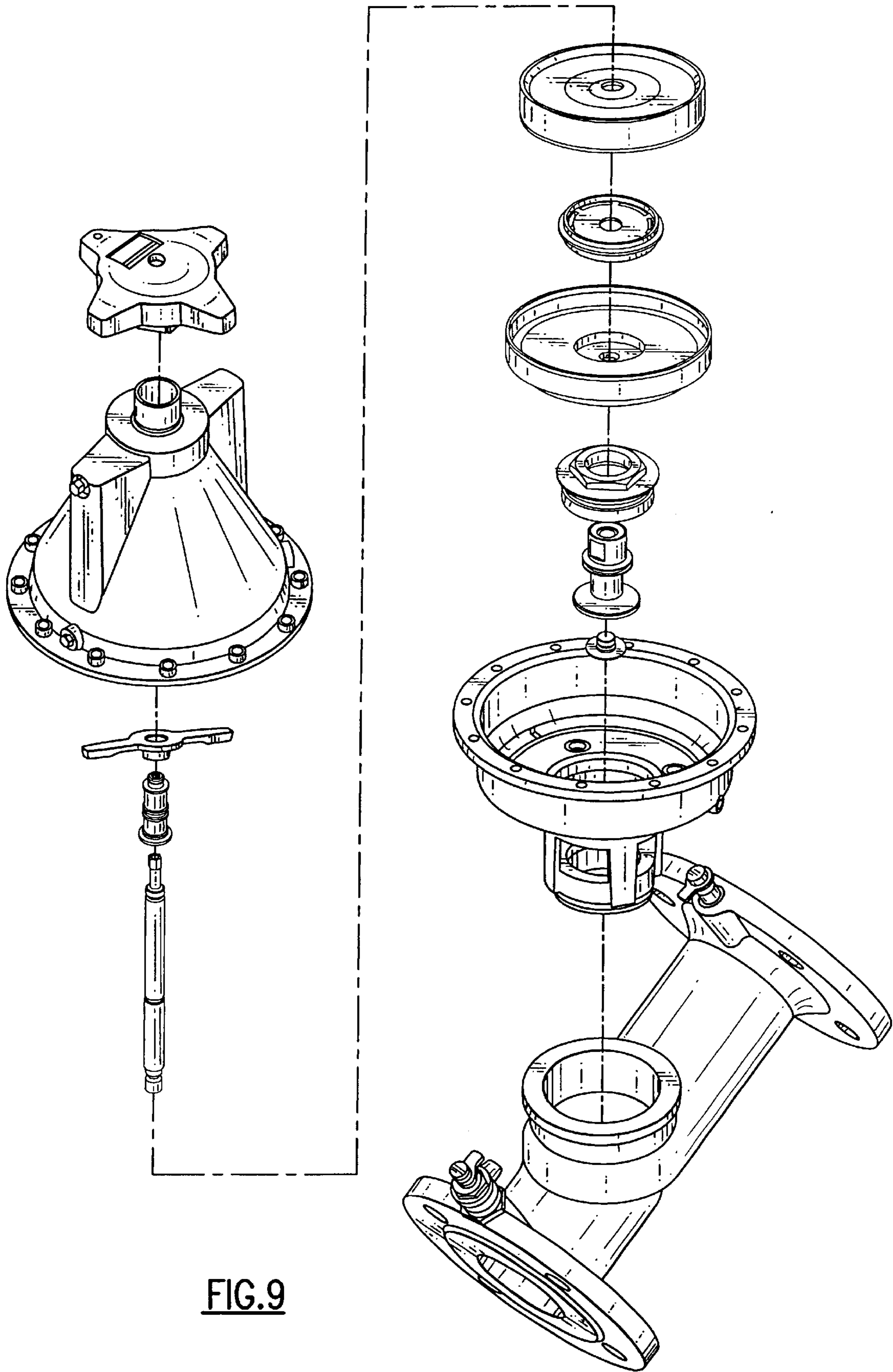

FIG. 9