



US00D479501S

(12) **United States Design Patent**
Nelson

(10) **Patent No.:** **US D479,501 S**

(45) **Date of Patent:** **** Sep. 9, 2003**

(54) **HIGH-SPEED AIRCRAFT**

(75) Inventor: **Chester P. Nelson**, Kirkland, WA (US)

(73) Assignee: **The Boeing Company**, Seattle, WA (US)

(**) Term: **14 Years**

(21) Appl. No.: **29/168,026**

(22) Filed: **Sep. 24, 2002**

Related U.S. Application Data

(63) Continuation of application No. 29/152,202, filed on Oct. 30, 2001, which is a continuation of application No. 29/138,990, filed on Mar. 22, 2001, now abandoned.

(51) **LOC (7) Cl.** **12-12**

(52) **U.S. Cl.** **D12/319**

(58) **Field of Search** D12/319-345;
244/45 R, 45 A, 13, 15, 91, 198, 211, 218

(56) **References Cited**

U.S. PATENT DOCUMENTS

2,604,276	A	7/1952	Huben
2,856,165	A	8/1958	Axelson
2,941,752	A	6/1960	Gluhareff

(List continued on next page.)

FOREIGN PATENT DOCUMENTS

EP	000547266	A1	6/1993
WO	WO 82/00048		1/1982

OTHER PUBLICATIONS

International Search Report for International Application No. PCT/US02/01567, Dec. 12, 2002 (5 pages).

U.S. patent application Ser. No. 09/671,870, Clark, filed Sep. 27, 2000.

(List continued on next page.)

Primary Examiner—Marcus A. Jackson
(74) *Attorney, Agent, or Firm*—Perkins Coie LLP

(57) **CLAIM**

The ornamental design for a high-speed aircraft, as shown and described.

DESCRIPTION

FIG. 1 is a top, left, isometric view of a first embodiment of a high-speed aircraft showing my new design.

FIG. 2 is a top plan view thereof.

FIG. 3 is a bottom plan view thereof.

FIG. 4 is left-side elevational view thereof; the right-side elevational view is a mirror image thereof.

FIG. 5 is a front elevational view thereof.

FIG. 6 is a rear elevational view thereof.

FIG. 7 is a top, left, isometric view of a second embodiment of a high-speed aircraft showing my new design.

FIG. 8 is a top plan view thereof.

FIG. 9 is a bottom plan view thereof.

FIG. 10 is left-side elevational view thereof; the right-side elevational view is a mirror image thereof.

FIG. 11 is a front elevational view thereof.

FIG. 12 is a rear elevational view thereof.

FIG. 13 is a top, left, isometric view of a third embodiment of a high-speed aircraft showing my new design.

FIG. 14 is a top plan view thereof.

FIG. 15 is a bottom plan view thereof.

FIG. 16 is left-side elevational view thereof; the right-side elevational view is a mirror image thereof.

FIG. 17 is a front elevational view thereof.

FIG. 18 is a rear elevational view thereof.

FIG. 19 is a top, left, isometric view of a fourth embodiment of a high-speed aircraft showing my new design.

FIG. 20 is a top plan view thereof.

FIG. 21 is a bottom plan view thereof.

FIG. 22 is left-side elevational view thereof; the right-side elevational view is a mirror image thereof.

FIG. 23 is a front elevational view thereof; and,

FIG. 24 is a rear elevational view thereof.

Elements identified by broken lines in the accompanying drawings form no part of the claimed invention.

1 Claim, 8 Drawing Sheets

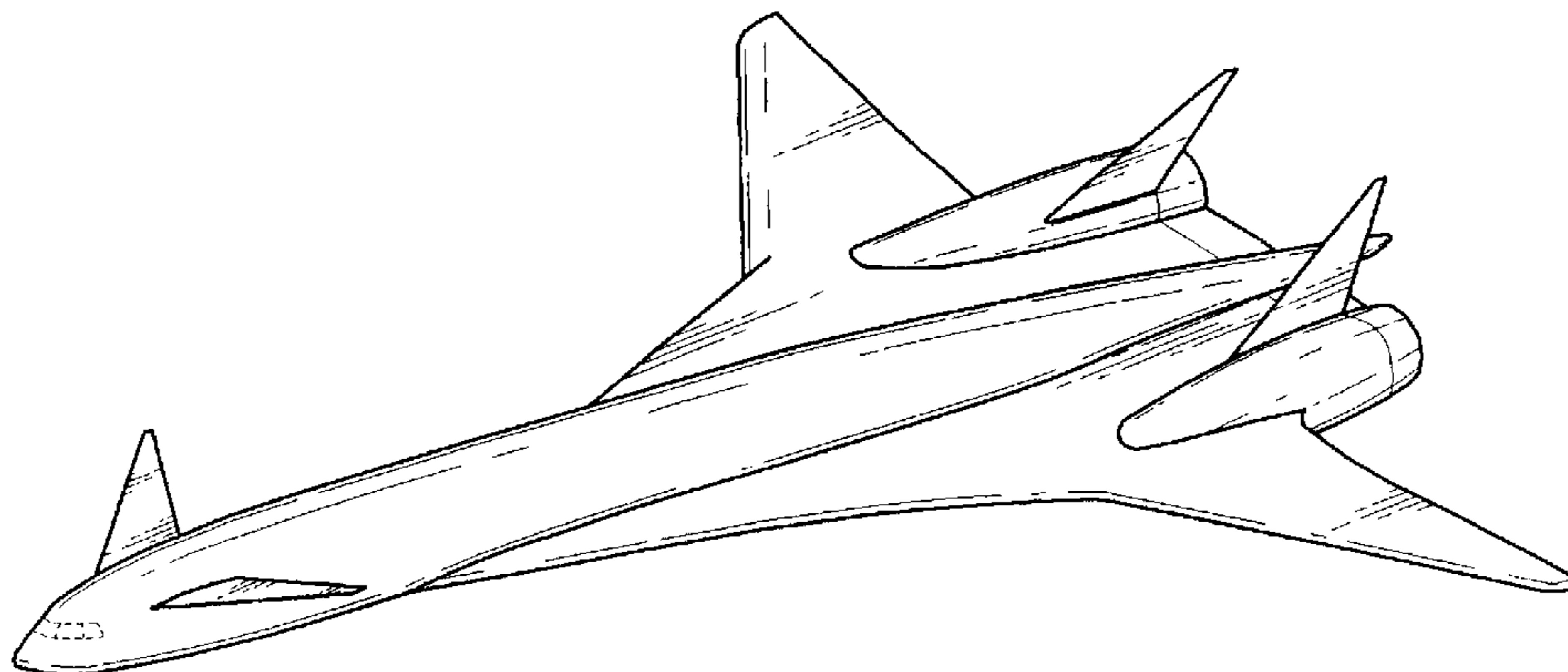

U.S. PATENT DOCUMENTS

3,109,610	A	11/1963	Quenzler et al.	
3,237,891	A	3/1966	Wotton	
3,493,198	A	2/1970	Roed	
3,592,415	A	7/1971	Walley	
3,680,816	A	8/1972	Mello	
3,738,595	A	6/1973	Bouchnik	
3,900,178	A	8/1975	Tupolev et al.	
3,940,097	A	2/1976	Wilson et al.	
3,948,469	A	4/1976	Brown	
3,954,231	A	5/1976	Fraser	
4,008,867	A	2/1977	Kaniut	
4,026,500	A	5/1977	Grow	
4,116,405	A	9/1978	Bacchi et al.	
4,378,097	A	3/1983	Ferguson et al.	
4,478,377	A	10/1984	Fletcher et al.	
4,478,378	A	10/1984	Capuani	
4,579,300	A	4/1986	Carr	
4,767,083	A	8/1988	Koenig et al.	
4,899,958	A	2/1990	Horikawa	
4,969,614	A	11/1990	Capuani	
4,979,699	A	12/1990	Tindell	
D314,366	S	2/1991	Waland et al.	
D317,003	S	5/1991	Tribe et al.	
5,167,383	A	12/1992	Nozaki	
5,170,964	A	12/1992	Enderle et al.	
5,209,428	A	5/1993	Bevilaqua et al.	
5,216,879	A	6/1993	Zysmaan	
5,299,760	A	4/1994	Finch et al.	
5,322,242	A	6/1994	Tracy	
5,496,001	A	3/1996	Skow	
5,529,263	A	6/1996	Rudolph	
5,542,625	A	8/1996	Burhans, Jr. et al.	
RE35,387	E	12/1996	Strom	
D377,326	S	1/1997	Grossman et al.	
D381,938	S	8/1997	Grossman et al.	
D381,952	S	8/1997	Carter, Jr.	
D382,851	S	8/1997	Knutson et al.	
D386,143	S	11/1997	Astaire	
5,749,542	A	5/1998	Hamstra et al.	
D399,816	S	10/1998	Peacock	
5,842,666	A	12/1998	Gerhardt et al.	
5,897,076	A	4/1999	Tracy	
5,897,078	A	4/1999	Burnham et al.	
5,906,334	A	5/1999	Chamay et al.	
5,961,068	A	10/1999	Wainfan et al.	
D417,184	S	11/1999	Hartmann et al.	
6,079,667	A	6/2000	Gruensfelder	
6,092,360	A	7/2000	Hoag et al.	
6,138,957	A	10/2000	Nastasi et al.	
D437,284	S	2/2001	Knutson et al.	
D439,876	S	4/2001	Simonov	
D453,014	S	1/2002	Fraser	
D467,533	S	* 12/2002	Han	D12/319
D471,754	S	* 3/2003	Rouleau et al.	D12/319

OTHER PUBLICATIONS

U.S. patent application Ser. No. 09/816,985, Seidel, filed Mar. 23, 2001.

U.S. patent application Ser. No. 09/822,862, Balzer, filed Mar. 30, 2001.

Scott, William, B., "YF-23A Previews Design Features of Future Fighters," Aviation Week & Space Technology, Jul. 2, 1990.

"Photos Show Key Features of YF-23A ATF," Aviation Week & Space Technology, Jul. 9, 1990.

Dryden Flight Research Center, Feb. 1998.

Rockwell/MBB X31.

Roskam, Jan, Dr., "Airplane Design Part II: Preliminary Configuration Design and Integration of the Propulsion System," Roskam Aviation and Engineering Corporation, Ottawa, Kansas, 1985 (pp. 76-78, 81).

Poisson-Quinton, Philippe, "Slender Wings for Civil and Military Aircraft," Twentieth Israel Annual Conference on Aviation and Astronautics, Feb. 22-23, 1978 (Title Page, p. 57, Figure 5).

NASA Technical Memorandum, "Proceedings of NASA Conference on Supersonic Transport Feasibility Studies and Supporting Research," Sep. 17, 1963 (Figure 45 only).

NASA Contractor Report 165934, "Large Payload Capacity SST Concepts—Technical and Economic Feasibility," Contract NAS1-16150, Jul. 1982.

International Search Report for International Application No. PCT/US01/02368, Aug. 28, 2001.

Taylor, Michael J.H., "Jane's Pocket Book of Research and Experimental Aircraft," North American XB-70A Valkyrie, Collier Books, New York, 1976.

Liebeck, R.H. et al., AIAA 98-0438, Blended-Wing-Body Subsonic Commercial Transport, 36th Aerospace Sciences, Meeting & Exhibit, Jan. 12-15, 1998, Reno, Nevada (pp. 1 and 4).

Capone, Francis J. and Reubush, David E., "Effects of Varying Podded Nacelle-Nozzle Installations on Transonic Aeropropulsive Characteristics of a Supersonic Fighter Aircraft," NASA Technical Paper 2120, 1983 (pp. 83 and 99).

Brennan, Heather, "Spotlight on . . . Daniel Raymer," AIAA Editorial Echoes Interview with Daniel Raymer, Spring 2000 <http://www.aircraftdesign.com/sportlighton.html> [Accessed Oct. 29, 2001].

"Dan Raymer" <http://www.aircraftdesign.com/raymer.html> [Accessed Oct. 29, 2001].

Aircraft Conceptual Design Drawings & Pictures <http://www.aircraftdesign.com/acpix.html> [Accessed Oct. 30, 2001].

"Rockwell/MBB X-31 Makes Second Flight, Reaching 20,000-Ft. Altitude, Mach 0.6," Aviation Week & Space Techn., p. 117, Oct. 22, 1990.

Stinton, Darrol, "The Anatomy of the Aeroplane," Granada Publishing Limited, 1966 (p. 27, 276, 274, 162).

Angelucci, Enzo, "World Encyclopedia of Civil Aircraft, from Leonardo da Vinci to the Present," Crown Publishers, Inc., New York, 1981 (p. 364.).

"Prototypes: Comparative Design Analysis," Aviation Week & Space Technology, Sep. 17, 1990.

* cited by examiner

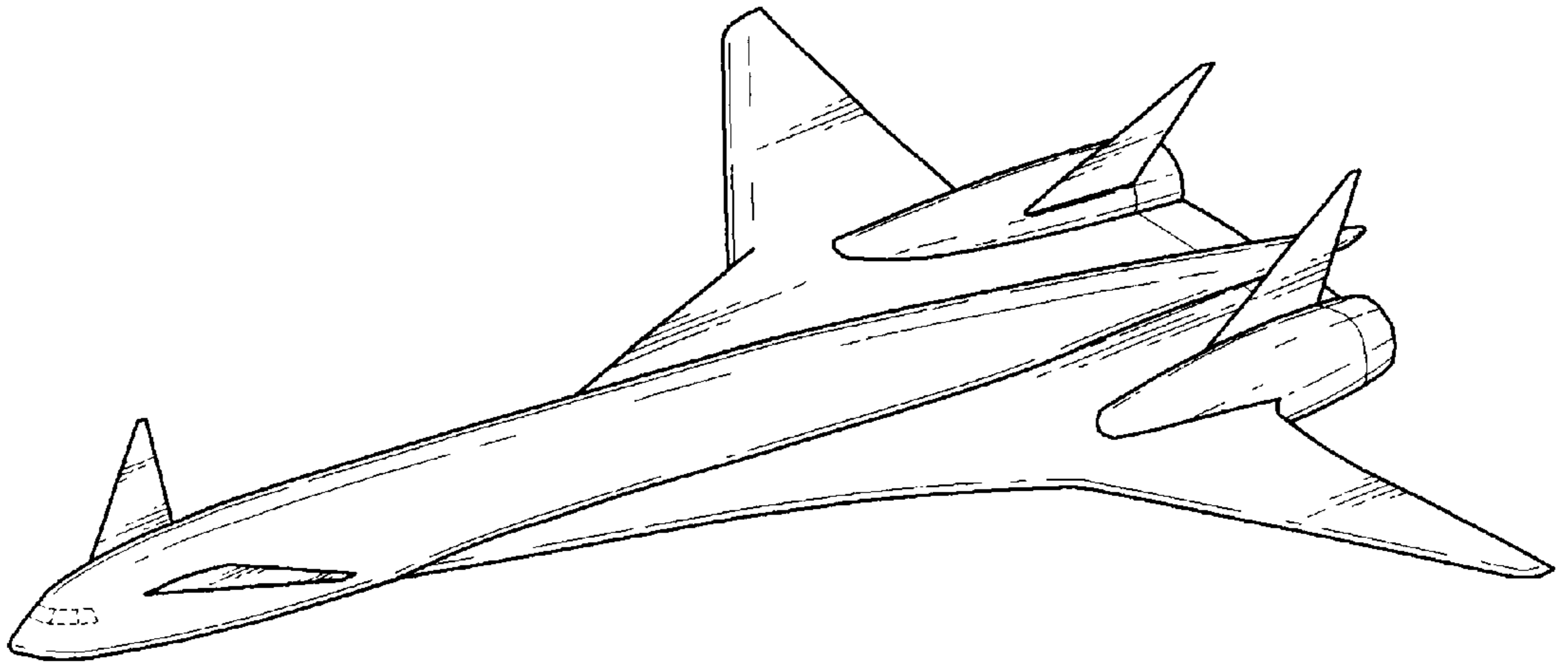

Fig. 1

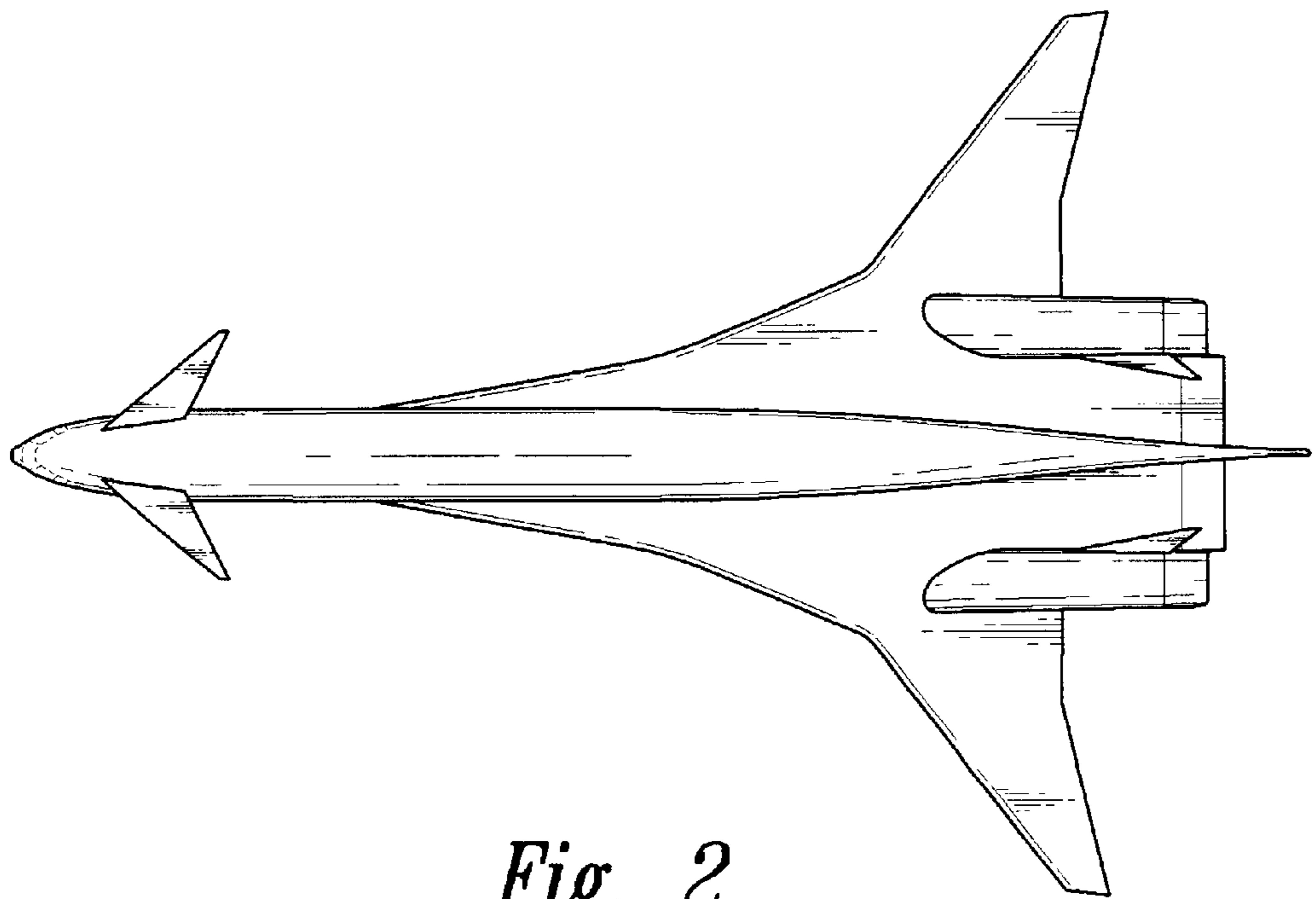

Fig. 2

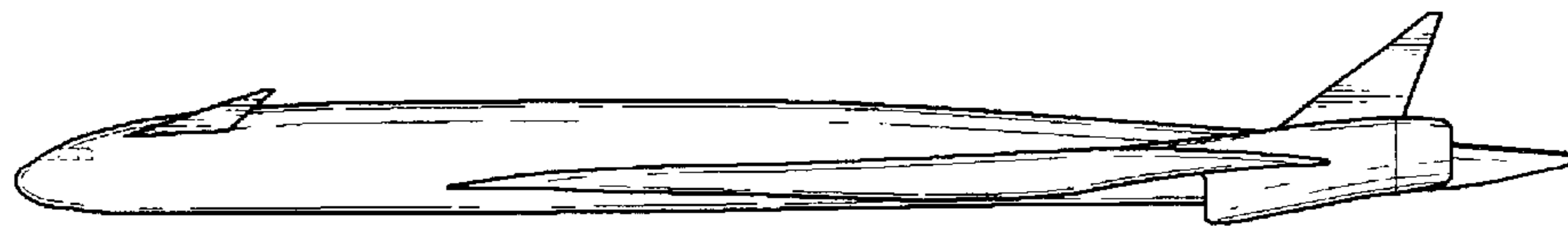
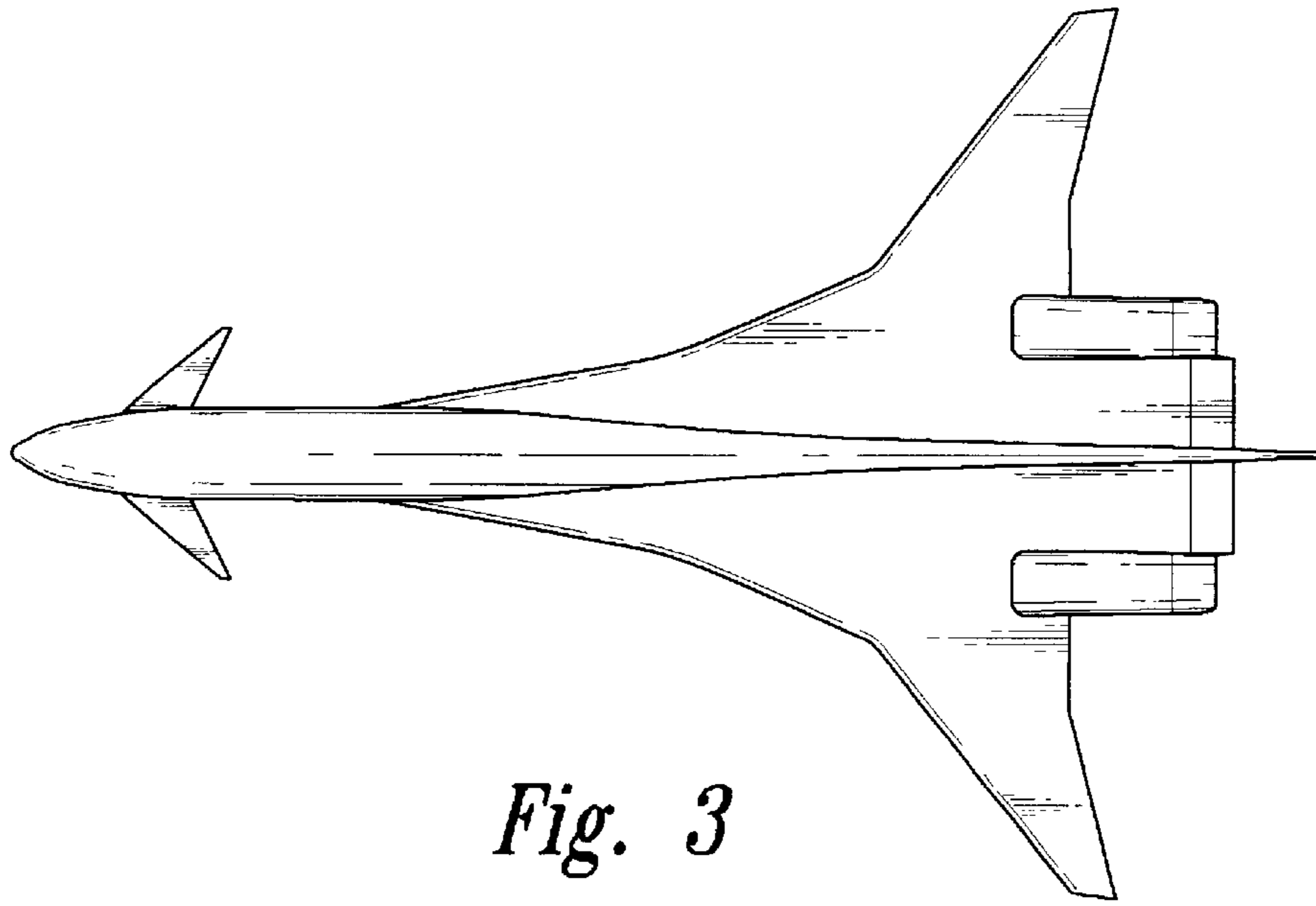

Fig. 4

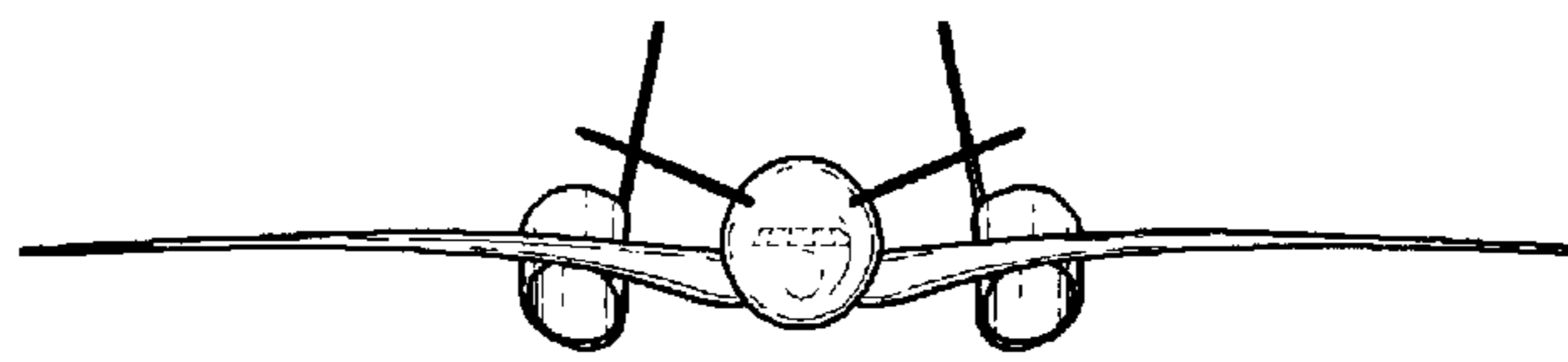

Fig. 5

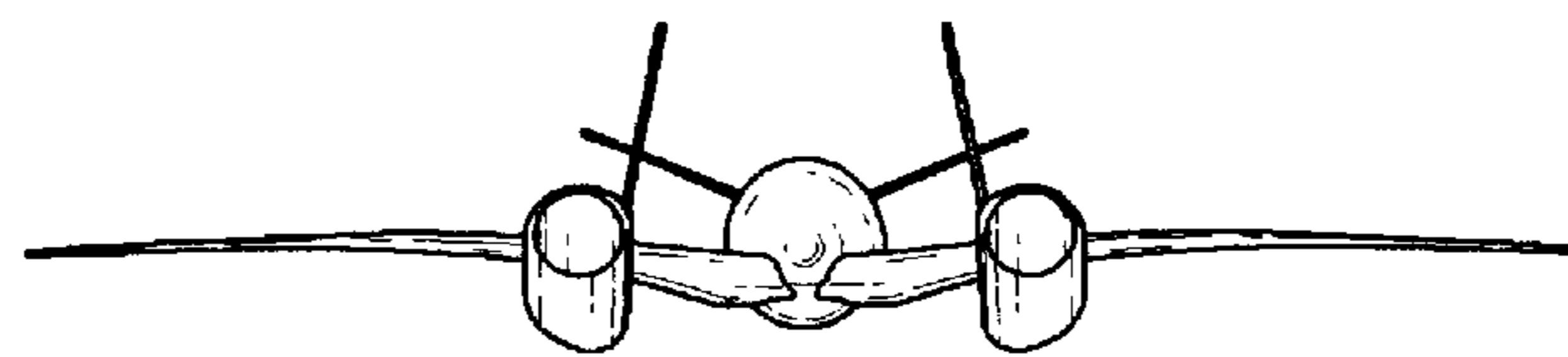

Fig. 6

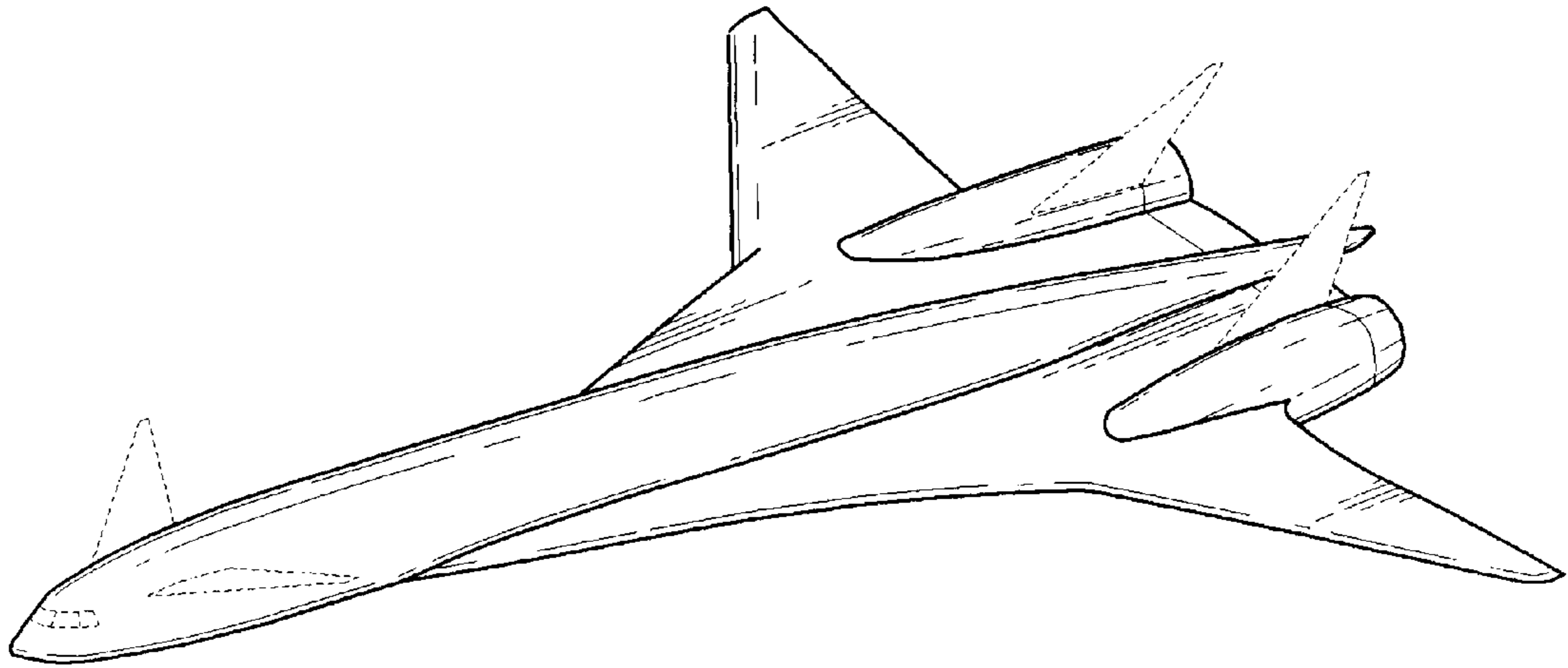

Fig. 7

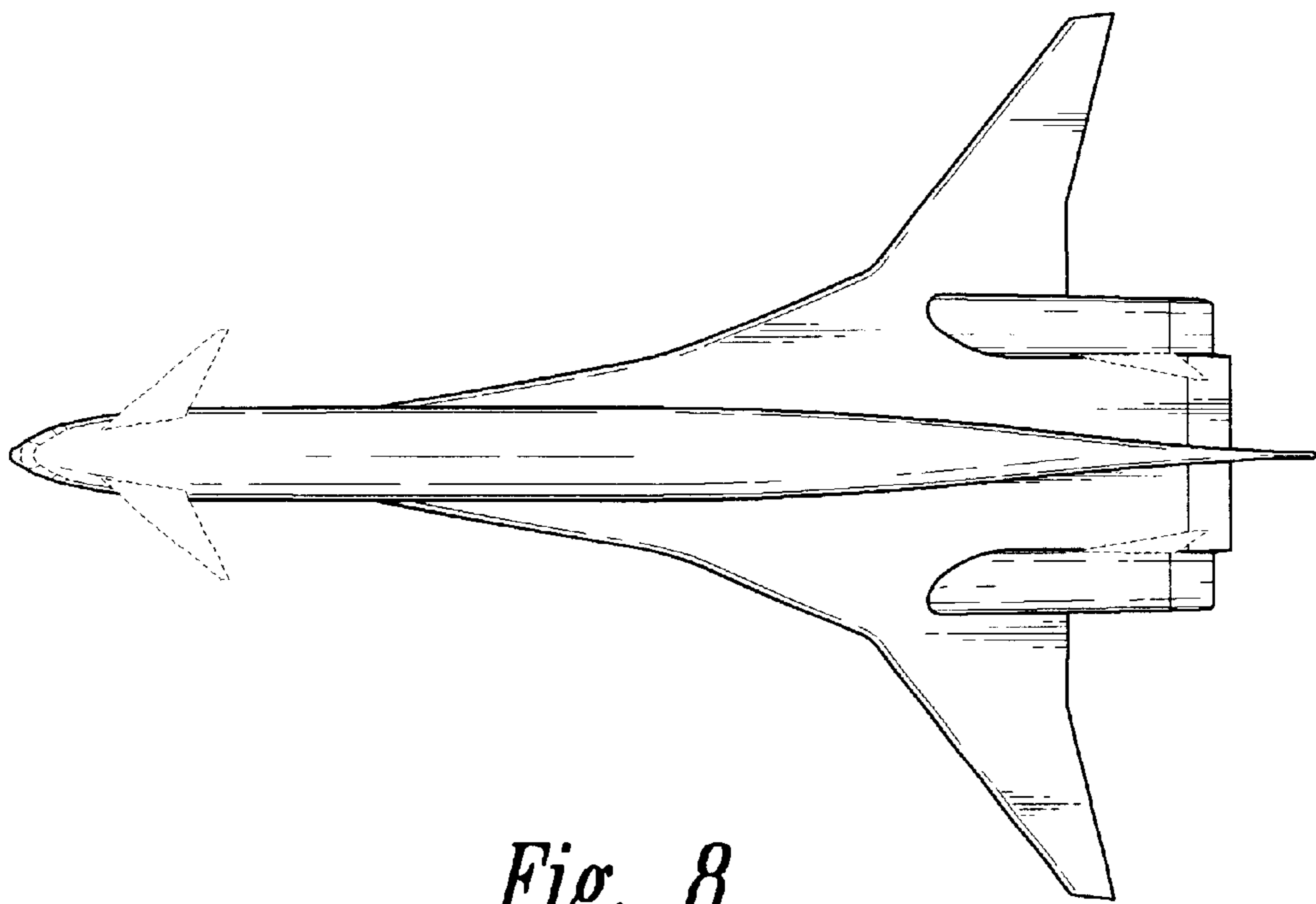

Fig. 8

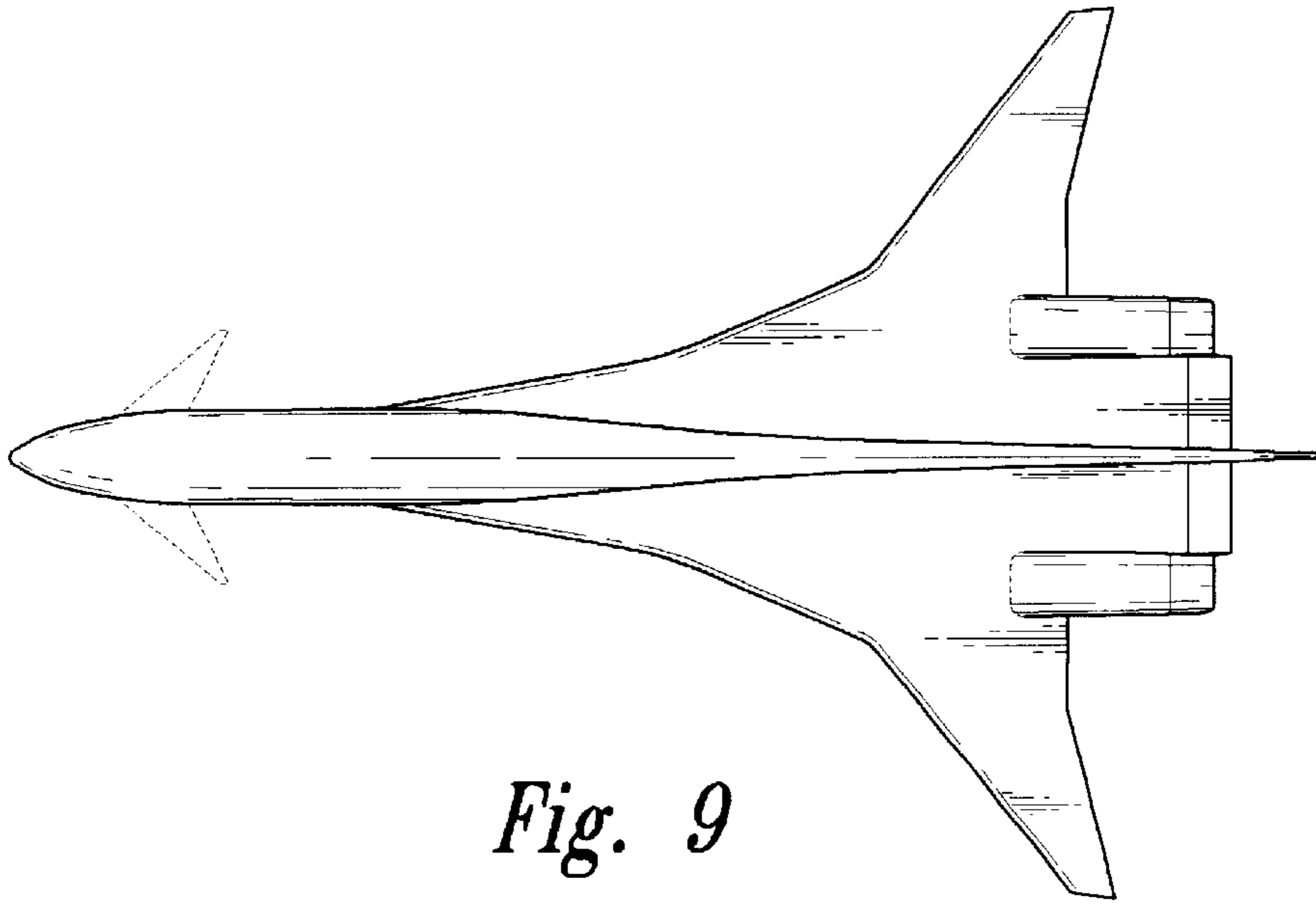

Fig. 9

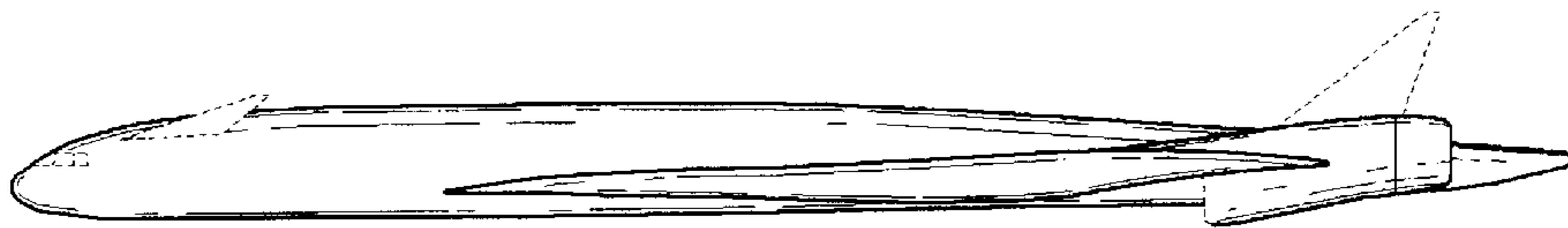

Fig. 10

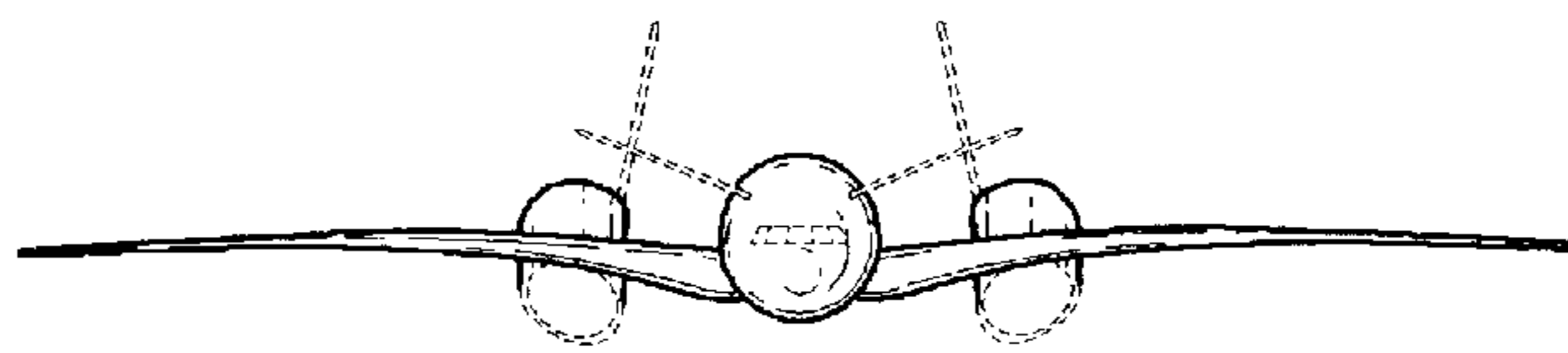

Fig. 11

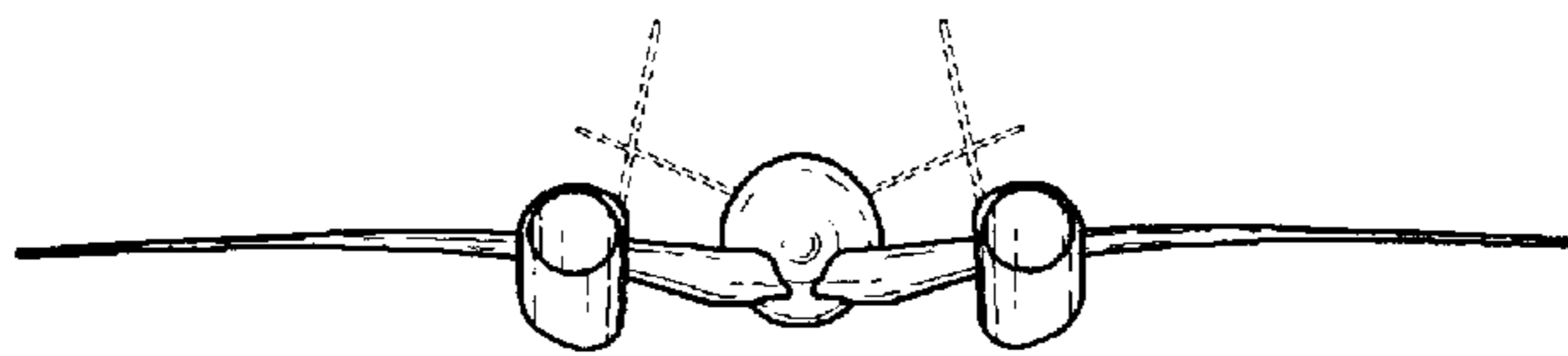

Fig. 12

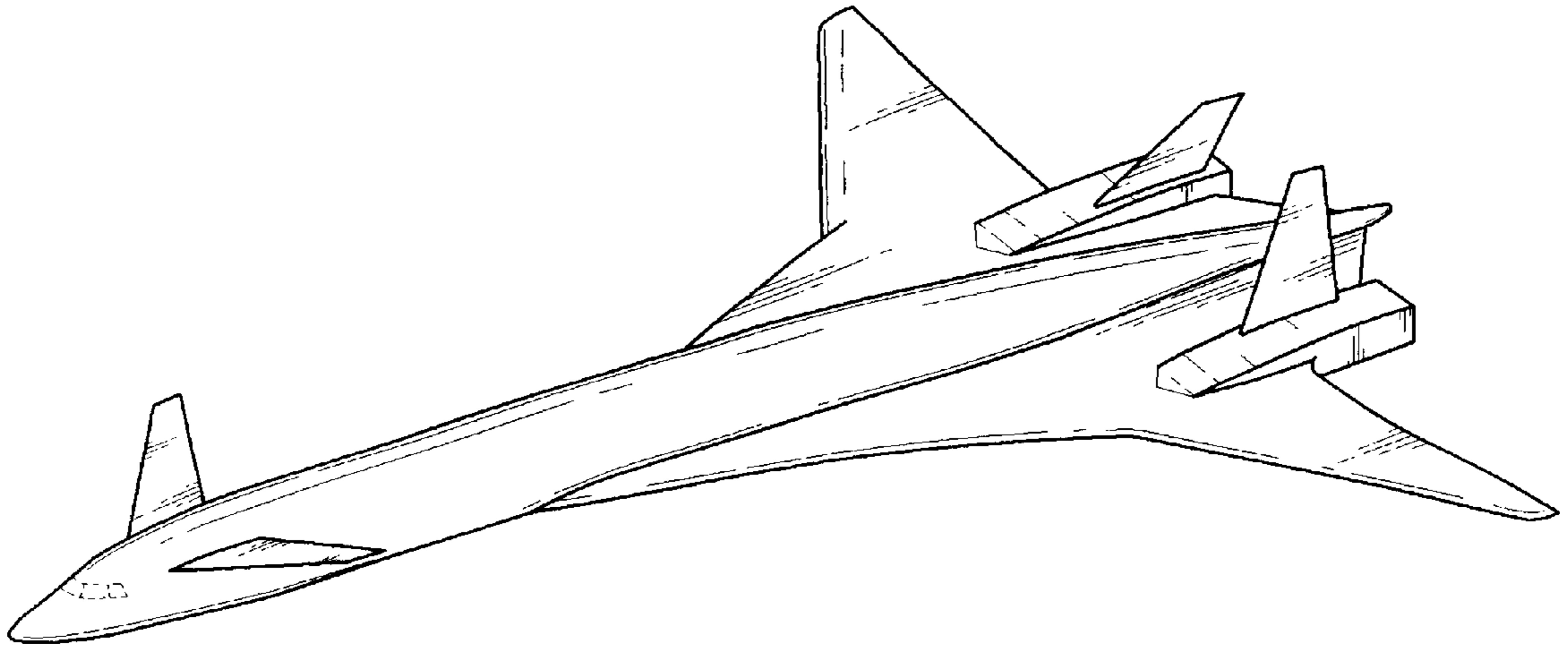

Fig. 13

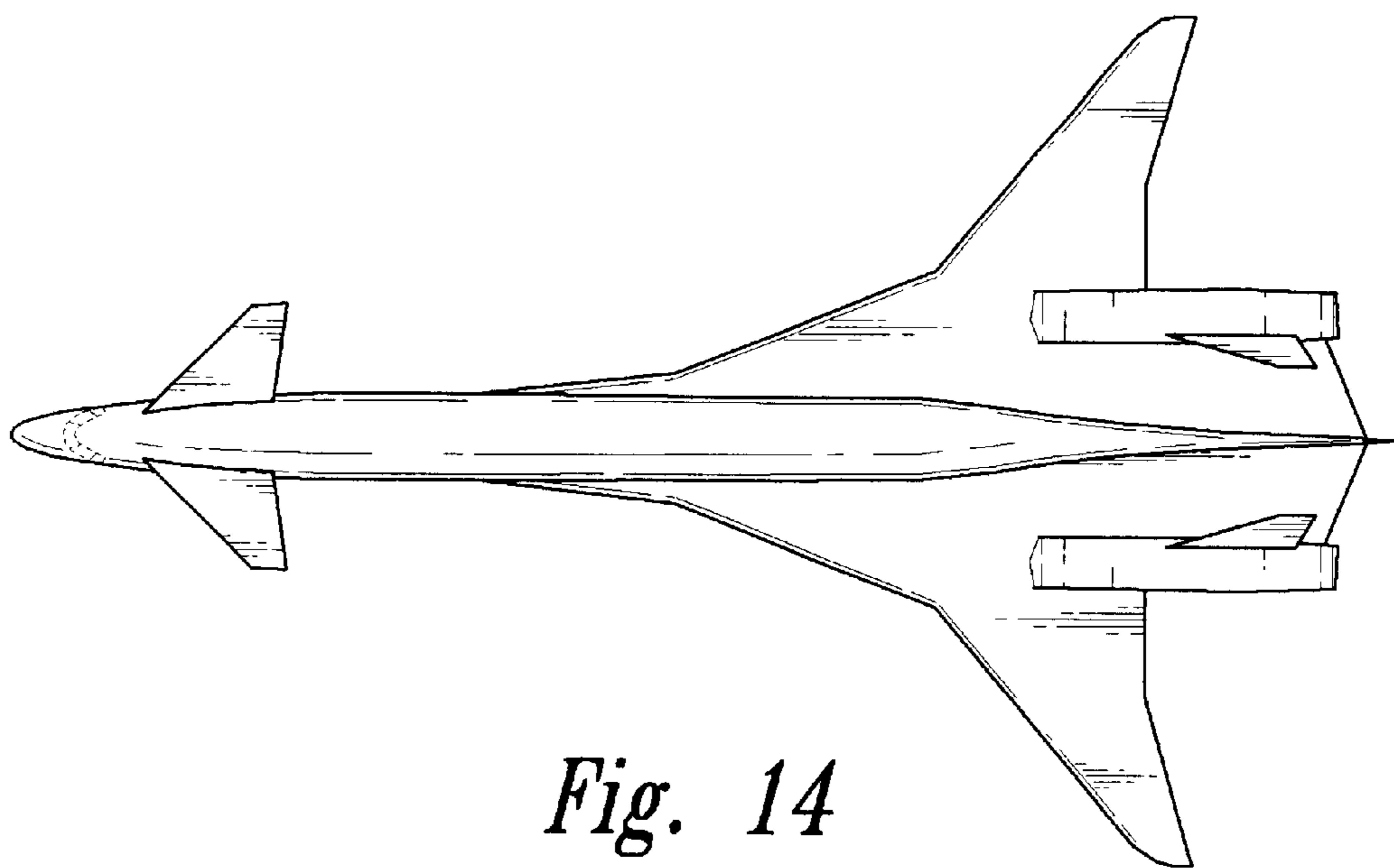

Fig. 14

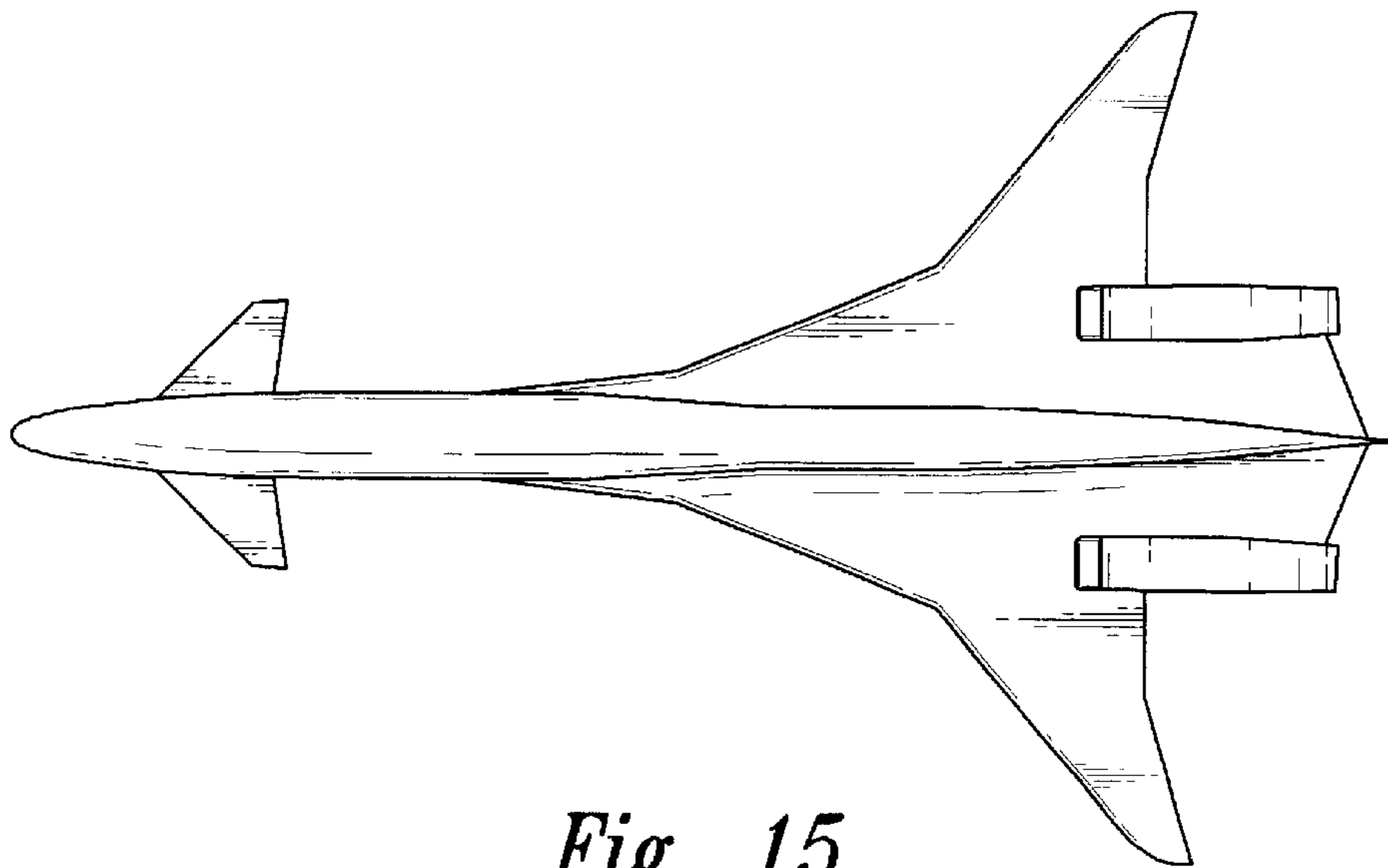

Fig. 15

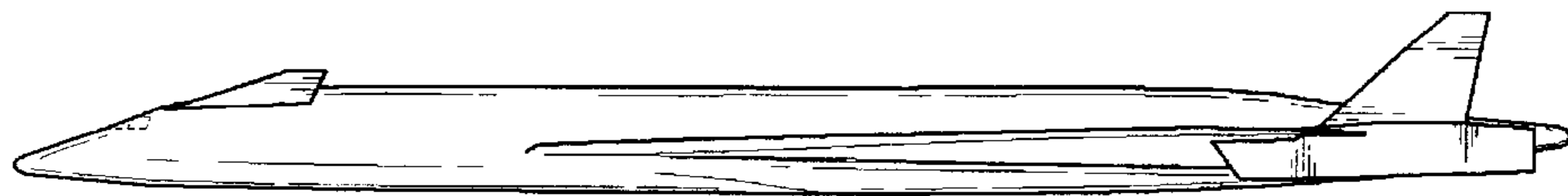

Fig. 16

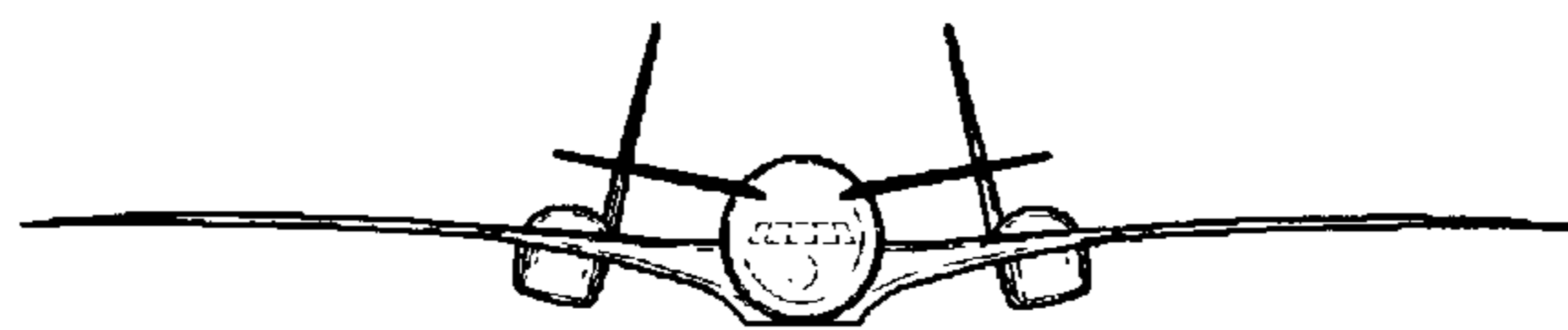

Fig. 17

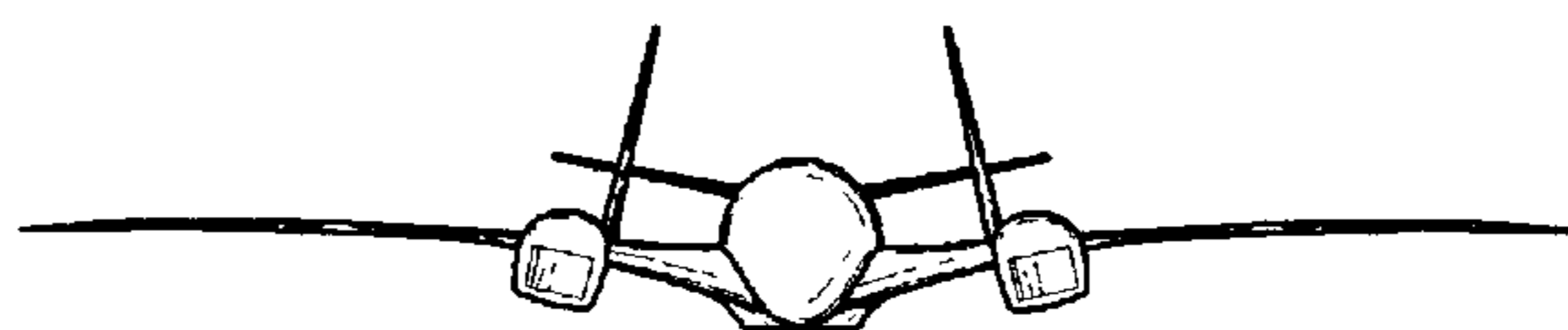

Fig. 18

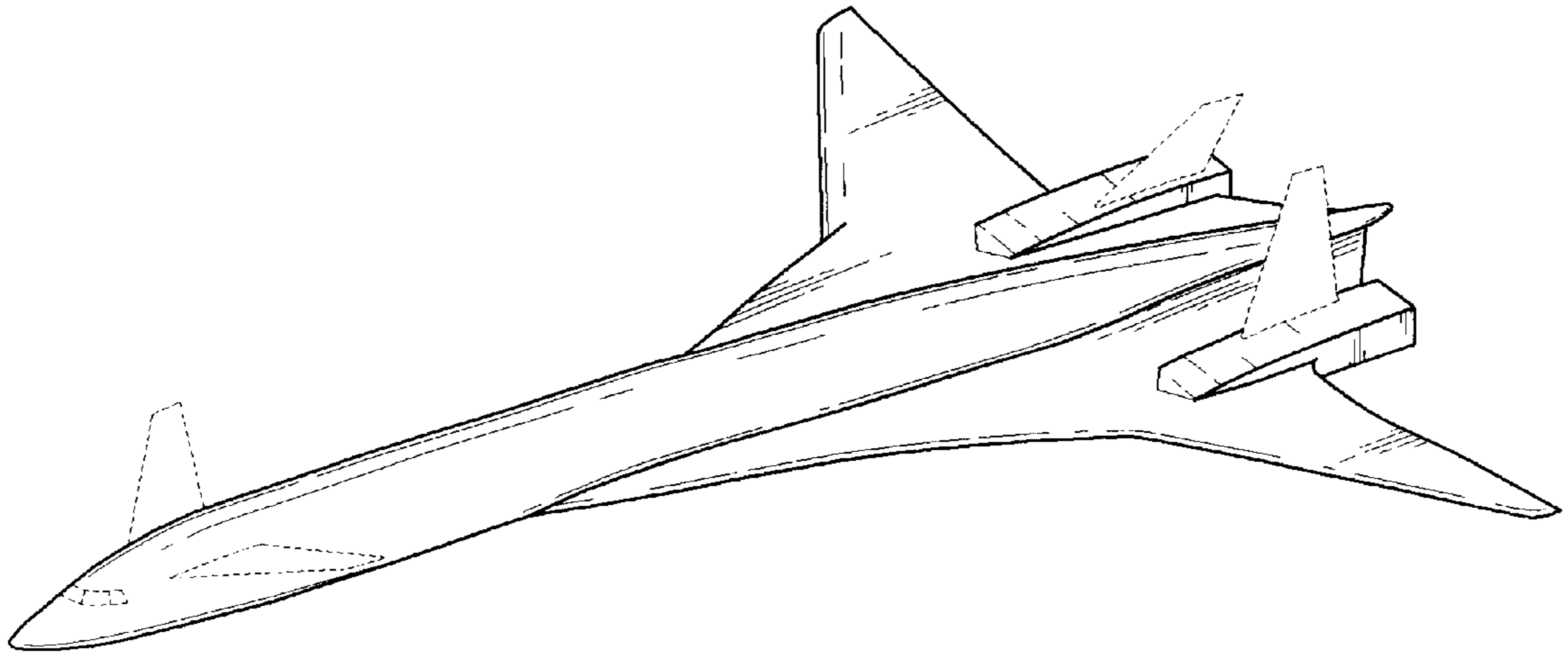

Fig. 19

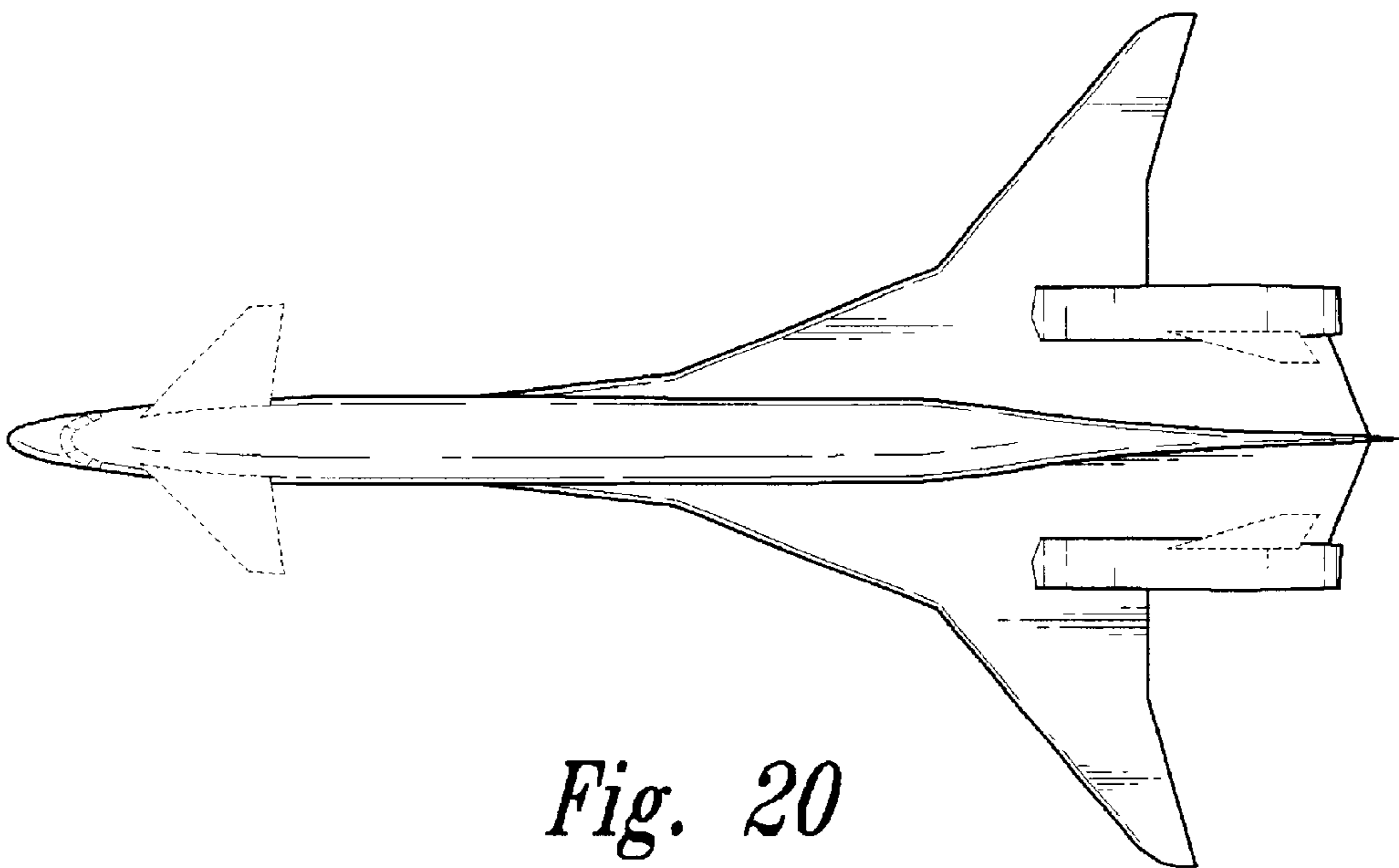

Fig. 20

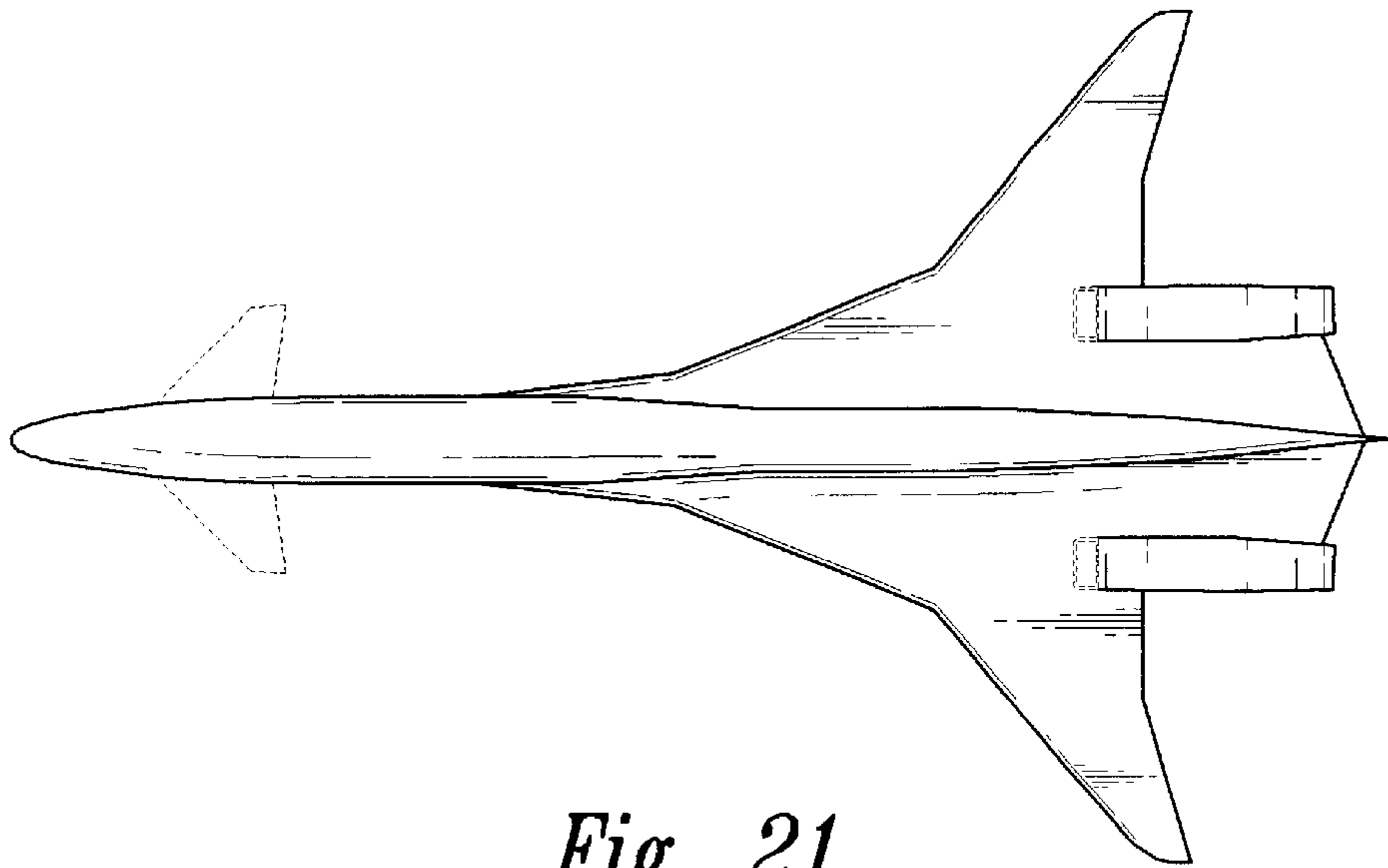

Fig. 21

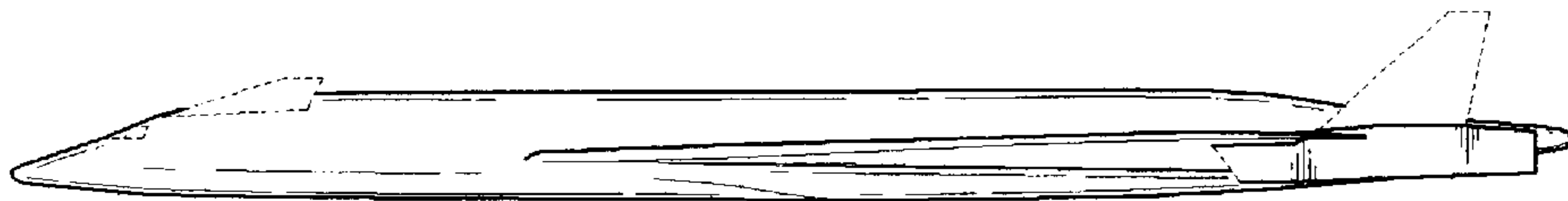

Fig. 22

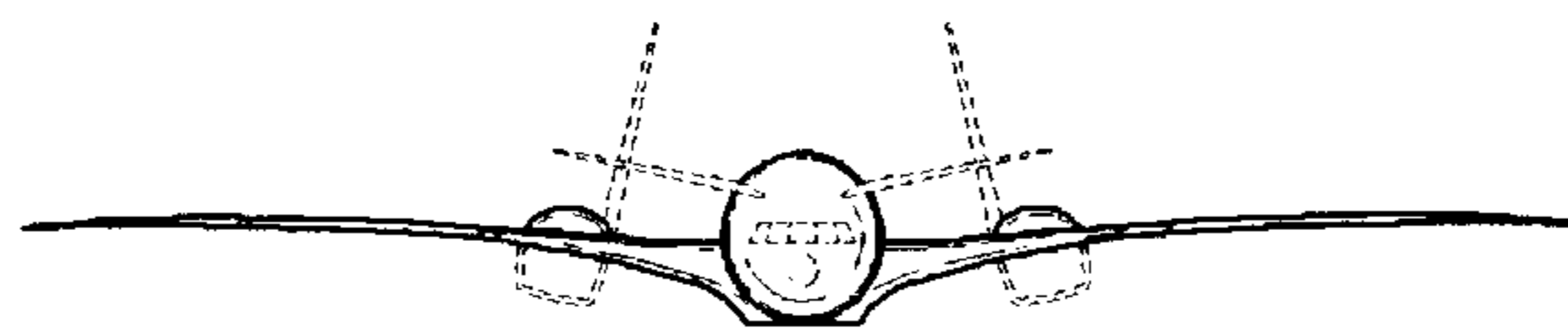

Fig. 23

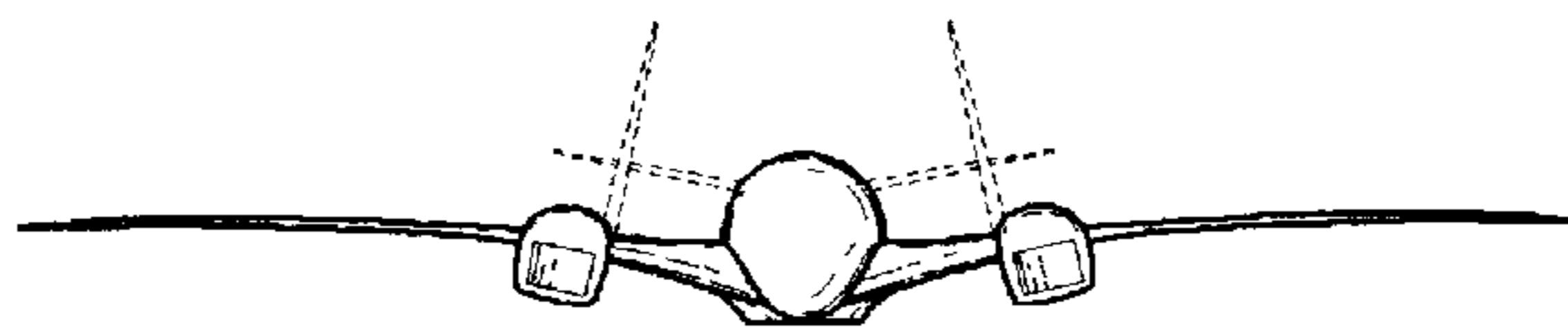

Fig. 24