



US00D479170S

(12) **United States Design Patent**
Boyer

(10) **Patent No.:** **US D479,170 S**
(45) **Date of Patent:** **** Sep. 2, 2003**

(54) **SURFACE CONFIGURATION OF A DOOR FOR A VEHICLE**

(75) Inventor: **Boyke Boyer**, Ismaning (DE)

(73) Assignee: **Bayerische Motoren Werke Aktiengesellschaft**, Munich (DE)

(**) Term: **14 Years**

(21) Appl. No.: **29/168,895**

(22) Filed: **Oct. 11, 2002**

(30) **Foreign Application Priority Data**

Apr. 16, 2002 (DE) 402 03 456

(51) **LOC (7) Cl.** **12-16**

(52) **U.S. Cl.** **D12/196**

(58) **Field of Search** D12/196, 90-92;
296/185

(56) **References Cited**

U.S. PATENT DOCUMENTS

- D387,025 S * 12/1997 Lagaay et al. D12/196
- D418,471 S * 1/2000 Gabath D12/196
- D419,124 S * 1/2000 Sacco et al. D12/196
- D467,851 S * 12/2002 Warming D12/196

* cited by examiner

Primary Examiner—Melody N. Brown
(74) *Attorney, Agent, or Firm*—Crowell & Moring LLP

(57) **CLAIM**

The ornamental design for a surface configuration of a door for a vehicle, as shown and described.

DESCRIPTION

This application is related to co-pending application Ser. No. 29/168,898, of the inventor, entitled "Surface Configuration of a Vehicle, Toy and/or Other Replicas."

FIG. 1 is a front view of a first embodiment of a surface configuration of a door for a vehicle according to my novel design;

FIG. 2 is a perspective view of the first embodiment of the surface configuration of a door for a vehicle according to my novel design;

FIG. 3 is a perspective view of the first embodiment of the surface configuration of a door for a vehicle according to my novel design;

FIG. 4 is a front view of a second embodiment of the surface configuration of a door for a vehicle according to my novel design;

FIG. 5 is a perspective view of the second embodiment of the surface configuration of a door for a vehicle according to my novel design; and,

FIG. 6 is a perspective view of the second embodiment of the surface configuration of a door for a vehicle according to my novel design.

The dash lines included depict environment and are not part of the claimed design. Also enclosed is a set of photographs of an embodiment of my invention.

1 Claim, 2 Drawing Sheets

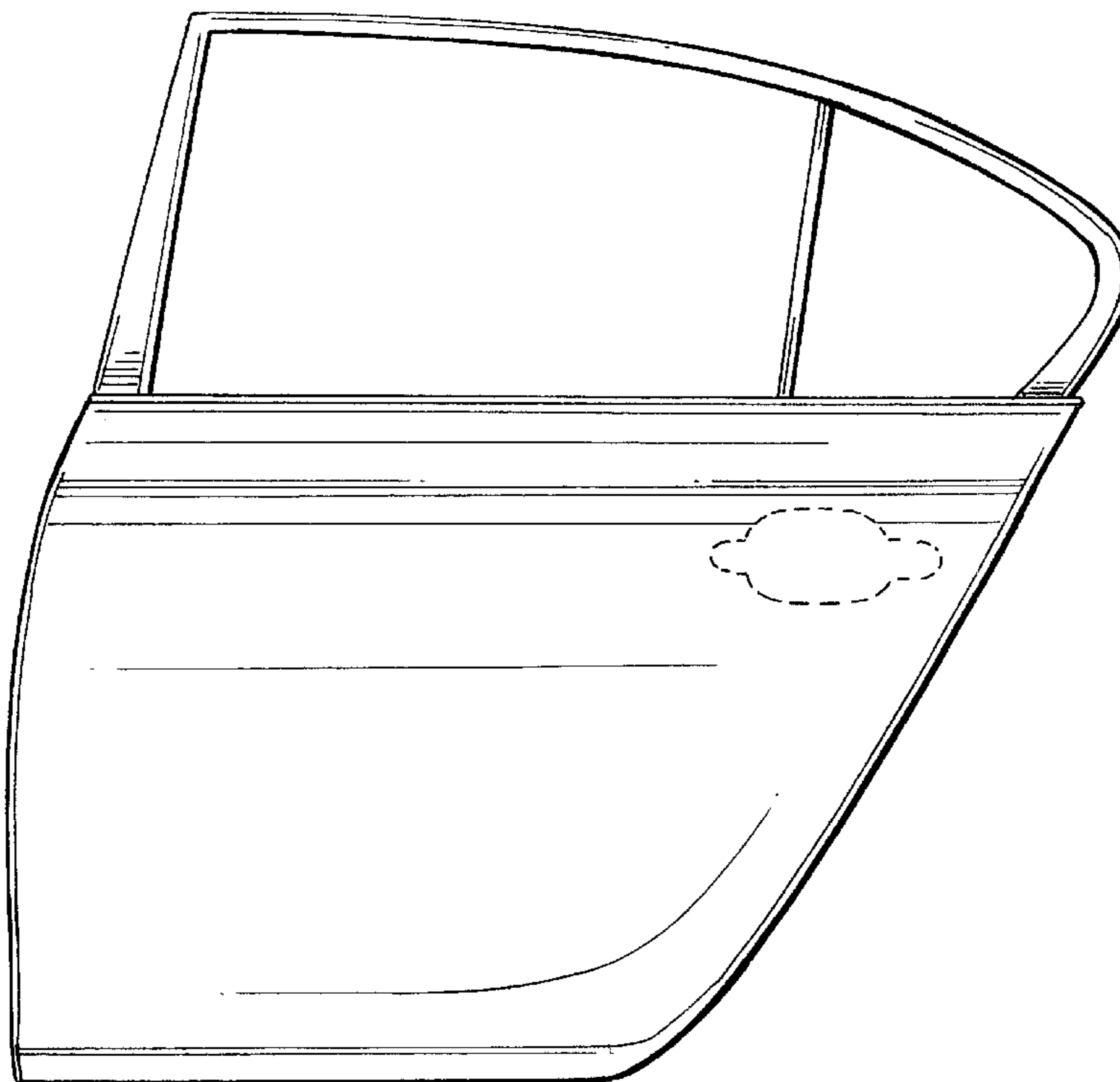

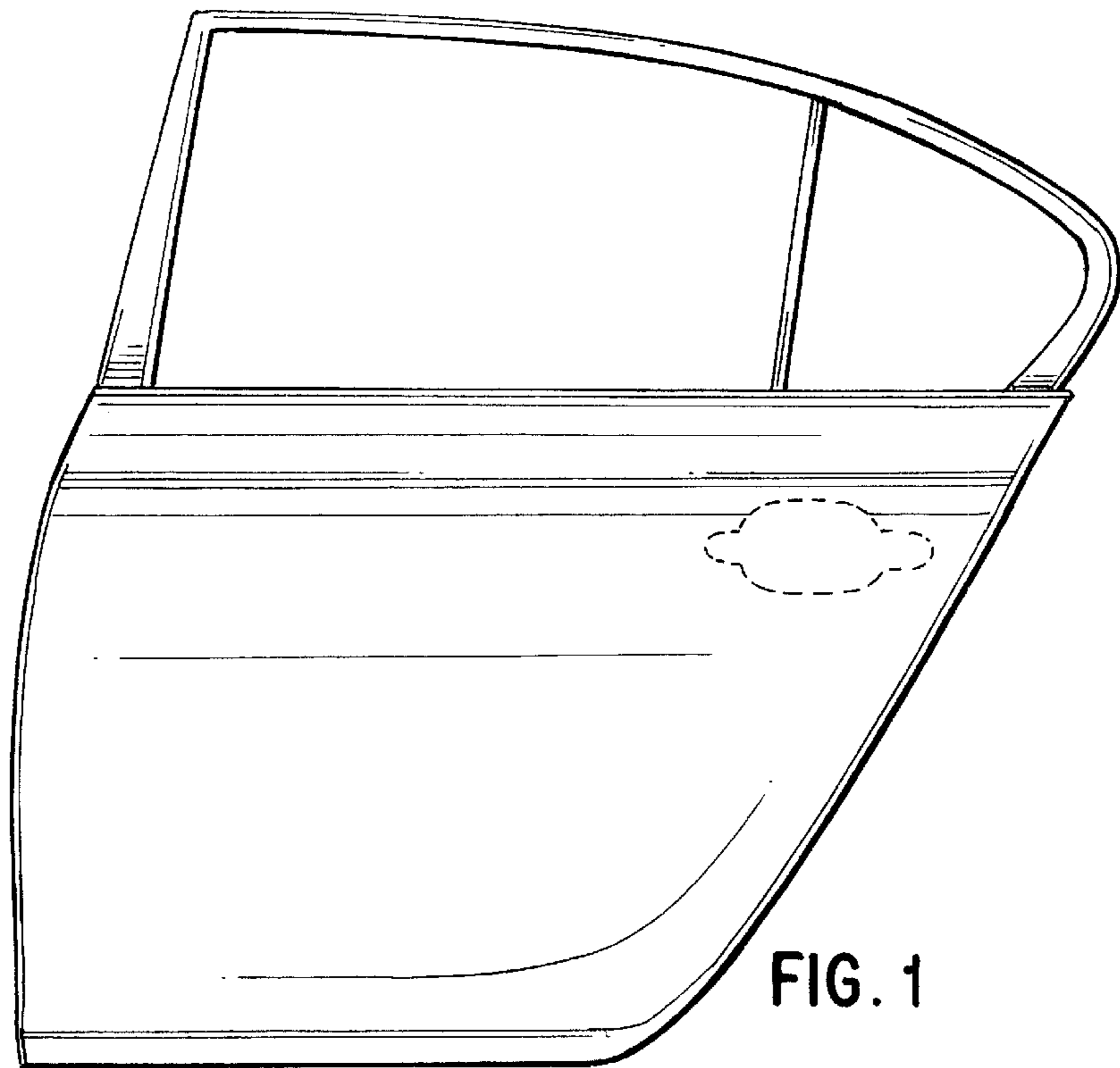

FIG. 1

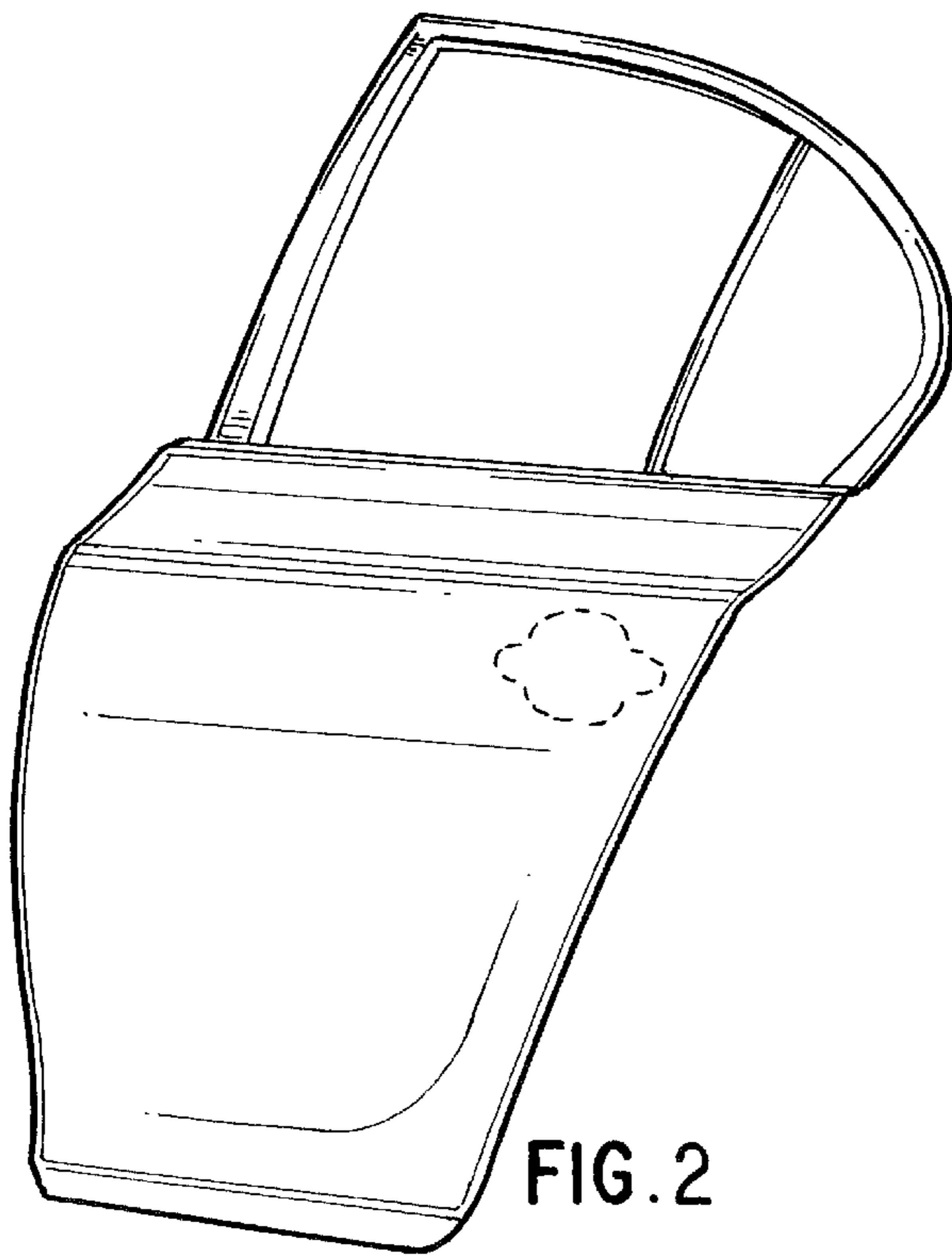

FIG. 2

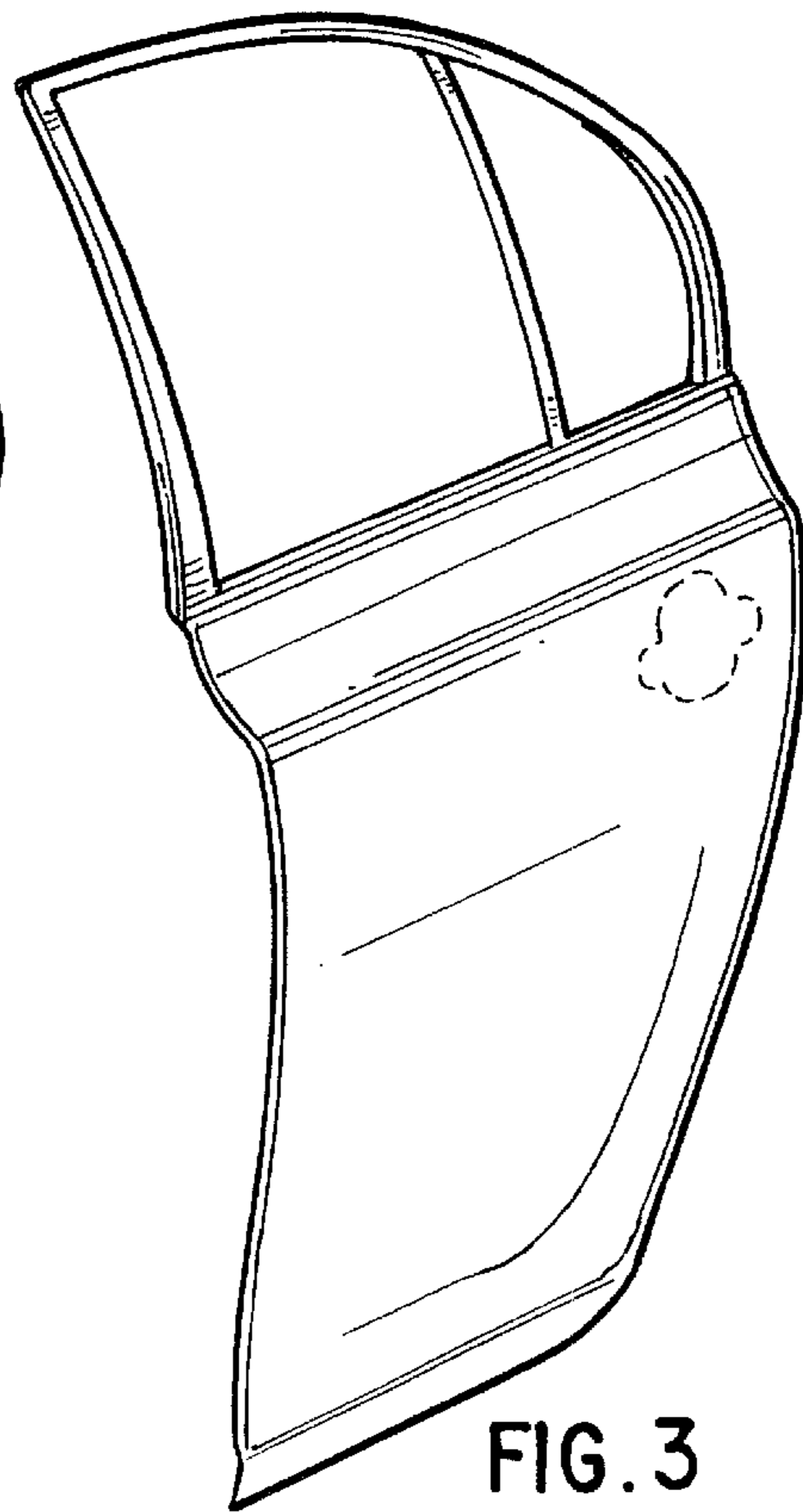

FIG. 3

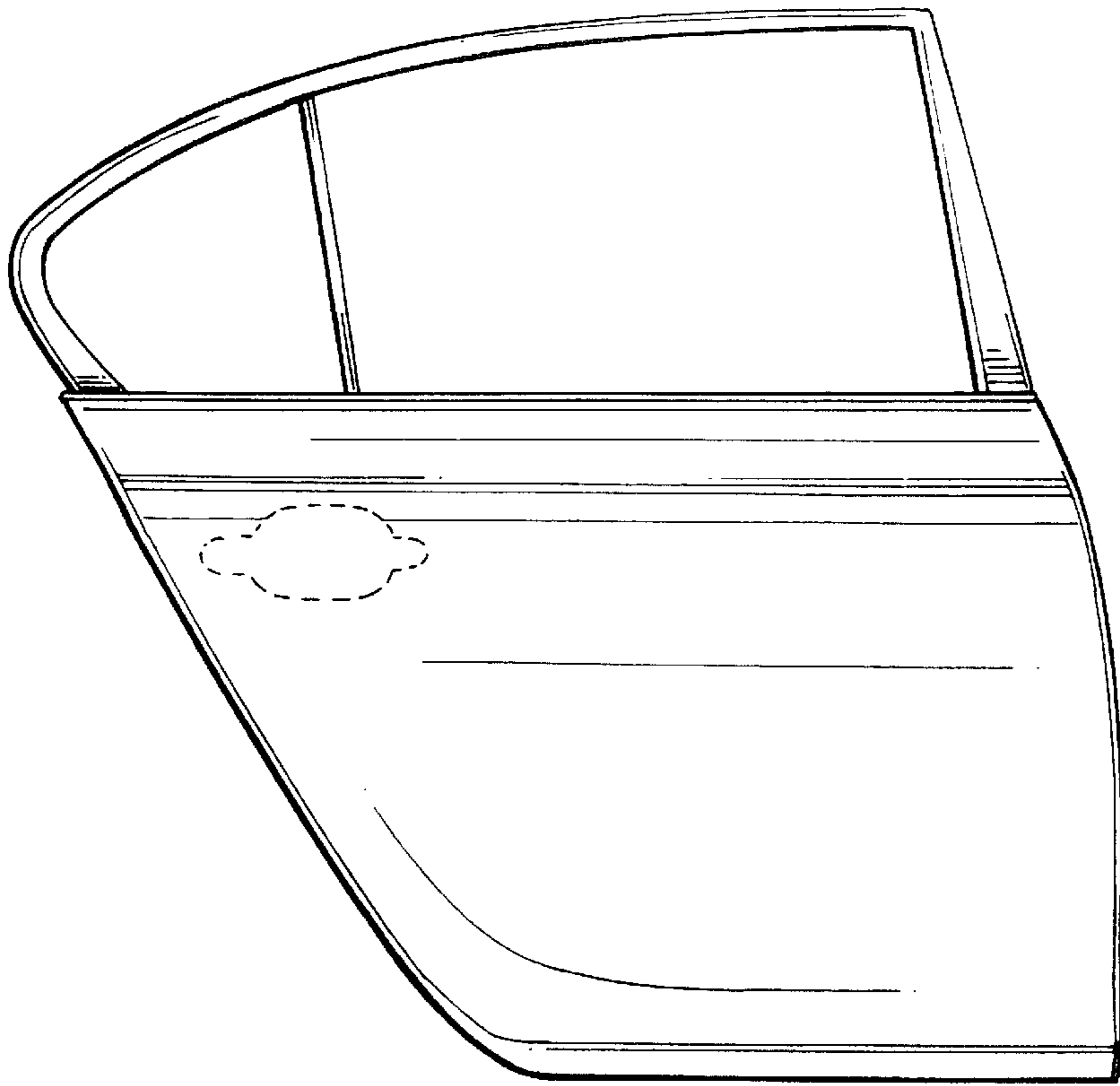

FIG. 4

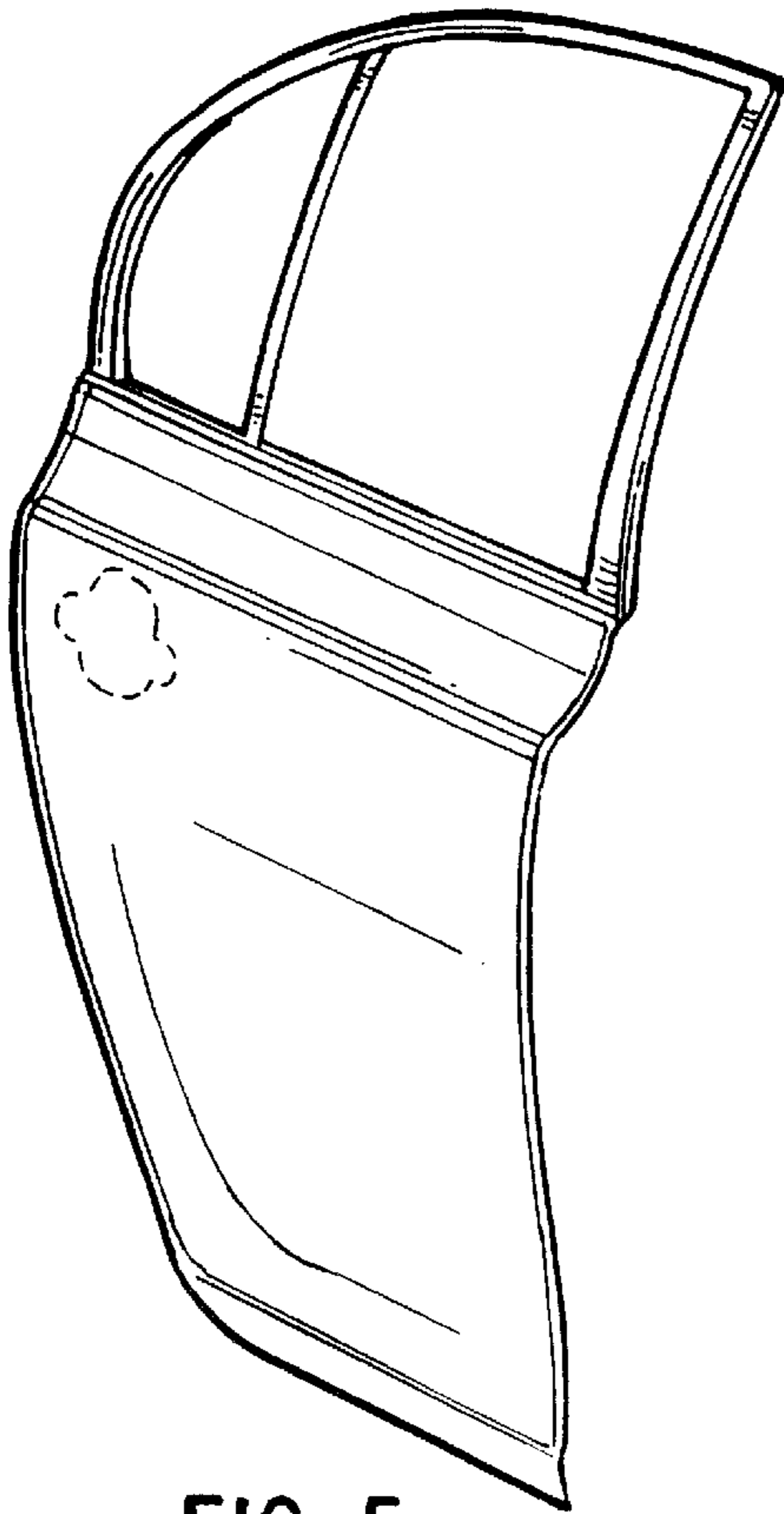

FIG. 5

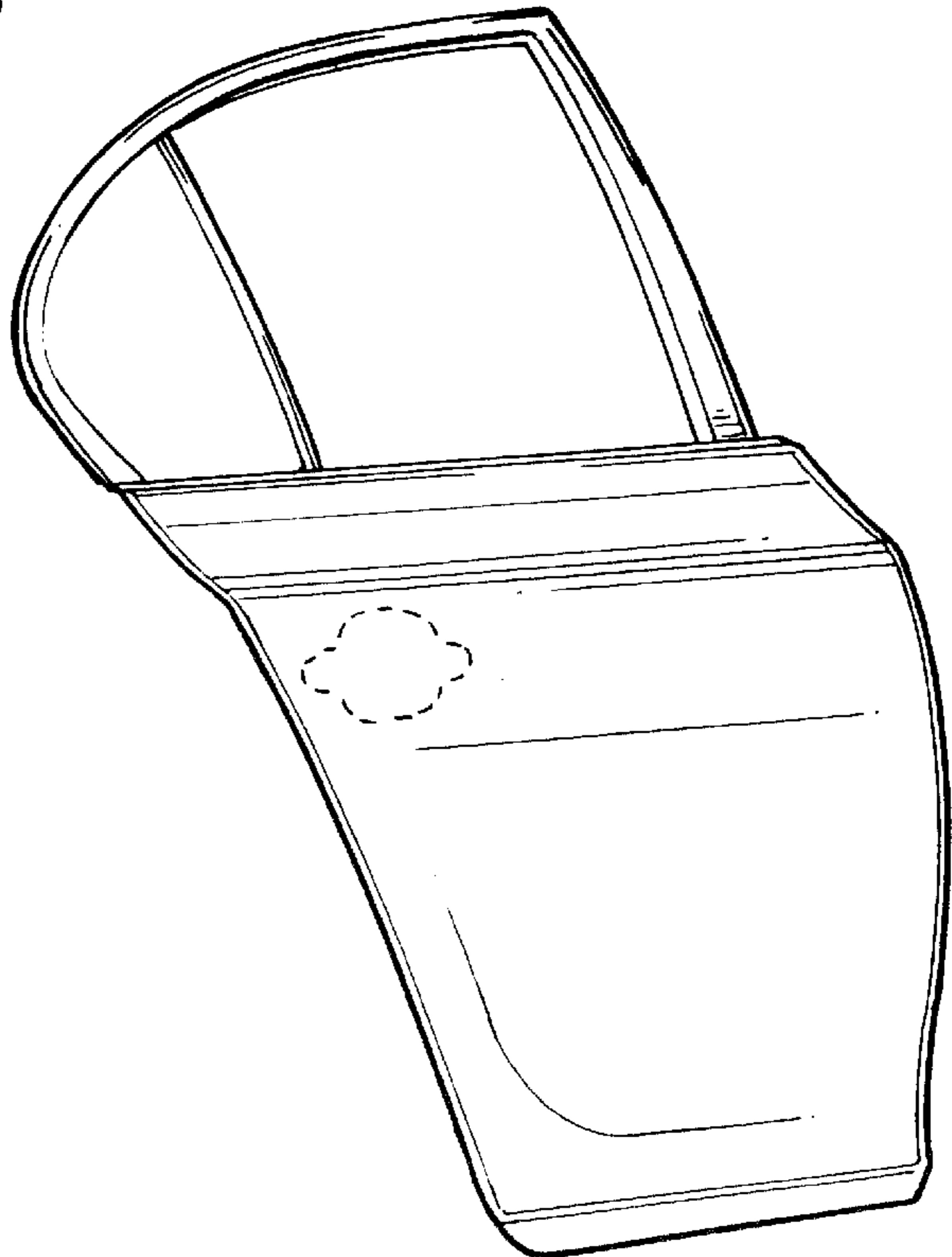

FIG. 6