



US00D478846S

(12) **United States Design Patent**
Sauter

(10) **Patent No.:** **US D478,846 S**

(45) **Date of Patent:** **** Aug. 26, 2003**

(54) **QUAD CYCLE**

(75) Inventor: **David Patrick Sauter**, Carver, MN
(US)

(73) Assignee: **Studio 3D Incorporated**, Carver, MN
(US)

(**) Term: **14 Years**

(21) Appl. No.: **29/157,589**

(22) Filed: **Mar. 20, 2002**

(51) **LOC (7) Cl.** **12-11**

(52) **U.S. Cl.** **D12/107**

(58) **Field of Search** D12/107, 111,
D12/112; 280/209, 221, 231, 234, 267

(56) **References Cited**

U.S. PATENT DOCUMENTS

D146,543 S	*	4/1947	Hecht	D12/107
D200,765 S	*	4/1965	Cooper	D12/107
3,561,778 A		2/1971	La Brie		
3,834,721 A		9/1974	Gobby		
3,843,145 A		10/1974	Templeton		
4,639,007 A	*	1/1987	Lawrence	280/234
D290,451 S		6/1987	Engum		
4,674,762 A		6/1987	Nelson et al.		
4,826,190 A		5/1989	Hartmann		
5,036,939 A		8/1991	Johnson et al.		
5,145,196 A		9/1992	Langkamp		
5,511,809 A		4/1996	Sagi		
6,170,844 B1		1/2001	Sasi		

FOREIGN PATENT DOCUMENTS

FR	1078044	11/1954
GB	2 001 142 A	1/1979
GB	2 125 745 A	3/1984

OTHER PUBLICATIONS

Exhibit A, "Discover New Worlds", Rhoades National Corporation, Henderson Tennessee, 1 page (Date Unknown, Publicly known prior to the date of filing of the present patent application.).

Exhibit B, "Hammacher Schlemmer, Offering the Best, the Only and the Unexpected for Over 149 Years" 1 page (Date Unknown, Publicly known prior to the date of filing of the present patent application.).

Exhibit C, "JT^B® Just Two Bikes[®]", White Bear Lake, Minnesota, 1 page (Date Unknown, Publicly known prior to the date of filing of the present patent application.).

Exhibit D, "Quad Cycle[™] E2 Sport Transport", 1 page (Date Unknown, Publicly known prior to the date of filing of the present patent application.).

Exhibit E, Brochures for "Lightfoot Cycle", "Karbon Kinetics International", "Cycles Maximus", AnthroTech Leichtfahrzeugetechni, "Inspired Cycle Engineering", "Advanced Vehicle Design", 6 pages (Date Unknown, Publicly known prior to the date of filing of the present patent application.).

* cited by examiner

Primary Examiner—Alan P. Douglas

Assistant Examiner—Linda Brooks

(74) *Attorney, Agent, or Firm*—Merchant & Gould P.C.

(57) **CLAIM**

The ornamental design for a quad cycle, as shown and described.

DESCRIPTION

FIG. 1 is a front perspective view of a quad cycle according to the principles of the present invention.

FIG. 2 is a top plan view of the quad cycle shown in FIG. 1.

FIG. 3 is a bottom plan view of the quad cycle shown in FIG. 1.

FIG. 4 is a right side elevational view of the quad cycle shown in FIG. 1.

FIG. 5 is a left side elevational view of the quad cycle shown in FIG. 1.

FIG. 6 is a rear elevational view of the quad cycle shown in FIG. 1; and,

FIG. 7 is a front elevational view of the quad cycle shown in FIG. 1.

1 Claim, 7 Drawing Sheets

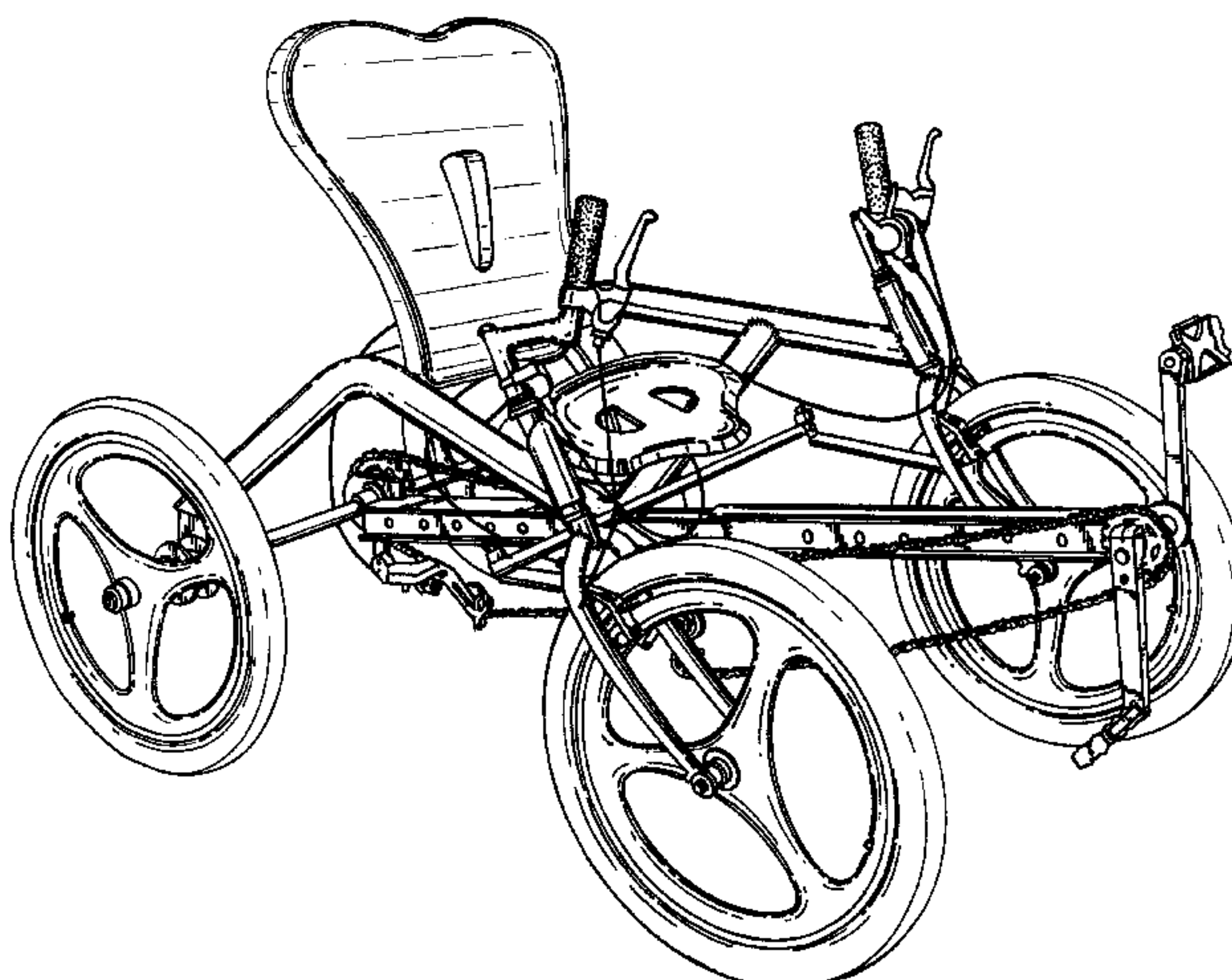

FIG. 1

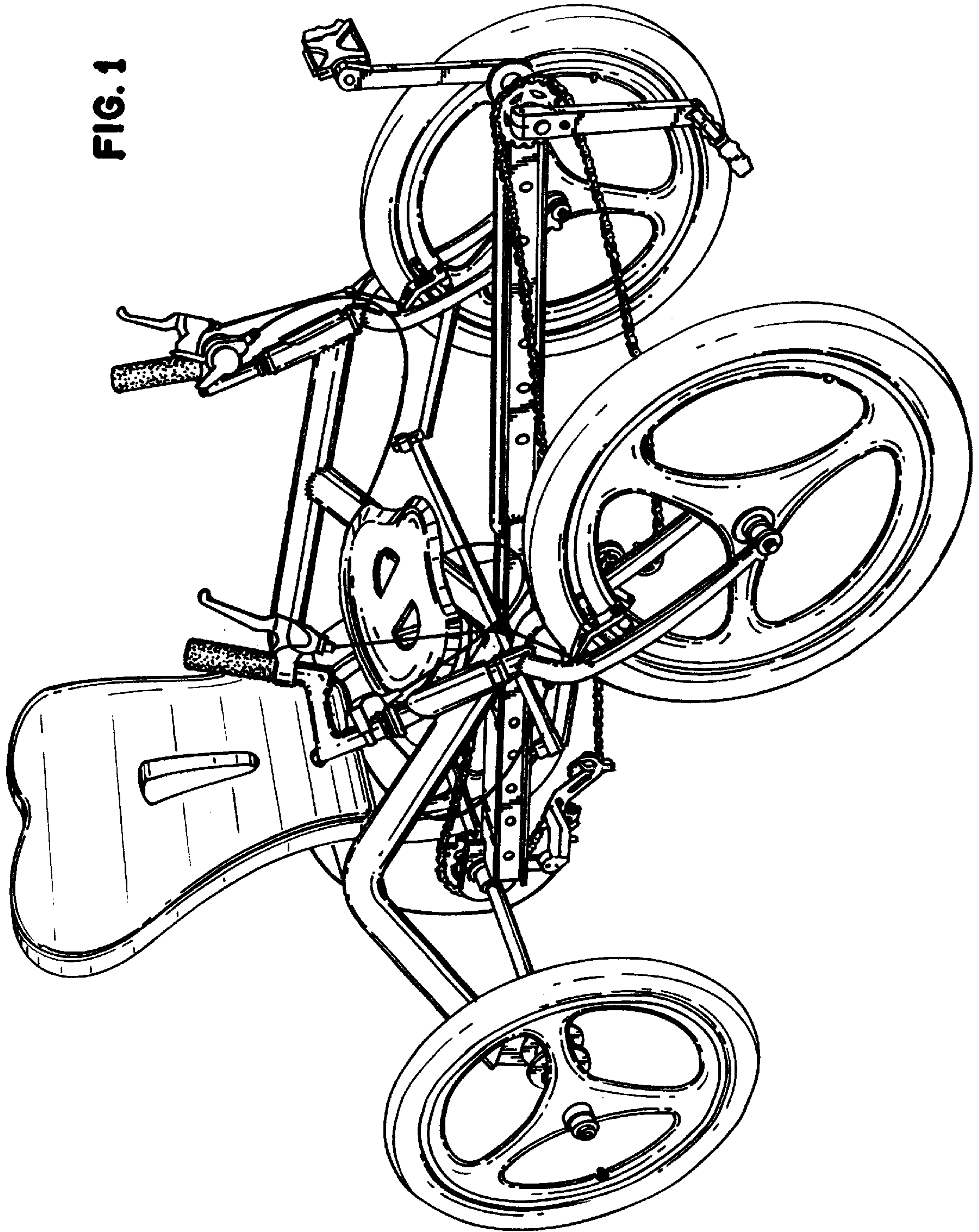

FIG. 2

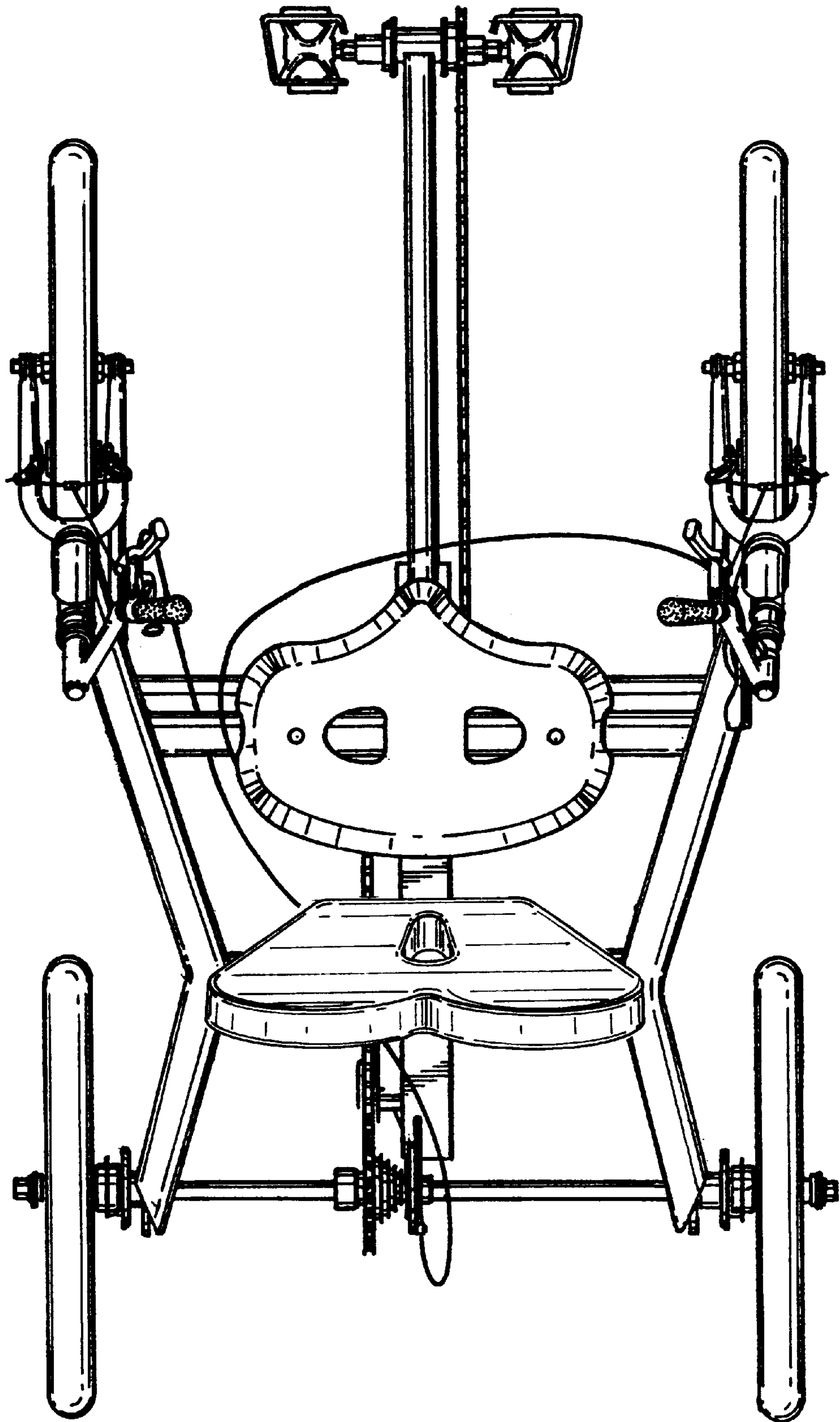

FIG. 3

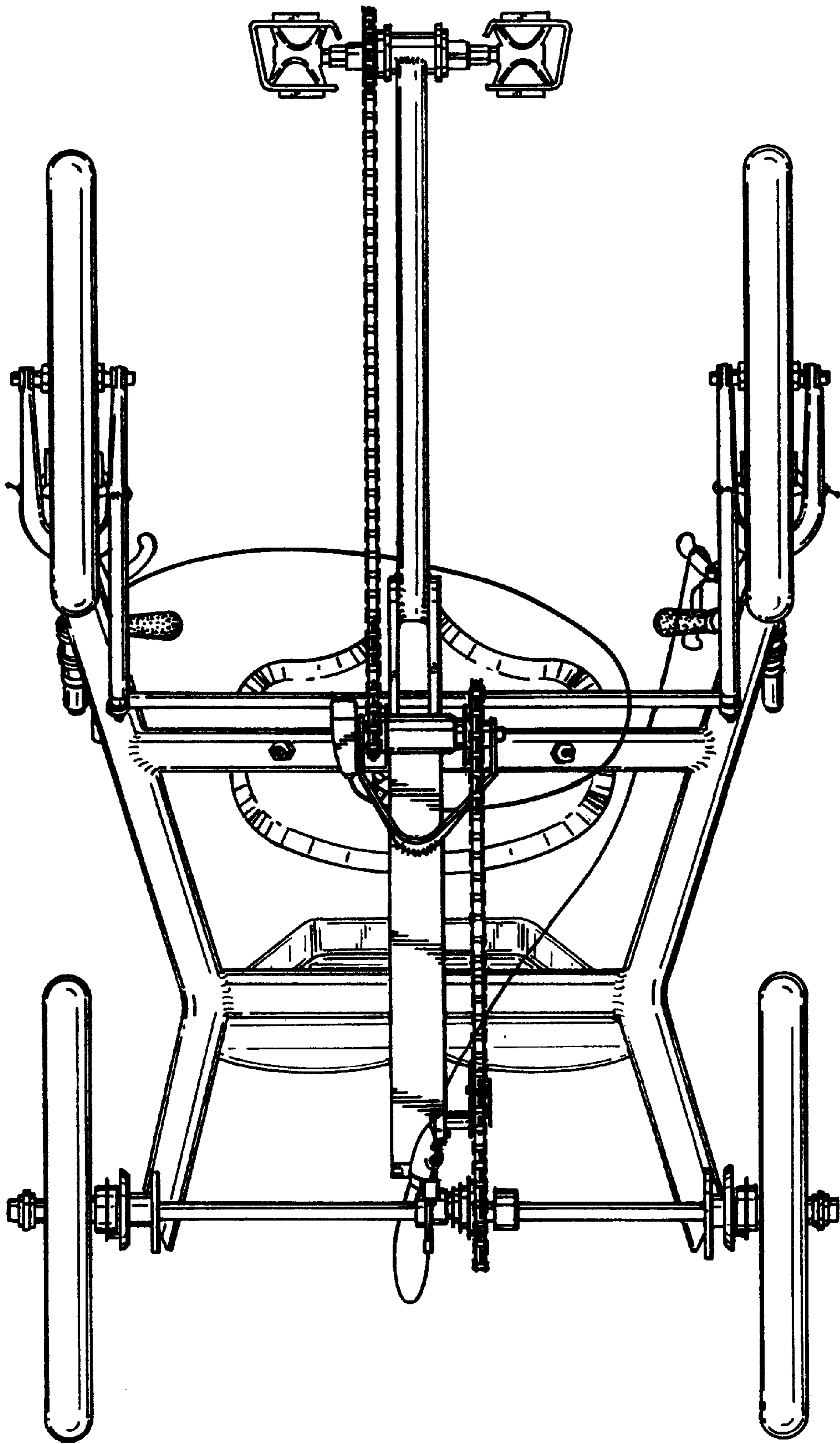
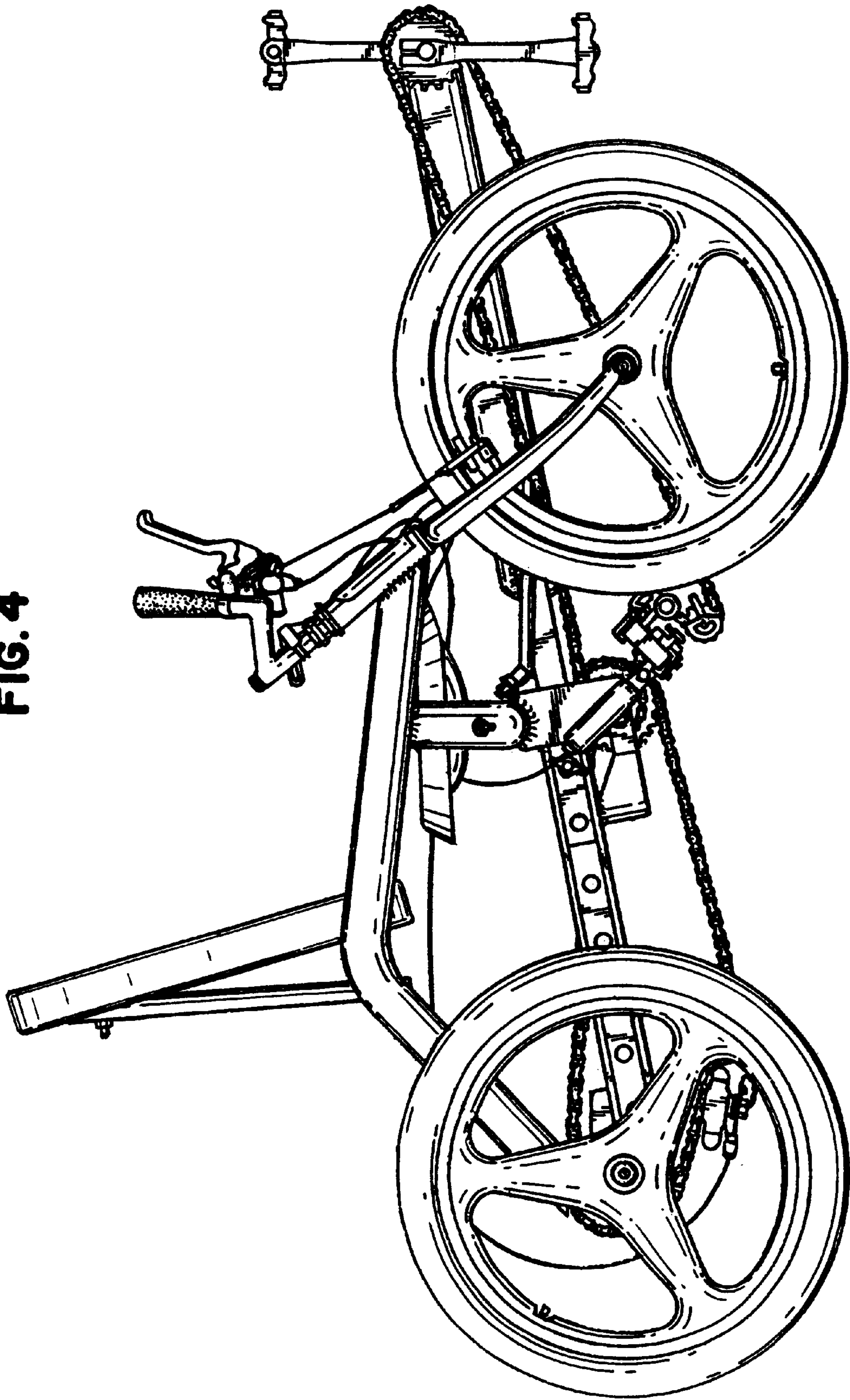

FIG. 4



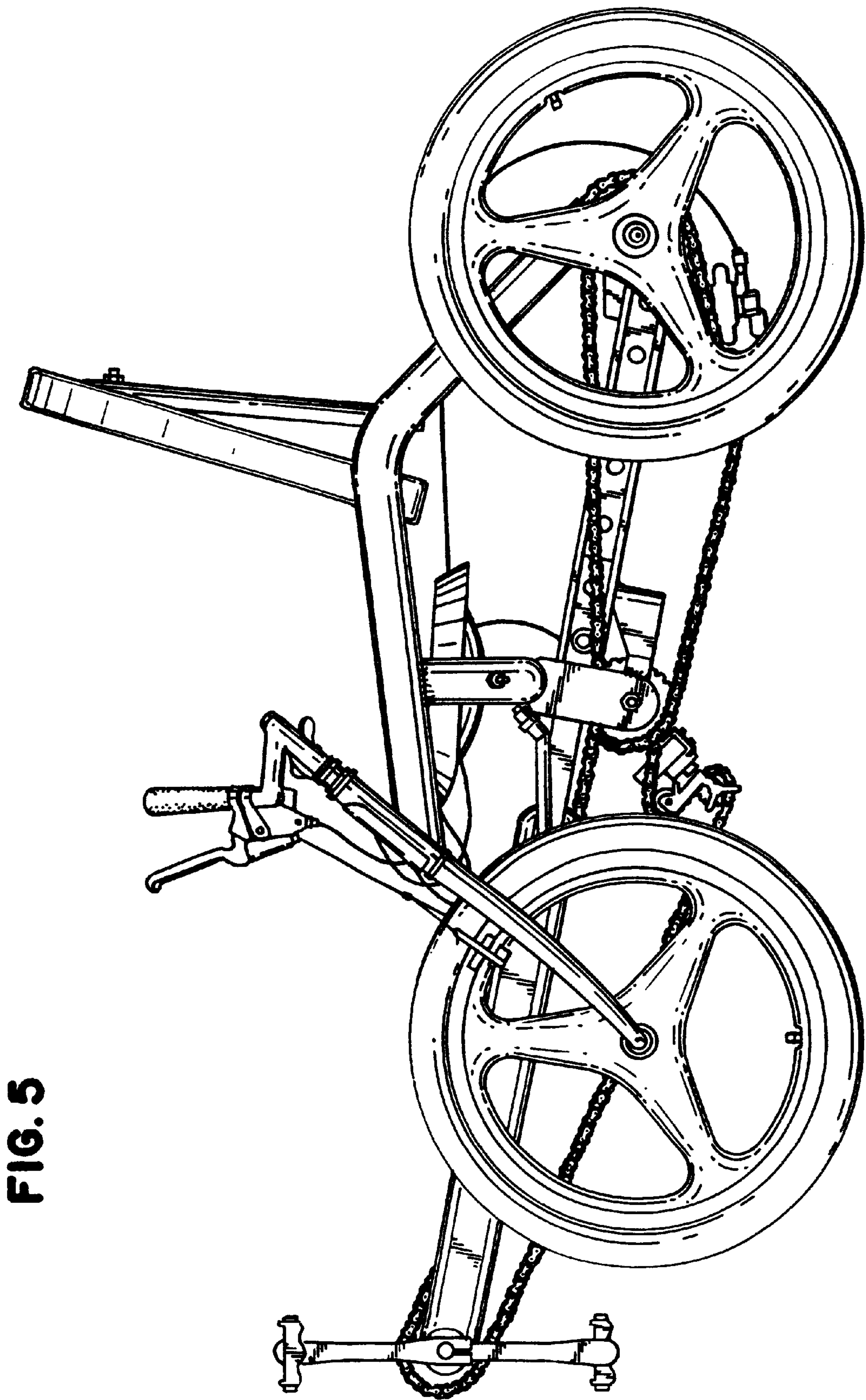

FIG. 5

FIG. 6

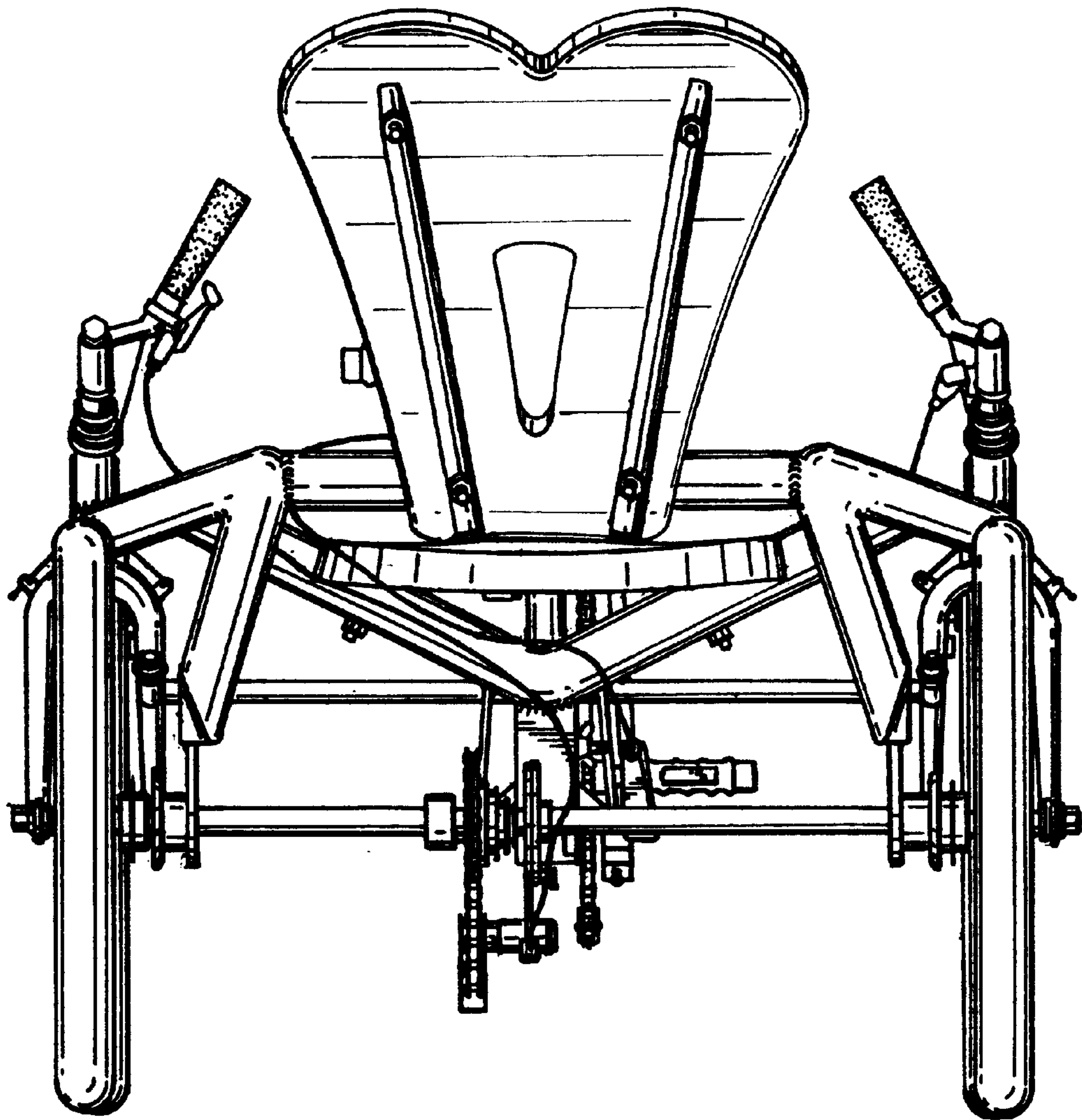

FIG. 7

