



US00D478843S

(12) **United States Design Patent**  
**Pardo**

(10) **Patent No.:** **US D478,843 S**

(45) **Date of Patent:** **\*\* Aug. 26, 2003**

(54) **VEHICLE**

D470,435 S \* 2/2003 Donckerwolke ..... D12/92

(75) Inventor: **Camilo Pardo**, Grosse Pointe Park, MI (US)

\* cited by examiner

(73) Assignee: **Ford Global Technologies, LLC**, Dearborn, MI (US)

*Primary Examiner*—Melody N. Brown

(74) *Attorney, Agent, or Firm*—Gigette M. Bejin

(\*\*) Term: **14 Years**

(57) **CLAIM**

The ornamental design for a vehicle, as shown and described.

(21) Appl. No.: **29/173,052**

**DESCRIPTION**

(22) Filed: **Dec. 23, 2002**

(51) **LOC (7) Cl.** ..... **12-08**

(52) **U.S. Cl.** ..... **D12/92**

(58) **Field of Search** ..... D12/90-92, 86, D12/88; 296/185

FIG. 1 is a perspective view of the vehicle;

FIG. 2 is a right side view of FIG. 1;

FIG. 3 is a front view of FIG. 1;

FIG. 4 is a rear view of FIG. 1; and,

FIG. 5 is a top view of FIG. 1.

The portions of the vehicle shown in broken lines are for illustrative purposes only and form no part of the claimed design.

The bottom view forms no part of the claimed design.

(56) **References Cited**

**U.S. PATENT DOCUMENTS**

D449,254 S \* 10/2001 Larson ..... D12/92

D458,872 S \* 6/2002 Ramaciotti ..... D12/92

**1 Claim, 3 Drawing Sheets**

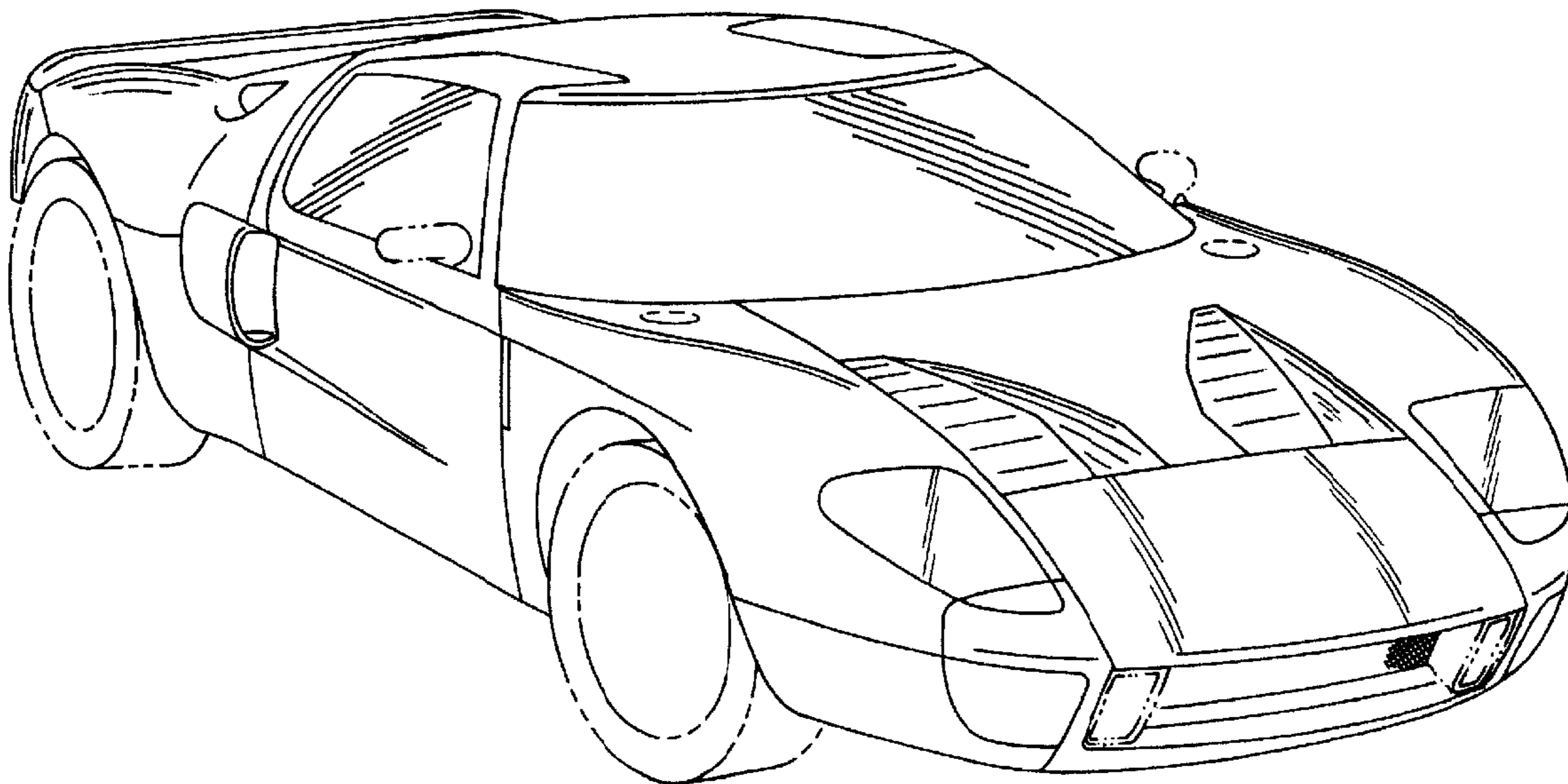

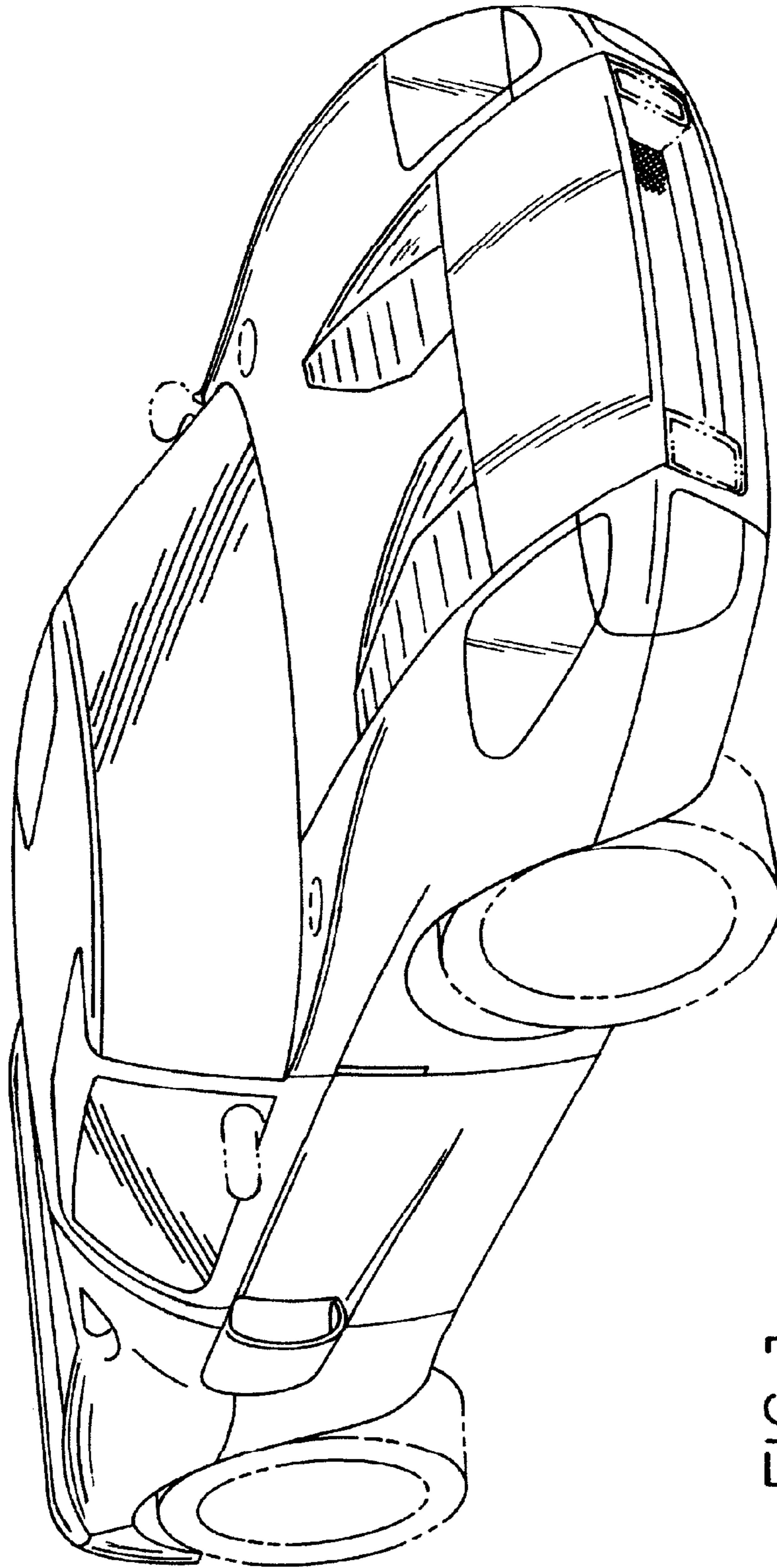

FIG. 1

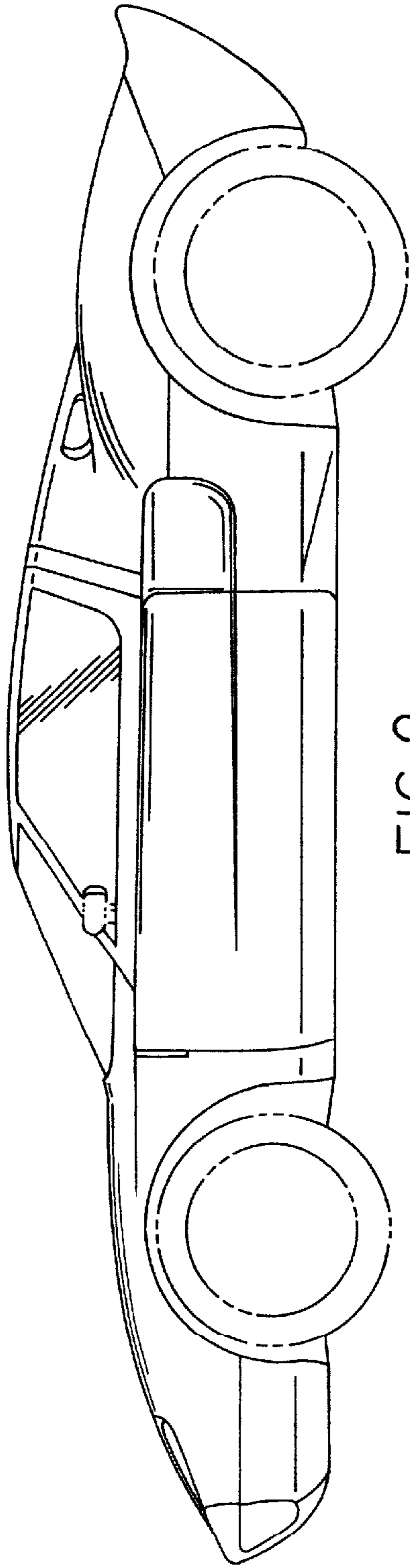

FIG. 2

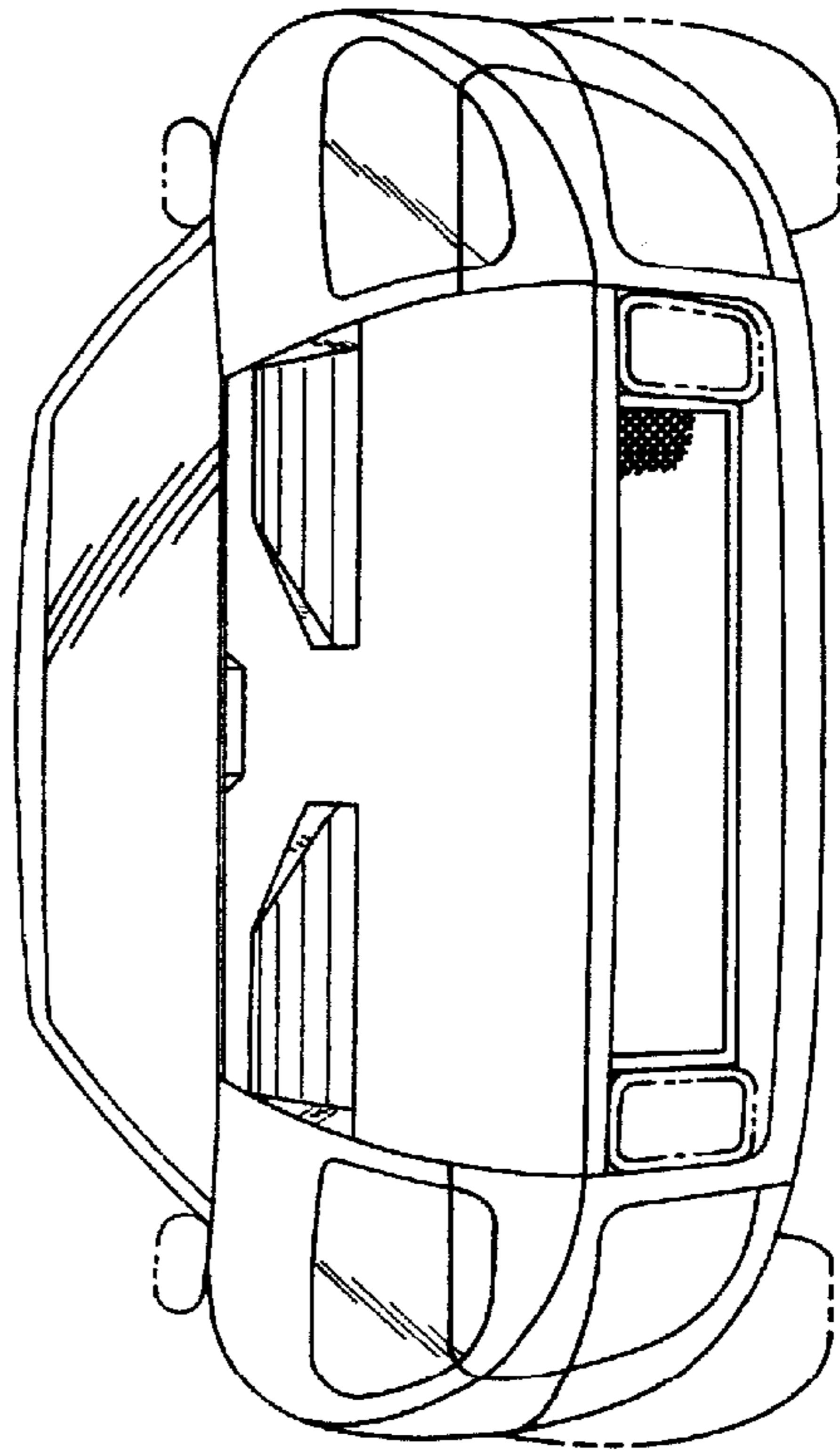

FIG. 3

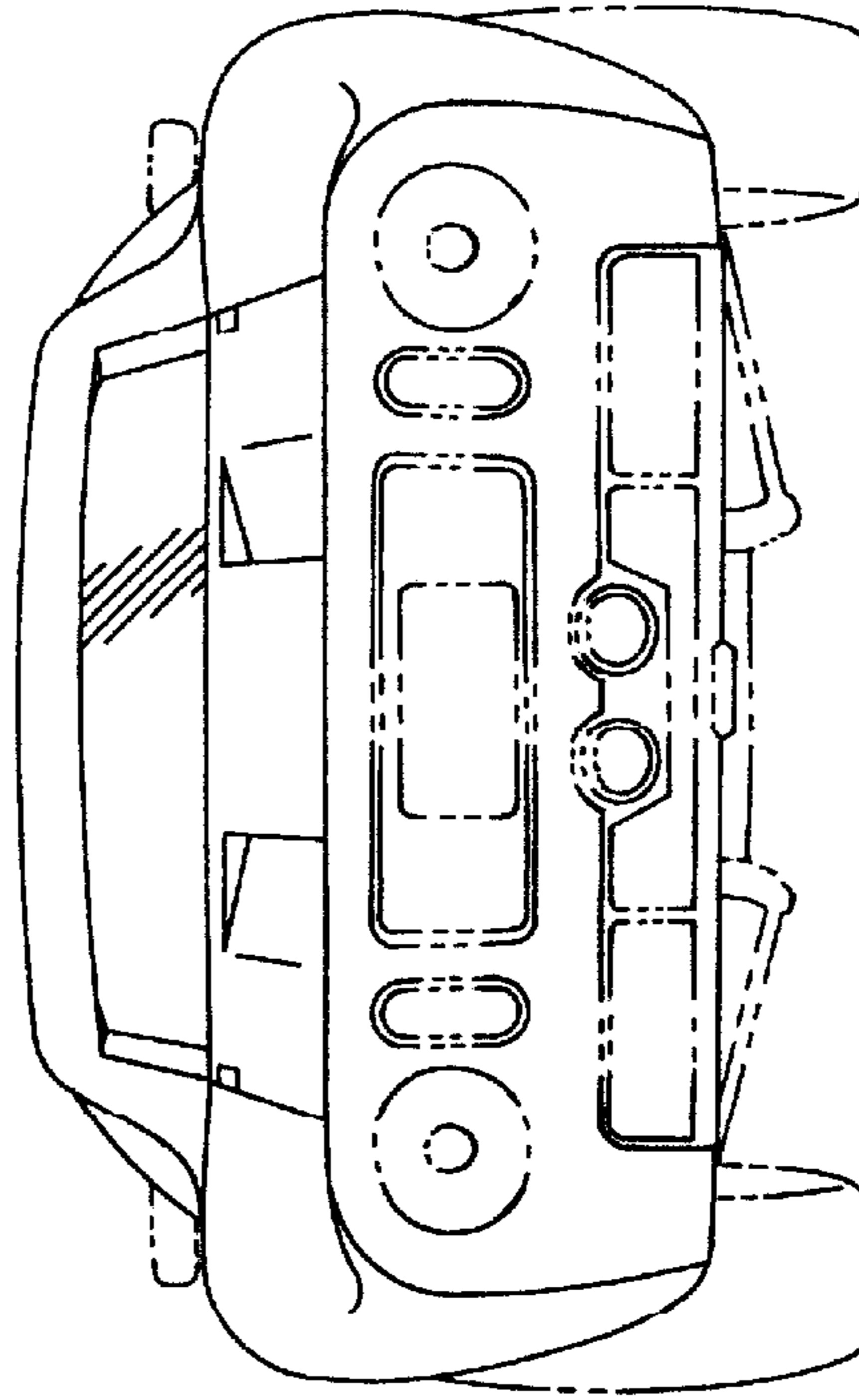

FIG. 4

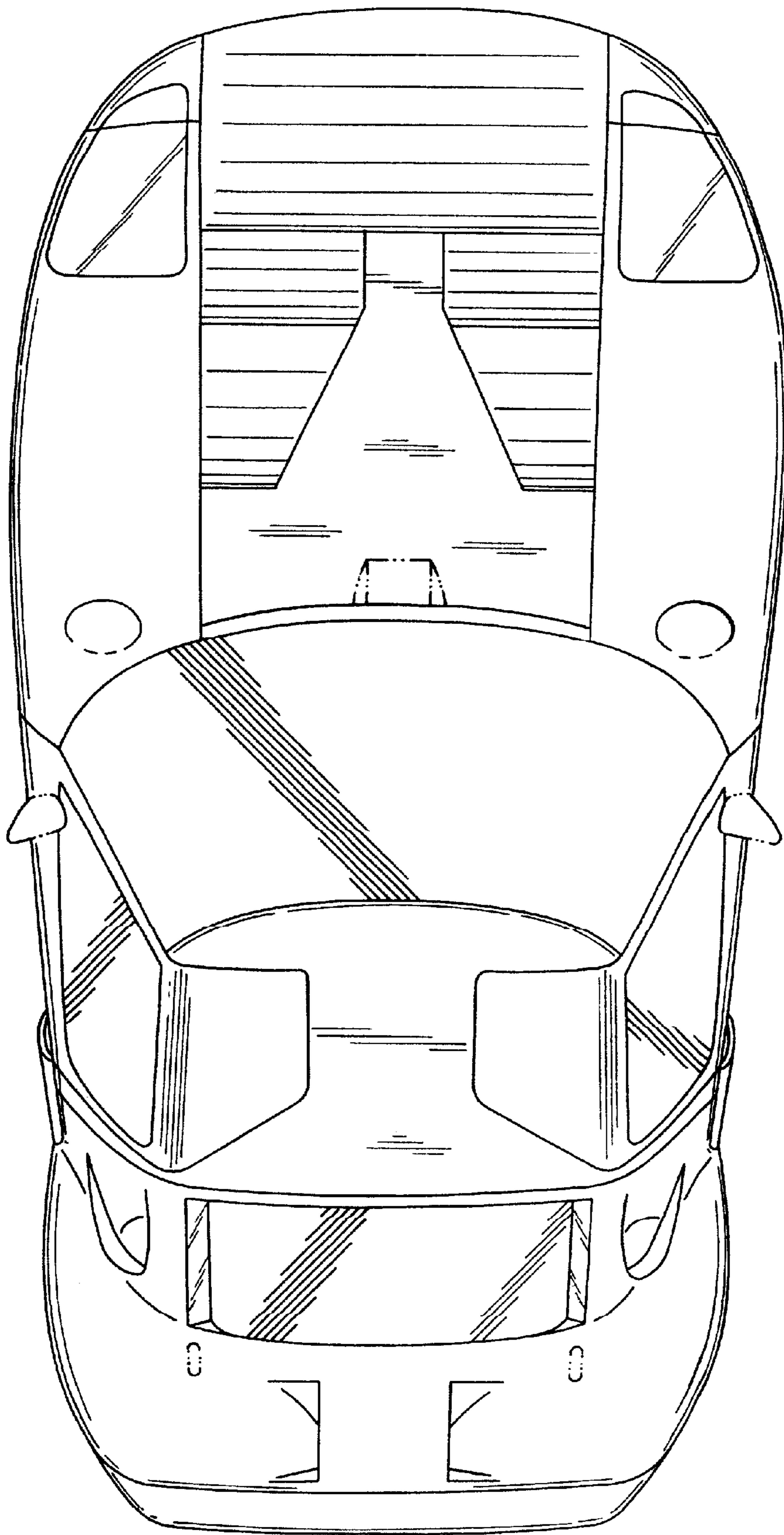

FIG. 5