



US00D478801S

(12) **United States Design Patent**  
**Spruill**

(10) **Patent No.:** **US D478,801 S**

(45) **Date of Patent:** **\*\* Aug. 26, 2003**

(54) **RAIL AND FENCE BRACKET APPARATUS**

(76) Inventor: **James F. Spruill**, 4600 Sears Rd.,  
Pegram, TN (US) 37143

(\*\*) Term: **14 Years**

(21) Appl. No.: **29/171,594**

(22) Filed: **Nov. 25, 2002**

**Related U.S. Application Data**

(62) Division of application No. 09/643,613, filed on Aug. 22,  
2000.

(51) **LOC (7) Cl.** ..... **08-05**

(52) **U.S. Cl.** ..... **D8/354**

(58) **Field of Search** ..... D8/349, 354, 356,  
D8/363, 373, 380; 248/200, 218.4, 227.3,  
300; 256/59, 65.01, 65.02, 65.03, 65.04,  
65.06, 65.07, 66; 403/187, 192, 230, 260,  
262

(56) **References Cited**

**U.S. PATENT DOCUMENTS**

- 949,075 A \* 2/1910 Hulett ..... 256/65.06
- 2,528,358 A \* 10/1950 Grass ..... 256/65.06
- 4,114,861 A \* 9/1978 Long ..... D8/380
- 4,265,423 A 5/1981 Vecchiarelli
- 4,280,686 A 7/1981 Wack
- 4,616,950 A 10/1986 Morris
- 4,825,621 A 5/1989 Jensen
- D319,573 S \* 9/1991 Rogers ..... D8/380
- 5,186,571 A 2/1993 Hentzschel
- 5,190,268 A 3/1993 Espinueva
- 5,238,321 A 8/1993 Jarjoura
- 5,547,169 A \* 8/1996 Russell ..... 256/67

- 5,603,580 A 2/1997 Leek et al.
- D378,986 S \* 4/1997 Darula ..... D8/354
- 5,795,503 A 8/1998 Krake
- D409,078 S 5/1999 Bolt
- 5,961,242 A 10/1999 Leone
- 6,053,481 A 4/2000 Scheide
- 6,471,192 B1 \* 10/2002 Erwin ..... 403/189

\* cited by examiner

*Primary Examiner*—Doris V. Coles  
*Assistant Examiner*—Elizabeth A. Albert  
(74) *Attorney, Agent, or Firm*—Phillip E. Walker

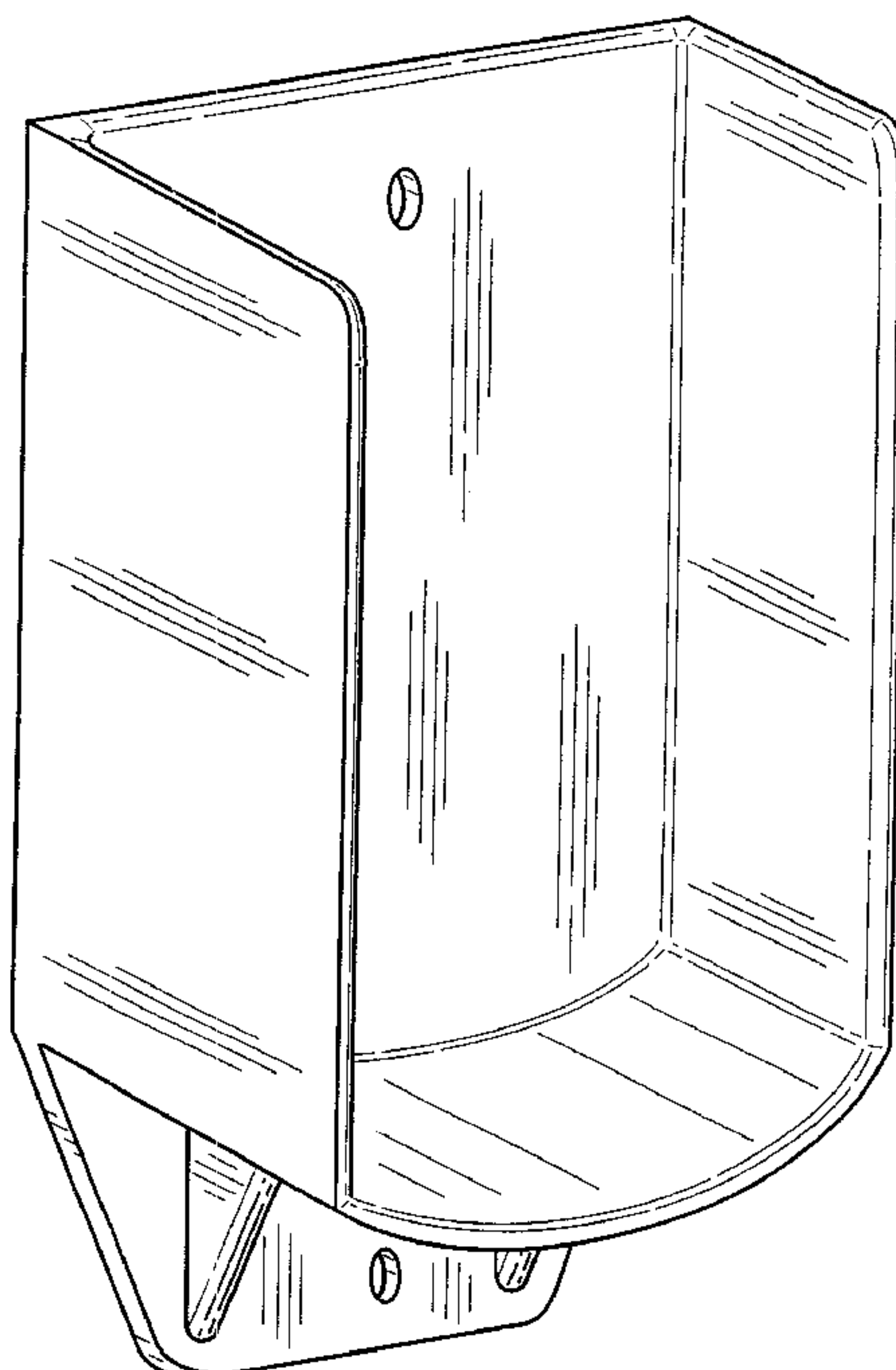
(57) **CLAIM**

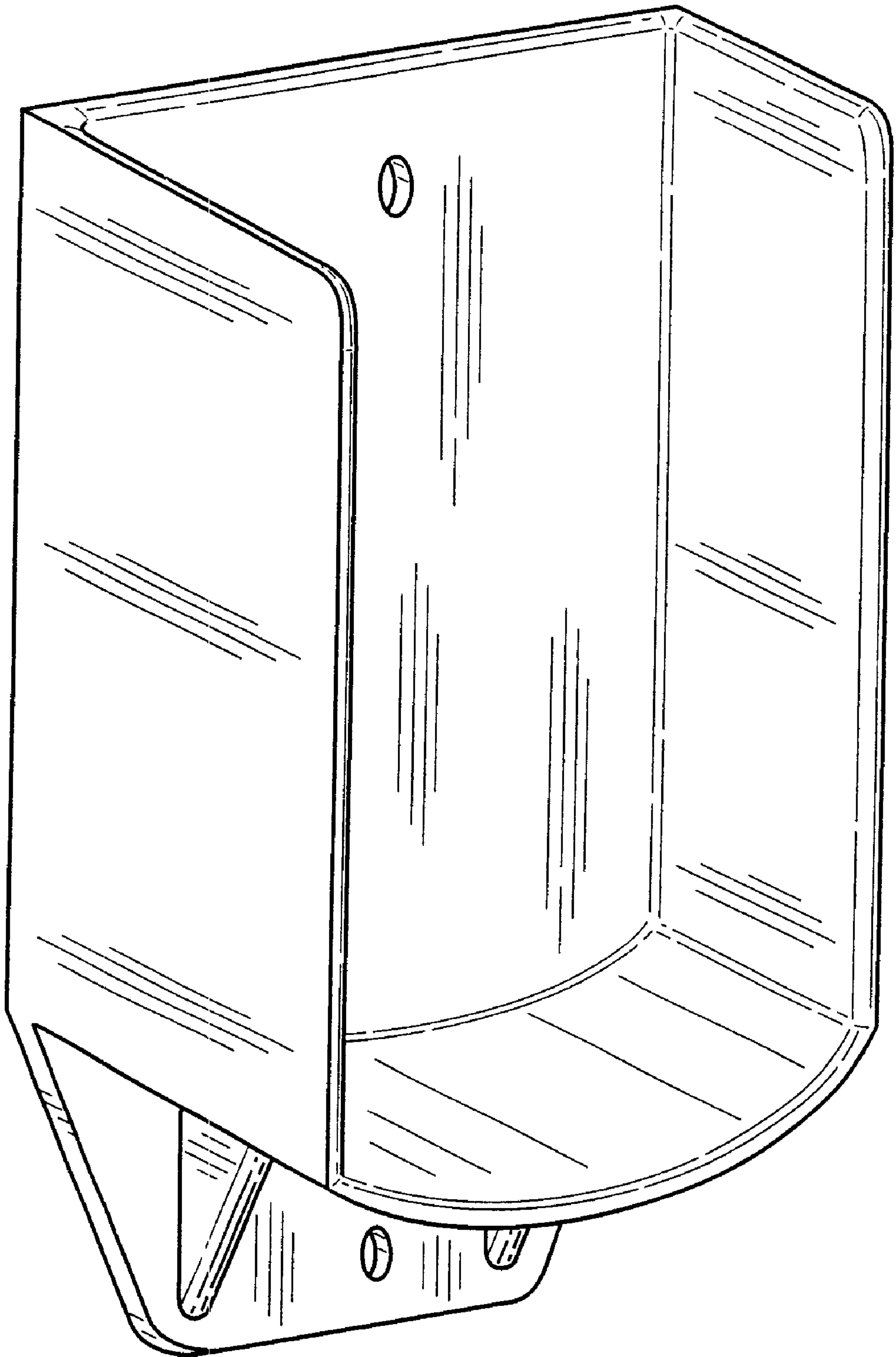
What is claimed is the ornamental design for a rail and fence bracket apparatus, as shown and described.

**DESCRIPTION**

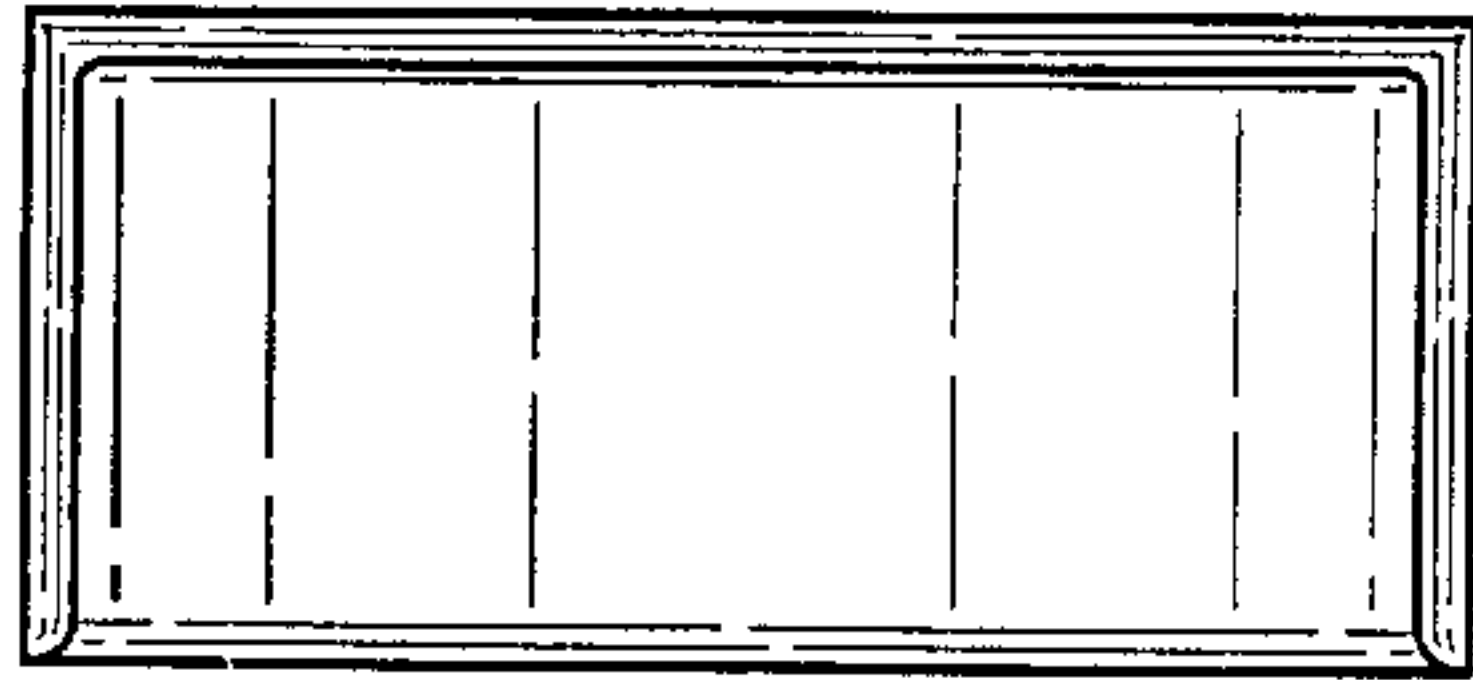
FIG. 1 is a perspective front view of the rail and fence bracket apparatus showing my new design;  
 FIG. 2 is a front elevation view of the rail and fence bracket apparatus shown on a reduced scale;  
 FIG. 3 is a left side elevation view of the rail and fence bracket apparatus shown on a reduced scale;  
 FIG. 4 is a back elevation view of the rail and fence bracket apparatus shown on a reduced scale;  
 FIG. 5 is a right side elevation view of the rail and fence bracket apparatus shown on a reduced scale;  
 FIG. 6 is a top elevation view of the rail and fence bracket apparatus shown on a reduced scale;  
 FIG. 7 is a bottom elevation view of the rail and fence bracket apparatus shown on a reduced scale; and,  
 FIG. 8 is an alternate perspective front view of the rail and fence bracket apparatus shown on an enlarged scale.

**1 Claim, 3 Drawing Sheets**

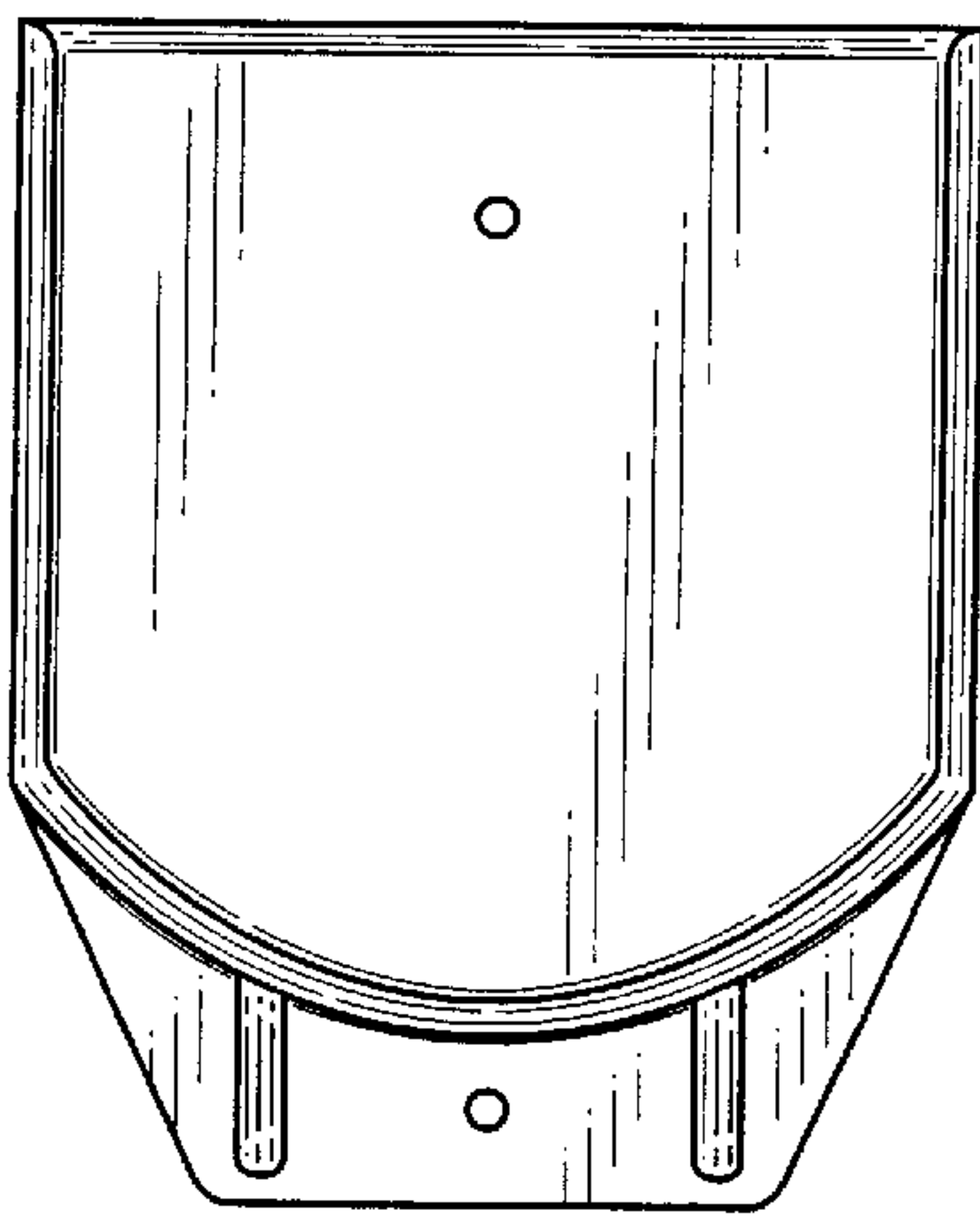




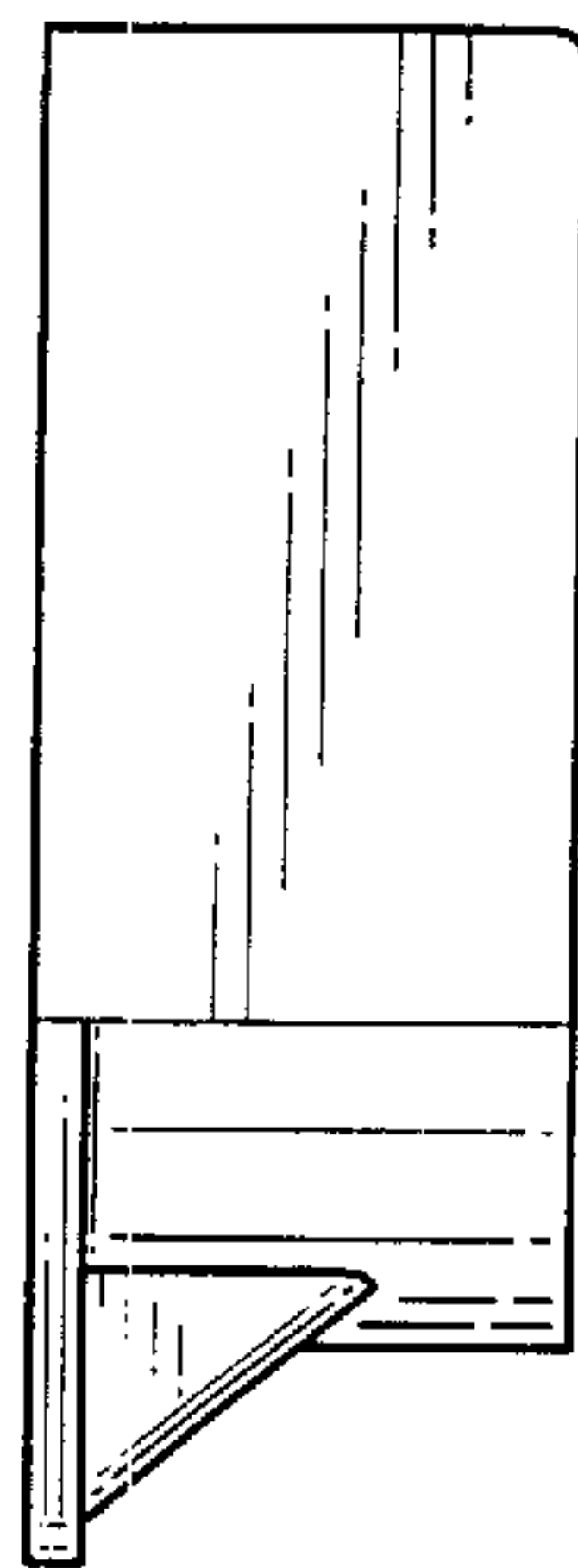
***FIG. 1***



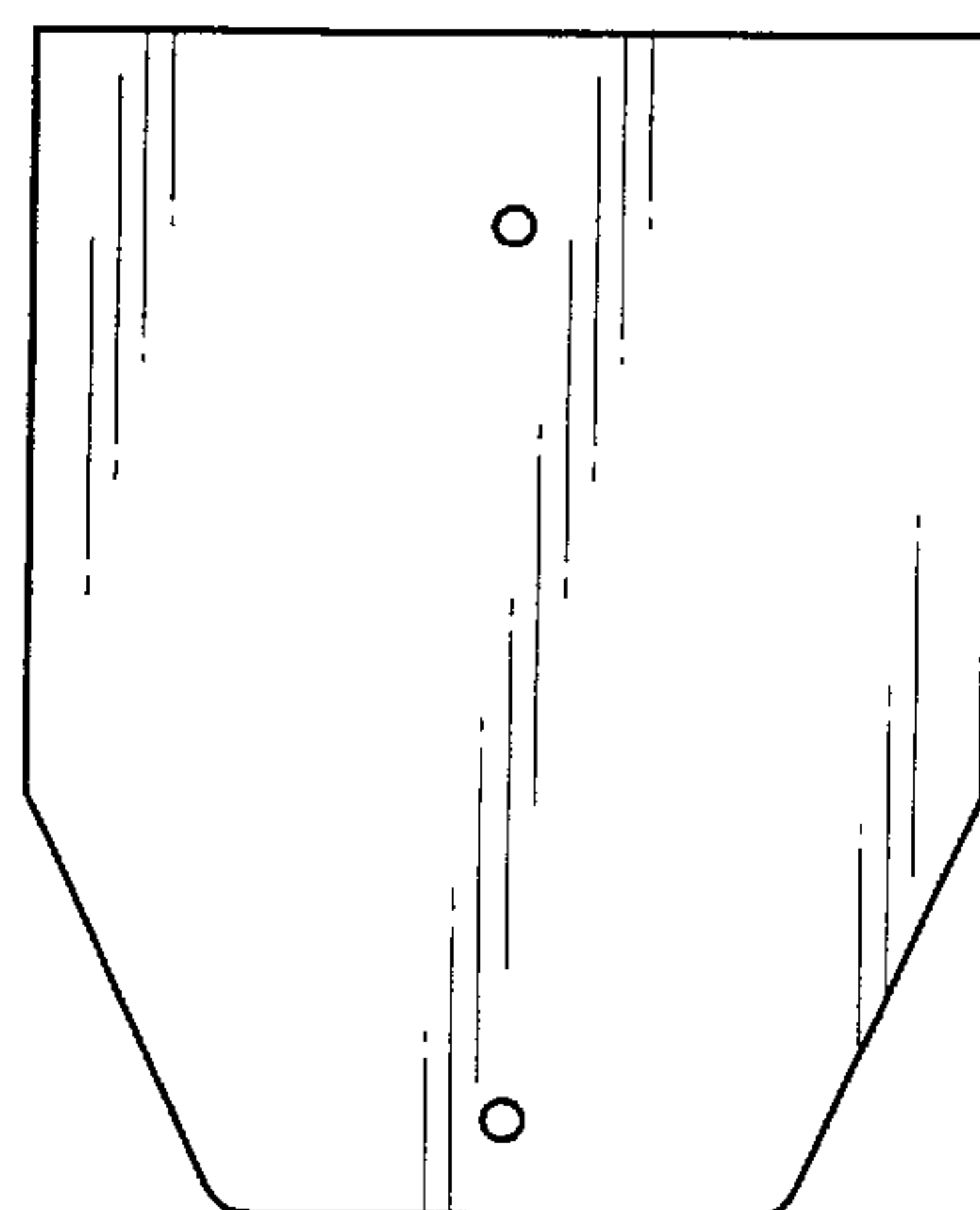
*FIG. 6*



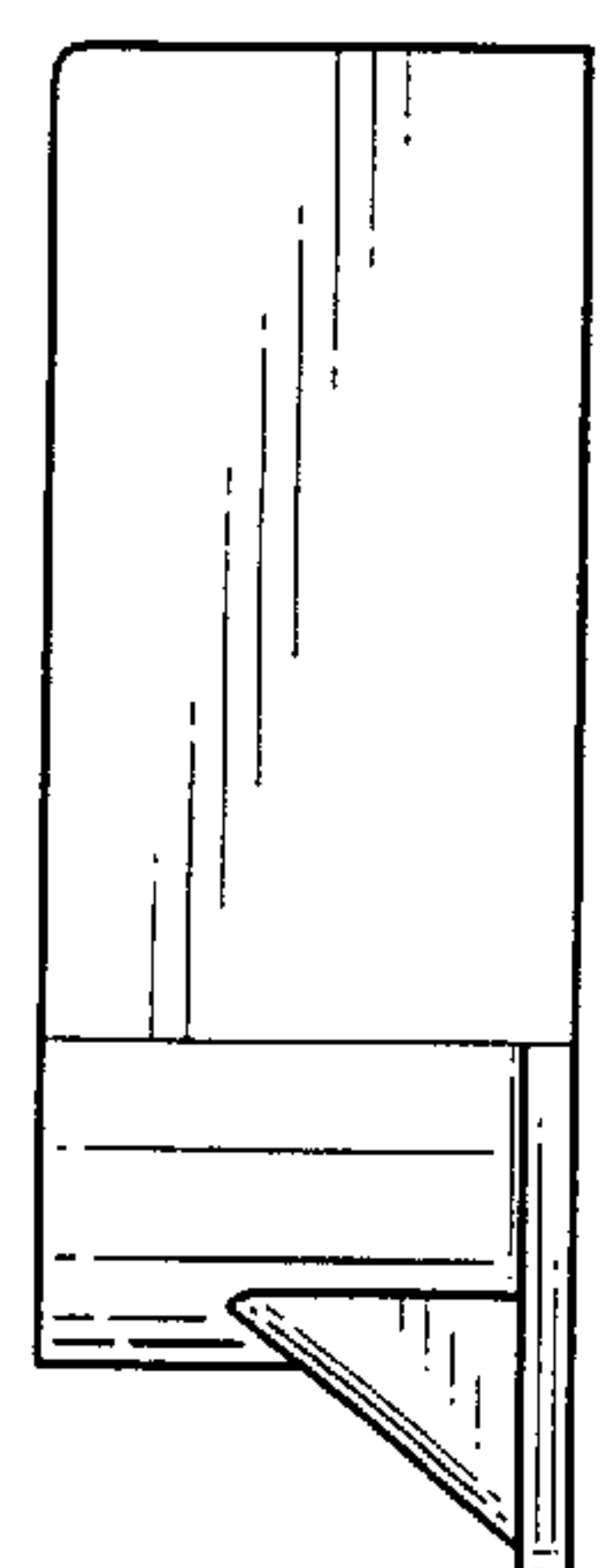
*FIG. 2*



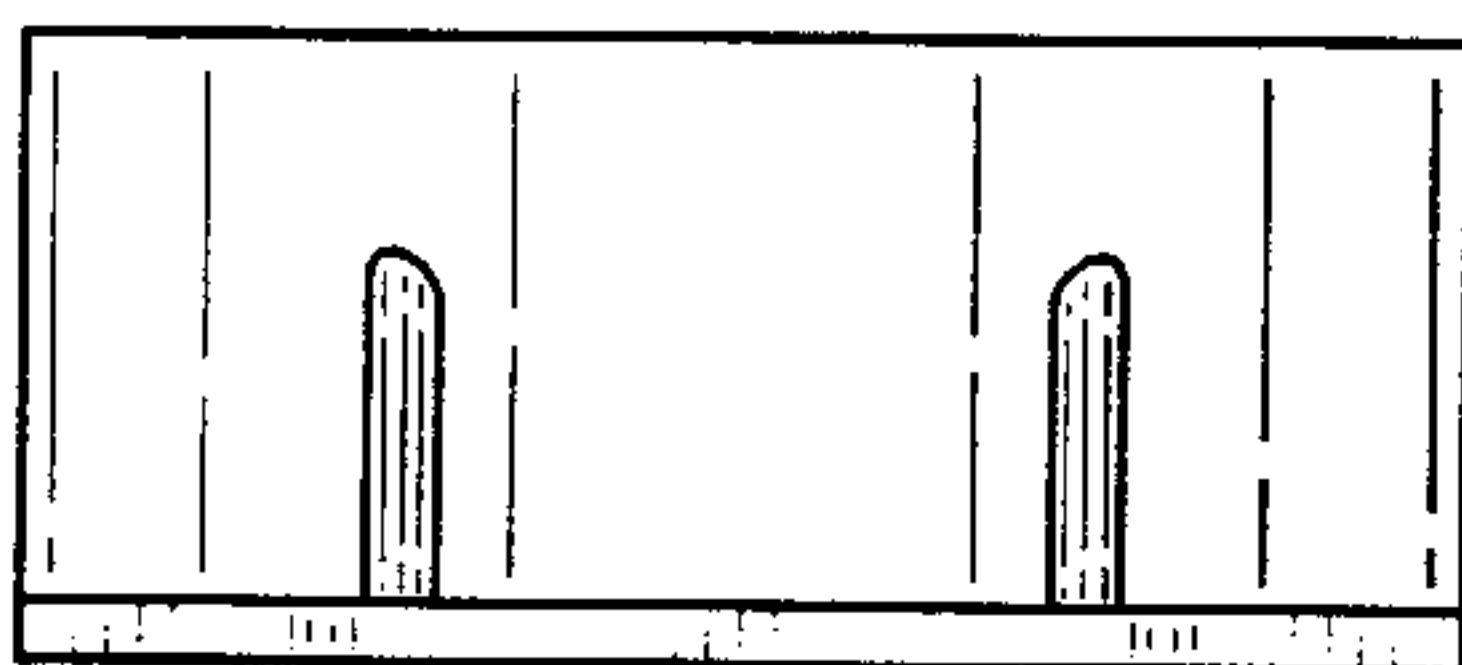
*FIG. 3*



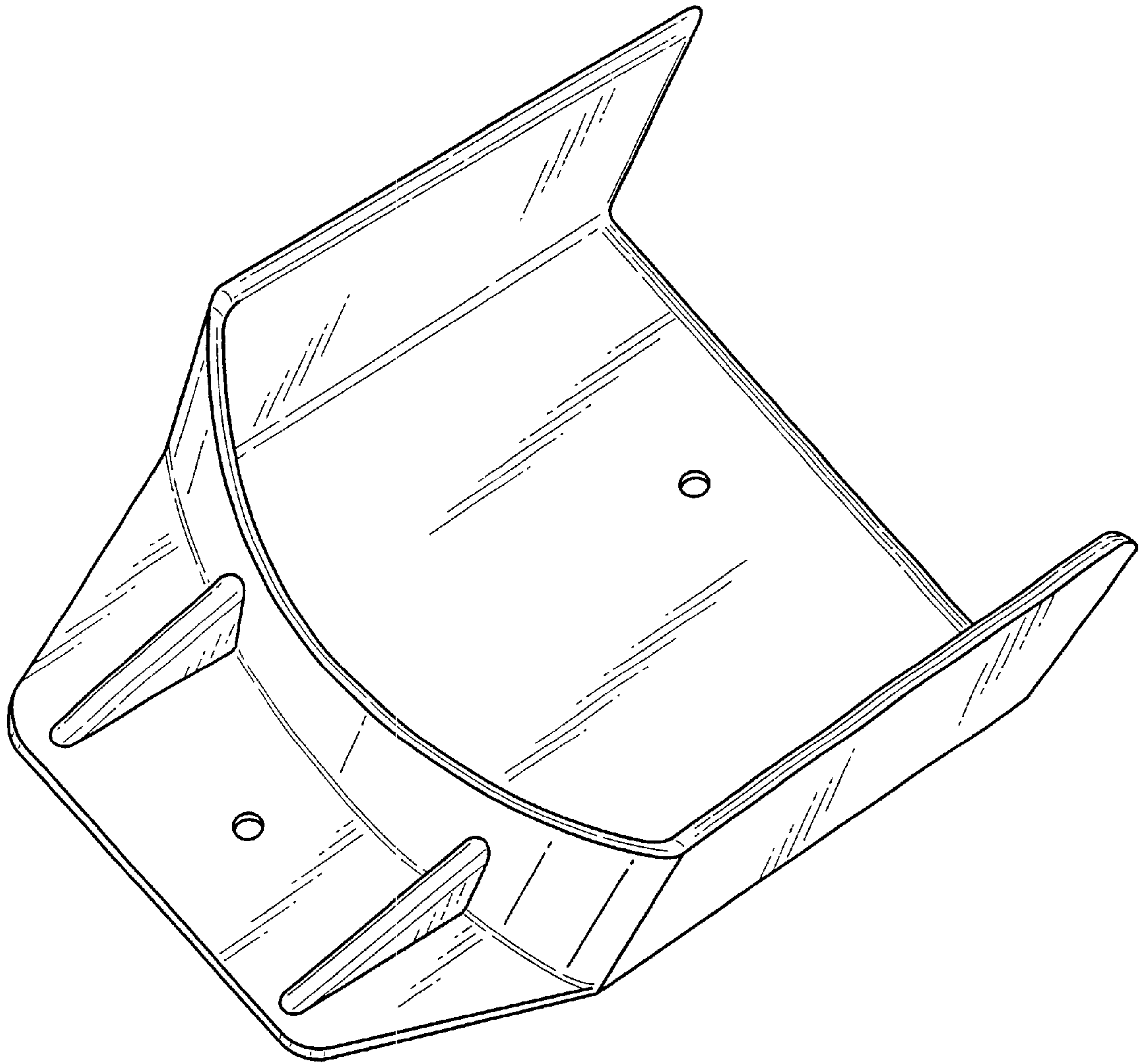
*FIG. 4*



*FIG. 5*



*FIG. 7*



*FIG. 8*