



US00D478598S

(12) **United States Design Patent**
Gozdinsky

(10) **Patent No.:** **US D478,598 S**

(45) **Date of Patent:** **** Aug. 19, 2003**

(54) **PROPELLER FOR ELECTRIC POWERED
OUTBOARD MOTOR**

(76) **Inventor:** **David W. Gozdinsky**, 3716 Sullivan
Rd., Rock Creek, OH (US) 44084

(**) **Term:** **14 Years**

(21) **Appl. No.:** **29/172,233**

(22) **Filed:** **Dec. 9, 2002**

(51) **LOC (7) Cl.** **15-01**

(52) **U.S. Cl.** **D15/5**

(58) **Field of Search** D15/1-5; 416/158,
416/157 R, 223 R; 454/329; 440/49, 50

(56) **References Cited**

U.S. PATENT DOCUMENTS

5,851,131 A	*	12/1998	Bergeron	440/50
D428,616 S	*	7/2000	Iekura	D15/4
6,332,818 B1	*	12/2001	Duncan et al.	440/50 X
6,340,290 B1	*	1/2002	Schott et al.	416/157 R
D463,448 S	*	9/2002	Osumi et al.	D15/4
D473,567 S	*	4/2003	Campbell	D15/5

* cited by examiner

Primary Examiner—Melody N. Brown

(74) *Attorney, Agent, or Firm*—Howard M. Cohn

(57) **CLAIM**

The ornamental design for a propeller for electric powered outboard motor, as shown and described.

DESCRIPTION

FIG. 1 is a top, left, front perspective view of a propeller for an electric powered outboard motor, shown with a hub in broken lines to secure the propeller onto a shaft (not shown). FIG. 2 is a top, left, front perspective view of a propeller for electric powered outboard motor;

FIG. 3 is a top plan view of a propeller for electric powered outboard motor, shown with structural members in broken lines to secure the propeller onto a shaft (not shown);

FIG. 4 is a bottom plan view of a propeller for electric powered outboard motor, shown with structural members in broken lines to secure the propeller onto a shaft (not shown);

FIG. 5 is a front elevational view of a propeller for electric powered outboard motor;

FIG. 6 is a left side elevational view of a propeller for electric powered outboard motor;

FIG. 7 is a right side elevational view of a propeller for electric powered outboard motor; and,

FIG. 8 is a rear elevational view of a propeller for electric powered outboard motor.

The structure members shown in broken lines in FIGS. 1 and 4 are for illustrative purposes only and form no part of the claimed design.

1 Claim, 4 Drawing Sheets

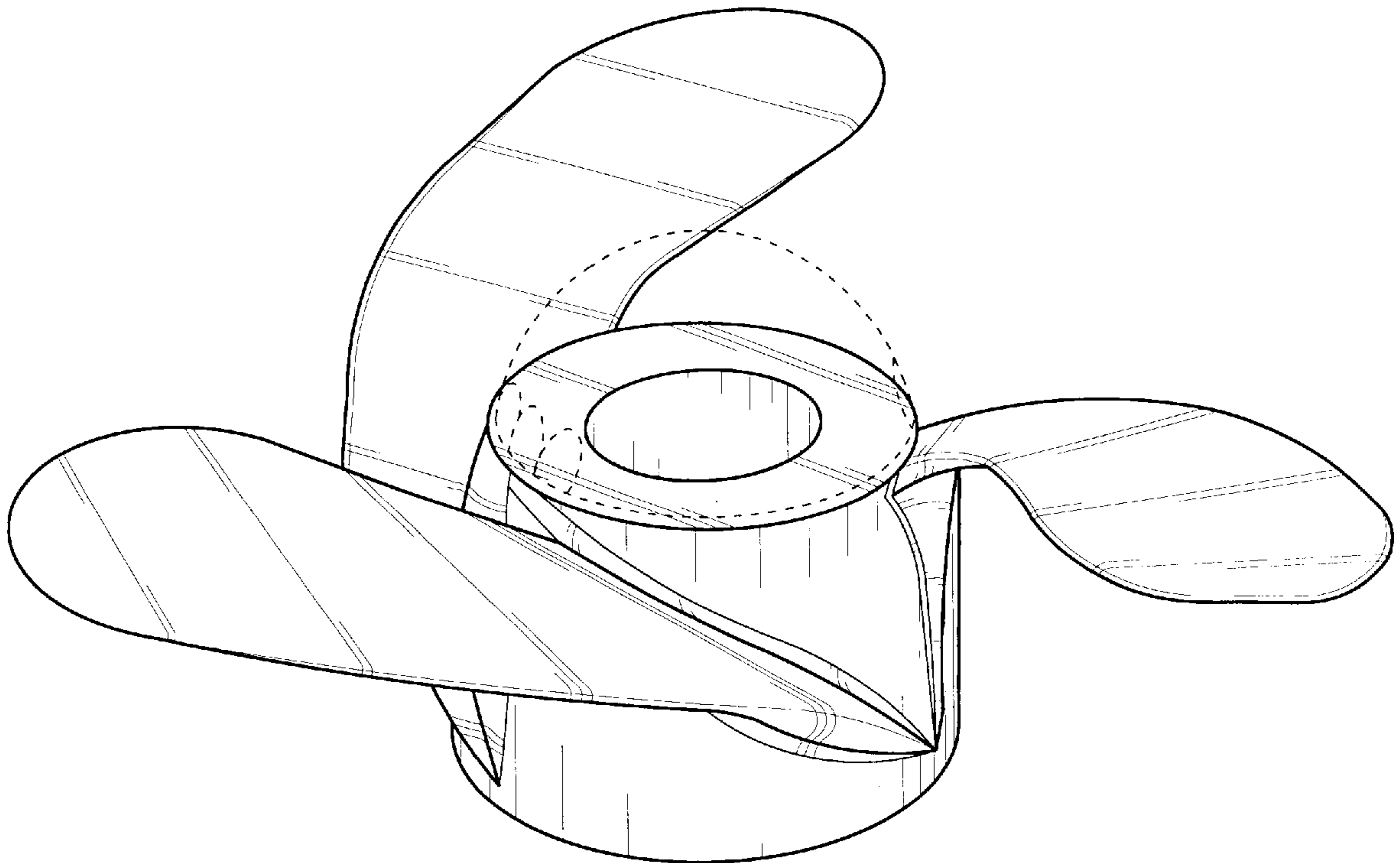

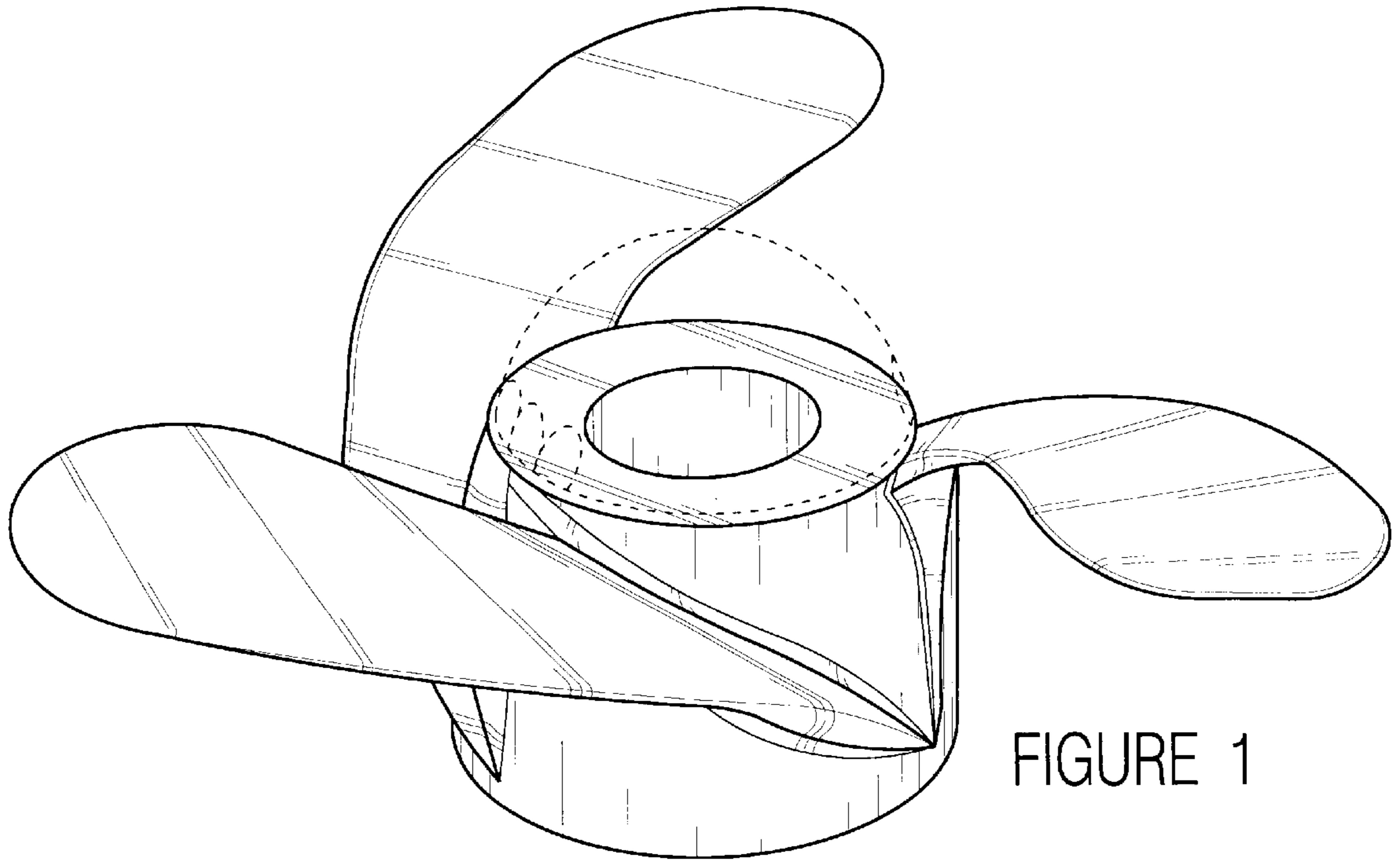

FIGURE 1

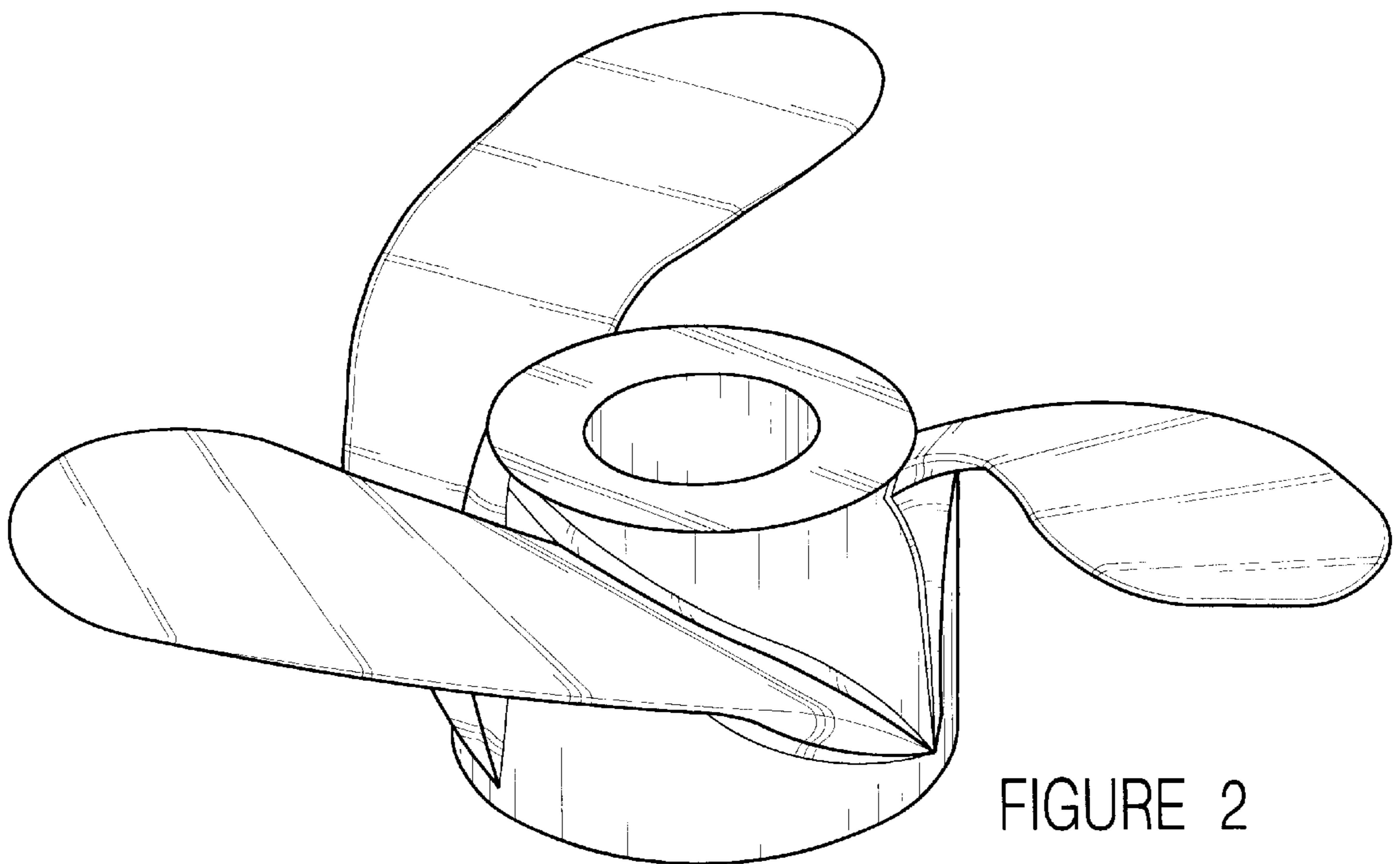

FIGURE 2

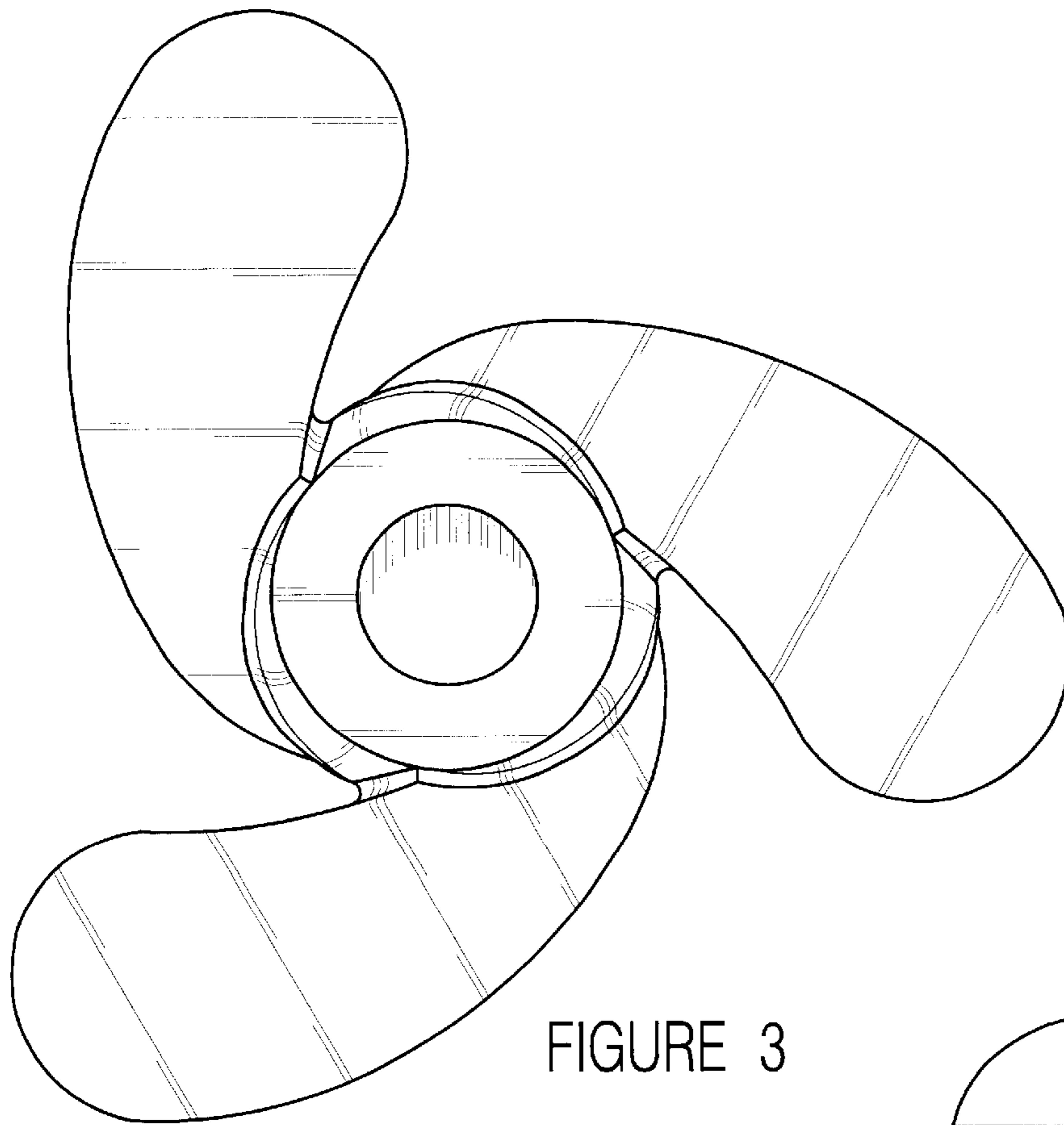

FIGURE 3

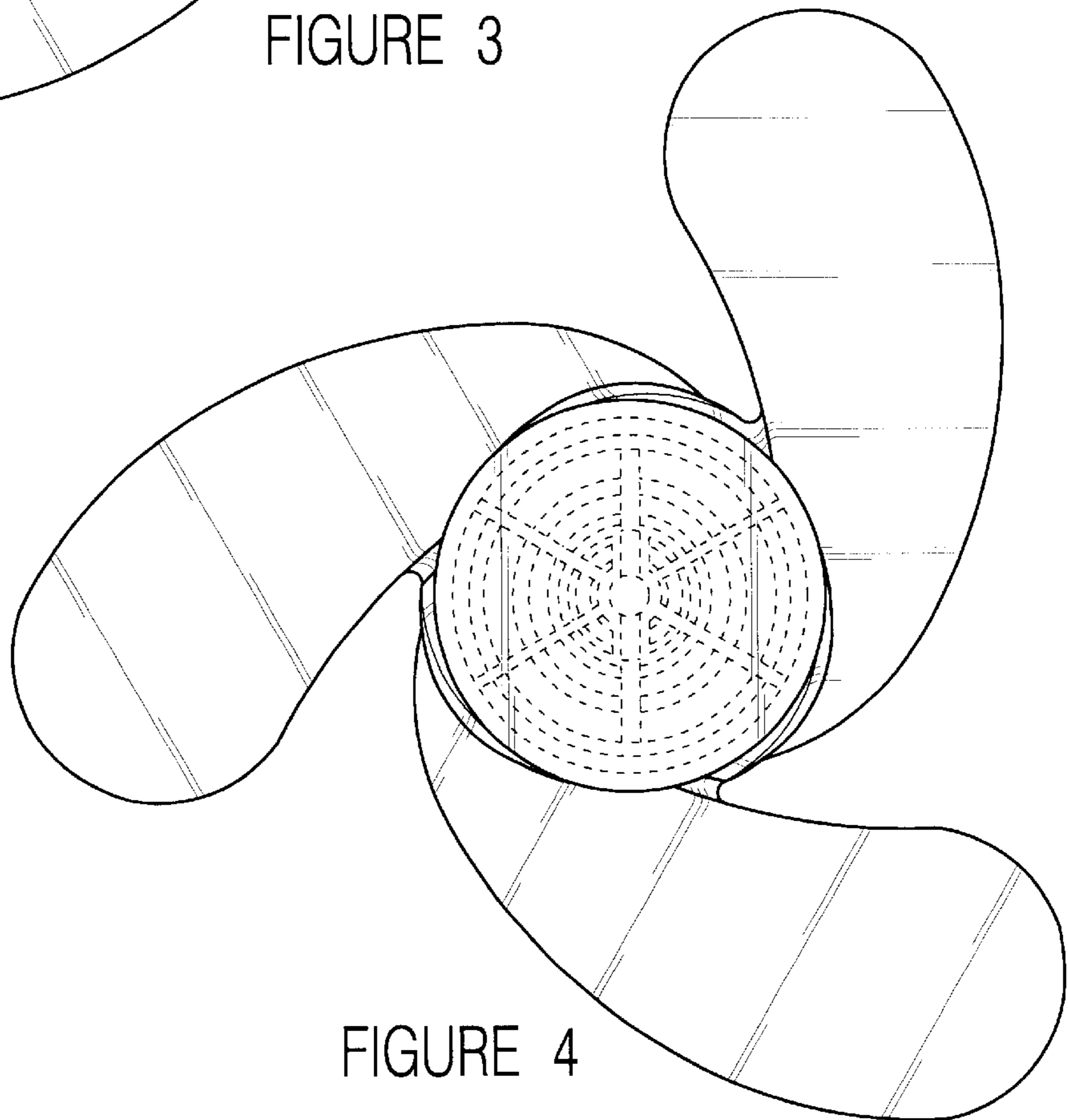

FIGURE 4

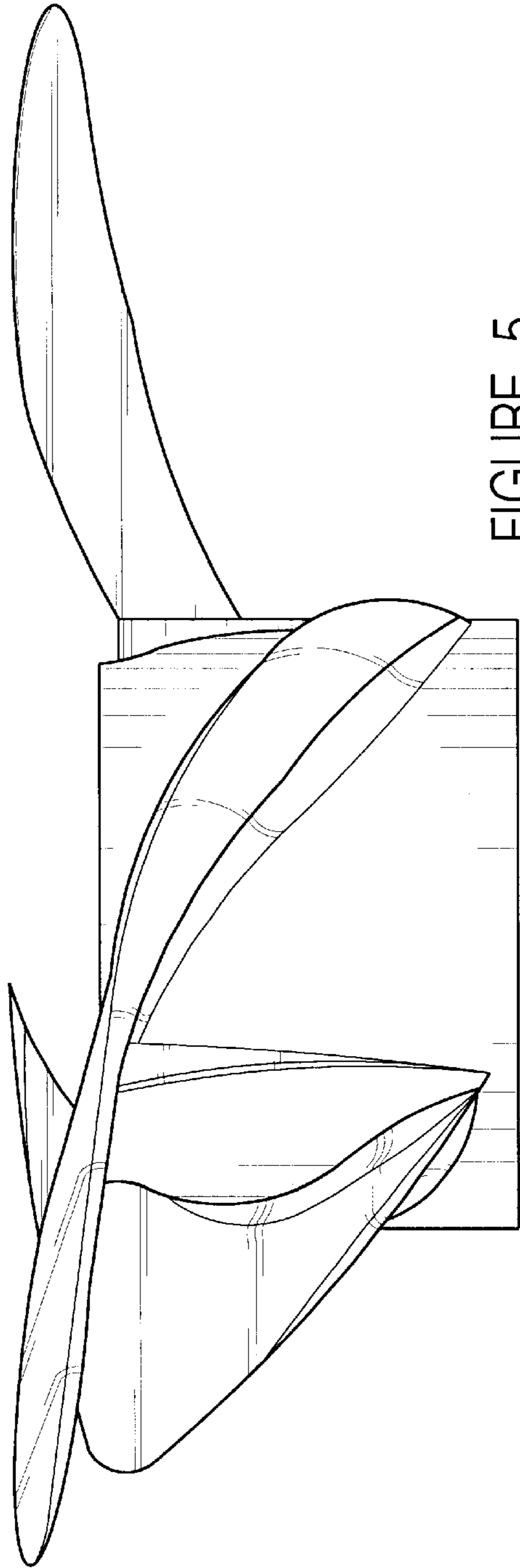

FIGURE 5

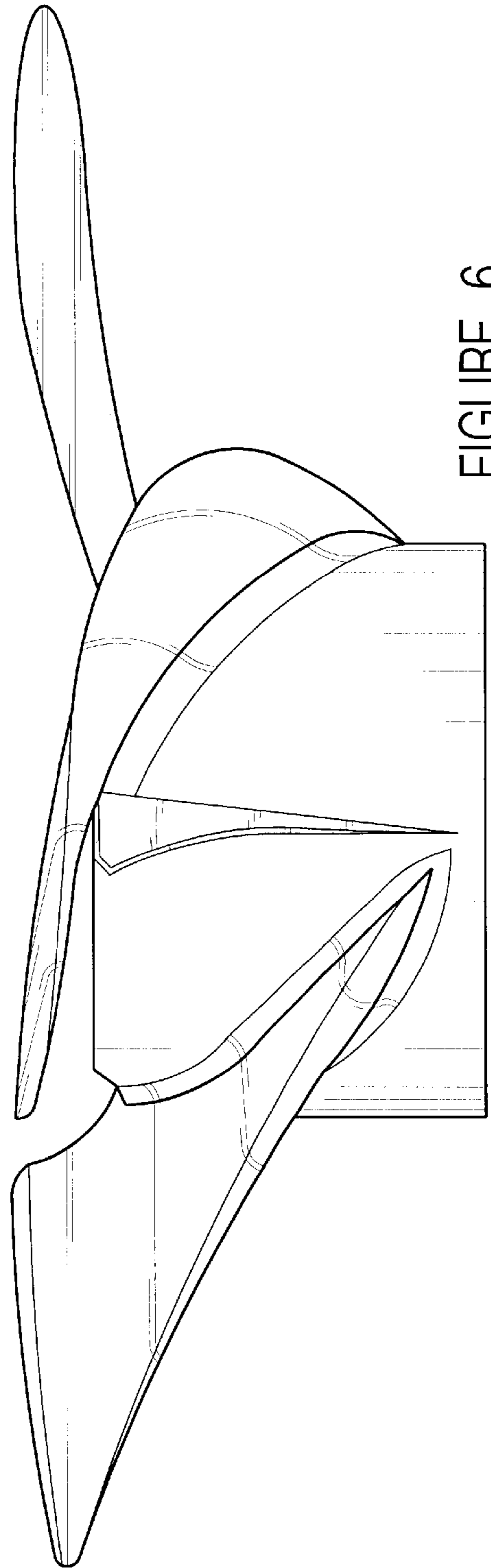

FIGURE 6

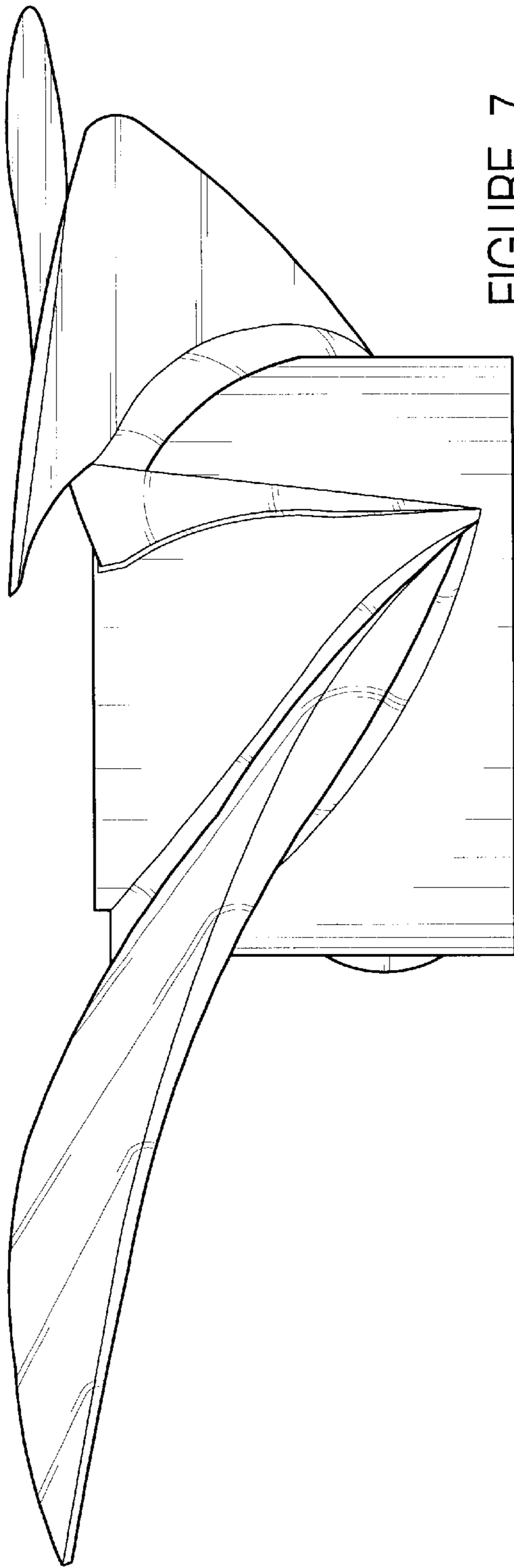

FIGURE 7

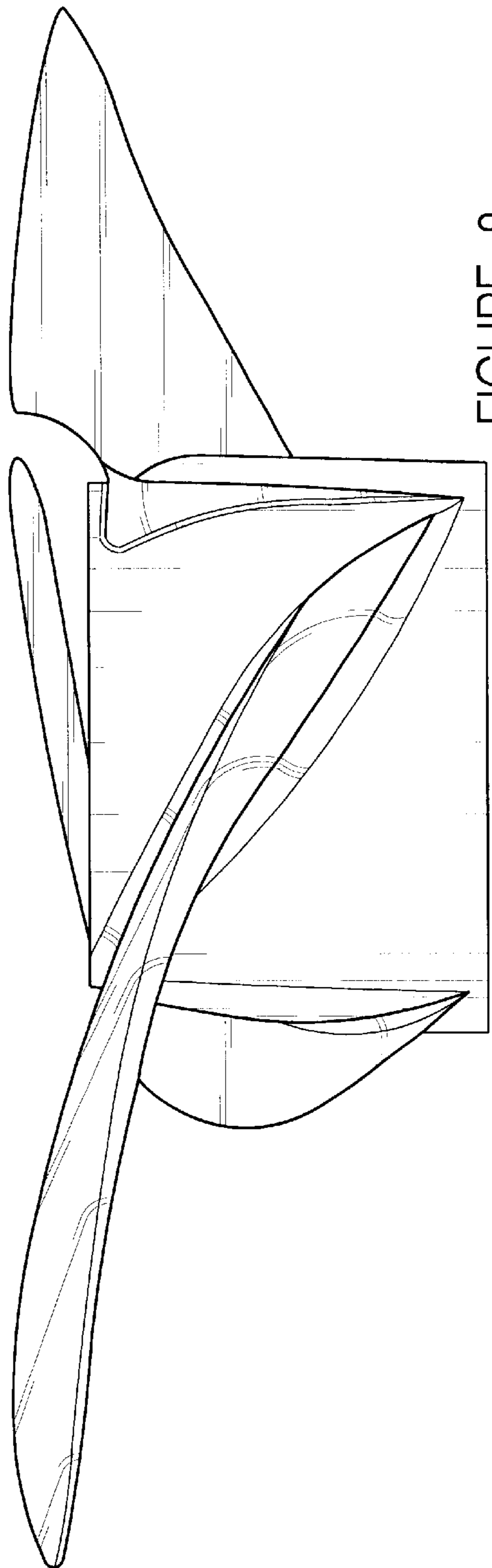

FIGURE 8