



US00D478545S

(12) **United States Design Patent**
Maeda et al.

(10) **Patent No.:** **US D478,545 S**

(45) **Date of Patent:** **** Aug. 19, 2003**

(54) **REAR BUMPER FOR PERSONAL WATERCRAFT**

(75) Inventors: **Kiyoaki Maeda**, Hyogo (JP); **Kanji Kiyohara**, Hyogo (JP); **Takeru Ohshima**, Hyogo (JP); **Yukio Asakura**, Hyogo (JP)

(73) Assignee: **Kawasaki Jukogyo Kabushiki Kaisha**, Hyogo (JP)

(**) Term: **14 Years**

(21) Appl. No.: **29/168,262**

(22) Filed: **Sep. 27, 2002**

(30) **Foreign Application Priority Data**

Mar. 29, 2002 (JP) 2002-008425

(51) **LOC (7) Cl.** **12-06**

(52) **U.S. Cl.** **D12/317**

(58) **Field of Search** **D12/317, 168;**
114/219, 343, 361

(56) **References Cited**

FOREIGN PATENT DOCUMENTS

EP 0429107 A1 * 5/1991
JP 352043287 A * 5/1977

OTHER PUBLICATIONS

Corner bumper. Product Sheet [online]. Bart's Water Sports, 2001 [retrieved on Feb. 13, 2003]. Retrieved from the Internet: <http://web.archive.org/web/20010405141139/www.bartswatersports.com/catalog.asp?C=165>.*

M & E Marine, 1998, Corner bumpers, located in middle of page, p. 50.*

* cited by examiner

Primary Examiner—Holly Baynham

(74) *Attorney, Agent, or Firm*—Marshall, Gerstein & Borun

(57) **CLAIM**

A rear bumper for personal watercraft, as shown and described.

DESCRIPTION

FIG. 1 is a perspective view of a rear bumper for a personal watercraft in accordance with the present invention;

FIG. 2 is a front view thereof;

FIG. 3 is a rear view thereof;

FIG. 4 is a right-side view thereof;

FIG. 5 is a left-side view thereof;

FIG. 6 is a top plain view thereof;

FIG. 7 is a bottom view thereof;

FIG. 8 is a cross sectional view taken through line 8—8 of FIG. 2;

FIG. 9 is a cross sectional view taken through line 9—9 of FIG. 2;

FIG. 10 is a cross sectional view taken through line 10—10 of FIG. 4;

FIG. 11 is a cross sectional view taken through line 11—11 of FIG. 6;

FIG. 12 is a cross sectional view taken through line 12—12 of FIG. 6;

FIG. 13 is a cross sectional view taken through line 13—13 of FIG. 6; and,

FIG. 14 is a referential view showing the article in use on a personal watercraft in accordance with the present invention.

The broken line showing of a personal watercraft is for illustrative purposes only and forms no part of the claimed design.

1 Claim, 8 Drawing Sheets

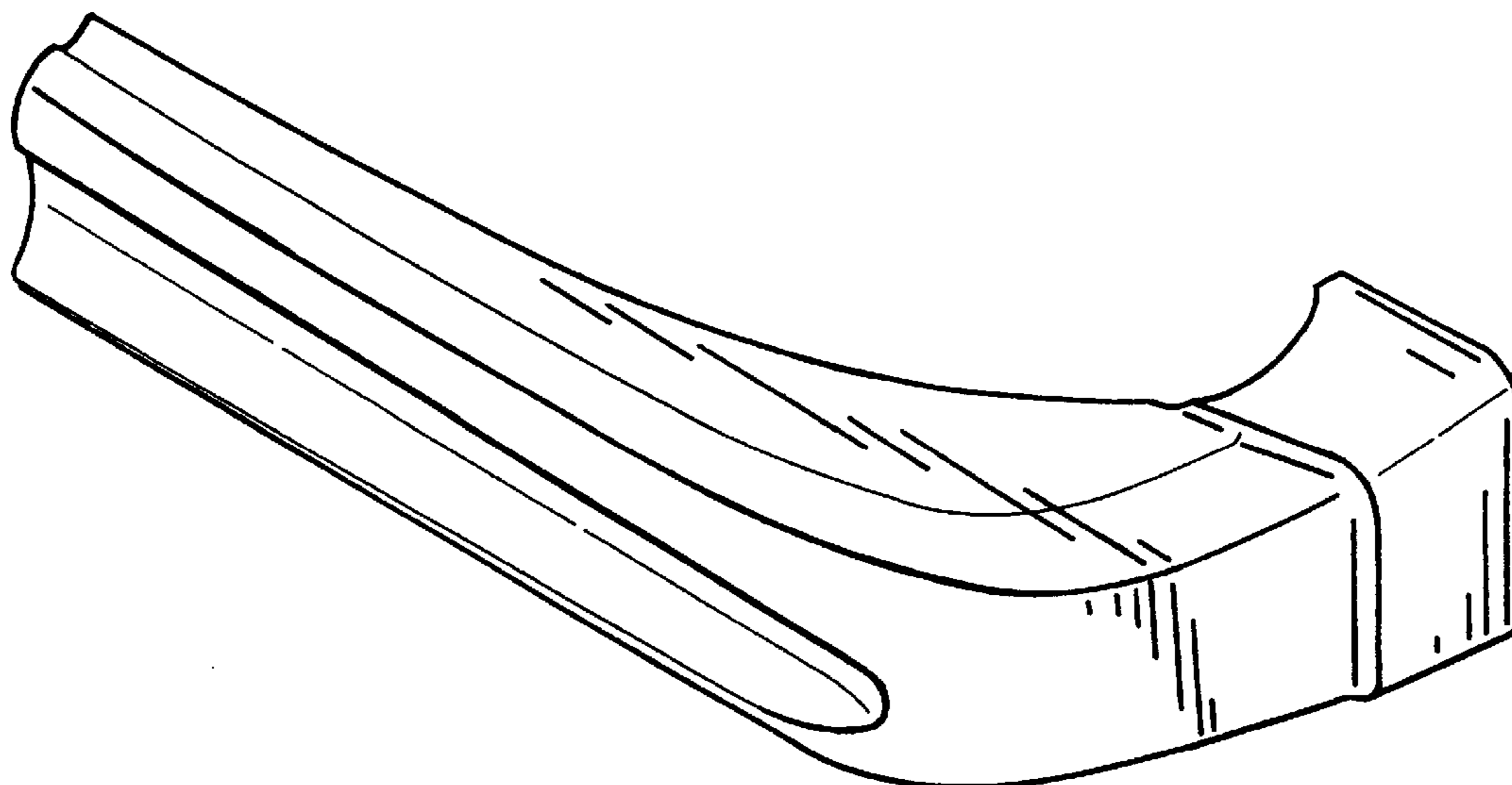

FIG. 1

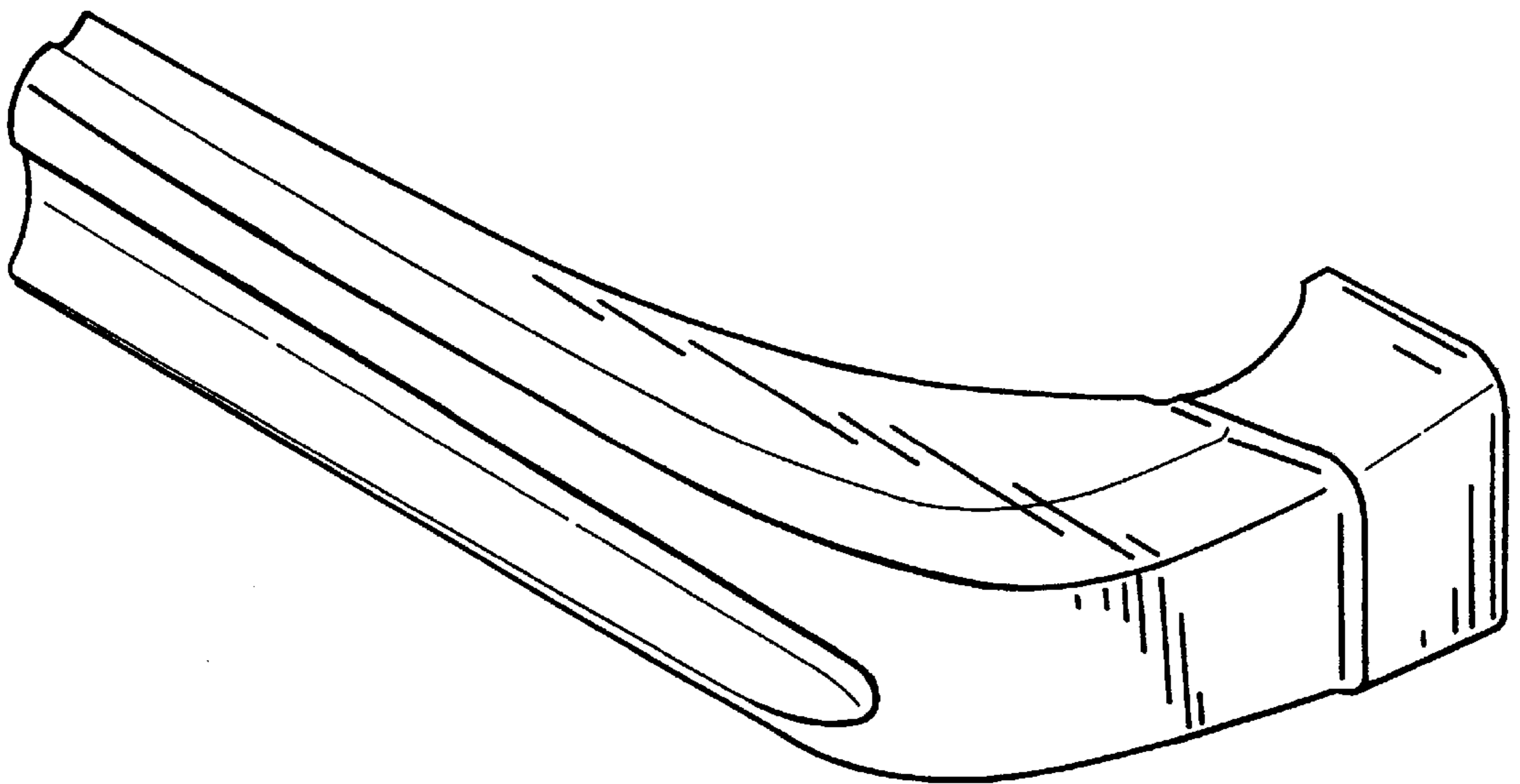

FIG. 2

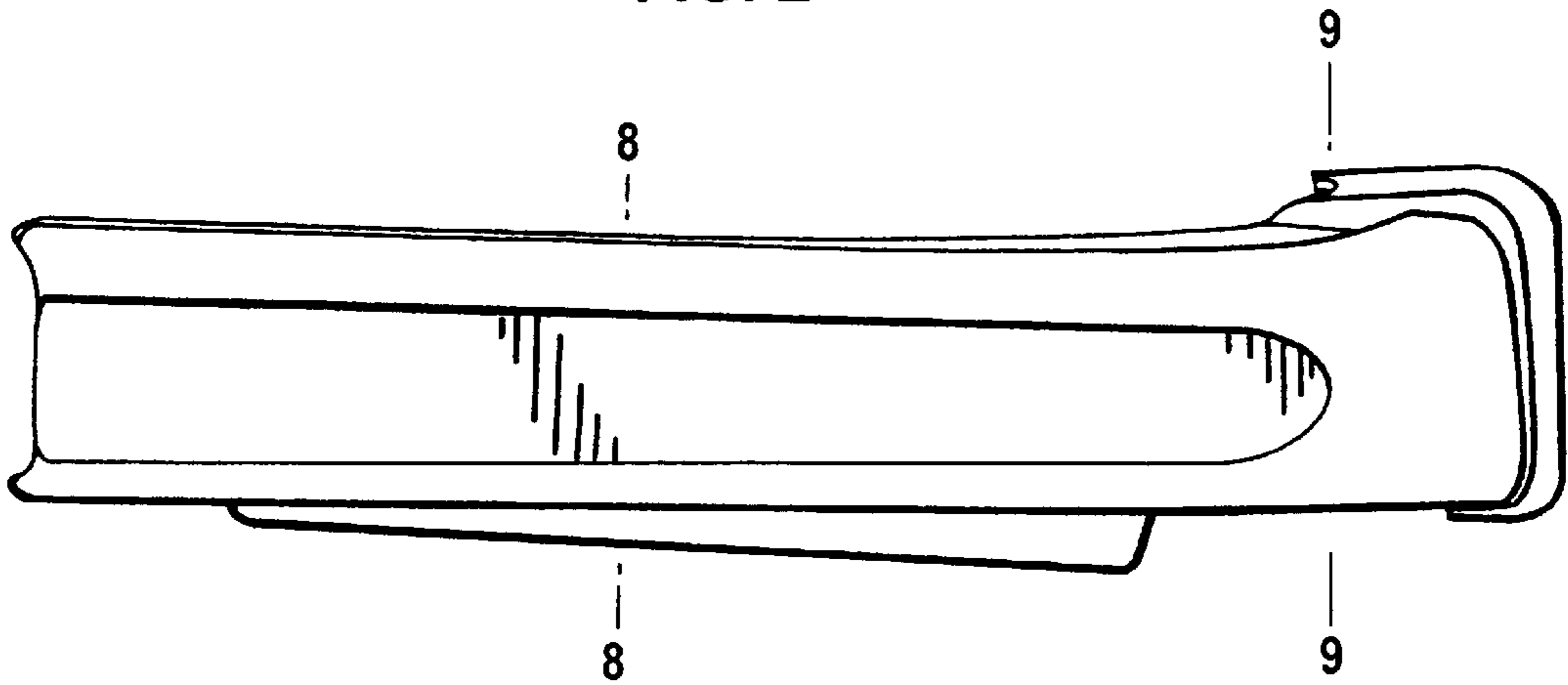

FIG. 3

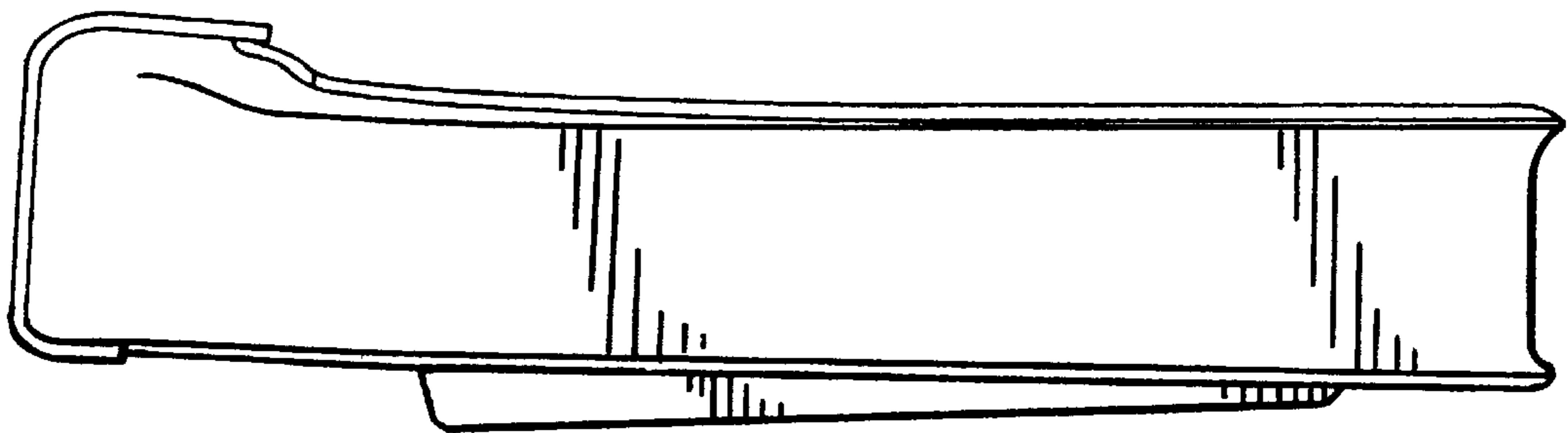

FIG. 4

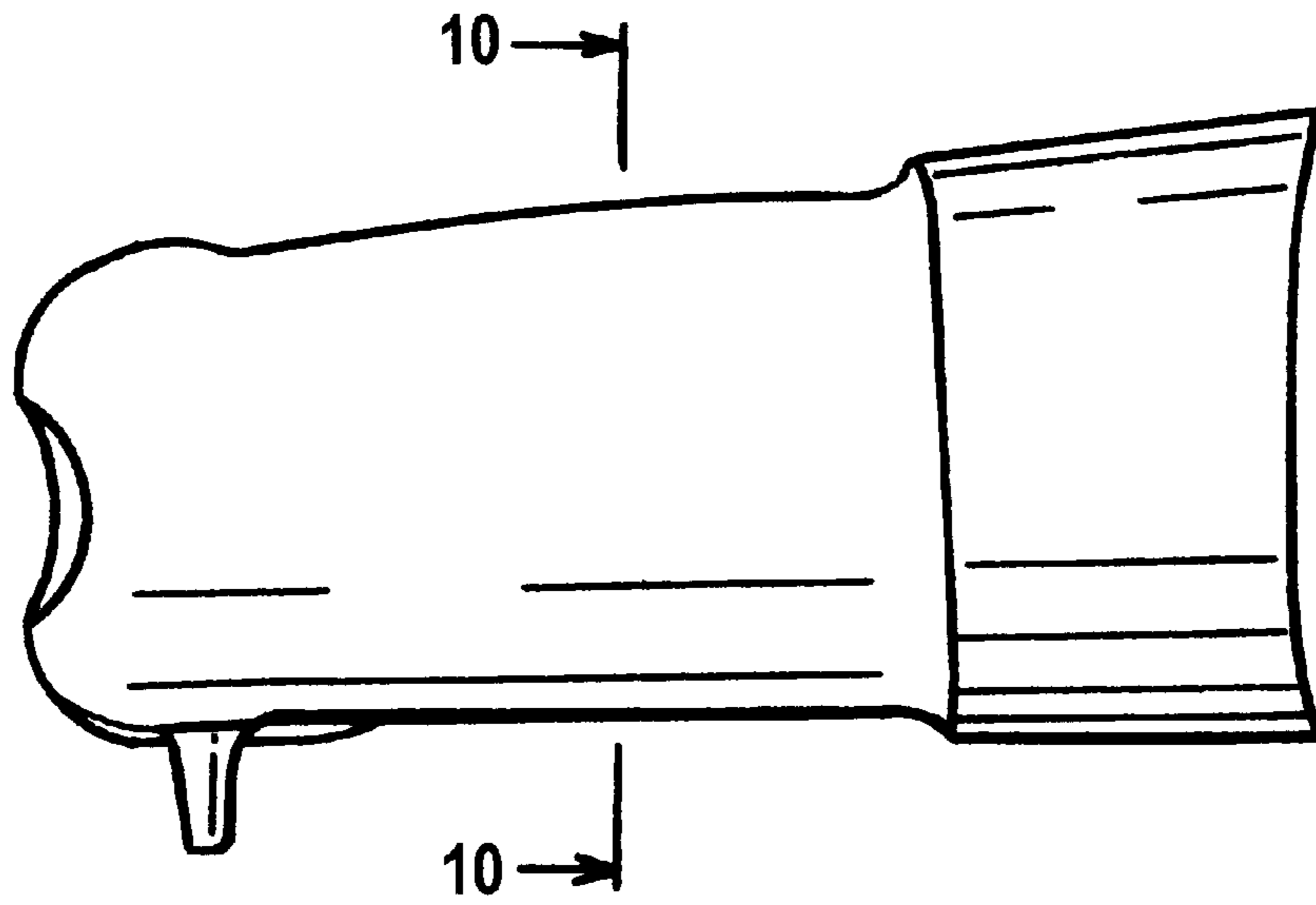

FIG. 5

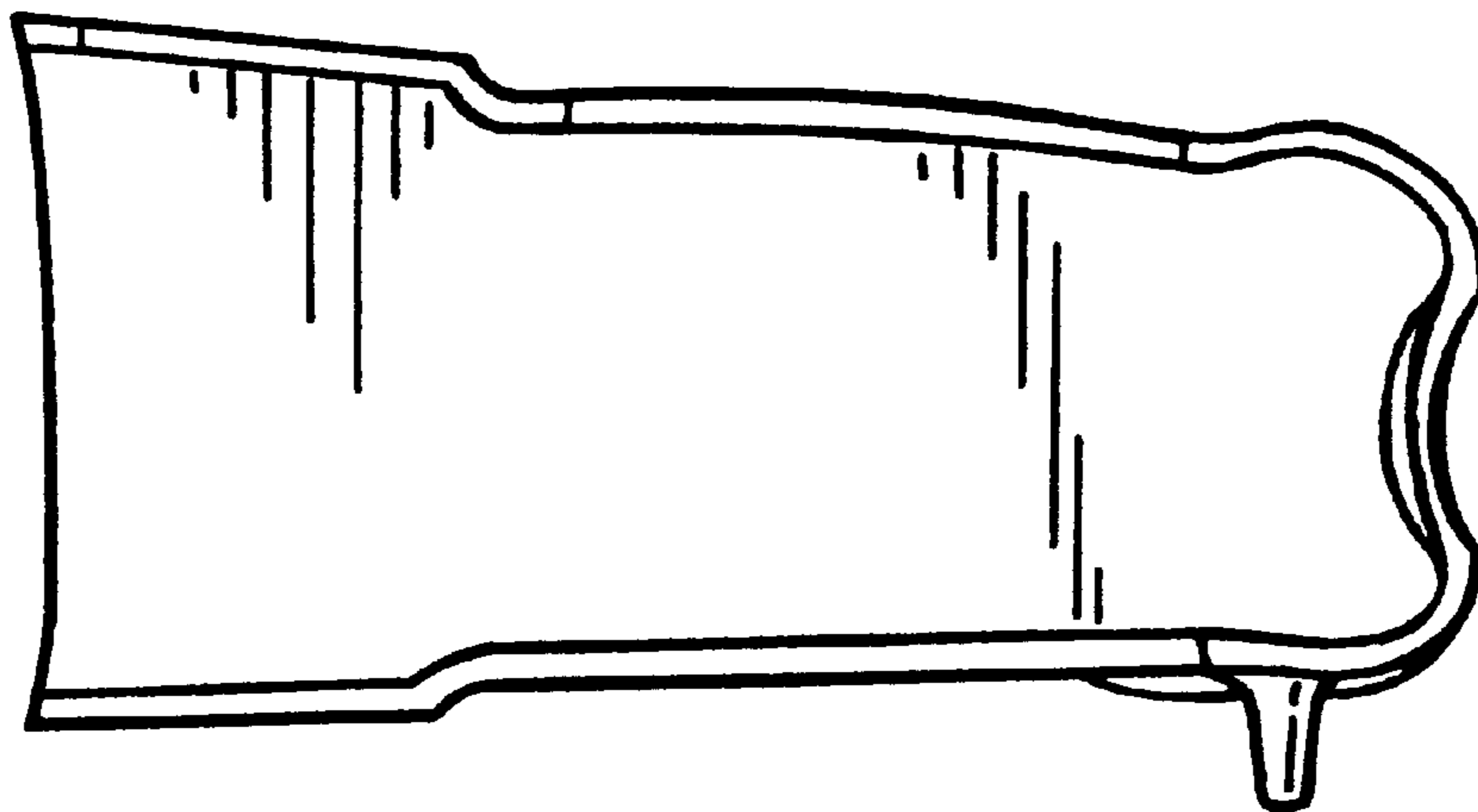

FIG. 6

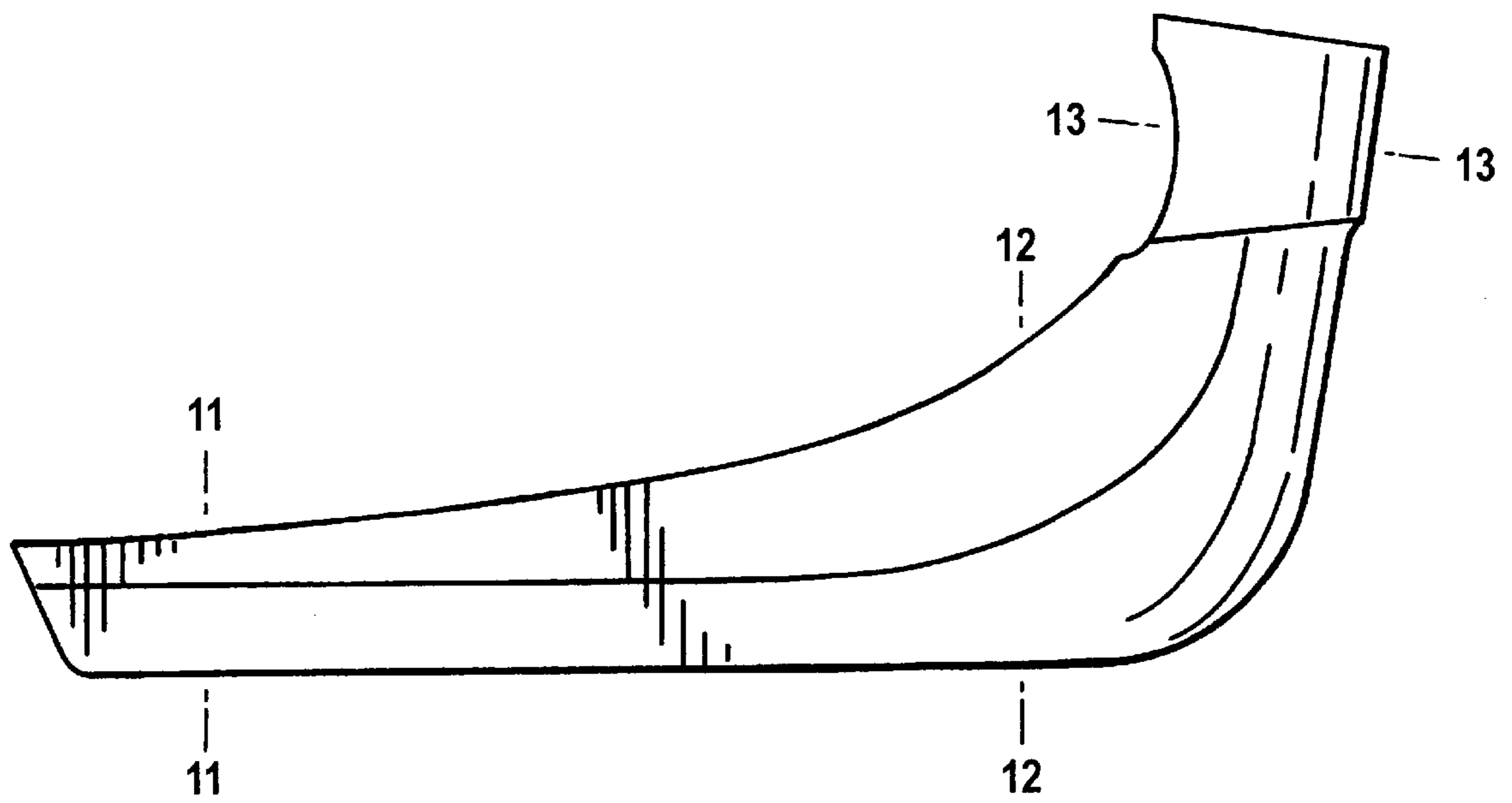

FIG. 7

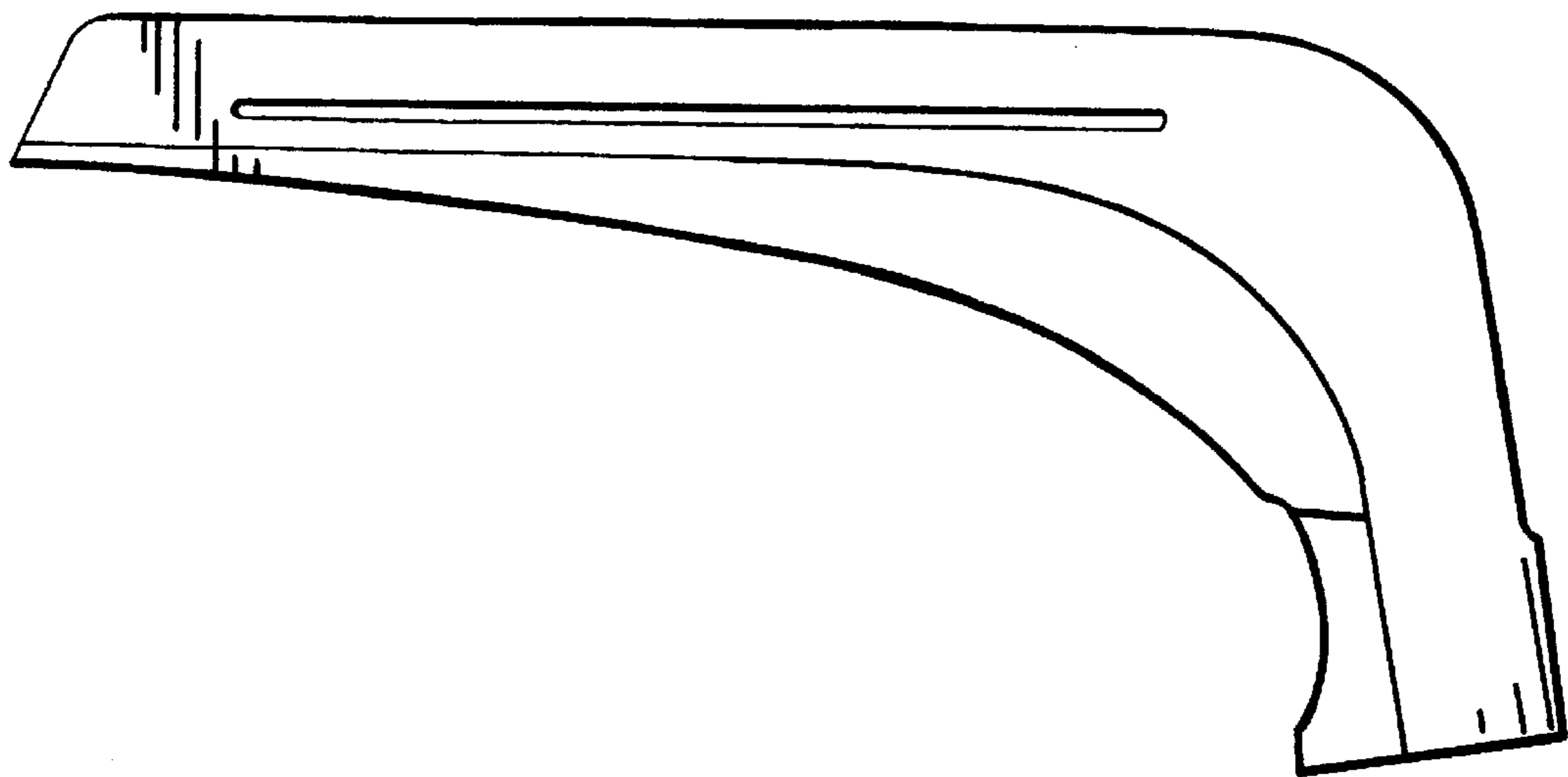

FIG. 8

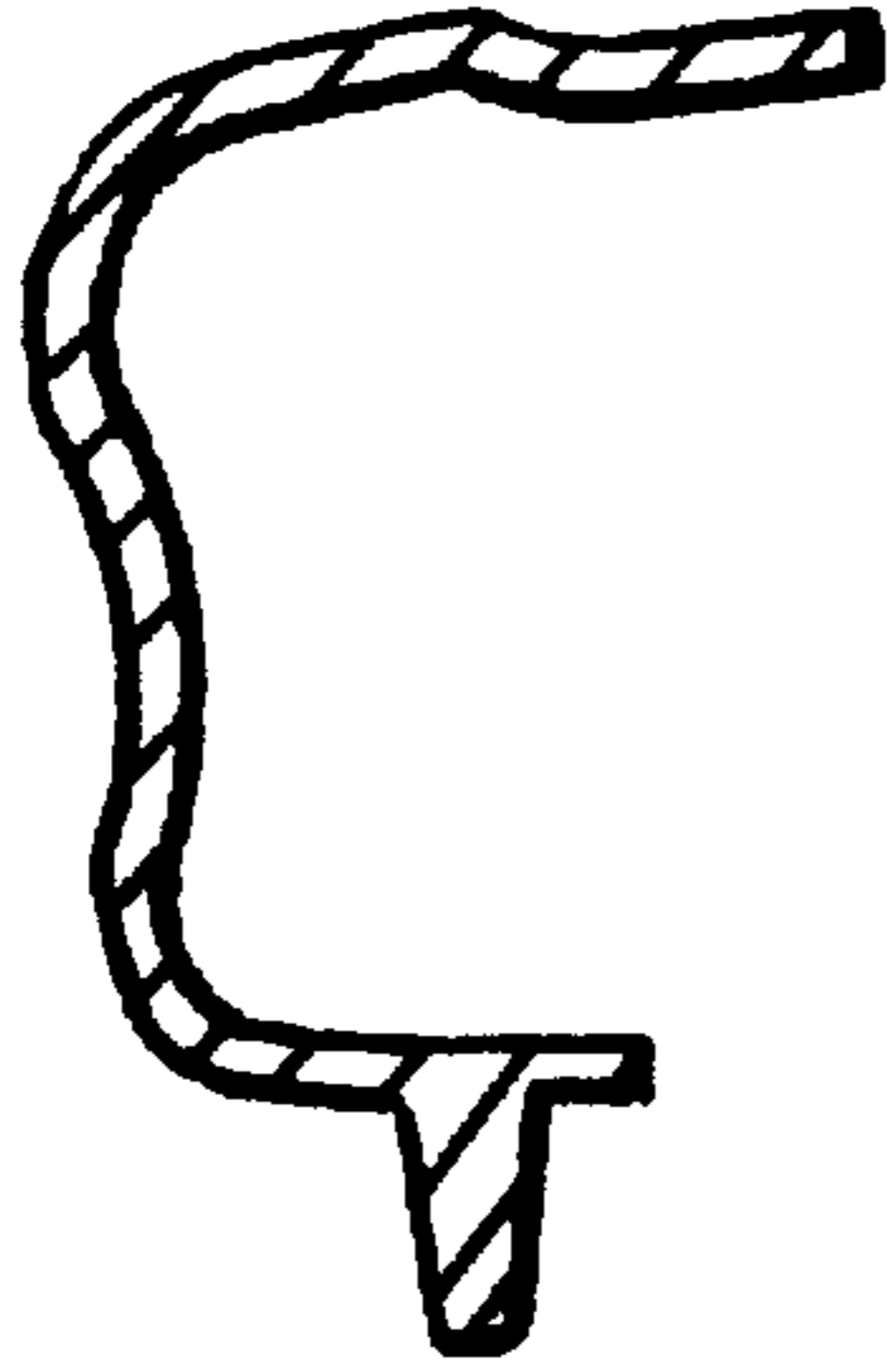

FIG. 9

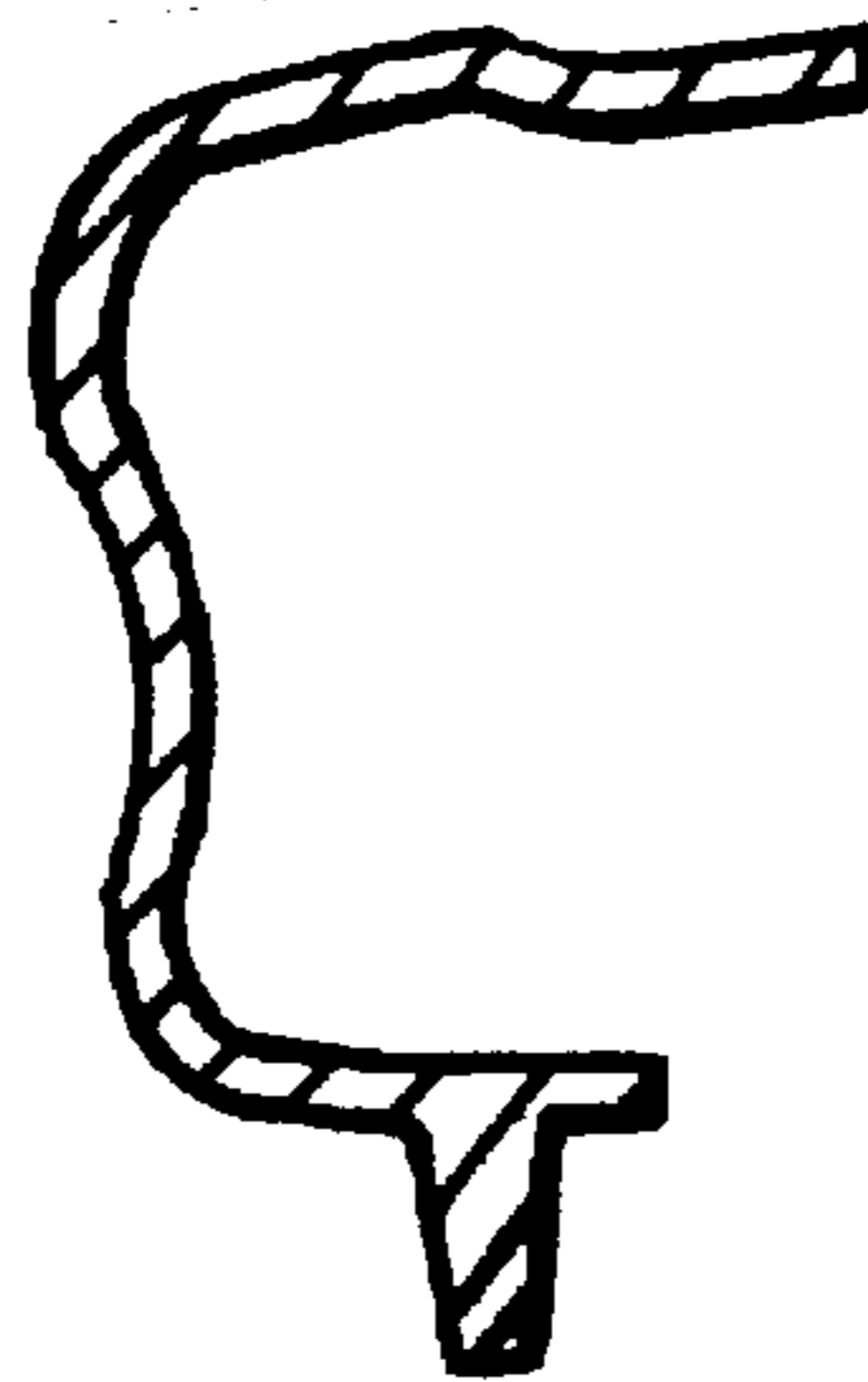

FIG. 10

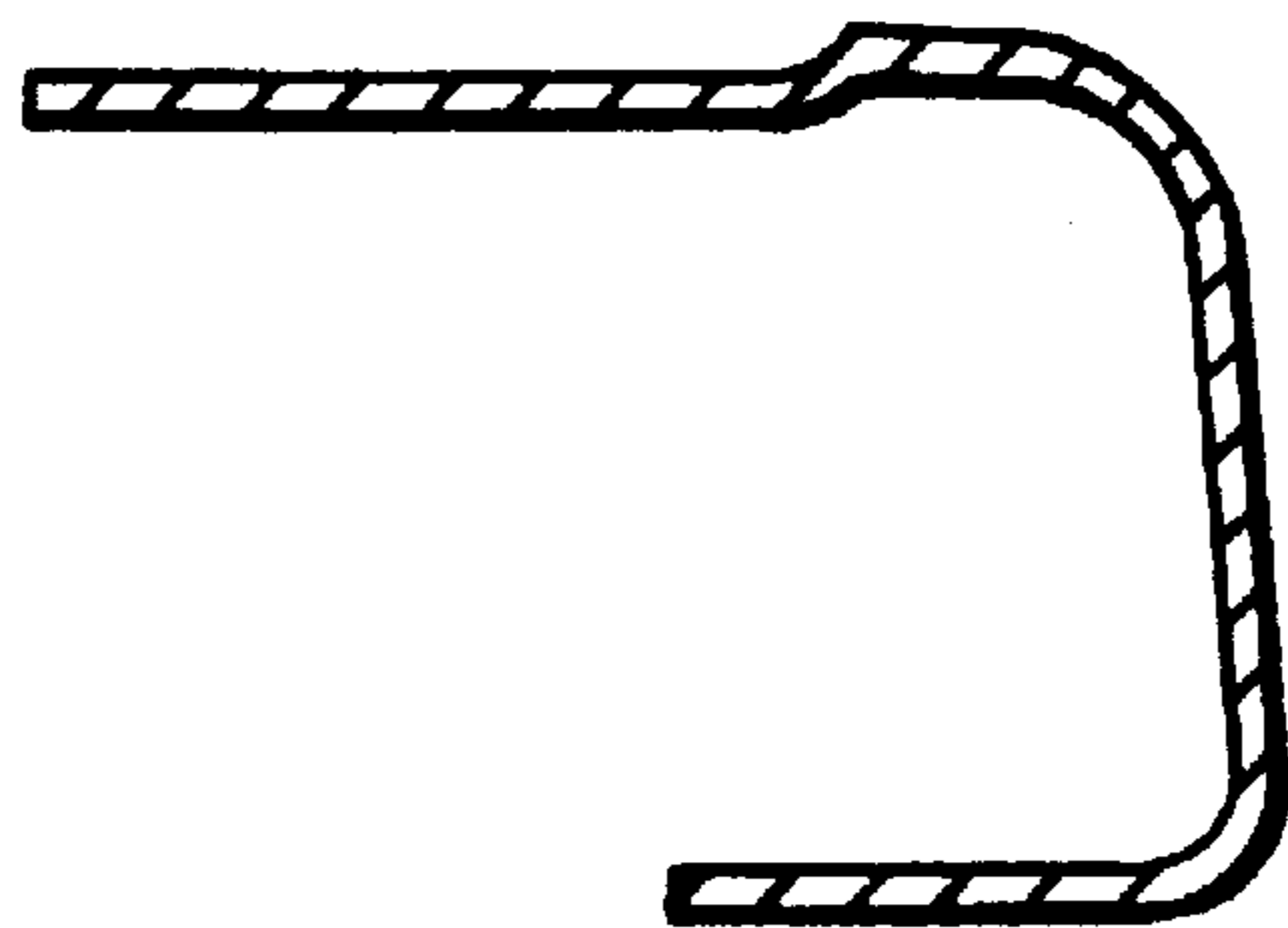

FIG. 11

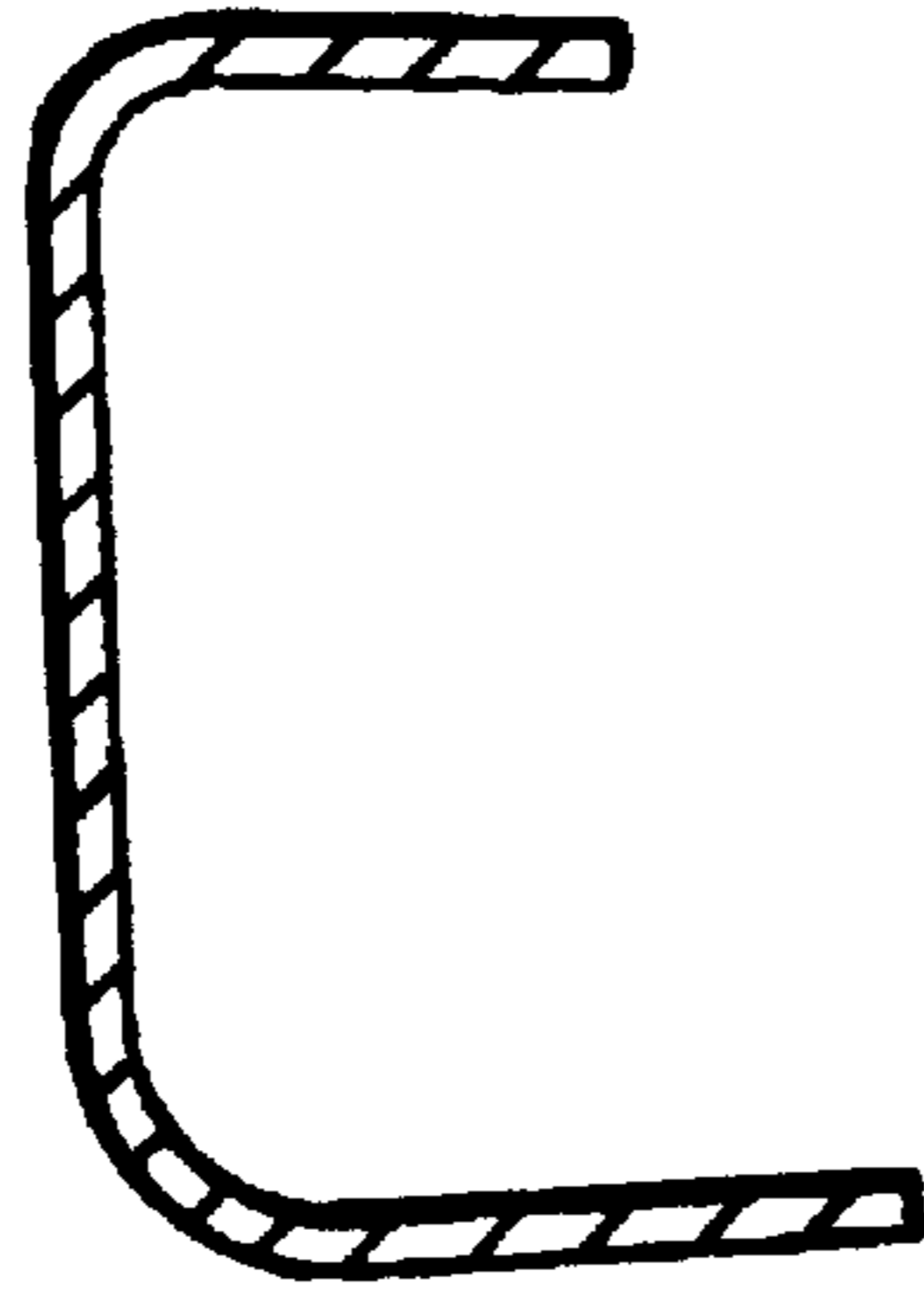

FIG. 12

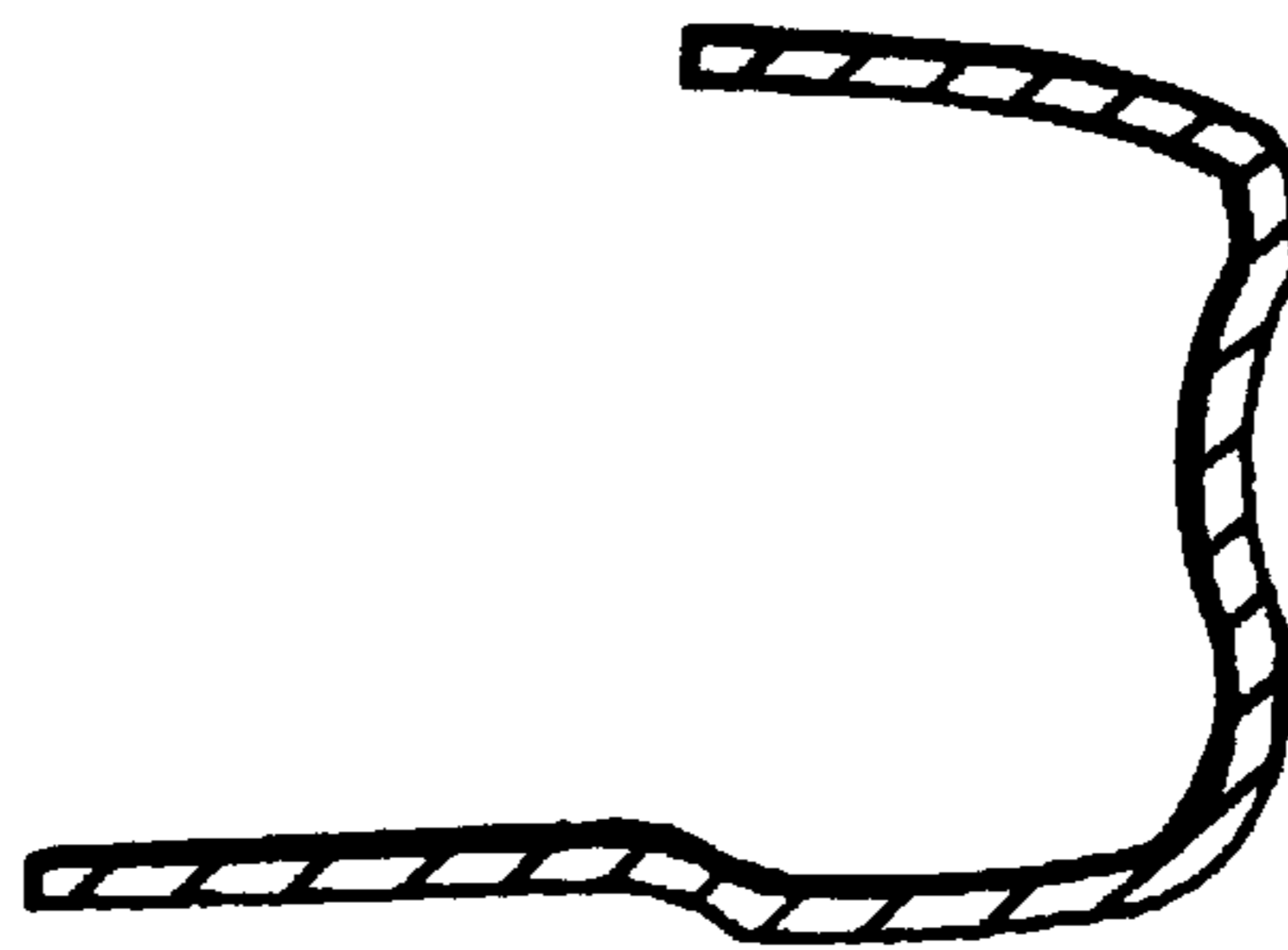

FIG. 13



FIG.14

