



US00D478537S

(12) **United States Design Patent**  
**Ono**

(10) **Patent No.:** **US D478,537 S**

(45) **Date of Patent:** **\*\* Aug. 19, 2003**

(54) **REARVIEW MIRROR FOR VEHICLES**

(75) Inventor: **Katsuyuki Ono**, Aichi-ken (JP)

(73) Assignees: **Toyota Jidosha Kabushiki Kaisha**,  
Toyota (JP); **Murakami Corporation**,  
Shizuoka (JP)

(\*\*) Term: **14 Years**

(21) Appl. No.: **29/164,189**

(22) Filed: **Jul. 22, 2002**

(30) **Foreign Application Priority Data**

May 21, 2002 (JP) ..... 2002-013505

(51) **LOC (7) Cl.** ..... **12-16**

(52) **U.S. Cl.** ..... **D12/187**

(58) **Field of Search** ..... D12/187-189;  
359/838-850, 864-880; 340/815.4, 815.5

(56) **References Cited**

**U.S. PATENT DOCUMENTS**

D351,370 S \* 10/1994 Lawlor et al. .... D12/187

D391,214 S \* 2/1998 Hook et al. .... D12/187

D451,456 S \* 12/2001 Santo ..... D12/187

D451,869 S \* 12/2001 Knapp et al. .... D12/187

\* cited by examiner

*Primary Examiner*—Melody N. Brown

(74) *Attorney, Agent, or Firm*—Oblon, Spivak, McClelland,  
Maier & Neustadt, P.C.

(57) **CLAIM**

The ornamental design for a rearview mirror for vehicles, as shown.

**DESCRIPTION**

FIG. 1 is a front elevational view of a rearview mirror for vehicles showing my new design;

FIG. 2 is a rear elevational view thereof;

FIG. 3 is a top plan view thereof;

FIG. 4 is a bottom plan view thereof;

FIG. 5 is a right side elevational view thereof;

FIG. 6 is a sectional view along the line 6—6 in FIG. 1;

FIG. 7 is a sectional view along the line 7—7 in FIG. 1;

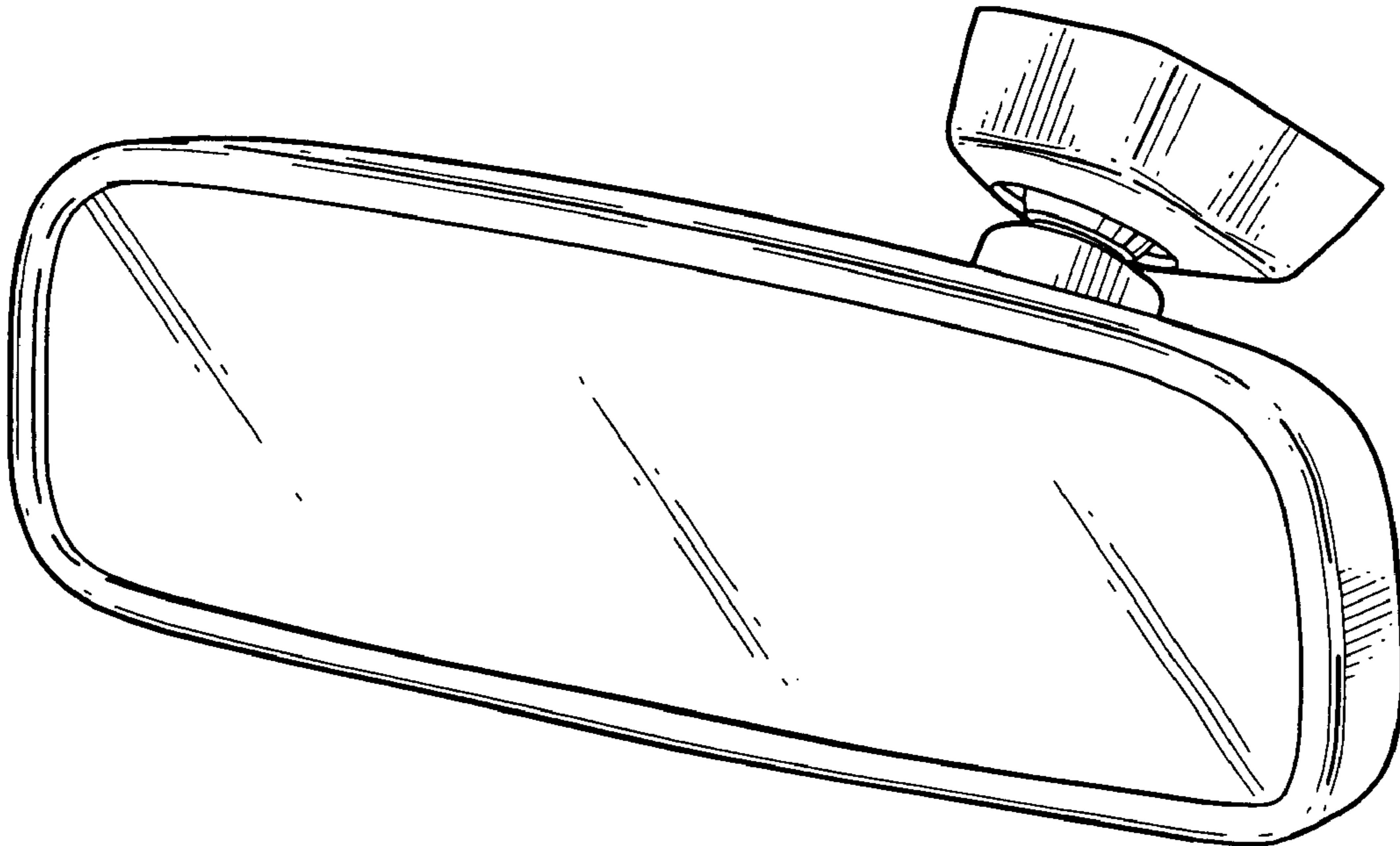
FIG. 8 is a sectional view along the line 8—8 in FIG. 4;

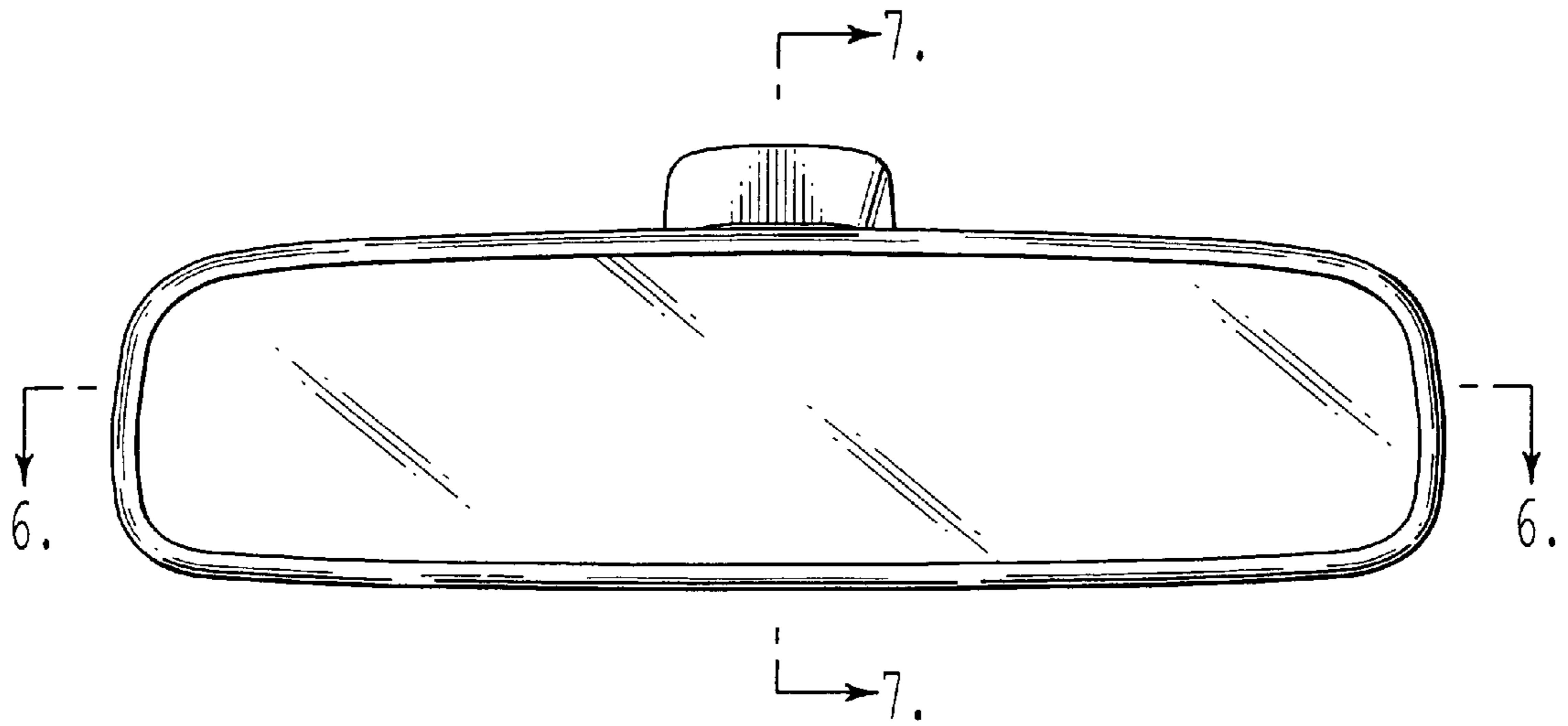
FIG. 9 is a referential cross sectional view of FIG. 7, the broken lines of which are shown for illustrative purposes only and form no part of the claimed design;

FIG. 10 is a front perspective view thereof; and,

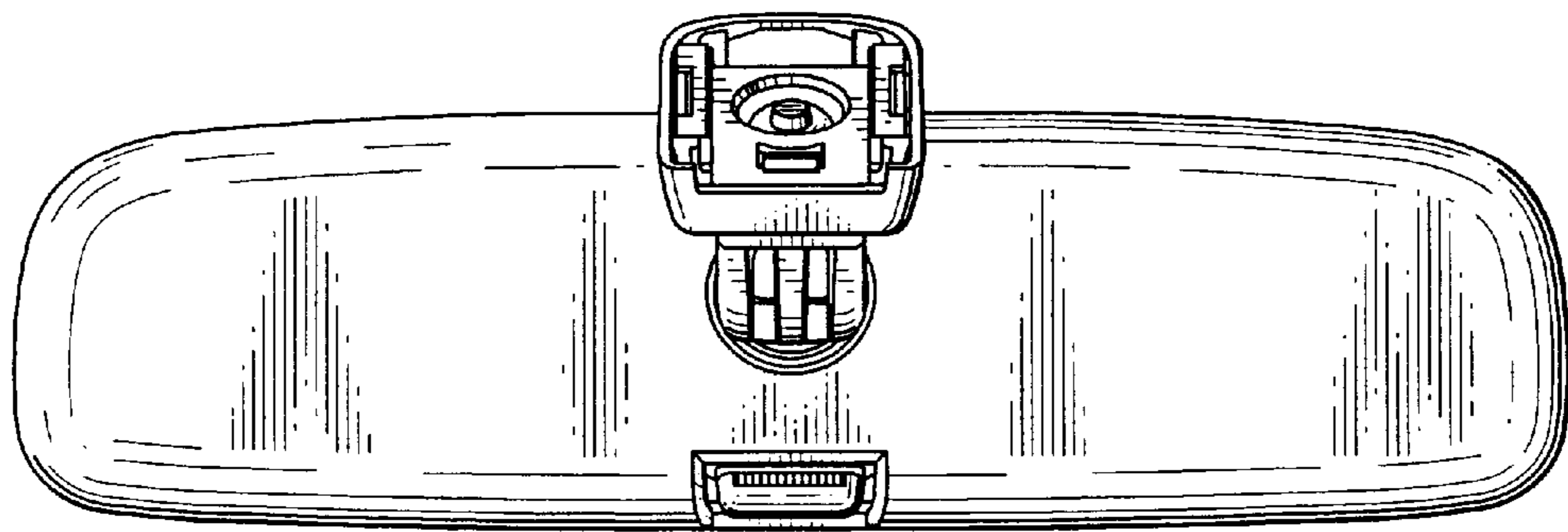
FIG. 11 is a rear perspective view thereof.

**1 Claim, 4 Drawing Sheets**

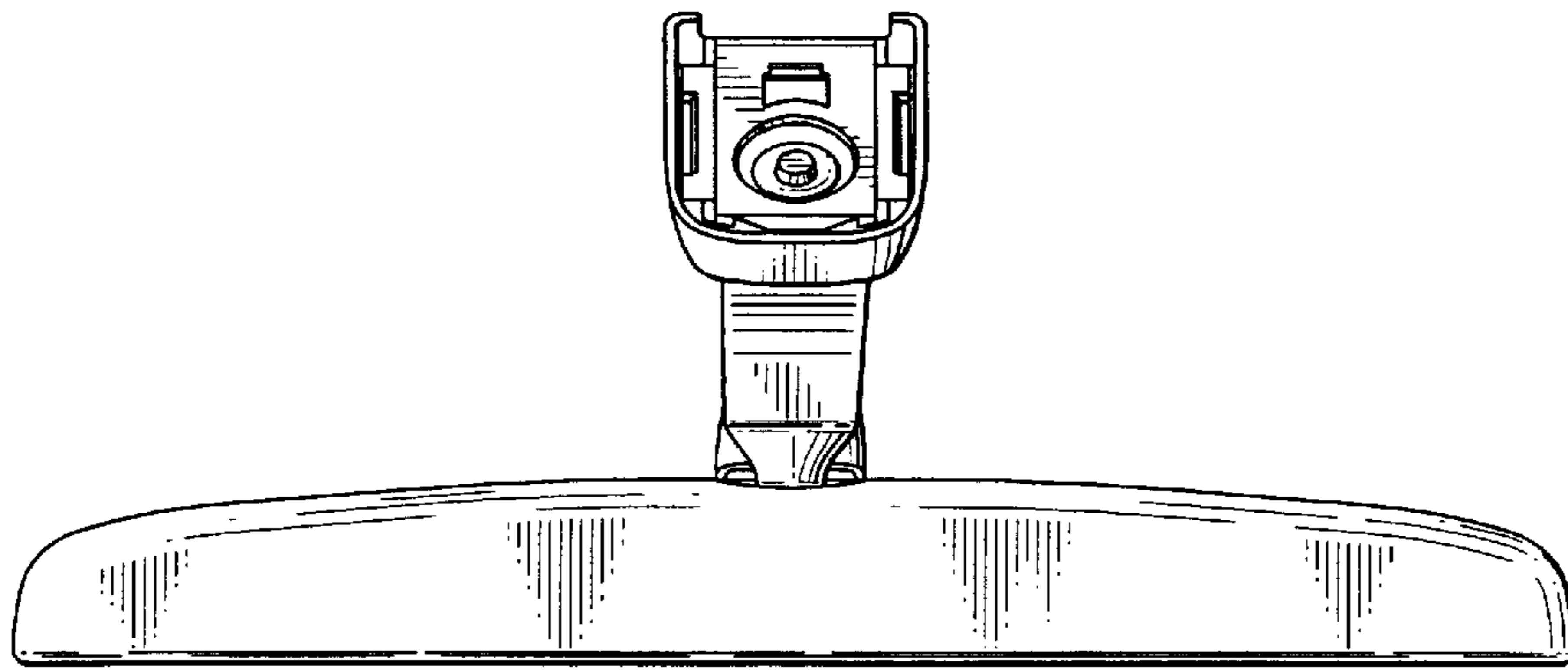




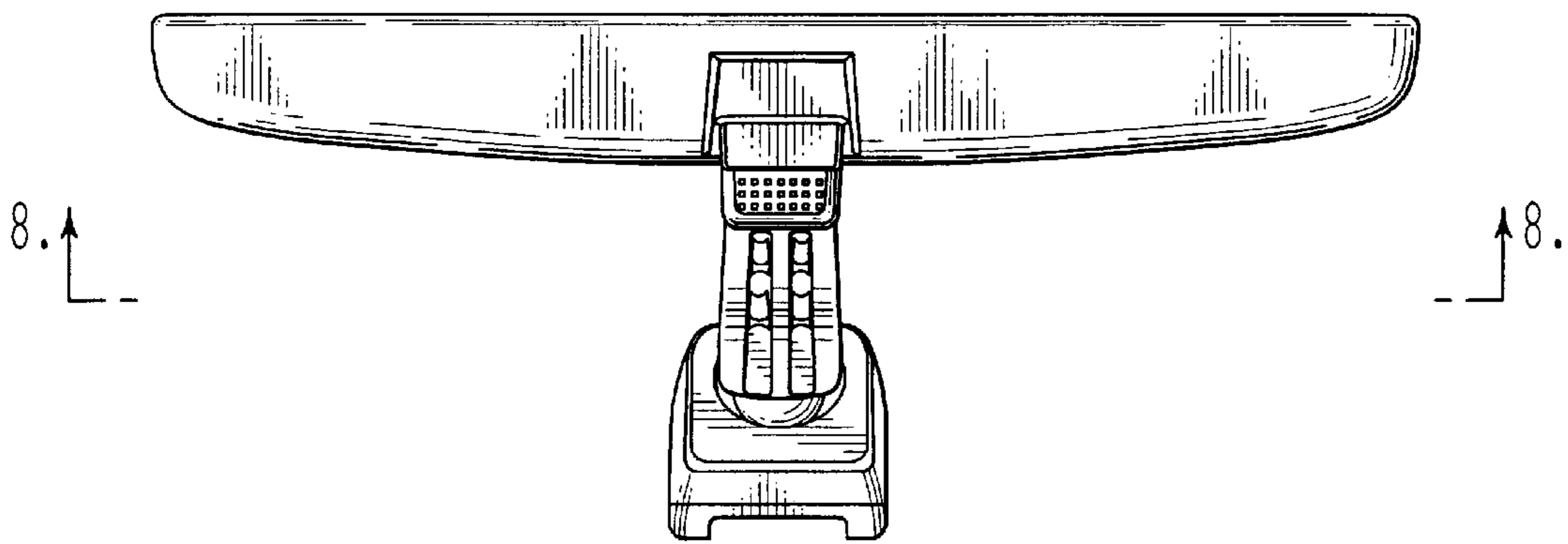
*FIG. 1*



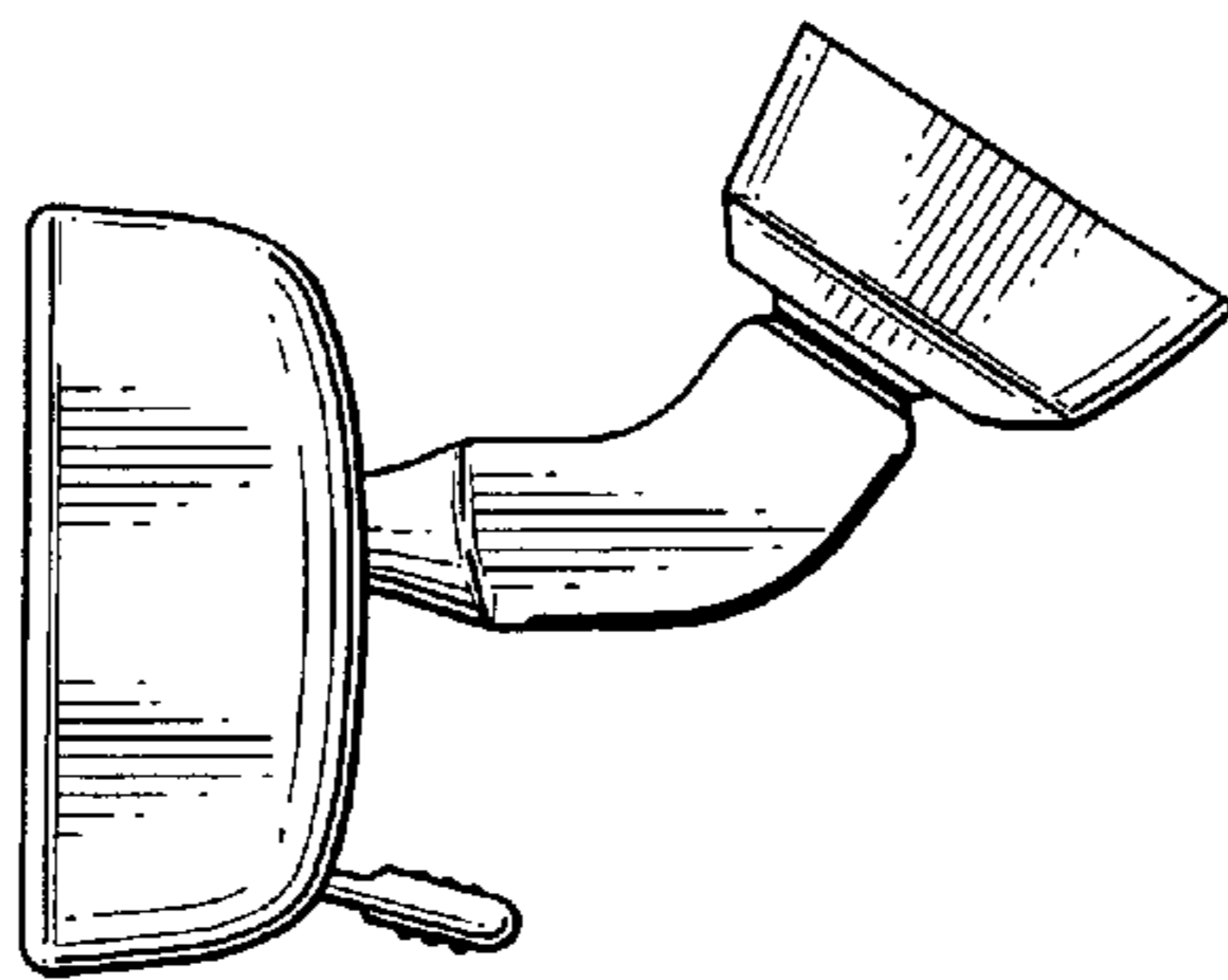
*FIG. 2*



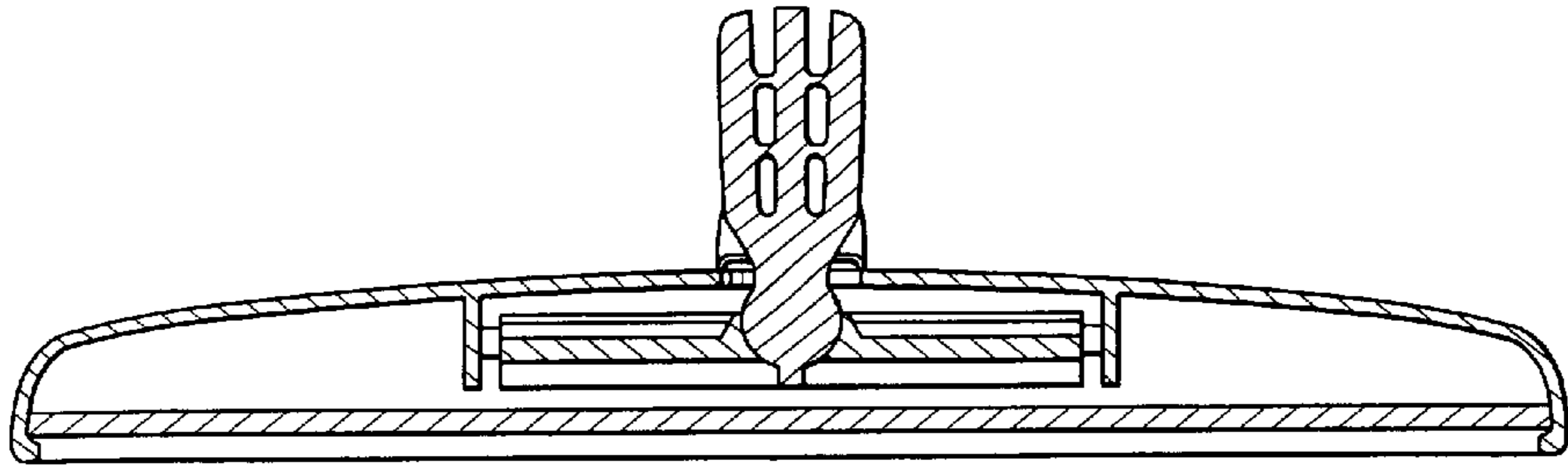
*FIG. 3*



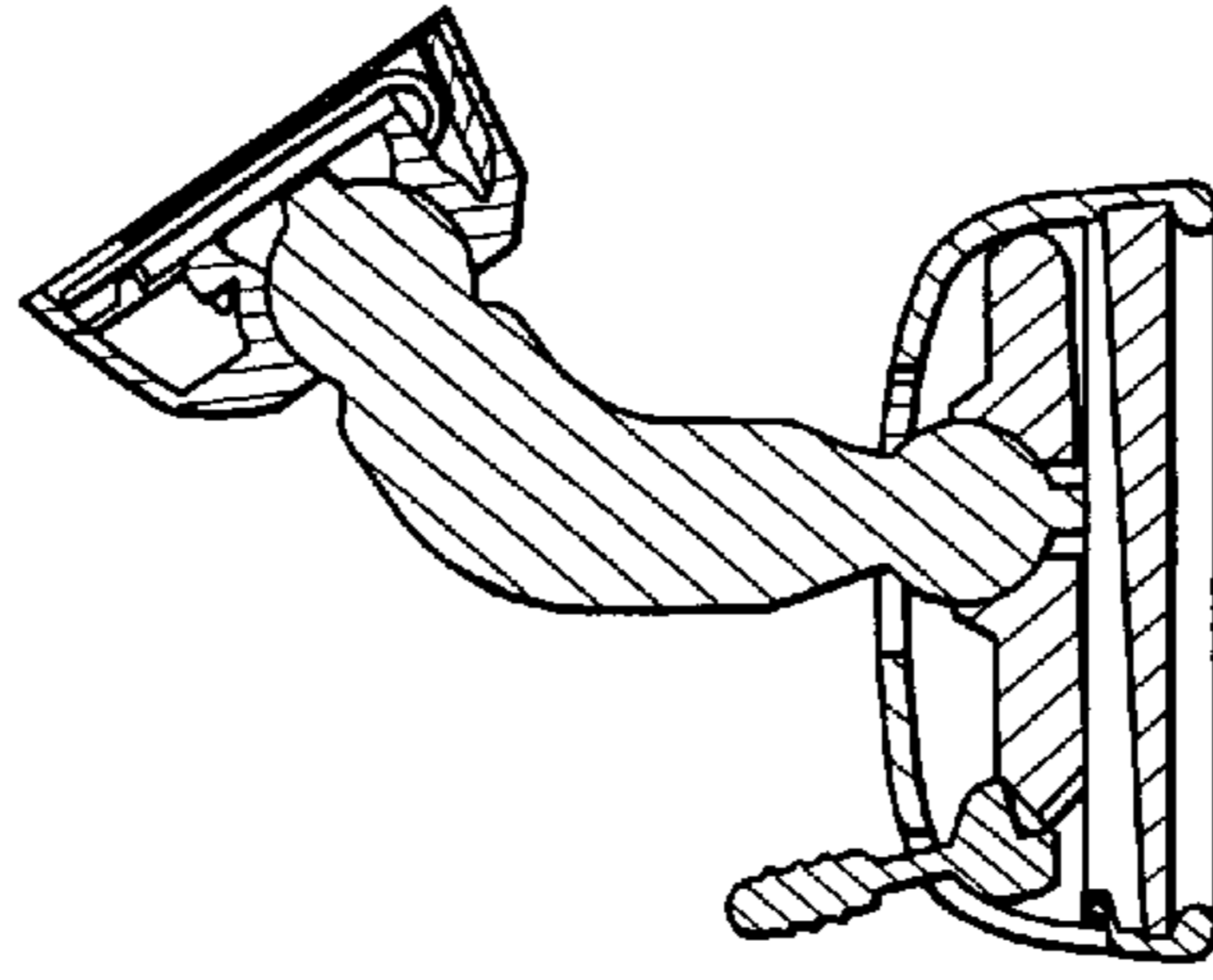
*FIG. 4*



*FIG. 5*



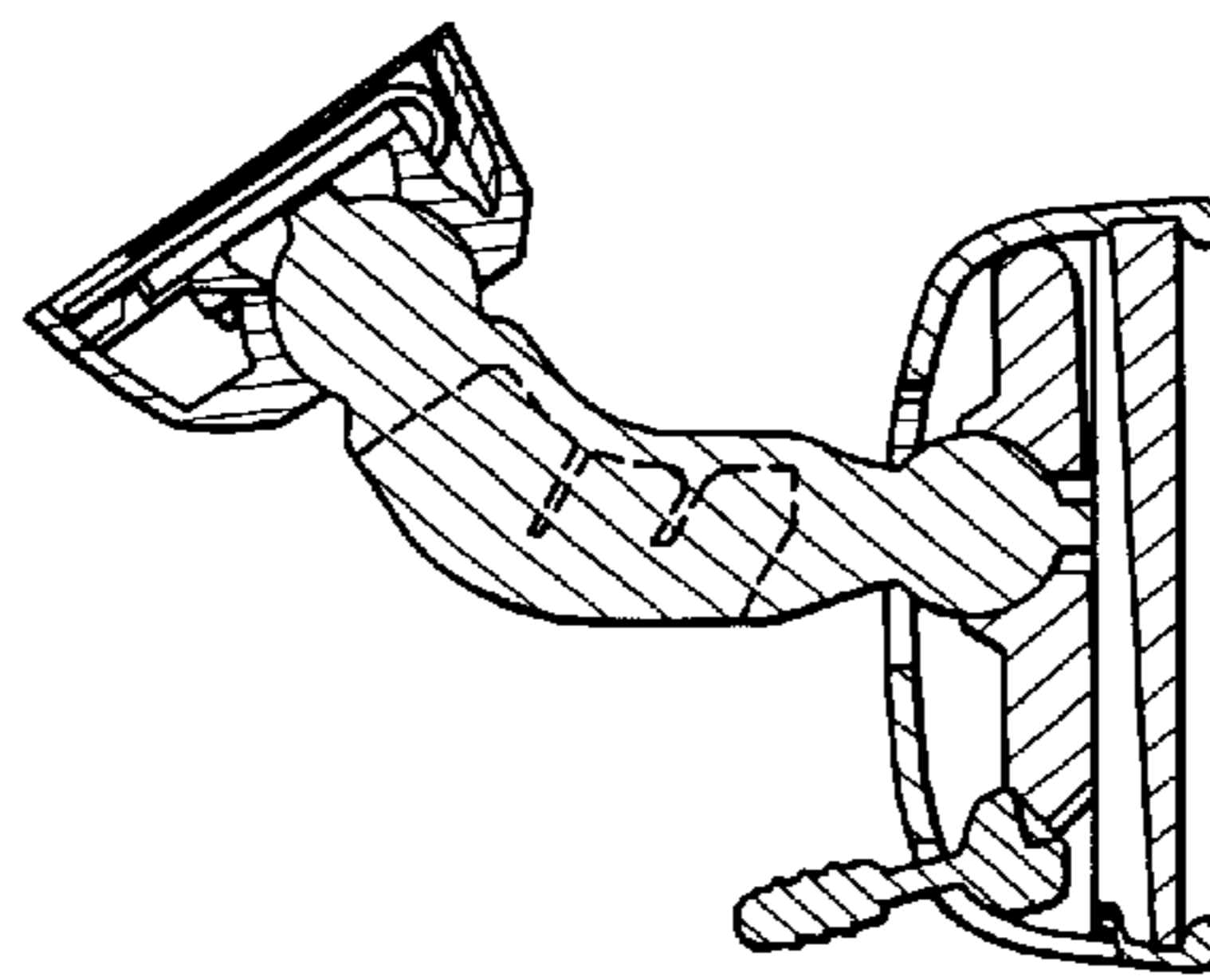
*FIG. 6*



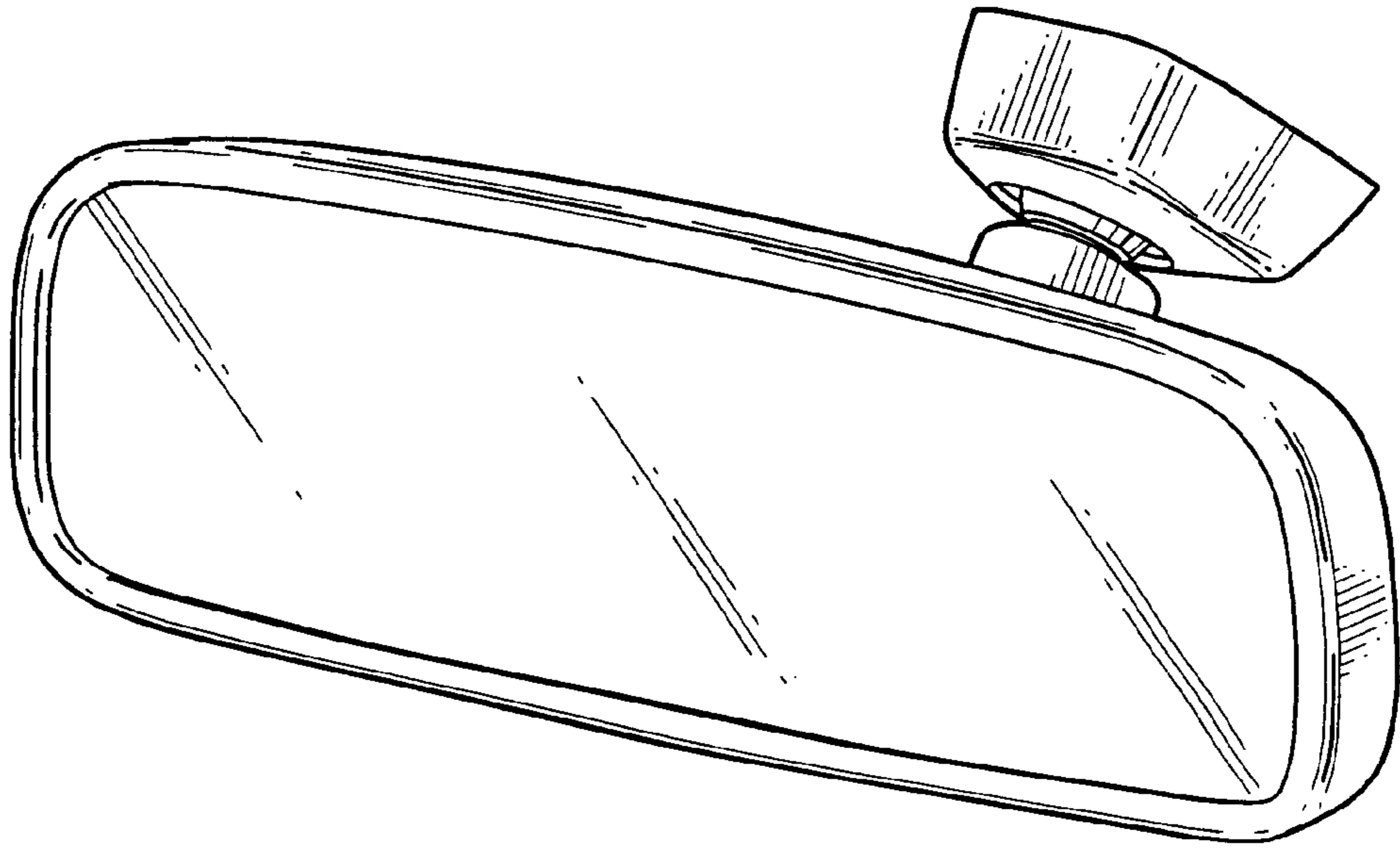
*FIG. 7*



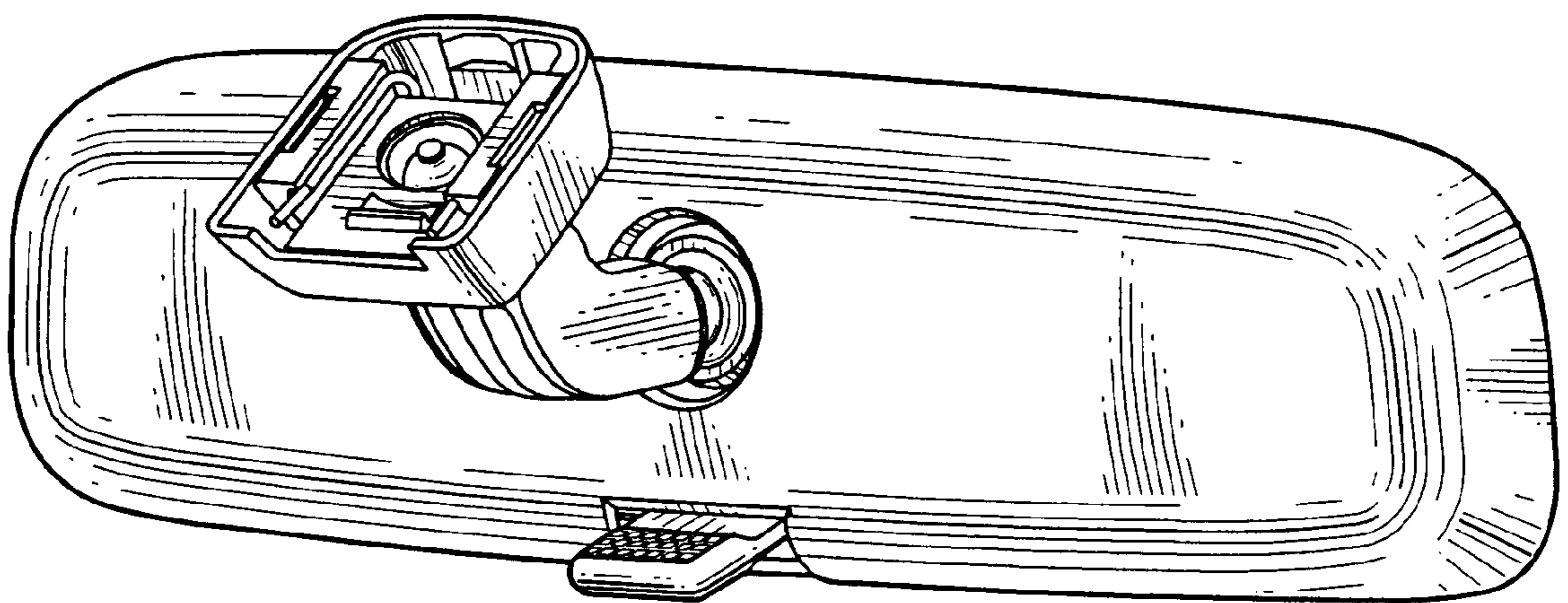
*FIG. 8*



*FIG. 9*



*FIG. 10*



*FIG. 11*