



US00D478533S

(12) **United States Design Patent**
Nicholas et al.

(10) **Patent No.:** **US D478,533 S**

(45) **Date of Patent:** **** Aug. 19, 2003**

(54) **AUTOMOBILE BODY**

(75) Inventors: **Michael Nicholas**, Troy, MI (US);
Jaehak Namgoong, Sterling Heights,
MI (US); **Brandon Faurote**, Rochester,
MI (US); **L. John Ozark**, Grosse
Pointe Woods, MI (US); **Lance R**
Wagner, Lake Orion, MI (US); **Jeffrey**
I Godshall, Royal Oak, MI (US)

(73) Assignee: **DaimlerChrysler Corporation**, Auburn
Hills, MI (US)

(**) Term: **14 Years**

(21) Appl. No.: **29/172,969**

(22) Filed: **Dec. 19, 2002**

(51) **LOC (7) Cl.** **12-16**

(52) **U.S. Cl.** **D12/91**

(58) **Field of Search** D12/90-92, 86;
296/185

(56) **References Cited**

U.S. PATENT DOCUMENTS

D430,821 S * 9/2000 Carlson et al. D12/92

D455,983 S * 4/2002 Carlson D12/92

D456,746 S * 5/2002 Carlson D12/91

D463,758 S * 10/2002 Meadows et al. D12/91

* cited by examiner

Primary Examiner—Melody N. Brown
(74) *Attorney, Agent, or Firm*—Ralph E. Smith

(57) **CLAIM**

The ornamental design for an automobile body, as shown
and described.

DESCRIPTION

FIG. 1 is a front perspective view of an automobile body
showing our new design;

FIG. 2 is a side view thereof;

FIG. 3 is a rear perspective view thereof;

FIG. 4 is a front view thereof; and,

FIG. 5 is a rear view thereof.

It will be understood that the roof of the automobile body is
plain and unornamental, and further that broken lines pre-
sented in the drawings are for illustration only, and do not
form a part of the claimed design.

1 Claim, 5 Drawing Sheets

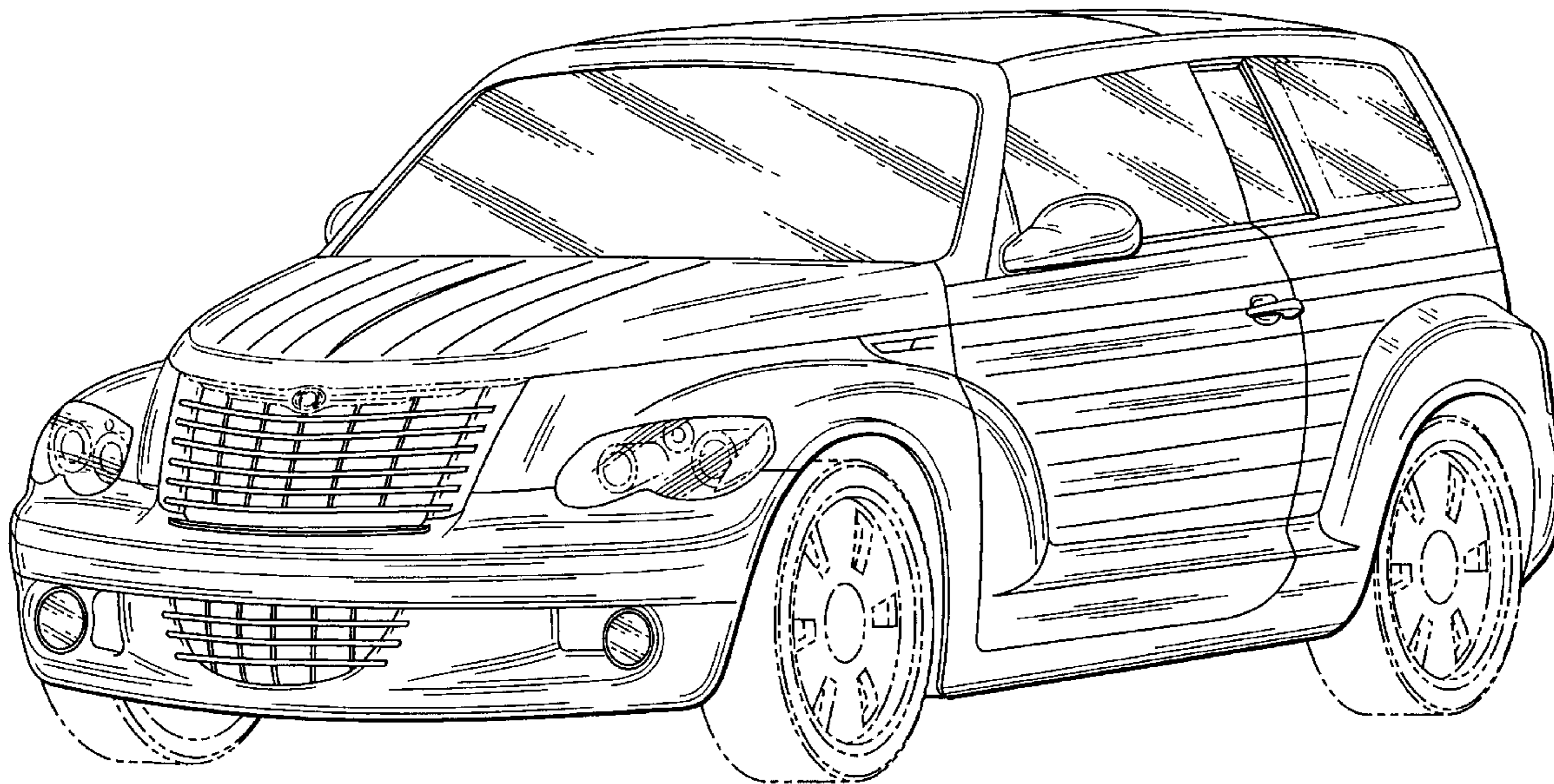

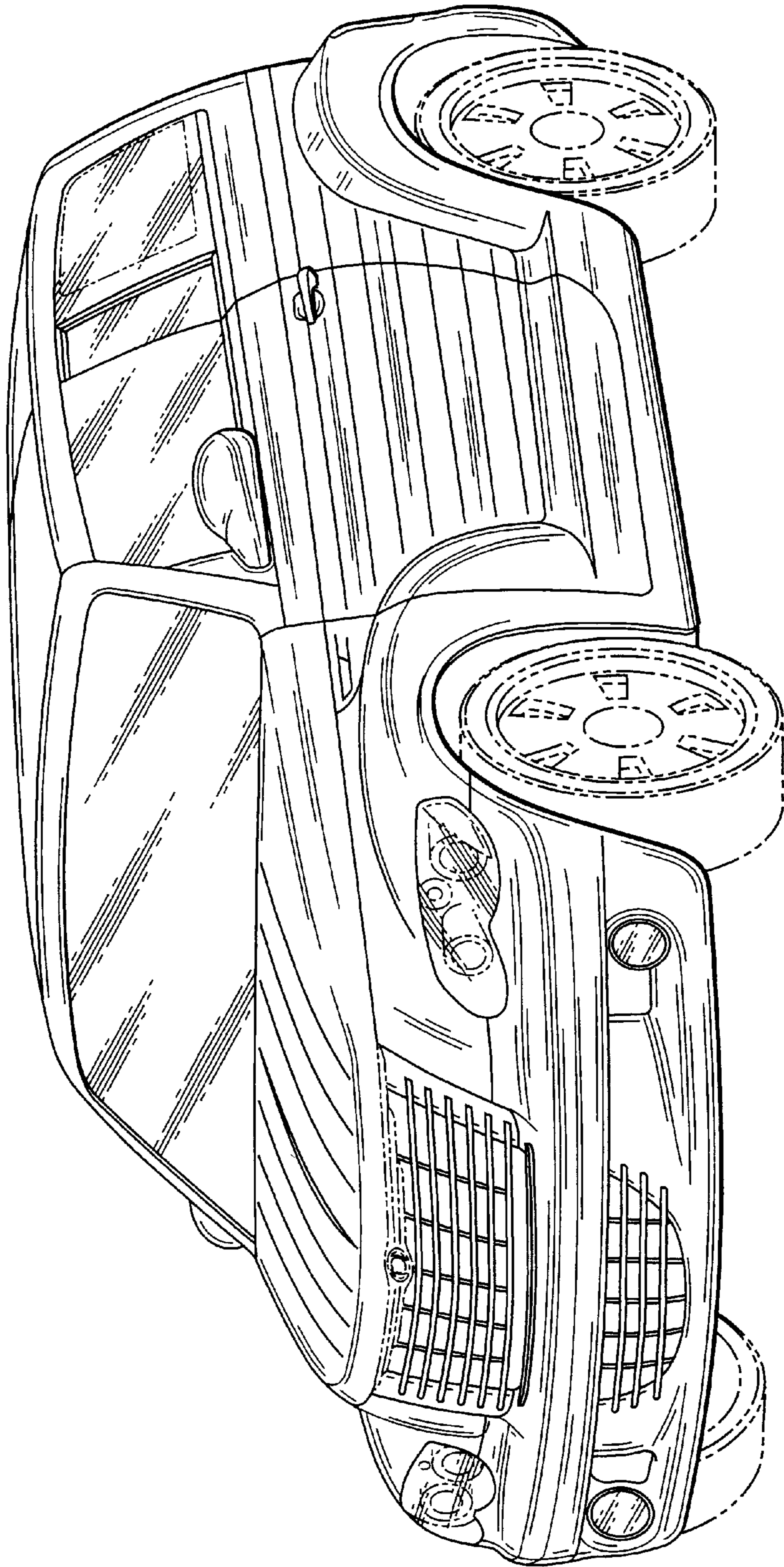

Fig. 1

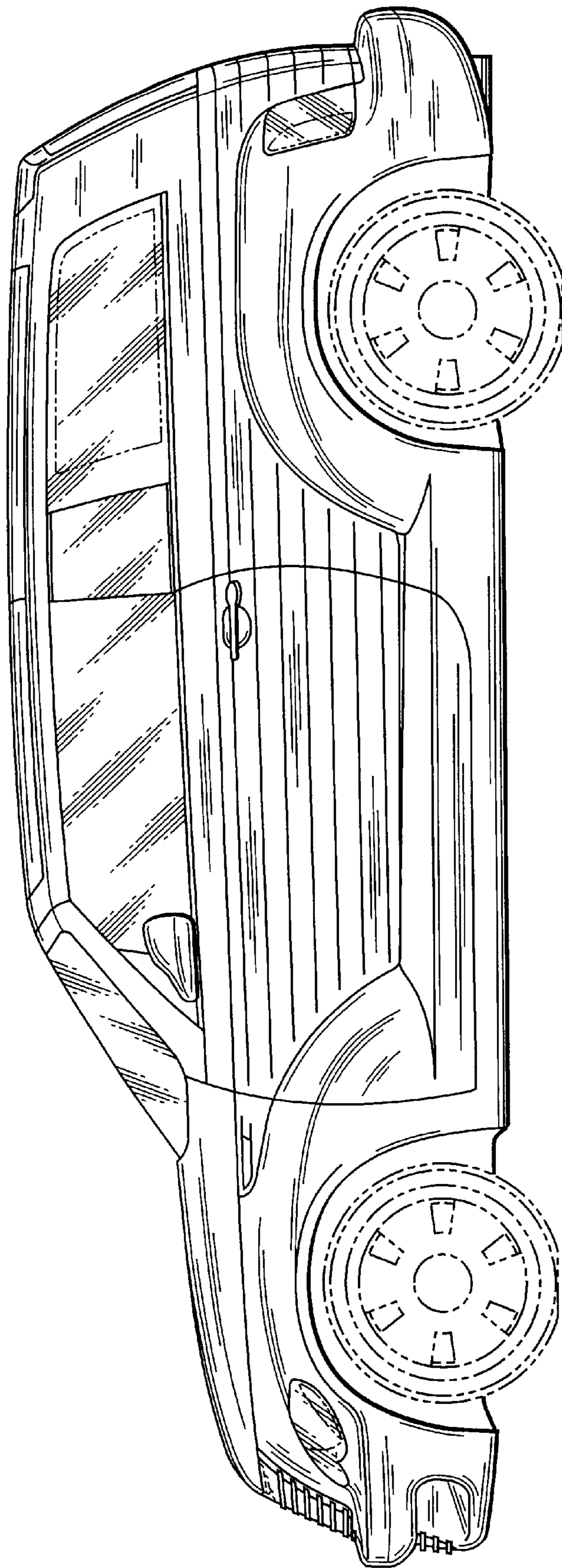

Fig. 2

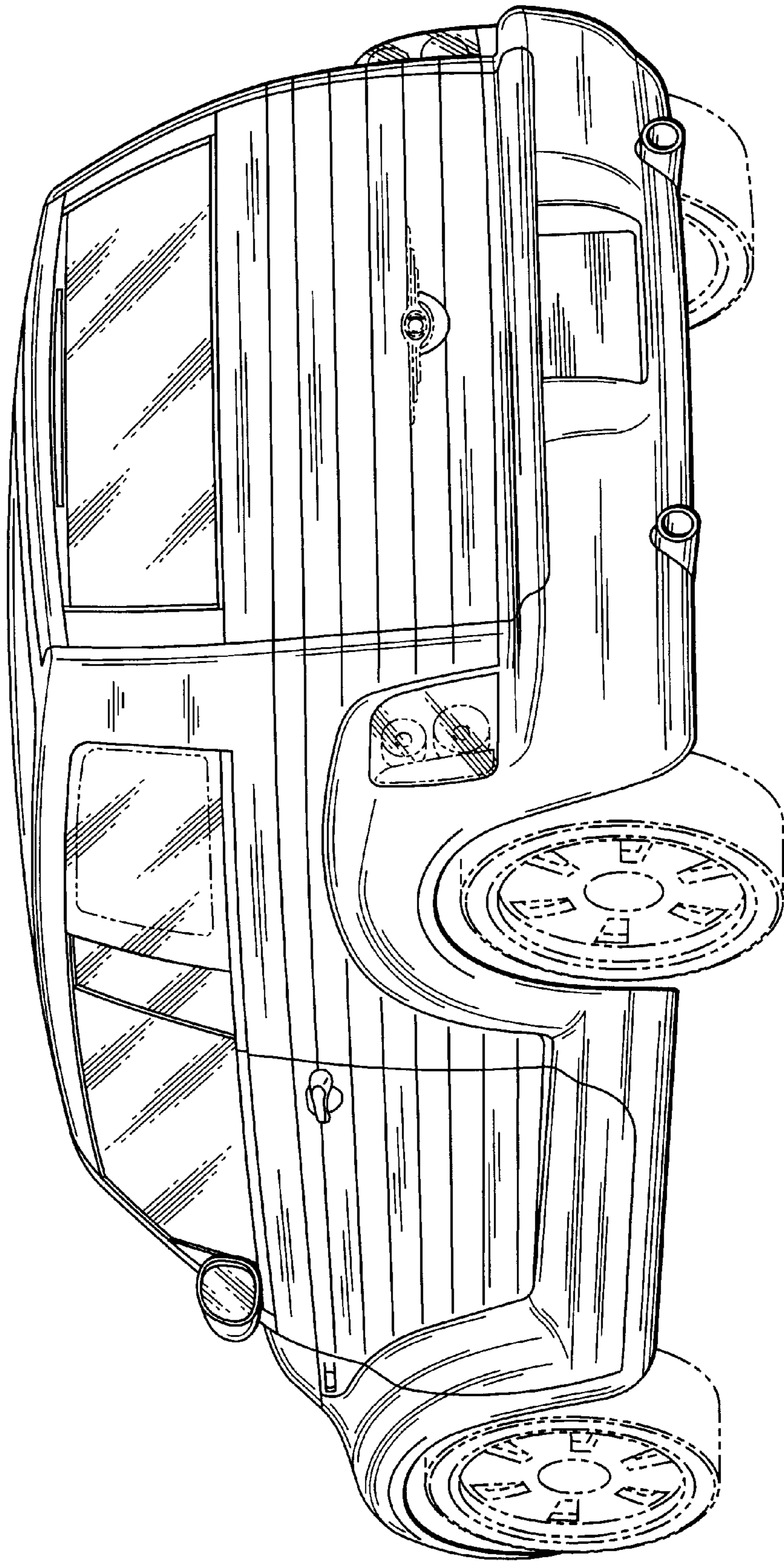

Fig. 3

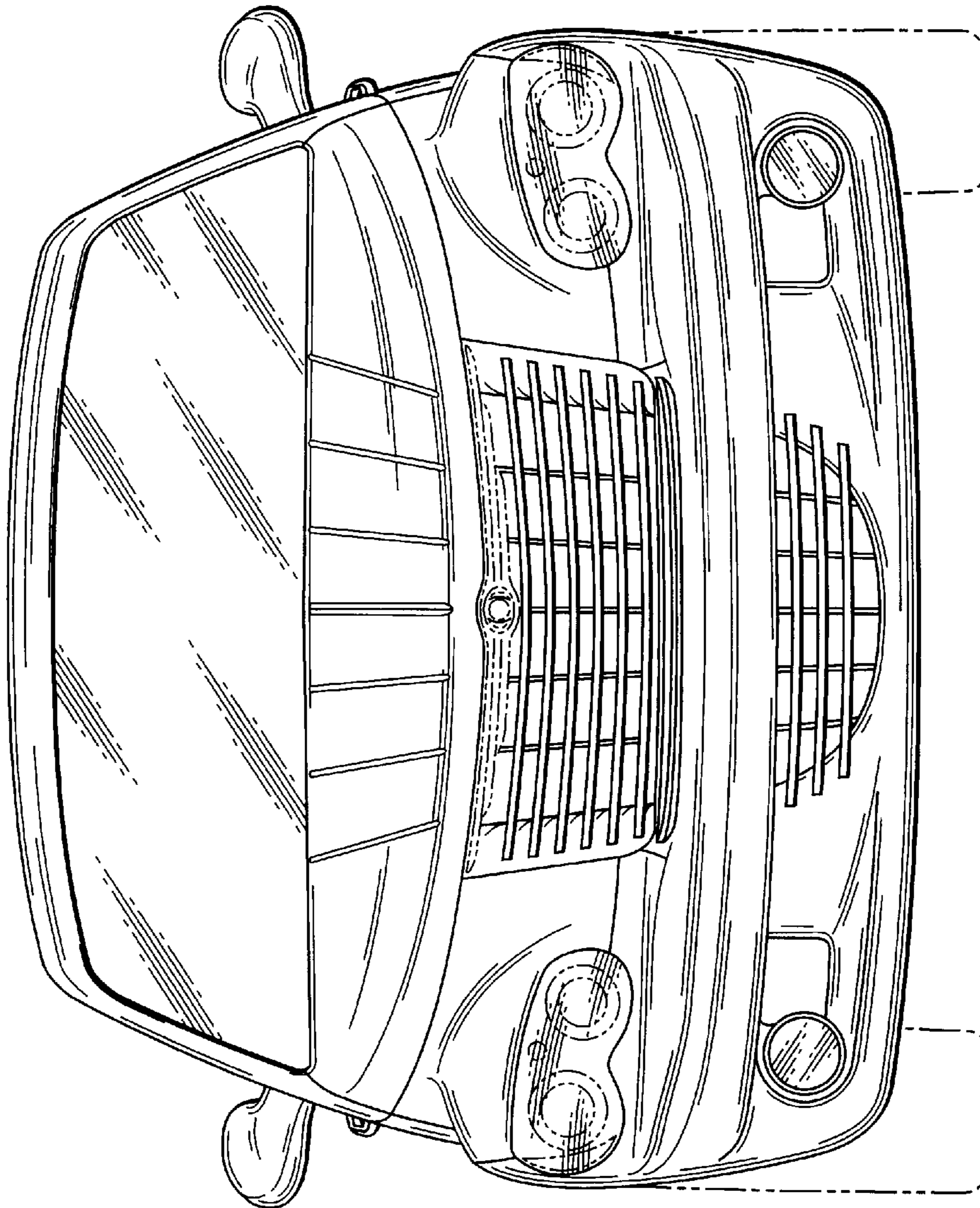

Fig. 4

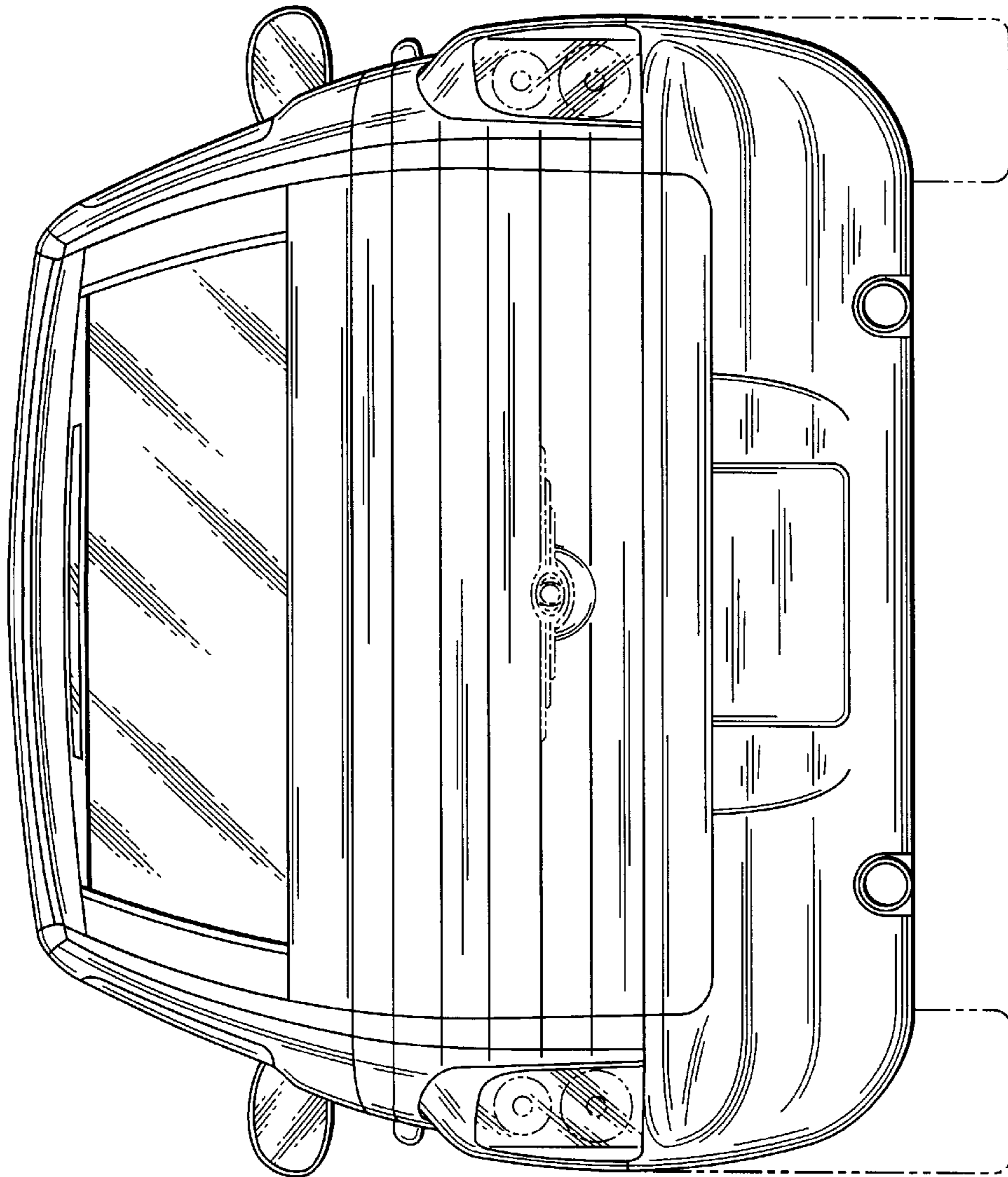

Fig. 5