



US00D478521S

(12) **United States Design Patent**
Harju

(10) **Patent No.:** **US D478,521 S**

(45) **Date of Patent:** **** Aug. 19, 2003**

(54) **ELECTRICAL MEASUREMENT INSTRUMENT CASE**

D446,734 S * 8/2001 Kuramoto D10/78

* cited by examiner

(76) **Inventor:** **Rey P. Harju**, 3839 San Pablo Dr., Fullerton, CA (US) 92835

Primary Examiner—Antoine Duval Davis
(74) *Attorney, Agent, or Firm*—Lynn & Lynn

(**) **Term:** **14 Years**

(57) **CLAIM**

(21) **Appl. No.:** **29/168,062**

I claim the ornamental design for an electrical measurement instrument case, as shown and described.

(22) **Filed:** **Sep. 24, 2002**

DESCRIPTION

(51) **LOC (7) Cl.** **10-04**

(52) **U.S. Cl.** **D10/78**

(58) **Field of Search** D10/78; 324/72.5, 324/99 D, 110, 114, 115, 121, 122, 133, 149, 98, 99 R, 100; 379/21-27

FIG. 1 is a perspective view showing my new design;
FIG. 2 is a top plan view thereof;
FIG. 3 is a right side elevation view thereof;
FIG. 4 bottom plan view thereof;
FIG. 5 is a front end elevation thereof; and,
FIG. 6 is a rear end elevation view thereof.
The left side elevation of my new design is identical to the right side elevation.

(56) **References Cited**

U.S. PATENT DOCUMENTS

D414,124 S * 9/1999 Yang D10/78

1 Claim, 3 Drawing Sheets

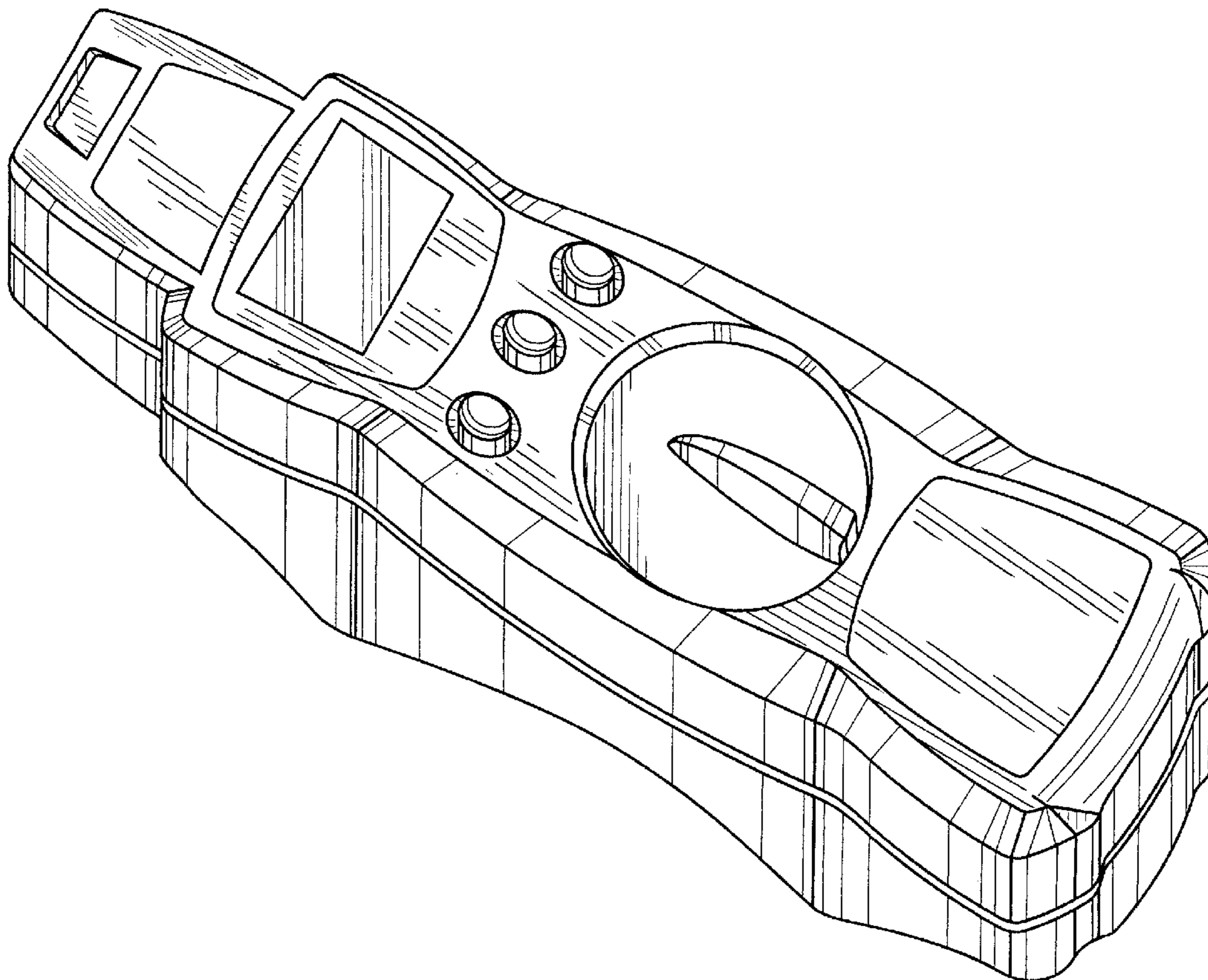

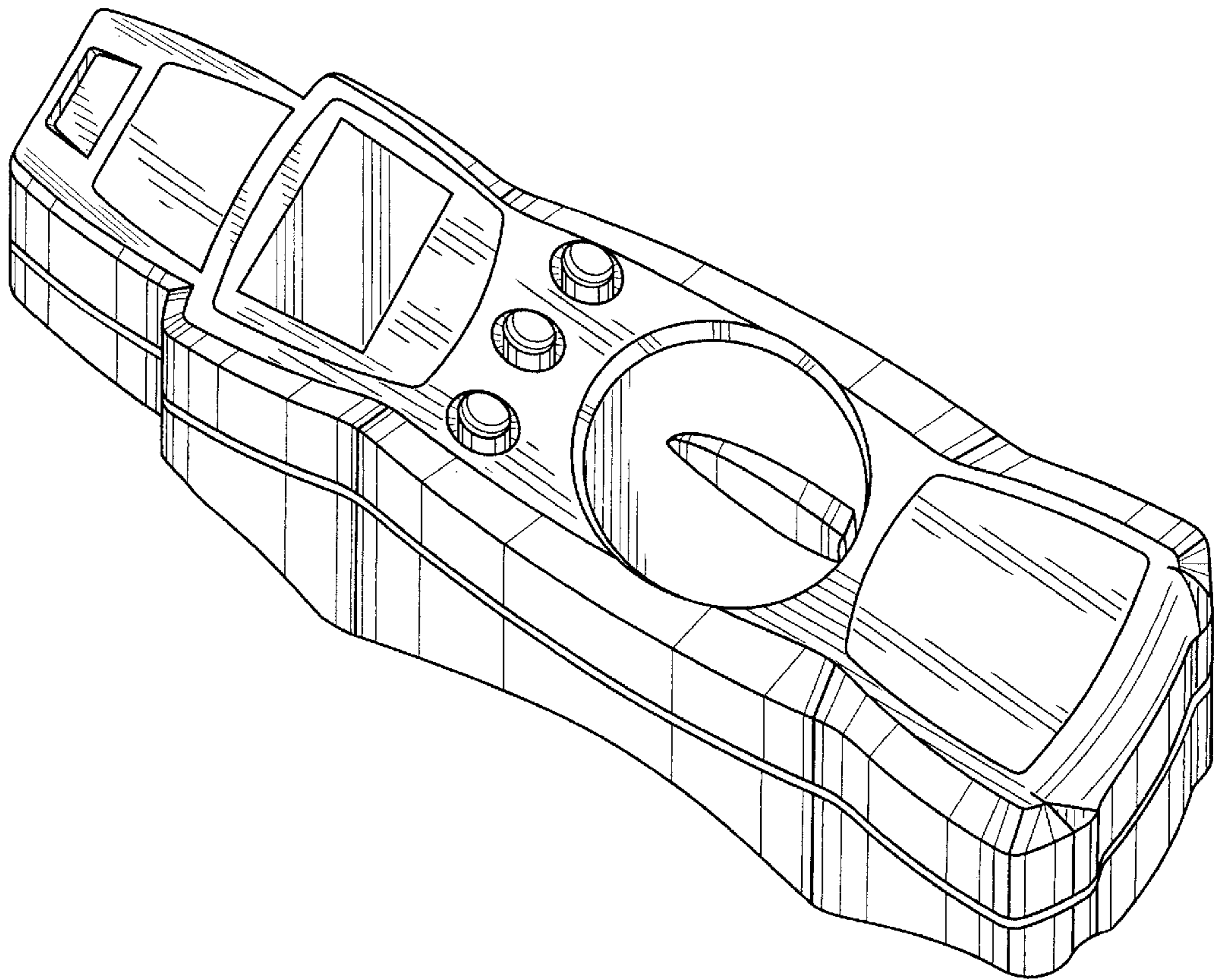

FIG. 1

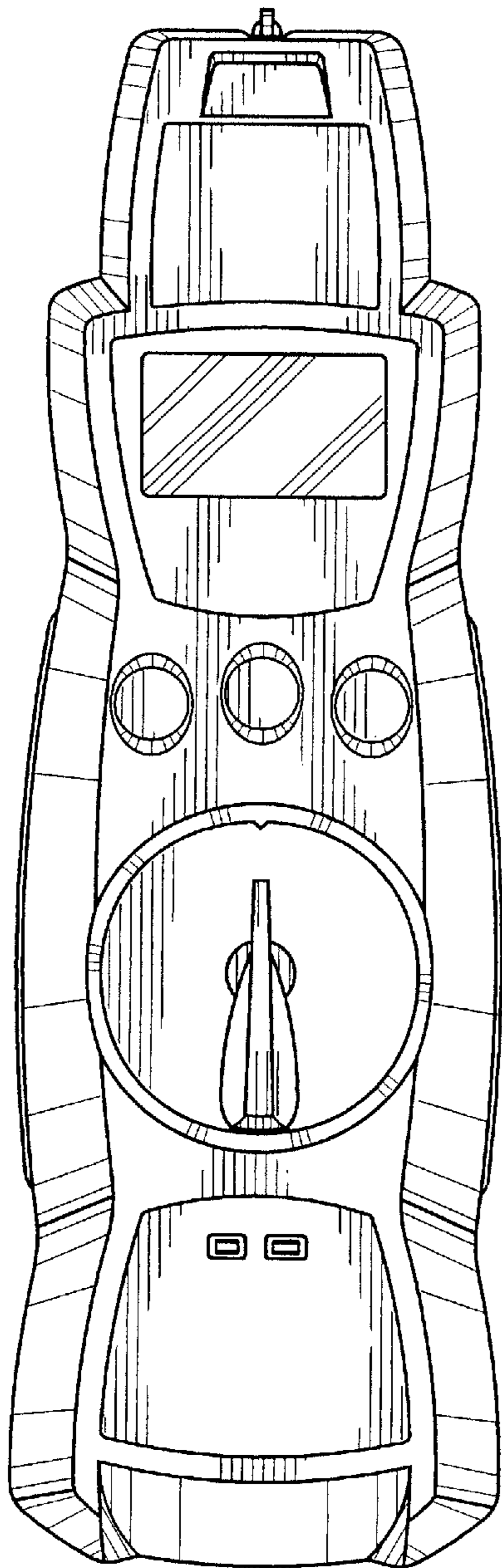

FIG. 2

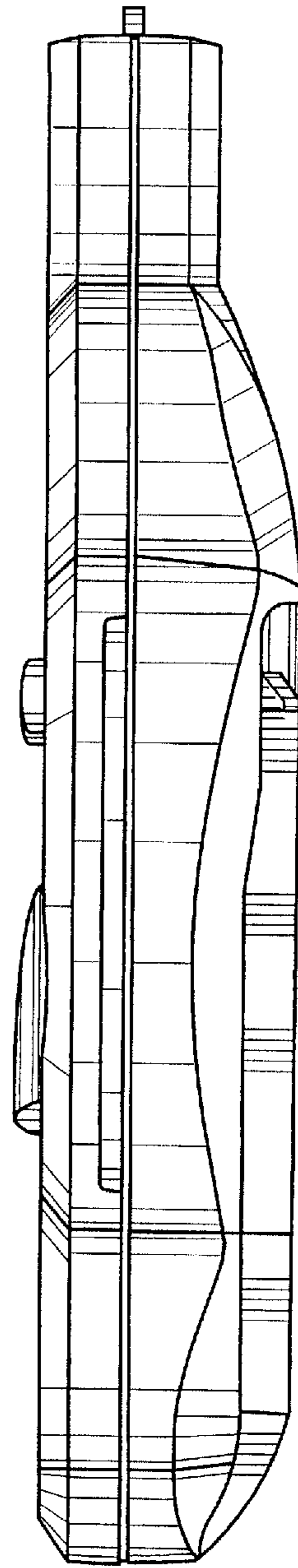

FIG. 3

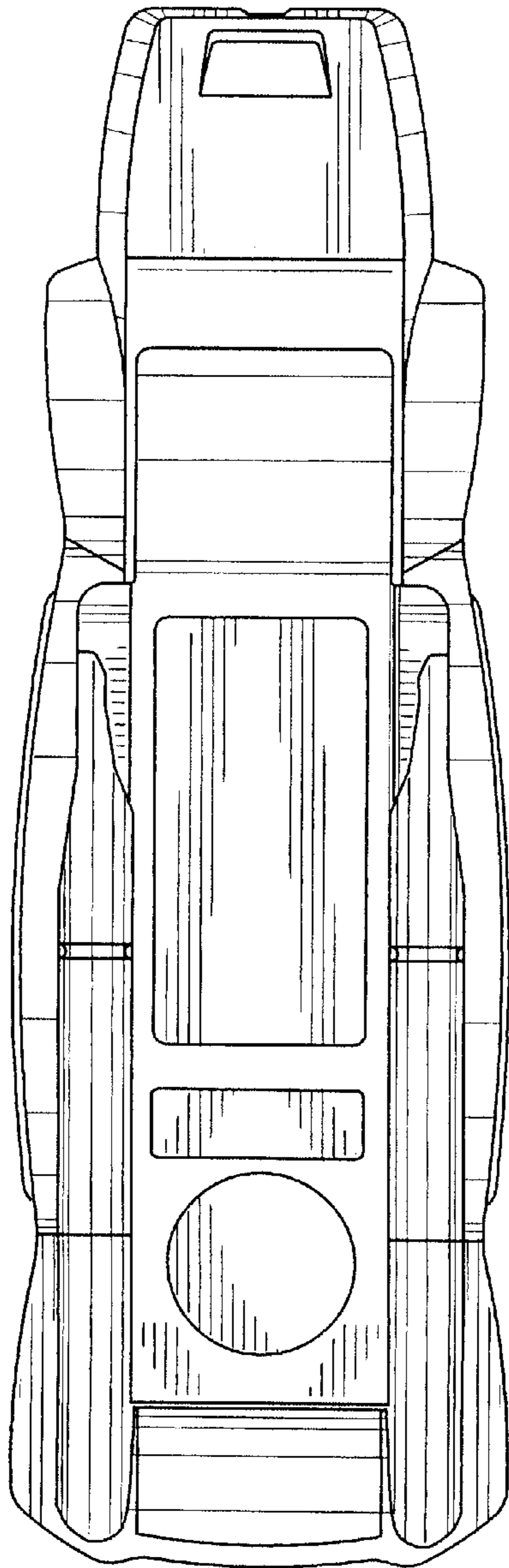

FIG. 4

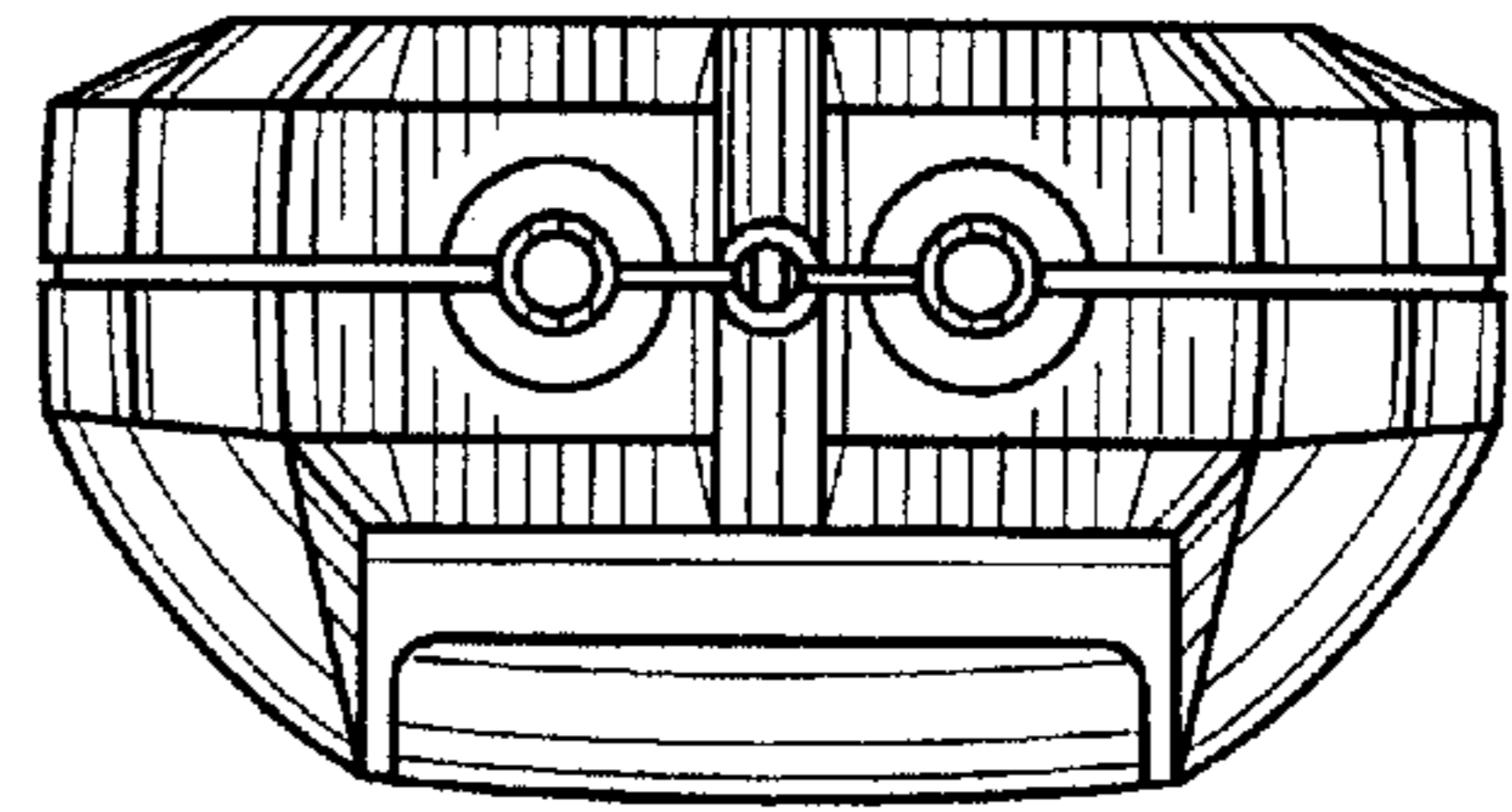

FIG. 5

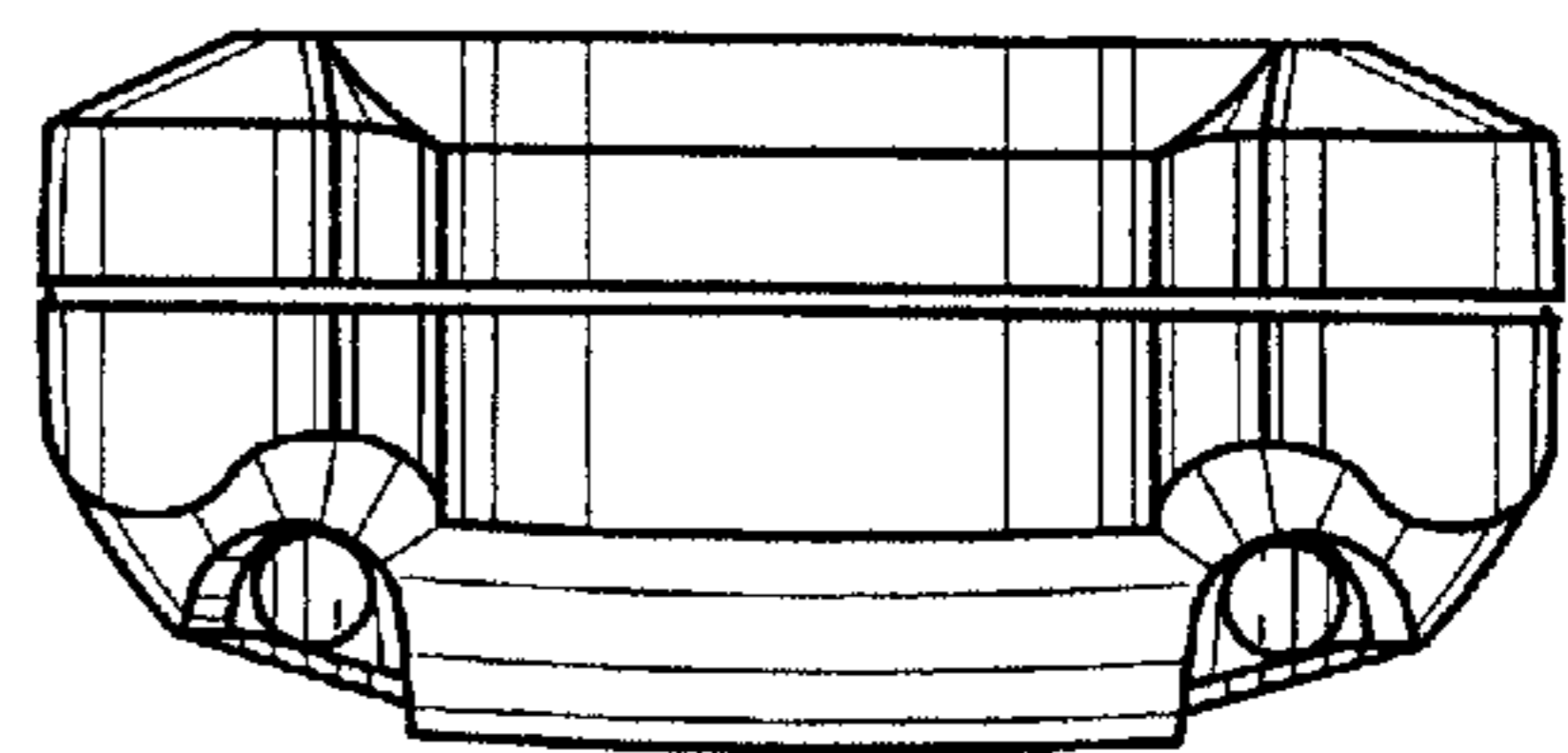

FIG. 6