



US00D478118S

(12) **United States Design Patent**  
**Neri**

(10) **Patent No.:** **US D478,118 S**

(45) **Date of Patent:** **\*\* Aug. 5, 2003**

(54) **DRIVE HUB ASSEMBLY FOR A THERMAL TRANSFER PRINTER**

(75) **Inventor:** **Joel Neri, Youngstown, NY (US)**

(73) **Assignee:** **International Imaging Materials, Inc., Amherst, NY (US)**

(\*\*) **Term:** **14 Years**

(21) **Appl. No.:** **29/155,259**

(22) **Filed:** **Feb. 6, 2002**

(51) **LOC (7) Cl.** ..... **16-03**

(52) **U.S. Cl.** ..... **D18/40**

(58) **Field of Search** ..... D18/12, 40, 43,  
D18/56; 400/207, 208, 208.1; 347/86; 399/24-28,  
110-117, 252-262

(56) **References Cited**

**U.S. PATENT DOCUMENTS**

4,688,926	A *	8/1987	Manno	399/260
4,702,631	A *	10/1987	Watanabe	400/208
5,269,612	A *	12/1993	Shimoha et al.	400/207
5,492,422	A *	2/1996	Kondo	400/208.1
5,795,083	A *	8/1998	Gallagher	400/207
6,238,043	B1 *	5/2001	Silverbrook	347/86
6,238,044	B1 *	5/2001	Silverbrook et al.	347/86

\* cited by examiner

*Primary Examiner*—Caron D. Veynar

(74) *Attorney, Agent, or Firm*—Greenwald & Basch LLP;  
Howard J. Greenwald

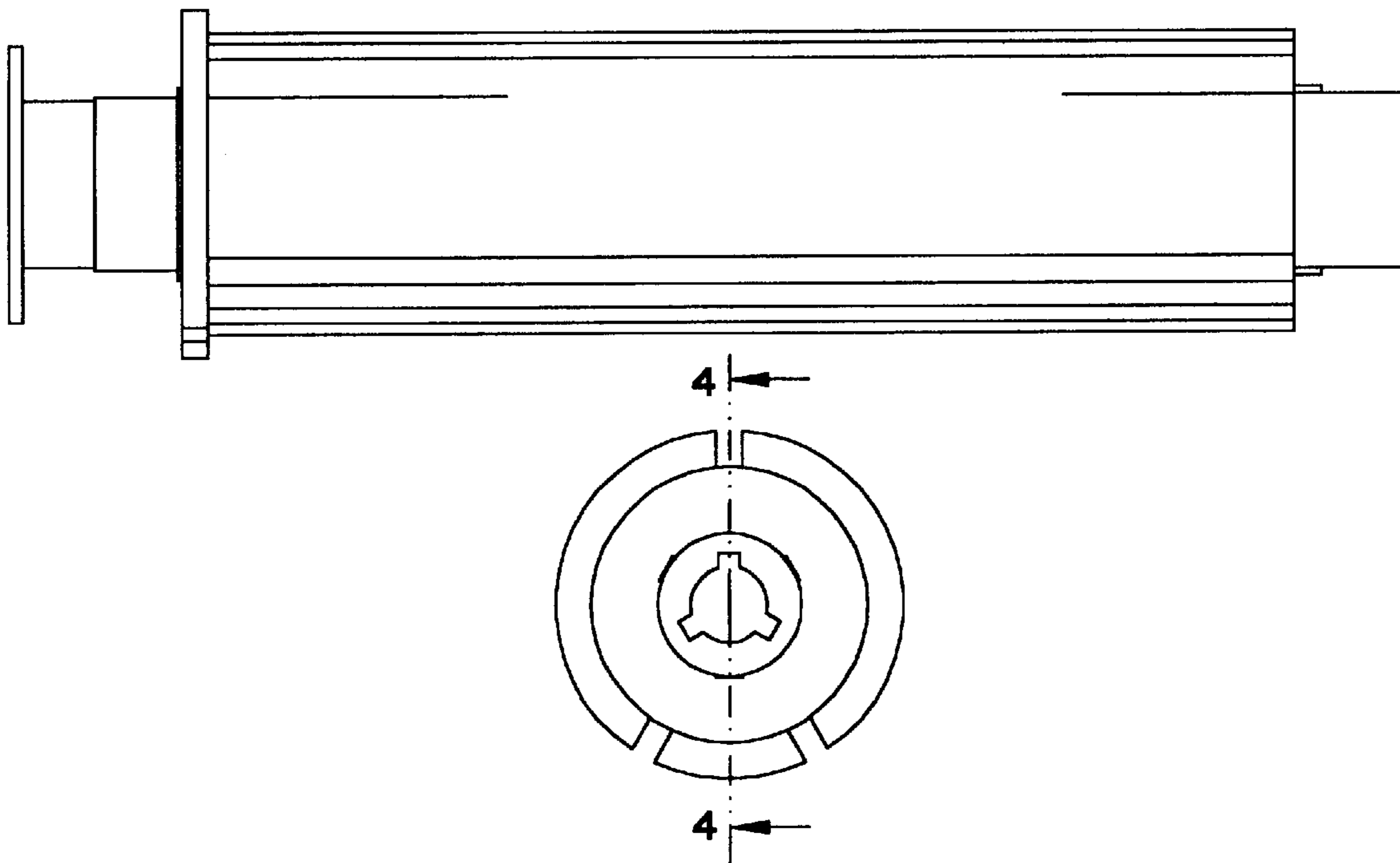
(57) **CLAIM**

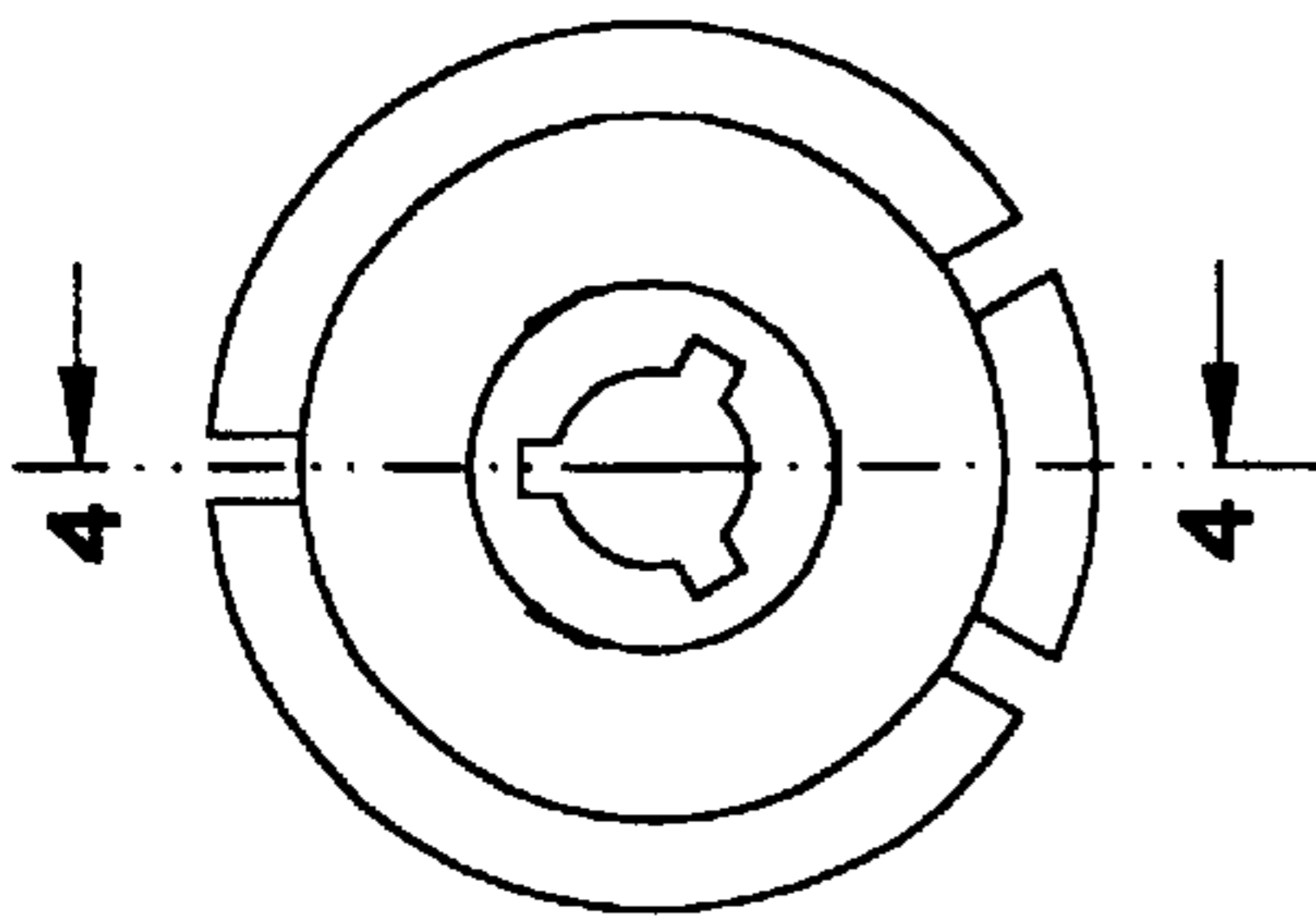
The ornamental design for a “drive hub assembly for a thermal transfer printer”, as shown and described.

**DESCRIPTION**

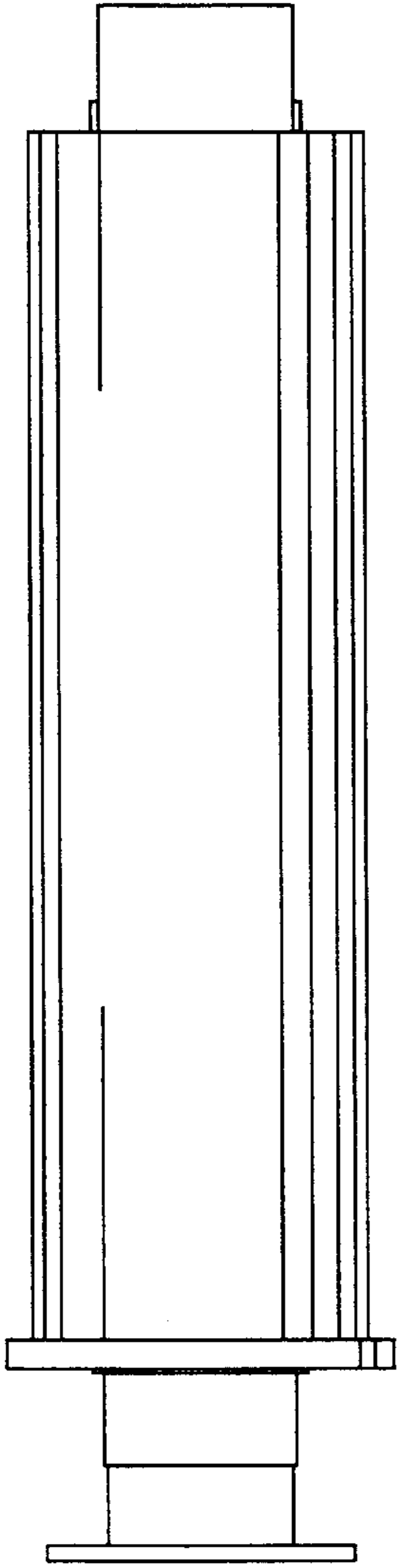
FIG. 1 is a front elevational view of a drive hub assembly for a thermal transfer printer showing my new design;  
 FIG. 2 is a left side elevational view;  
 FIG. 3 is a right side elevational view;  
 FIG. 4 is a cross section view taken along lines 4—4 in FIG. 2;  
 FIG. 5 is a front elevational view of the drive spindle shown separately for ease of illustration;  
 FIG. 6 is a left side elevational view;  
 FIG. 7 is a right side elevational view;  
 FIG. 8 is a cross section view taken along lines 8—8 in FIG. 6;  
 FIG. 9 is a front elevational view of the core shown separately for ease of illustration;  
 FIG. 10 is a left side elevational view;  
 FIG. 11 is a cross section view taken along lines 11—11 in FIG. 10;  
 FIG. 12 is a front elevational view of the drive hub shown separately for ease of illustration;  
 FIG. 13 is a left side elevational view;  
 FIG. 14 is a right side elevational view;  
 FIG. 15 is a cross section view taken along lines 15—15 in FIG. 13; and,  
 FIG. 16 is a bottom view of FIG. 14.

**1 Claim, 4 Drawing Sheets**

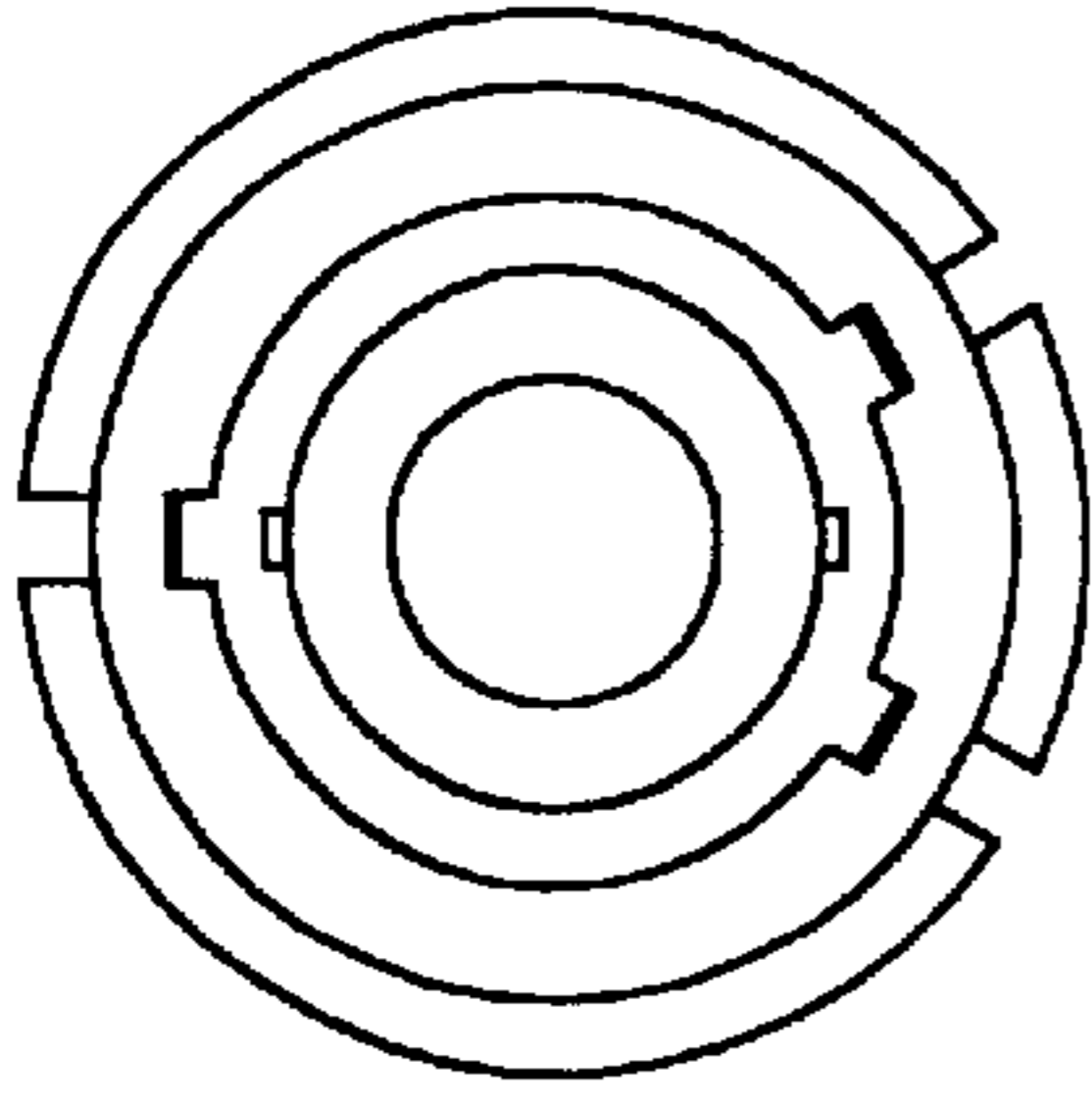




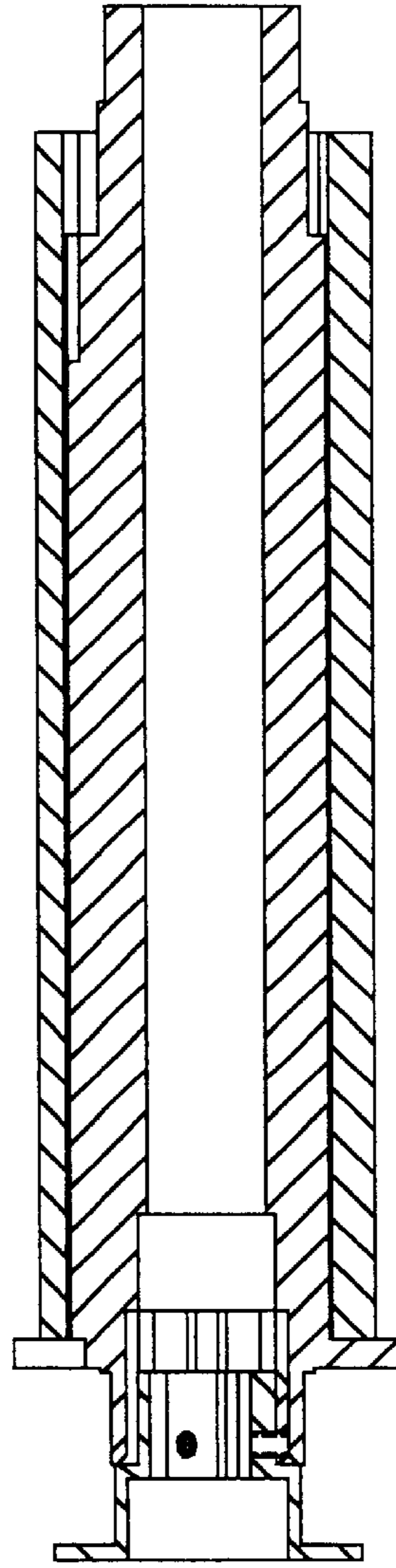
**FIG. 2**



**FIG. 1**



**FIG. 3**



**FIG. 4**

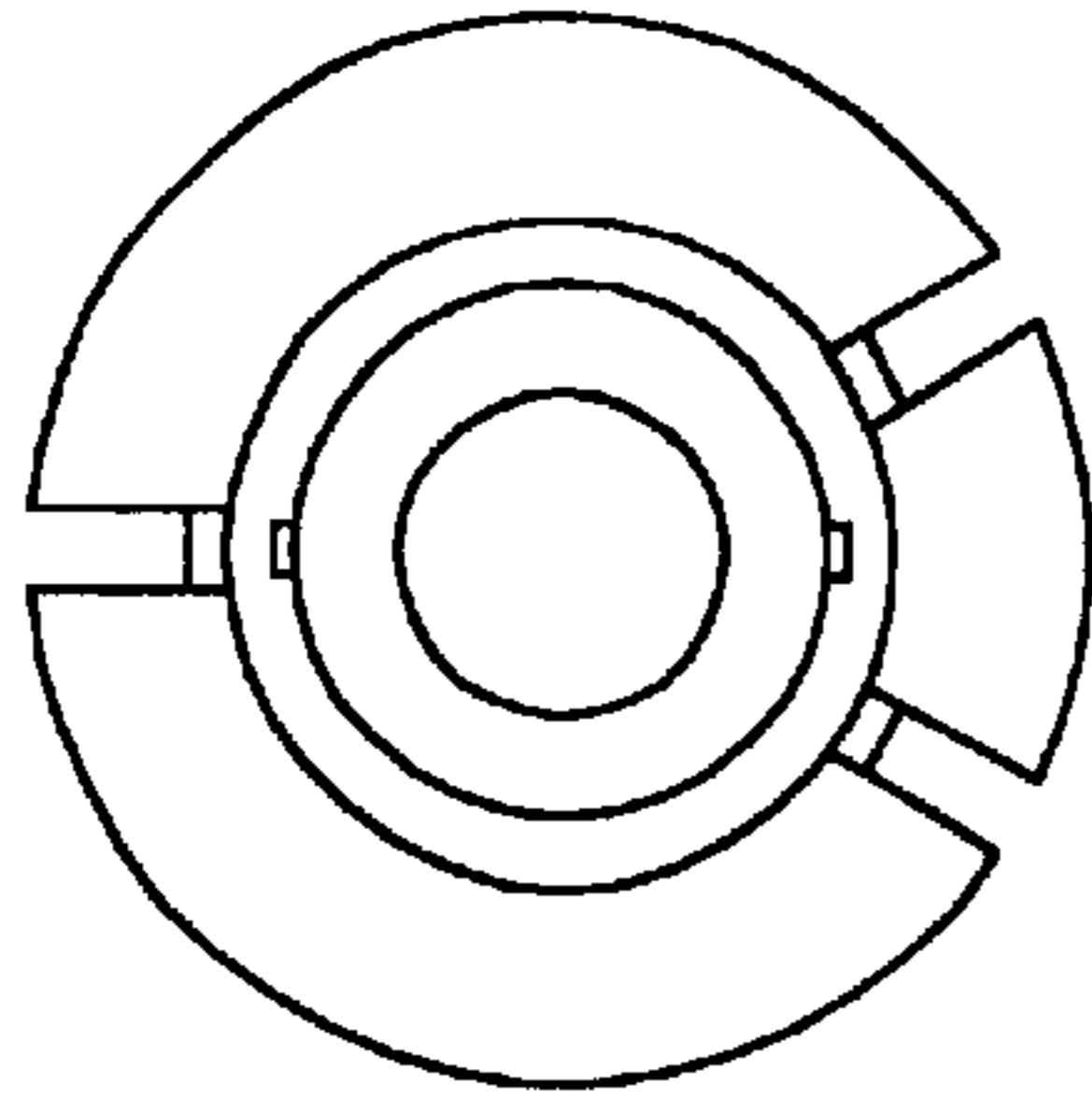


FIG. 7

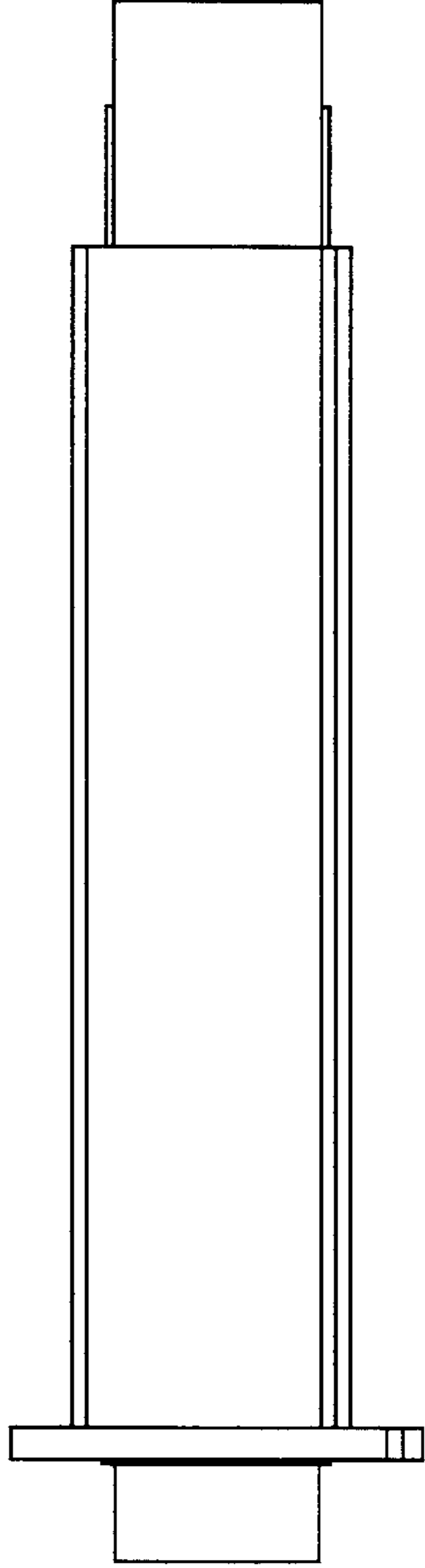


FIG. 5

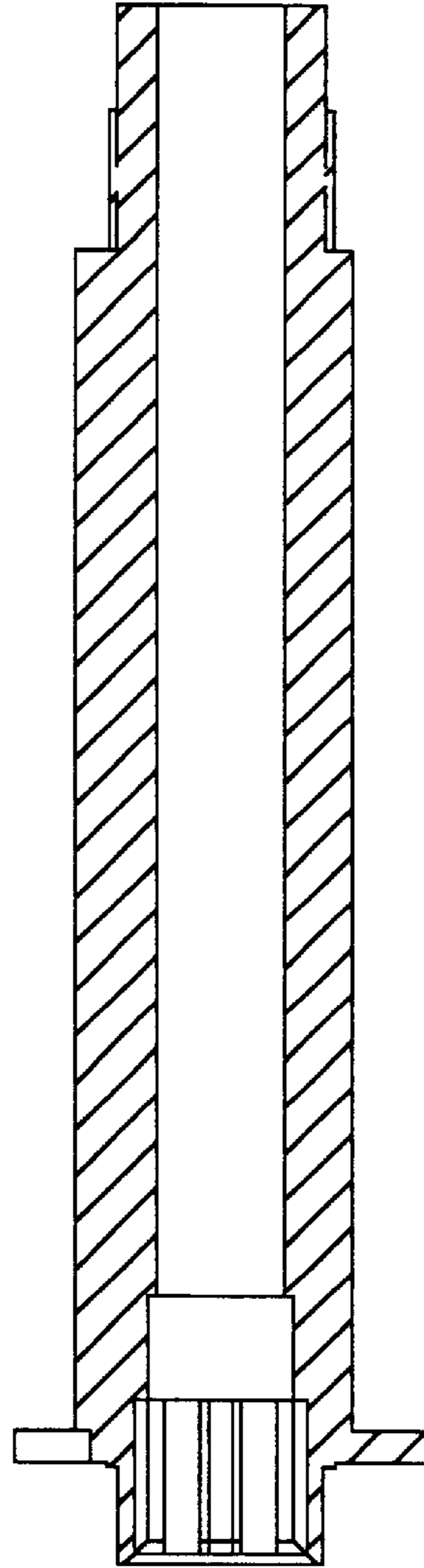


FIG. 8

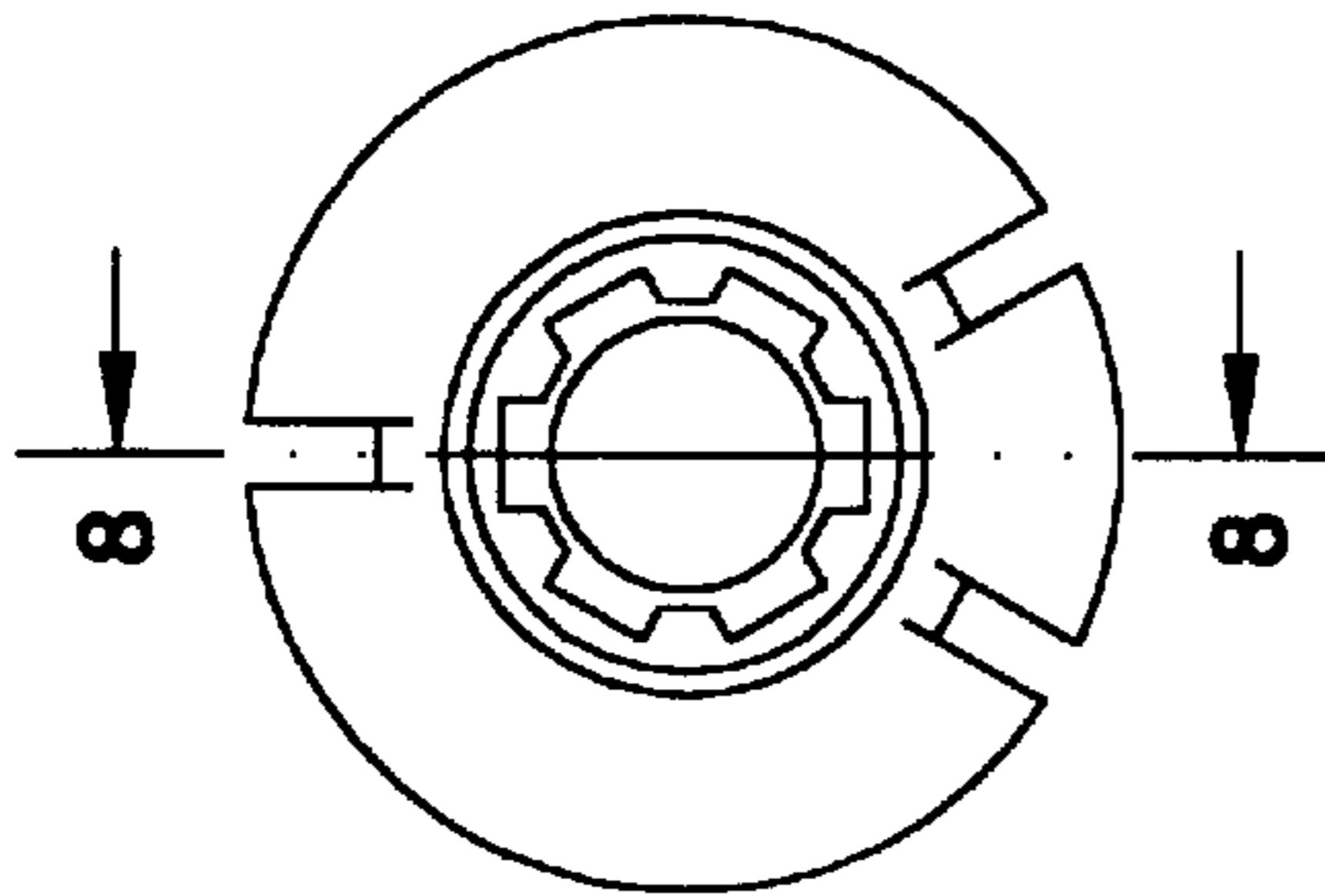
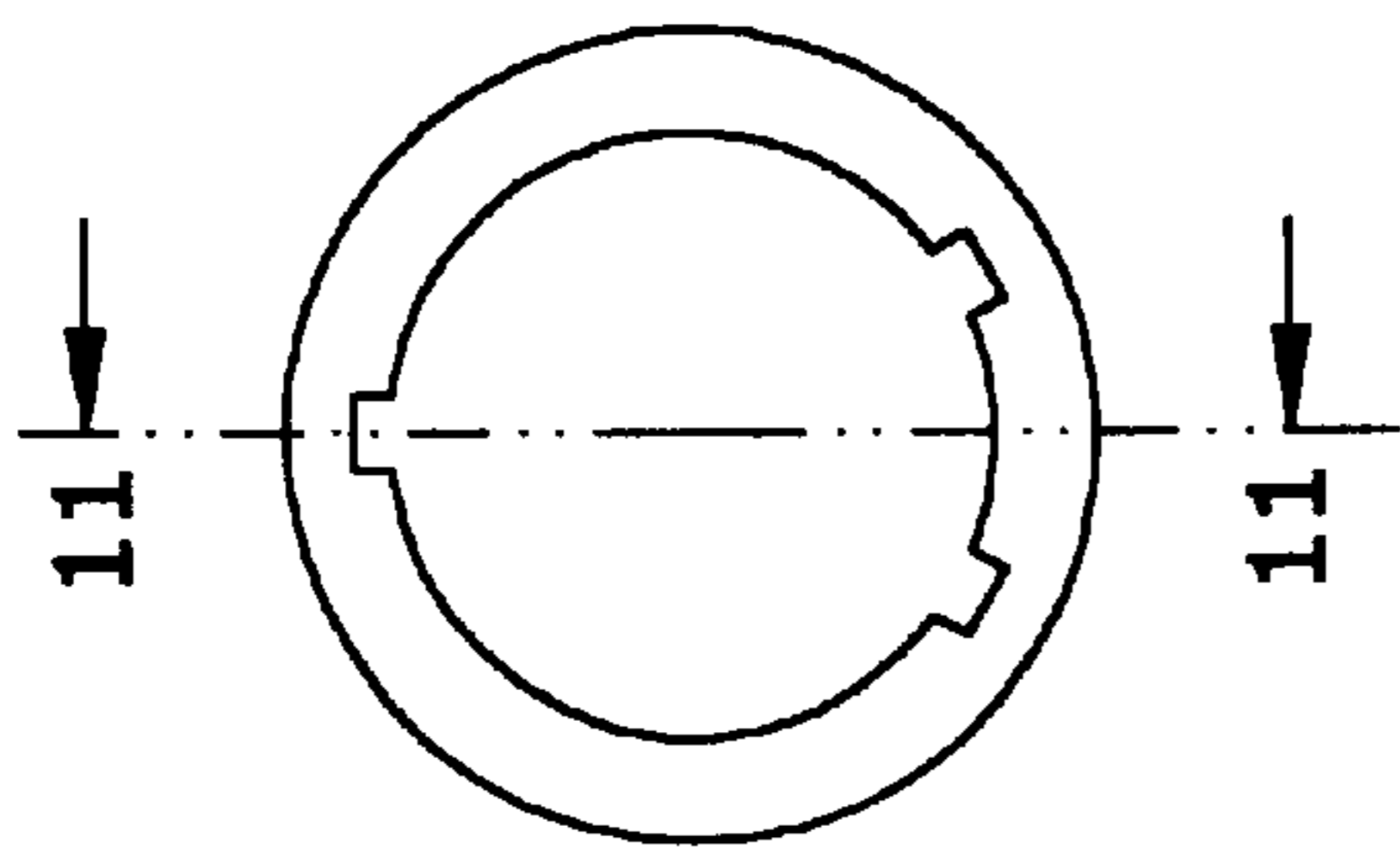
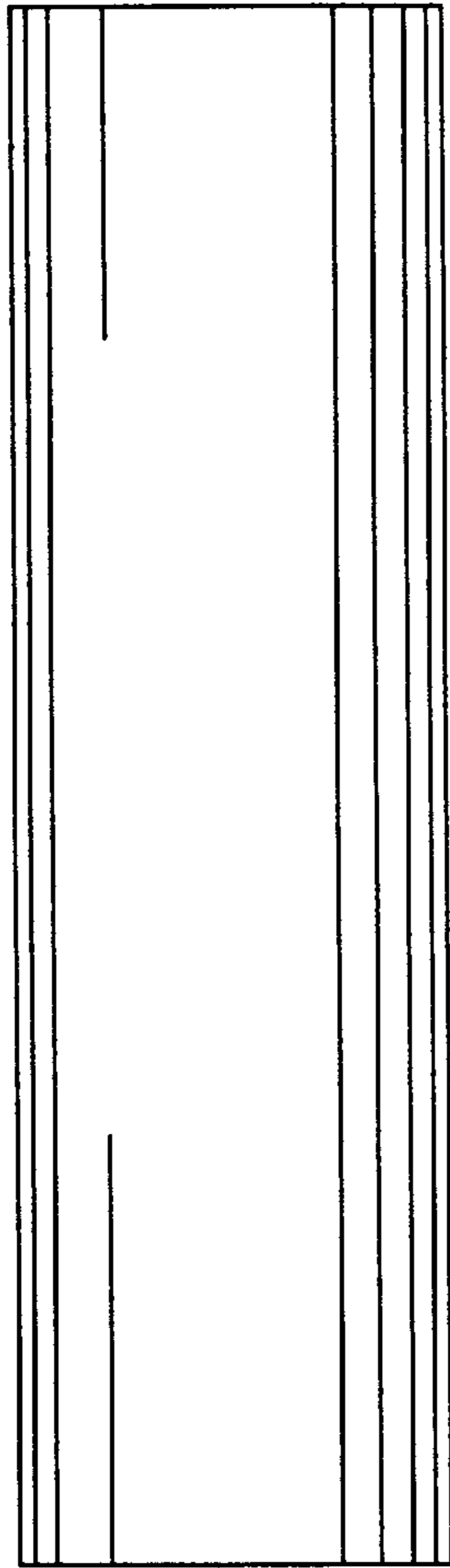


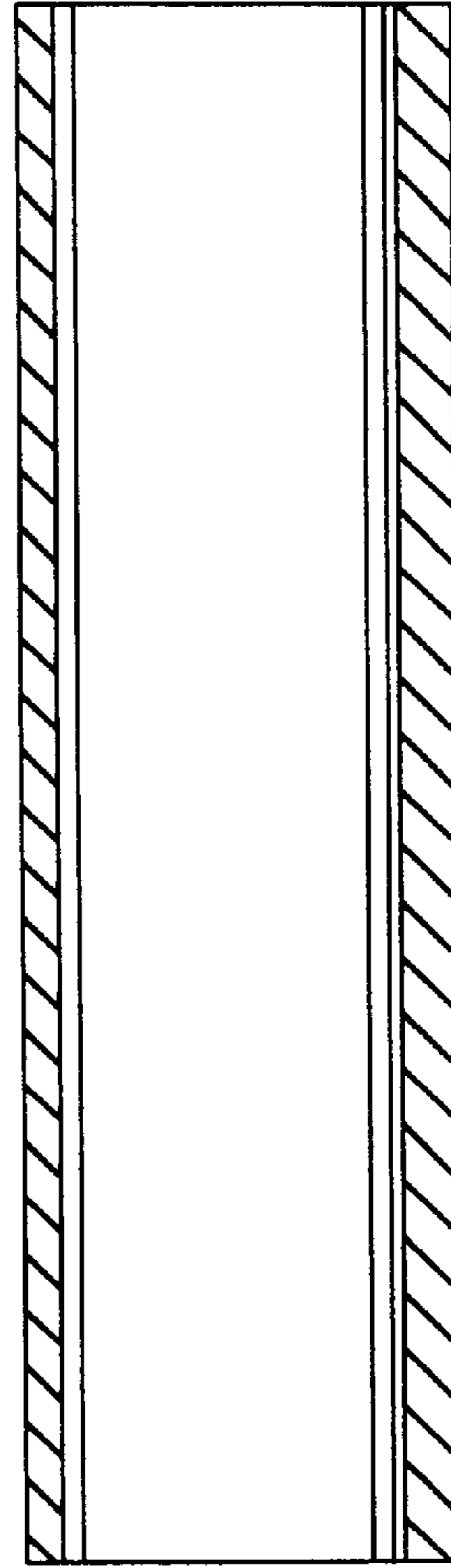
FIG. 6



**FIG. 10**



**FIG. 9**



**FIG. 11**

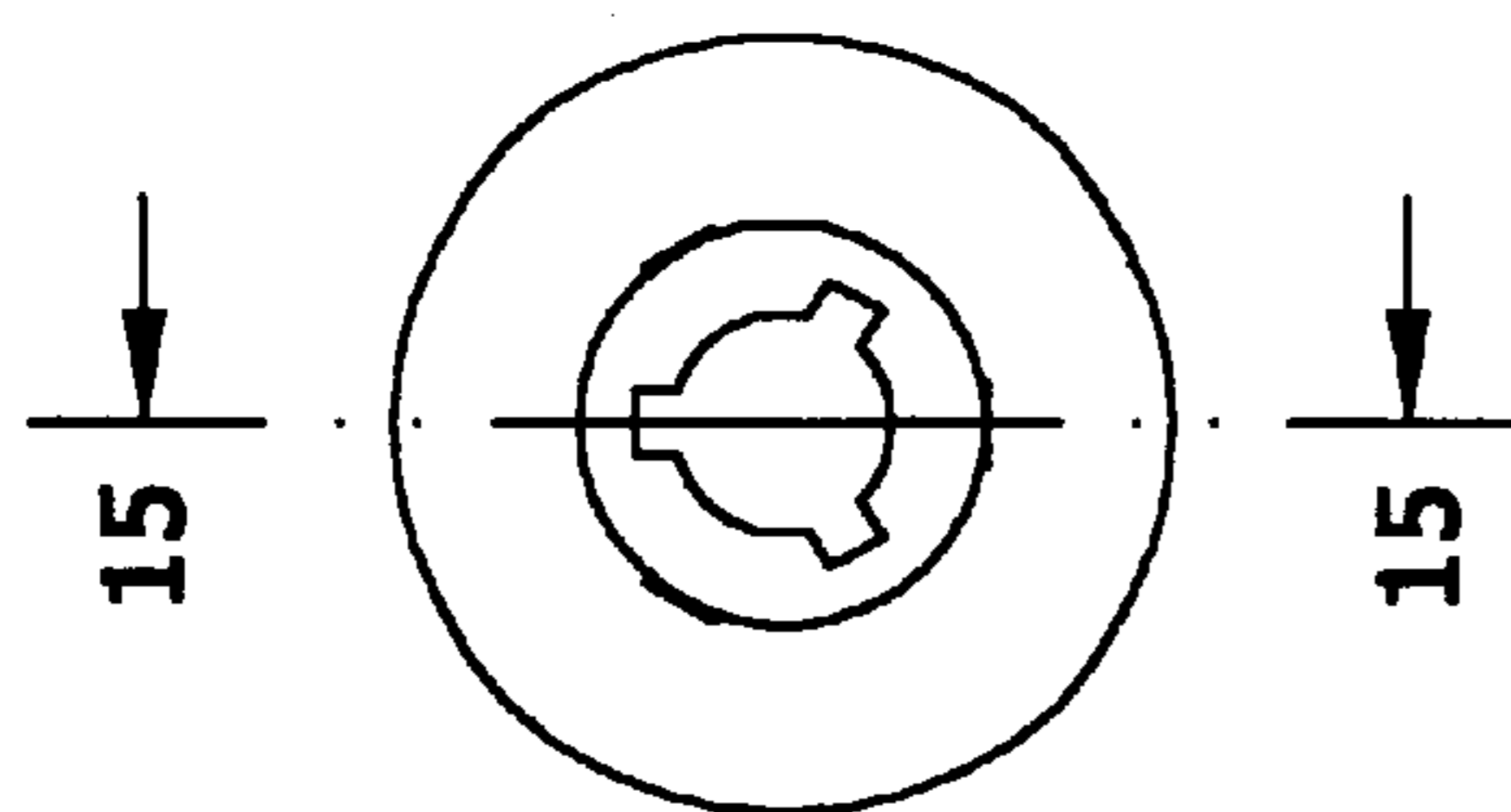


FIG. 13

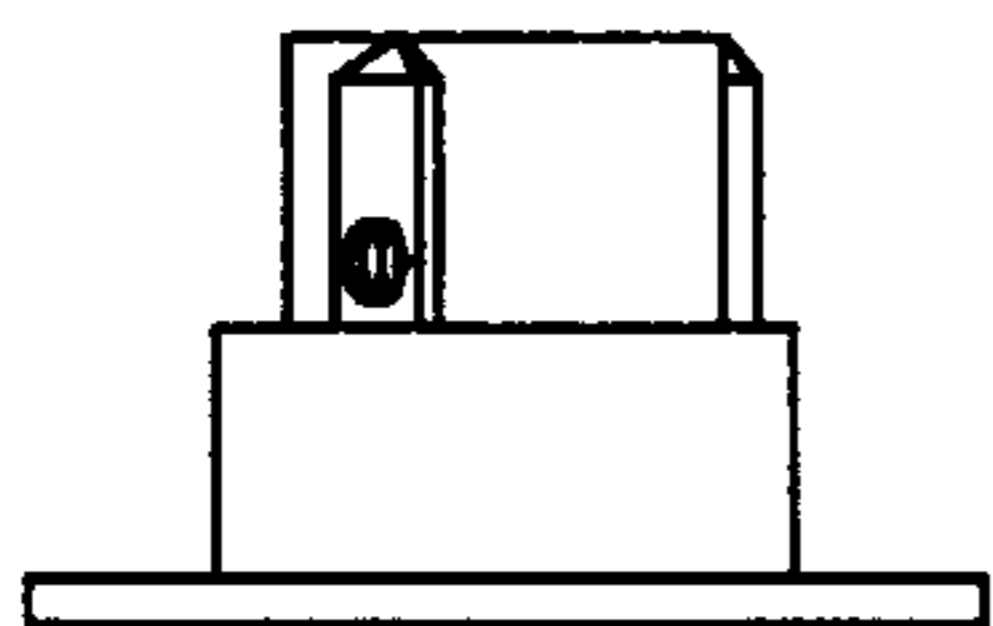


FIG. 12

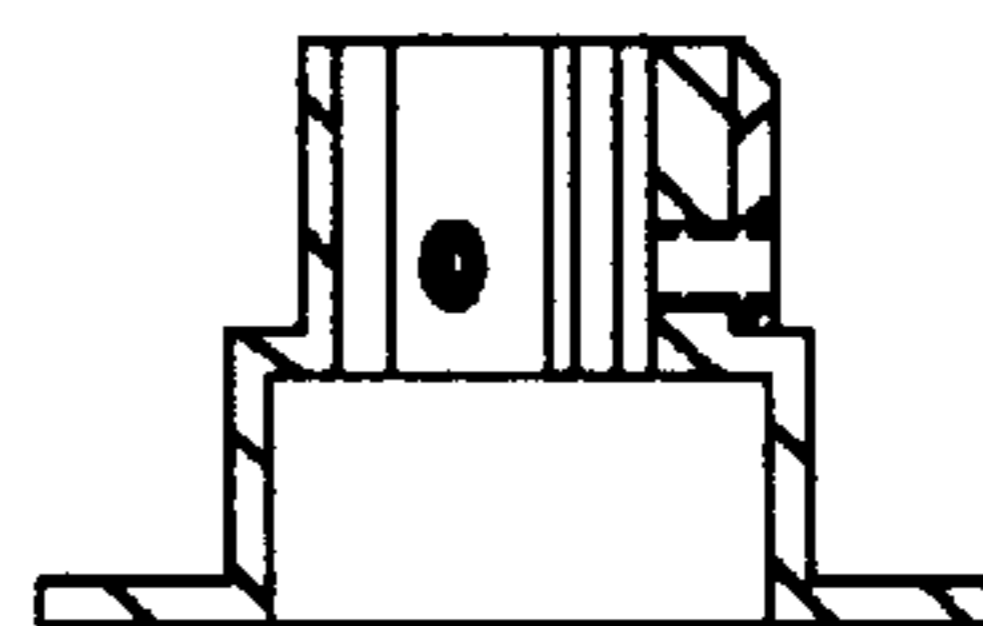


FIG. 15

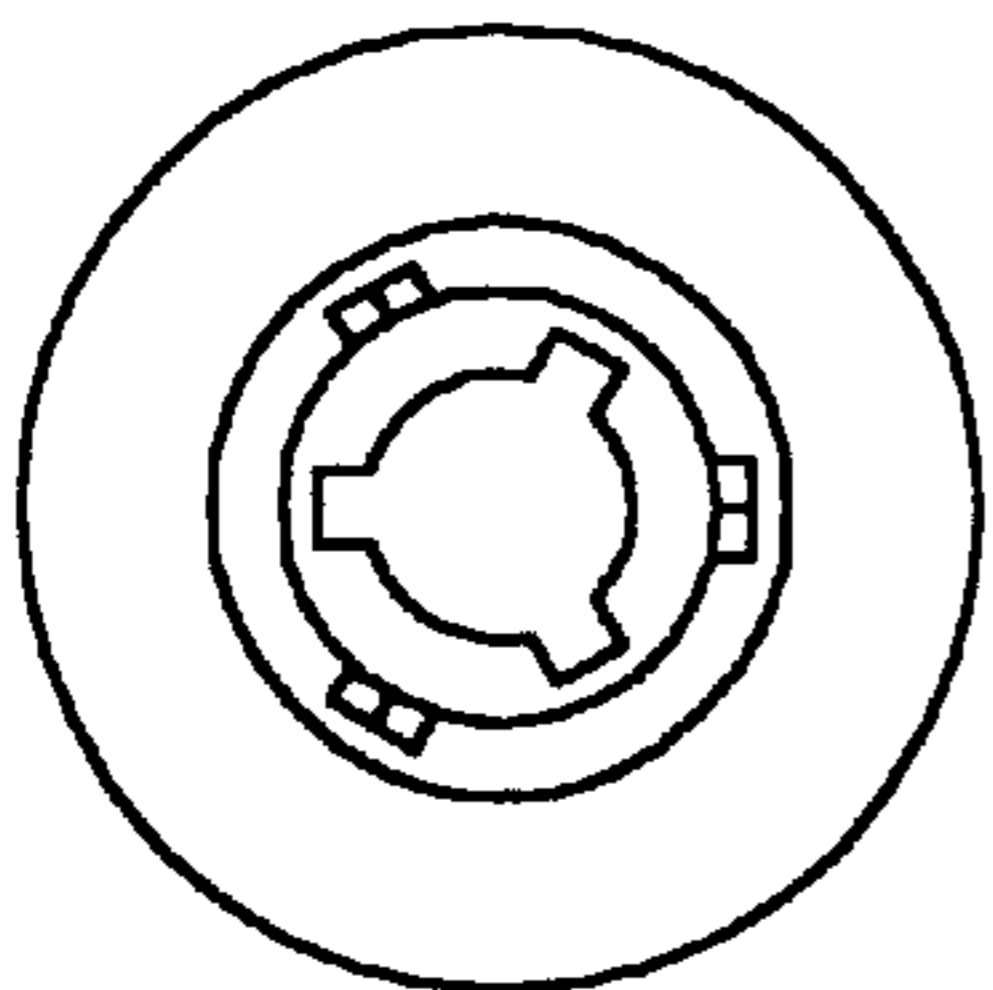


FIG. 14

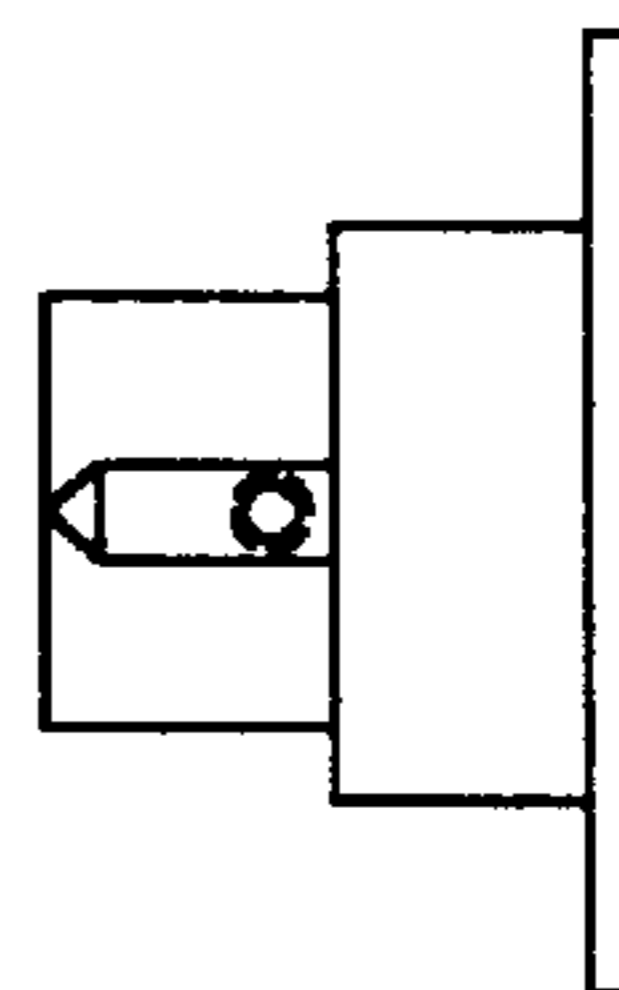


FIG. 16