



US00D478055S

(12) **United States Design Patent**
Jing et al.

(10) **Patent No.:** **US D478,055 S**

(45) **Date of Patent:** **** Aug. 5, 2003**

(54) **HEAT DISSIPATING FIN**

(75) Inventors: **Cheng-Du Jing**, Tu-Chen (TW); **Ching Huan Lin**, Tu-Chen (TW)

(73) Assignee: **Hon Hai Precision Ind. Co., Ltd.**,
Taipei Hsien (TW)

(**) Term: **14 Years**

(21) Appl. No.: **29/166,673**

(22) Filed: **Aug. 30, 2002**

(30) **Foreign Application Priority Data**

Aug. 8, 2002 (TW) 91304257

(51) **LOC (7) Cl.** **13-03**

(52) **U.S. Cl.** **D13/179**

(58) **Field of Search** D13/179; 165/80.3,
165/104.33, 121, 122, 146, 185; 174/16.3;
257/670, 675, 676, 706, 707, 718, 719,
721, 722; 361/695, 697, 699, 702, 704,
709, 514

(56) **References Cited**

U.S. PATENT DOCUMENTS

5,625,229 A * 4/1997 Kojima et al. 257/712

6,263,956 B1 * 7/2001 Tang et al. 165/80.3

6,324,061 B1 * 11/2001 Kinoshita et al. 361/709

6,357,514 B1 * 3/2002 Sasaki et al. 165/80.3

6,382,307 B1 * 5/2002 Wang et al. 165/80.3

6,501,655 B1 * 12/2002 Lee et al. 361/703

* cited by examiner

Primary Examiner—Mitchell Siegel

Assistant Examiner—Selina Sikder

(74) *Attorney, Agent, or Firm*—Wei Te Chung

(57) **CLAIM**

The ornamental design for a heat dissipating fin, as shown and described.

DESCRIPTION

FIG. 1 is a perspective view of a heat dissipating fin of our new design;

FIG. 2 is a front elevational view thereof;

FIG. 3 is a rear elevational view thereof;

FIG. 4 is a left side elevational view thereof;

FIG. 5 is a right side elevational view thereof;

FIG. 6 is a top plan view thereof;

FIG. 7 is a bottom plan view thereof; and,

FIG. 8 is a perspective view of the heat dissipating fin of FIG. 1 being mounted to three heat pipes attached on a base. The broken lines are shown for illustrative purpose only and form no part of the claimed design.

1 Claim, 6 Drawing Sheets

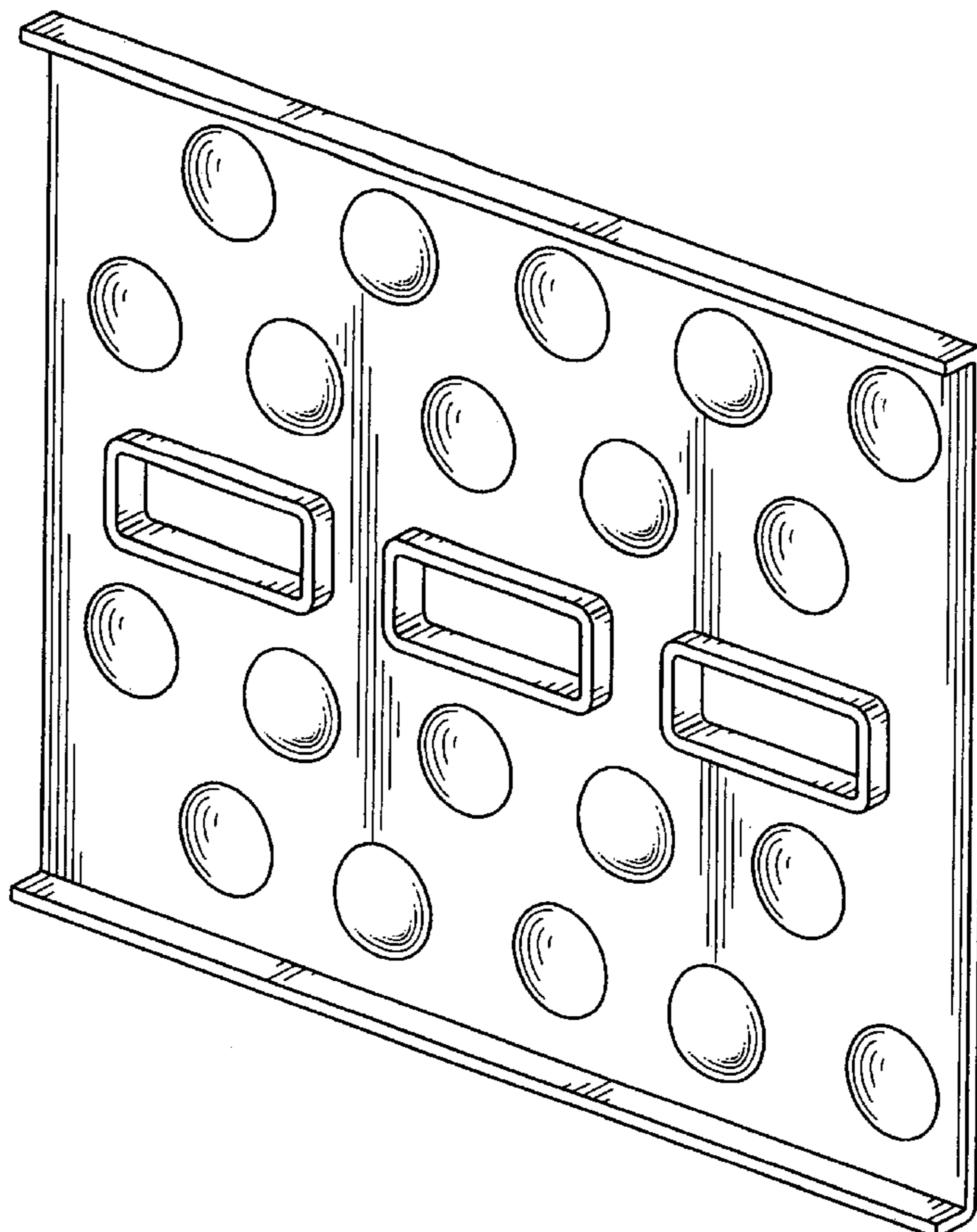

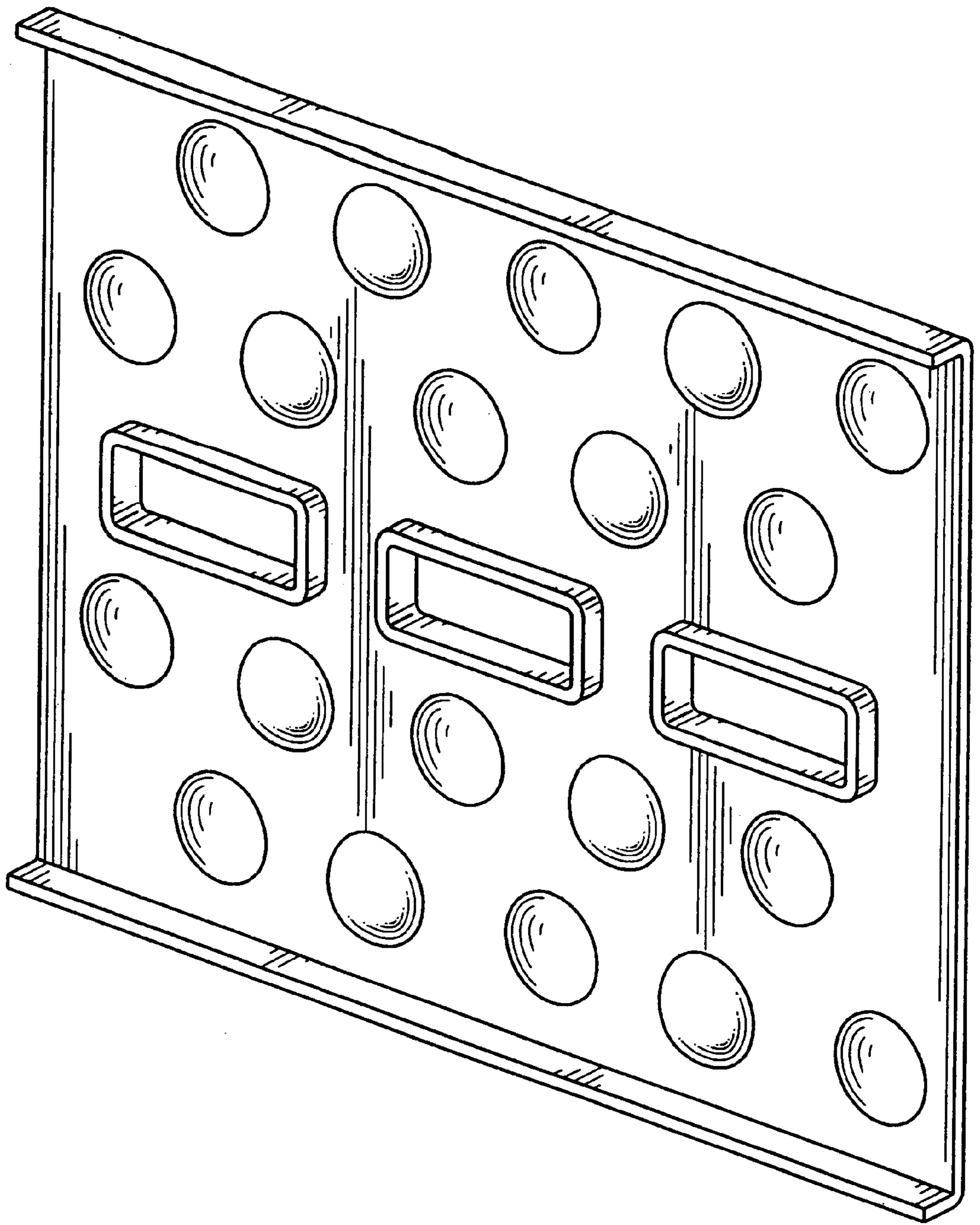

FIG. 1

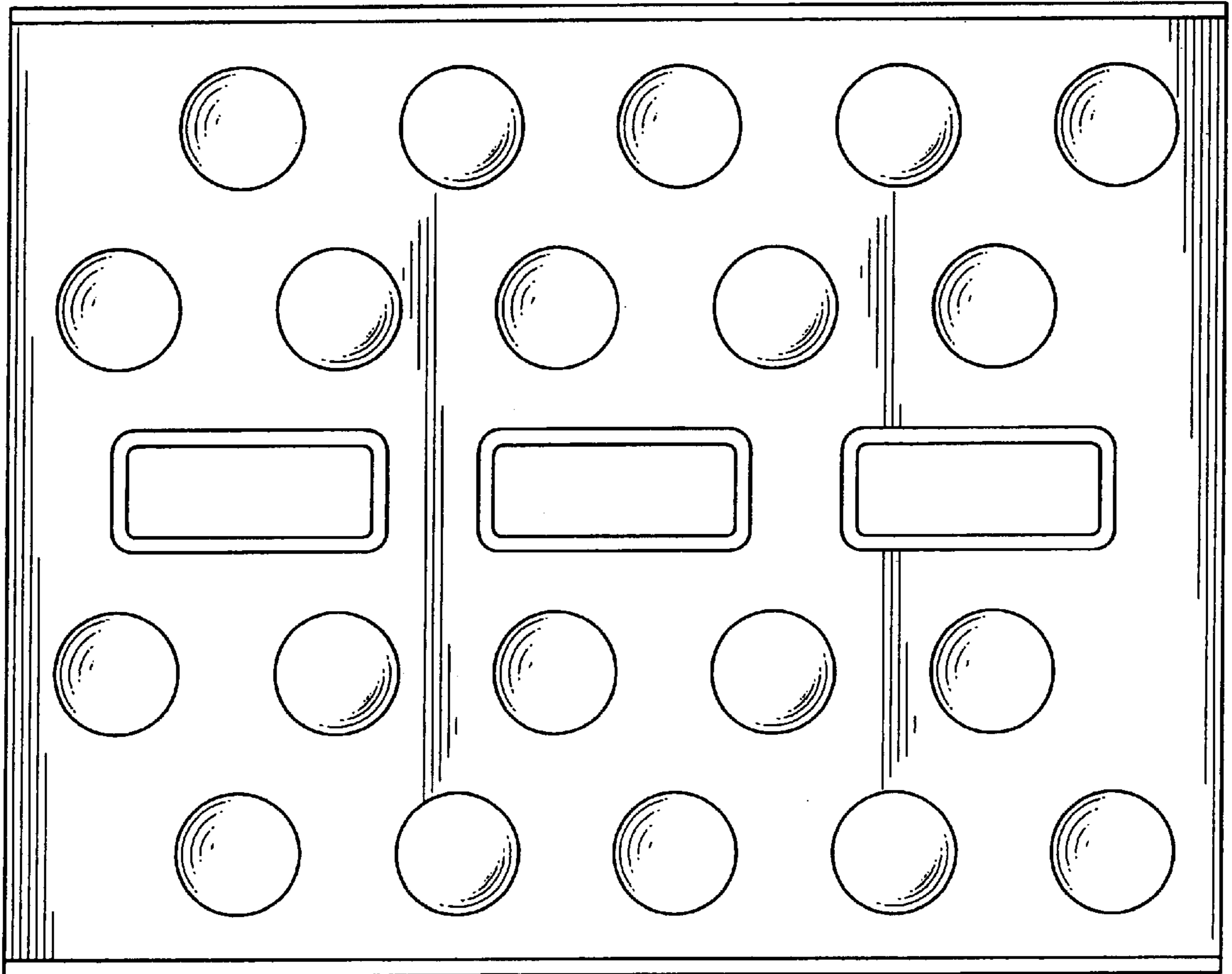

FIG. 2

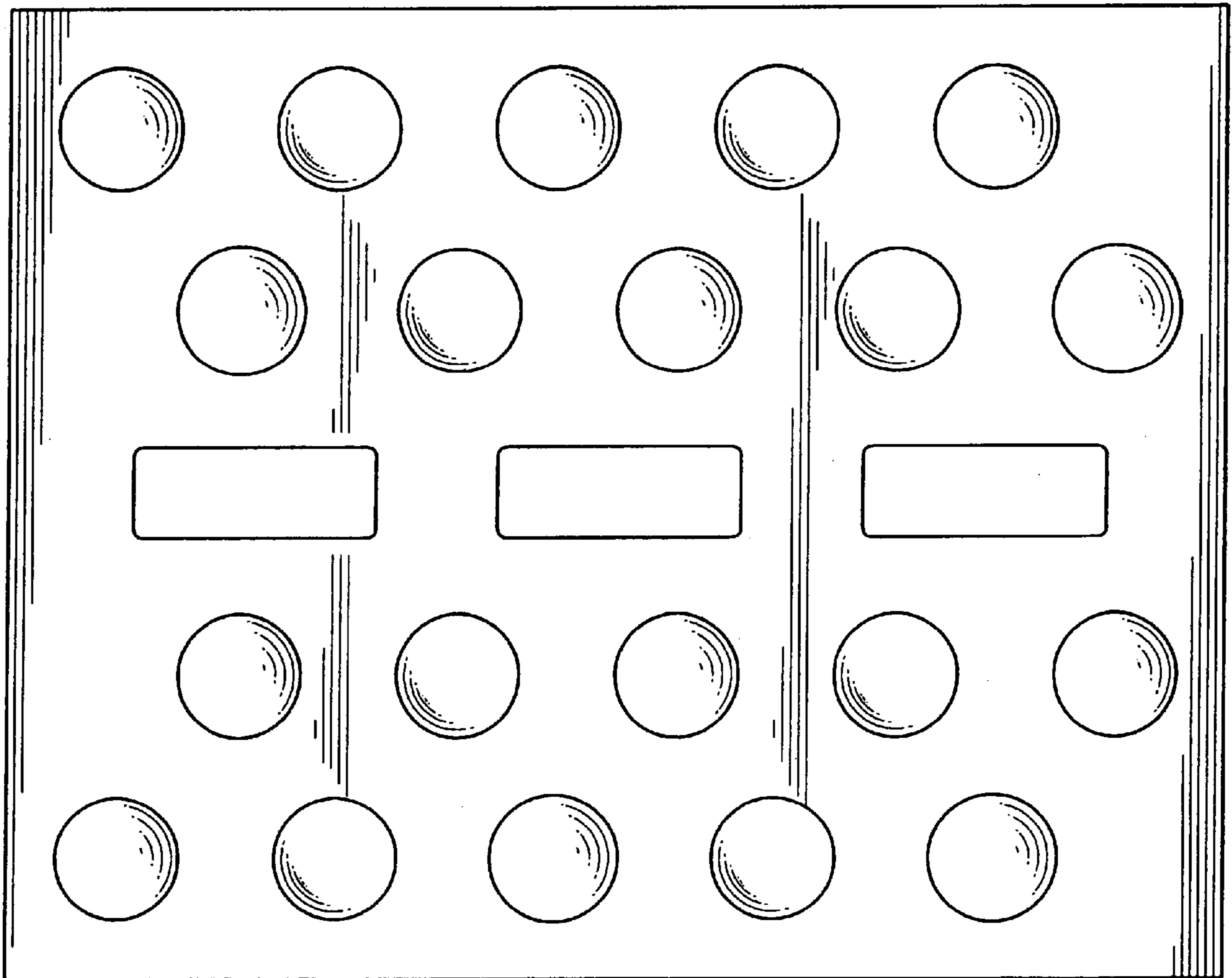

FIG. 3

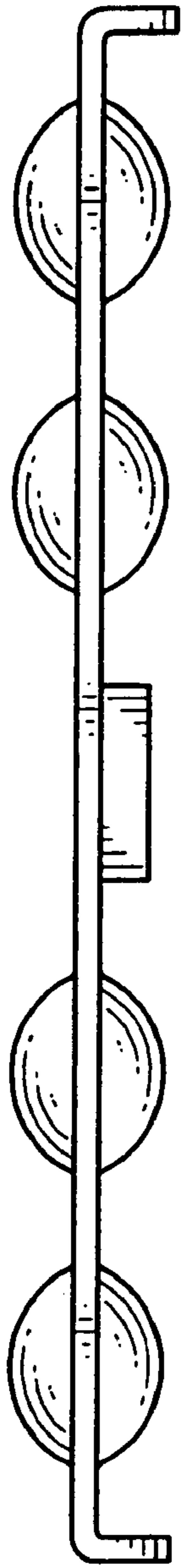

FIG. 4

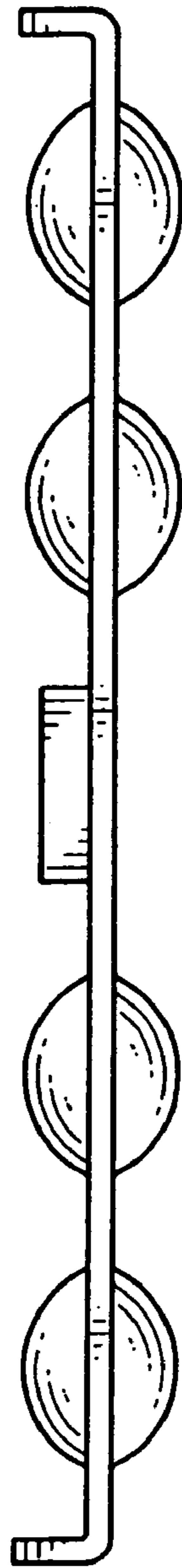

FIG. 5



FIG. 6



FIG. 7

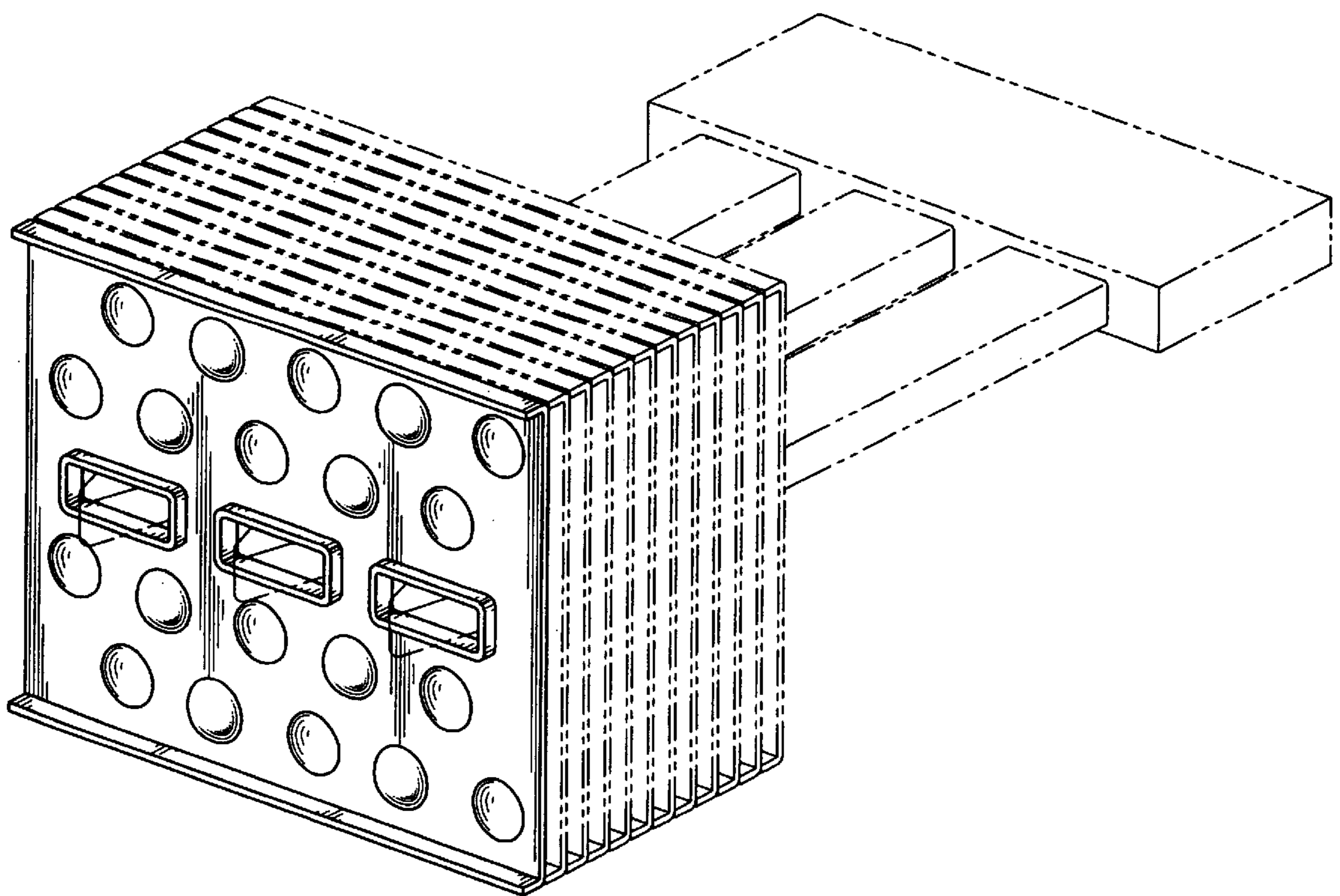

FIG. 8