



US00D478049S

(12) **United States Design Patent**
Garver

(10) **Patent No.:** **US D478,049 S**

(45) **Date of Patent:** **** Aug. 5, 2003**

(54) **WATERPROOF PLUG**

(75) **Inventor:** **Scott A. Garver**, Fort Wayne, IN (US)

(73) **Assignee:** **Lyall Technologies, Inc.**, Albion, IN (US)

(**) **Term:** **14 Years**

(21) **Appl. No.:** **29/163,821**

(22) **Filed:** **Jul. 12, 2002**

(51) **LOC (7) Cl.** **13-03**

(52) **U.S. Cl.** **D13/147**

(58) **Field of Search** D13/146, 147,
D13/154, 138.1; 439/660, 680, 358, 352,
386

(56) **References Cited**

U.S. PATENT DOCUMENTS

D99,787 S	*	5/1936	Gilbert	D13/138.1 X
2,179,197 A	*	11/1939	Raymond	D13/138.1 X
D227,370 S	*	6/1973	Ely	D13/138.1 X
D243,244 S	*	2/1977	Creamer	D13/138.1
4,674,814 A	*	6/1987	Hoshino et al.	439/586
4,884,978 A	*	12/1989	Inaba et al.	439/352
D384,643 S	*	10/1997	Nierlich et al.	D13/147
D463,370 S	*	9/2002	Chen	D13/147

D463,776 S	*	10/2002	Chen	D13/147
2001/0021603 A1	*	9/2001	Chen	439/358
2002/0119693 A1	*	8/2002	Chen	439/358

* cited by examiner

Primary Examiner—Joel Sincavage

(74) *Attorney, Agent, or Firm*—Taylor & Aust, P.C.

(57) **CLAIM**

The ornamental design for a waterproof plug, as shown and described.

DESCRIPTION

FIG. 1 is a perspective view of a waterproof plug showing my new design, the portion in phantom lines illustrating a variable number of electrical terminals;

FIG. 2 is a side view thereof, the opposite side being substantially identical;

FIG. 3 is a top view thereof;

FIG. 4 is a bottom view thereof;

FIG. 5 is an end view thereof; and,

FIG. 6 is an opposite end view thereof.

The broken lines throughout the drawing are included for the purpose of illustrating environmental structure only and form no part of the claimed design.

1 Claim, 2 Drawing Sheets

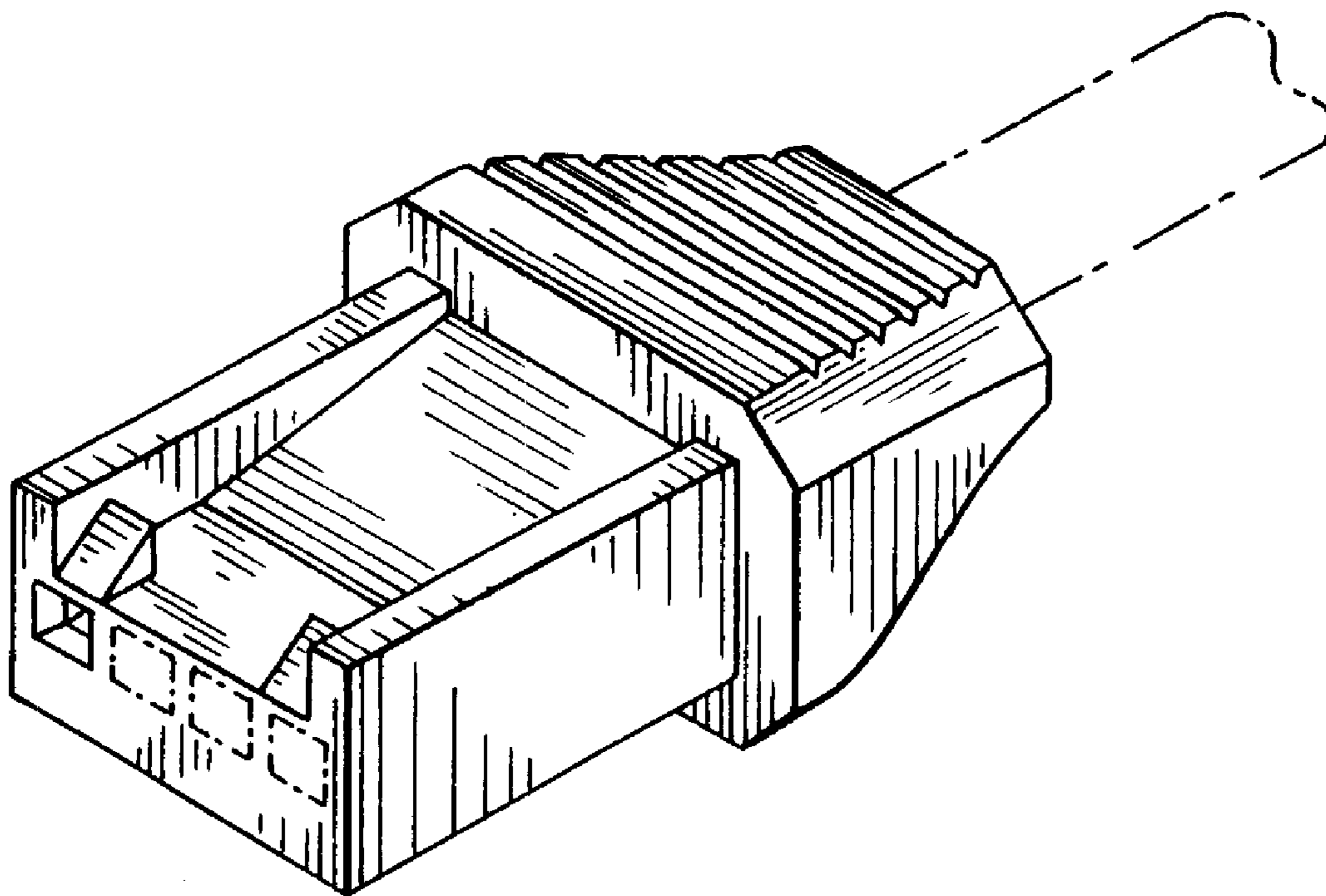

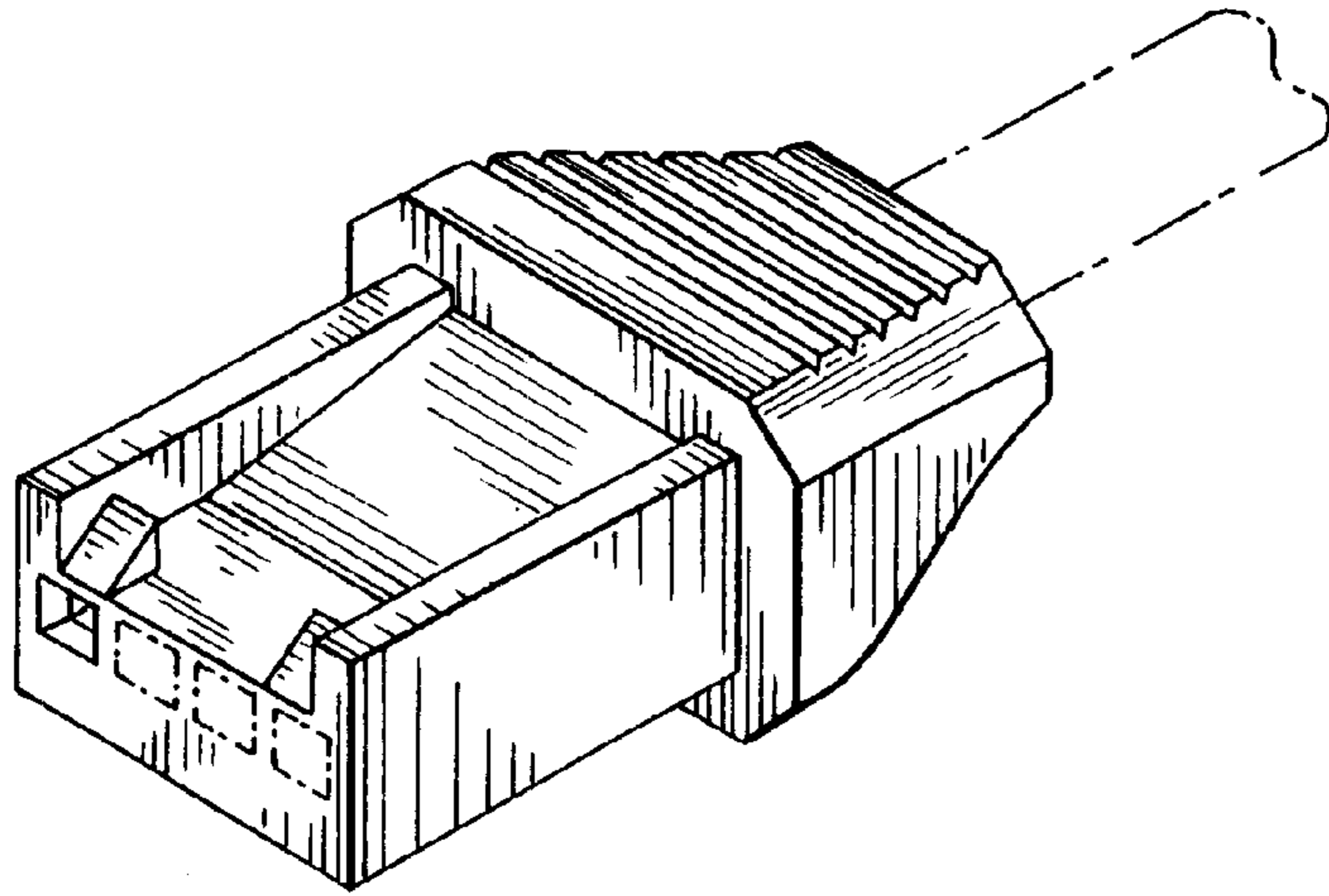

Fig. 1

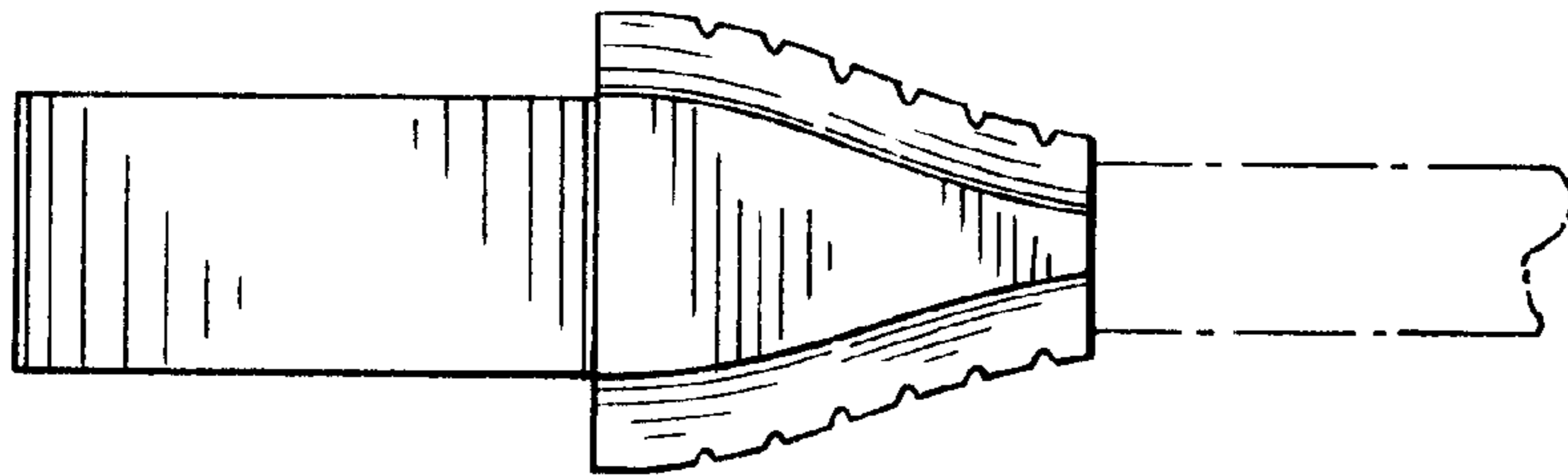

Fig. 2

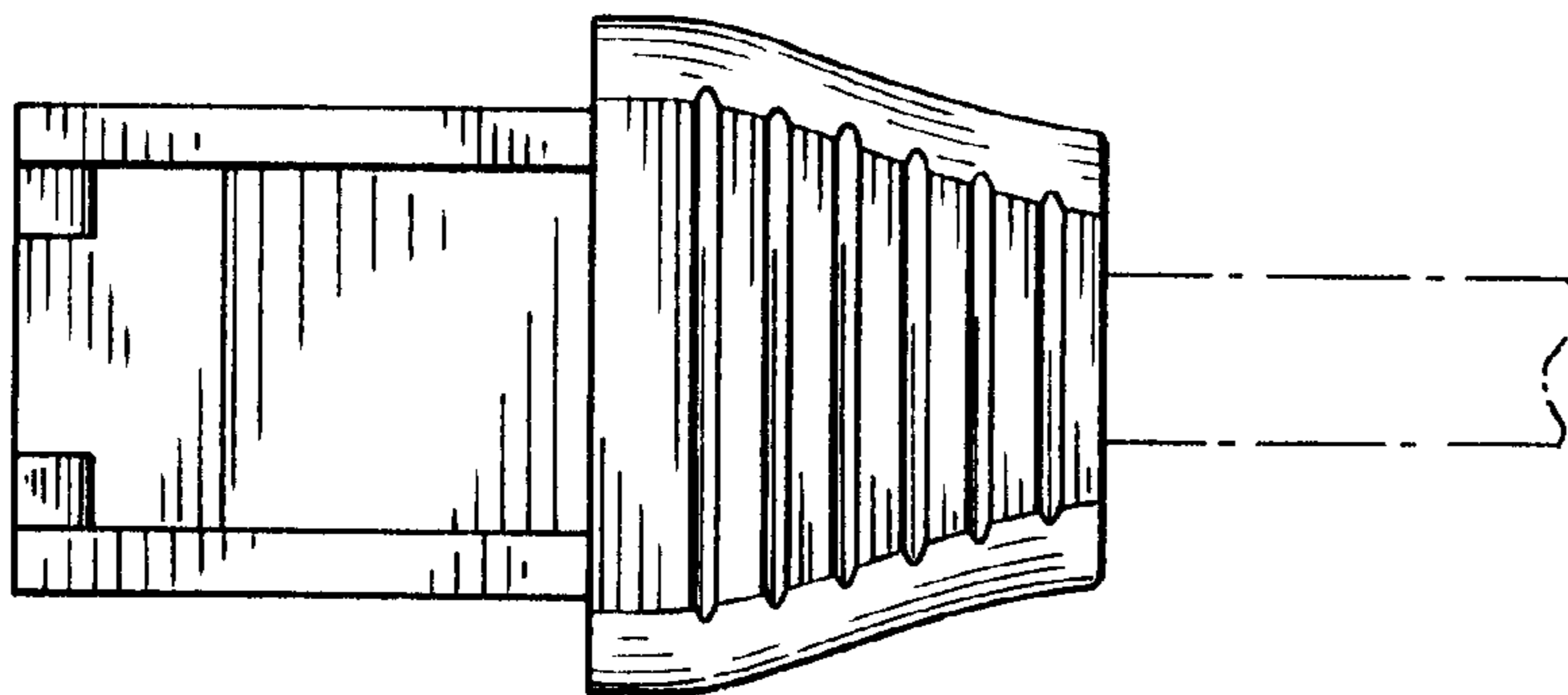

Fig. 3

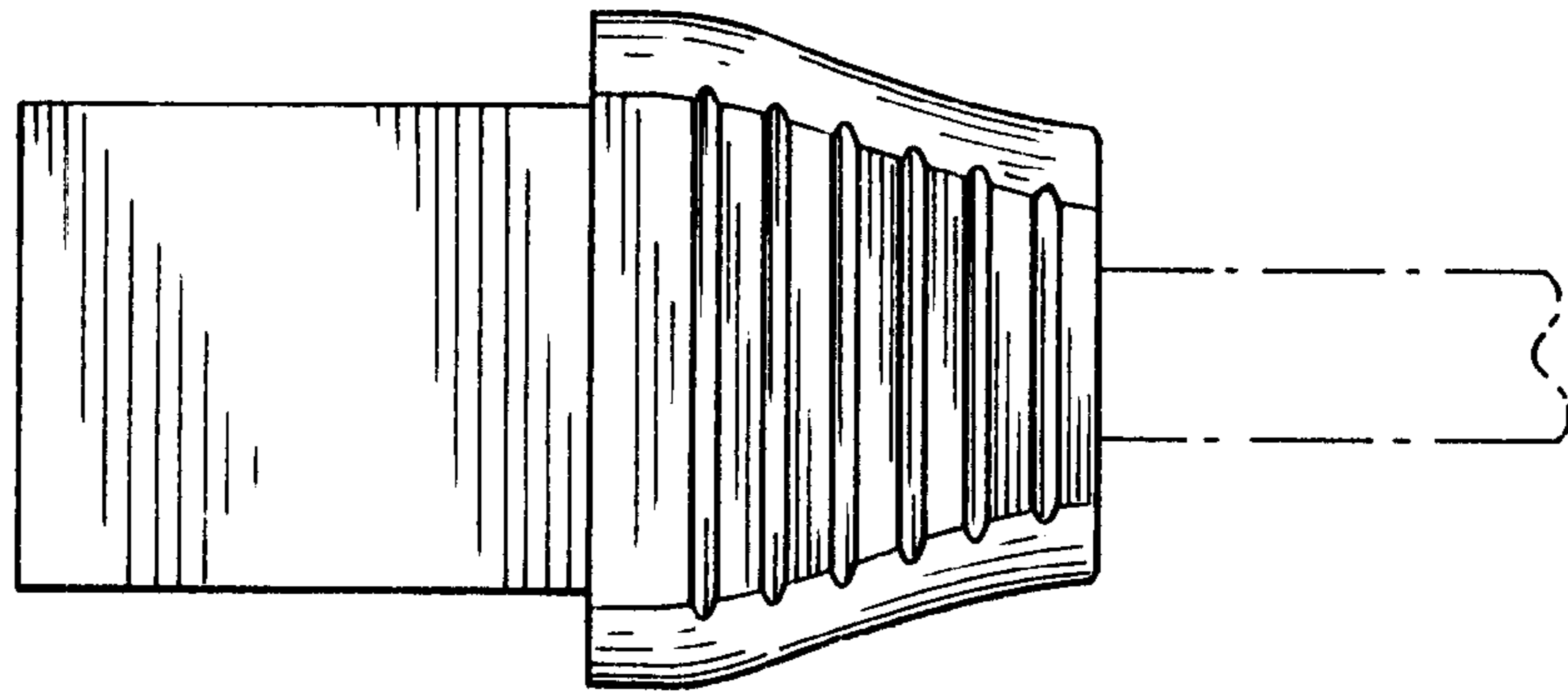

Fig. 4

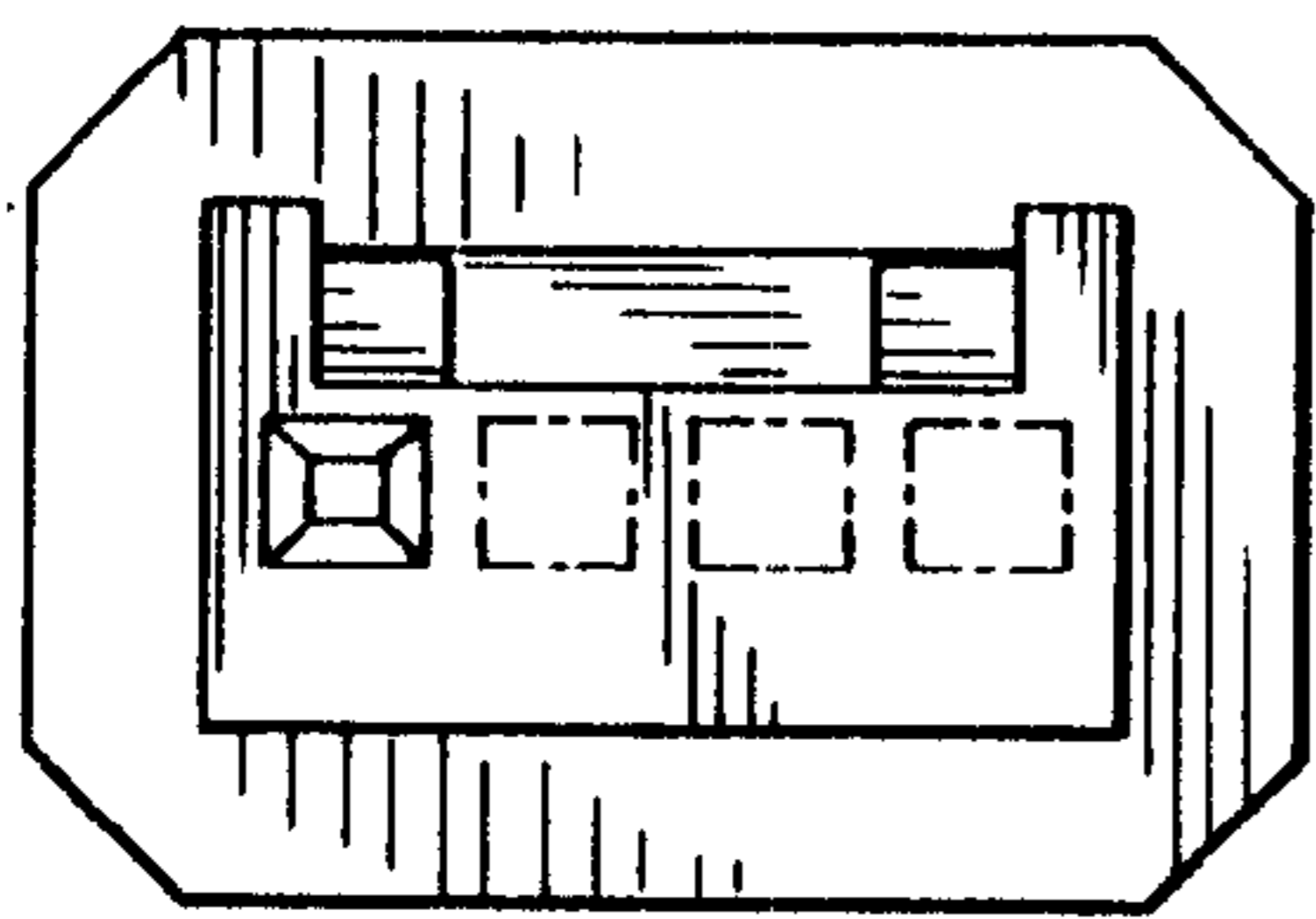

Fig. 5

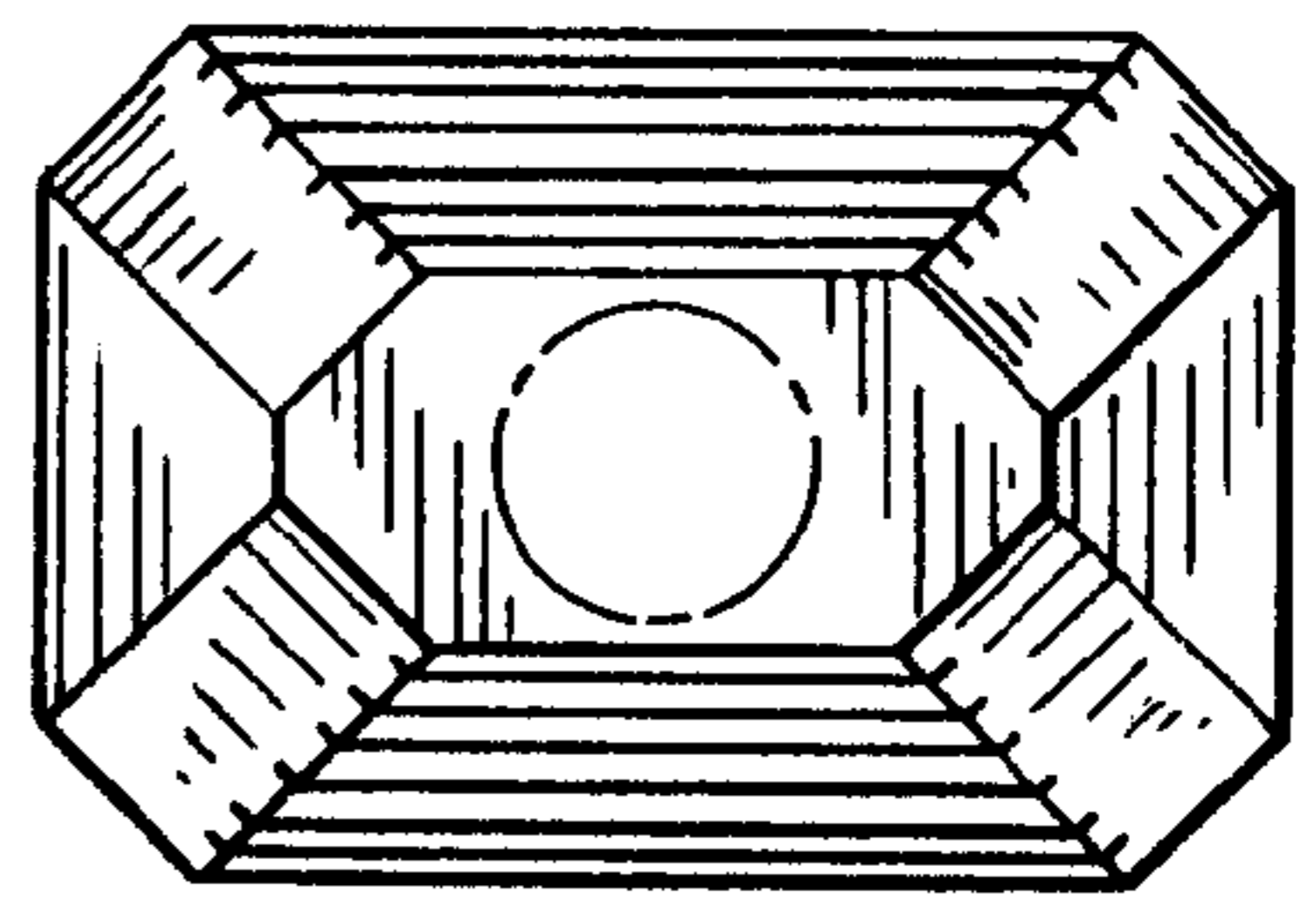

Fig. 6