



US00D477811S

(12) **United States Design Patent**
Niwa et al.

(10) **Patent No.:** **US D477,811 S**

(45) **Date of Patent:** **** Jul. 29, 2003**

(54) **BATTERY PACK**

(75) **Inventors:** **Norifumi Niwa, Anjo (JP); Kazuma Oshima, Anjo (JP); Shinsuke Okuda, Anjo (JP)**

(73) **Assignee:** **Makita Corporation, Aichi-ken (JP)**

(**) **Term:** **14 Years**

(21) **Appl. No.:** **29/163,522**

(22) **Filed:** **Jul. 9, 2002**

(30) **Foreign Application Priority Data**

Jan. 9, 2002 (JP) 2002-003854
Jan. 9, 2002 (JP) 2002-003855

(51) **LOC (7) Cl.** **13-02**

(52) **U.S. Cl.** **D13/103**

(58) **Field of Search** D13/103; 429/96-100,
429/159, 163, 176

(56) **References Cited**

U.S. PATENT DOCUMENTS

D304,026 S * 10/1989 Goodner et al. D13/103
D379,795 S * 6/1997 Pitzen et al. D13/103
5,881,823 A * 3/1999 Kabatnik et al. 173/217
D413,564 S * 9/1999 Hershberger et al. D13/103
D415,100 S * 10/1999 Buck D13/103
5,977,746 A * 11/1999 Hershberger et al. 429/99 X

6,127,063 A * 10/2000 Kowalsky et al. 429/100
D436,917 S 1/2001 Hayakawa et al.
6,346,793 B1 * 2/2002 Shibata et al. 429/97 X
6,350,149 B1 * 2/2002 Nakane 439/500
D456,002 S 4/2002 Kato et al.
6,501,197 B1 * 12/2002 Cornog et al. 307/150

FOREIGN PATENT DOCUMENTS

JP 2001135290 * 5/2001 H01M/2/10
JP 2001155700 * 6/2001 H01M/2/10

* cited by examiner

Primary Examiner—Joel Sincavage

(74) *Attorney, Agent, or Firm*—Dennison, Schultz & Dougherty

(57) **CLAIM**

The ornamental design for a battery pack, as shown and described.

DESCRIPTION

FIG. 1 is a perspective view of a battery pack showing our new design.

FIG. 2 is a front elevation view thereof;

FIG. 3 is a rear elevation view thereof;

FIG. 4 is a left side elevation view thereof;

FIG. 5 is a right side elevation view thereof;

FIG. 6 is a top plan view thereof; and,

FIG. 7 is a bottom view thereof.

1 Claim, 4 Drawing Sheets

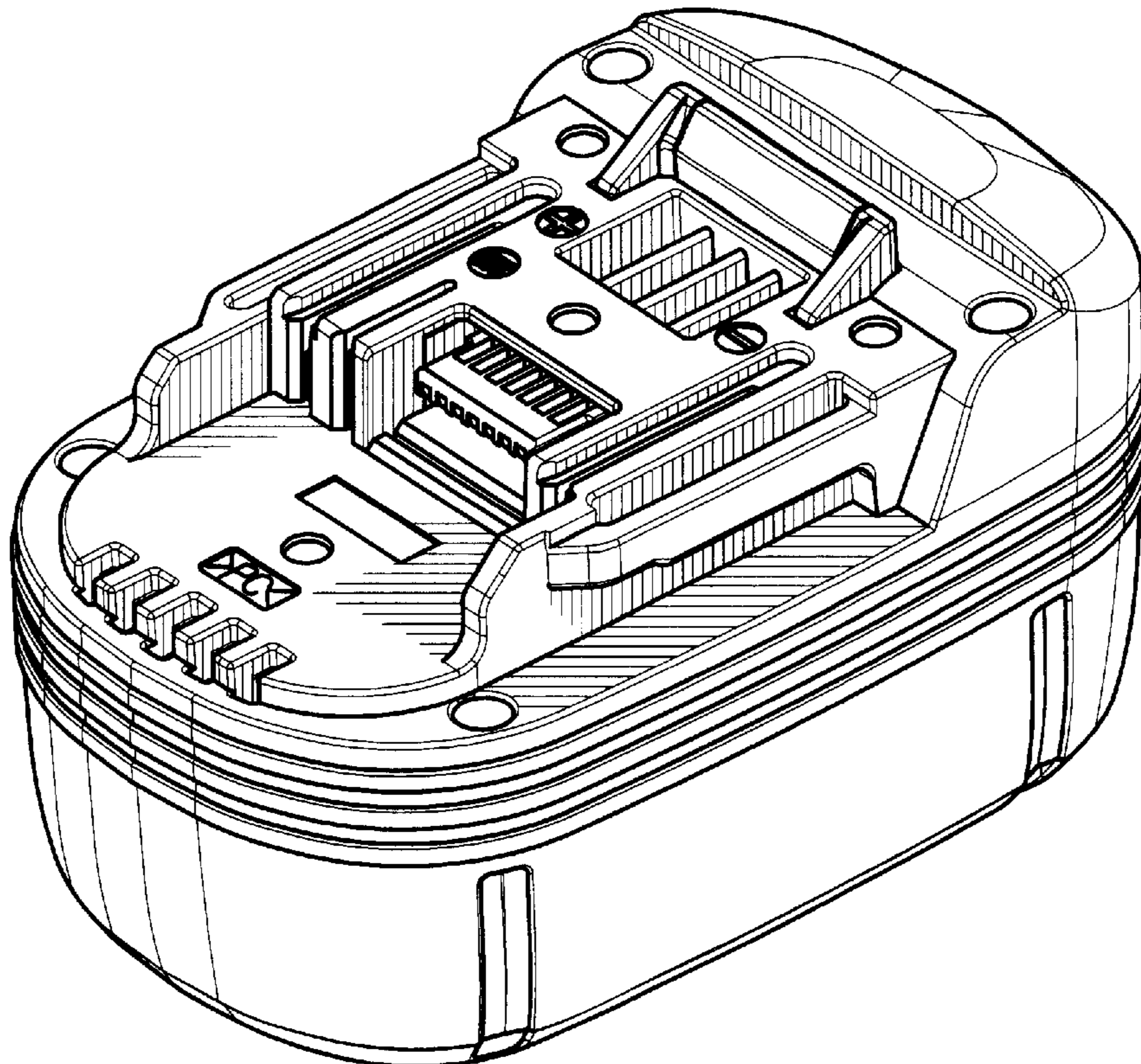

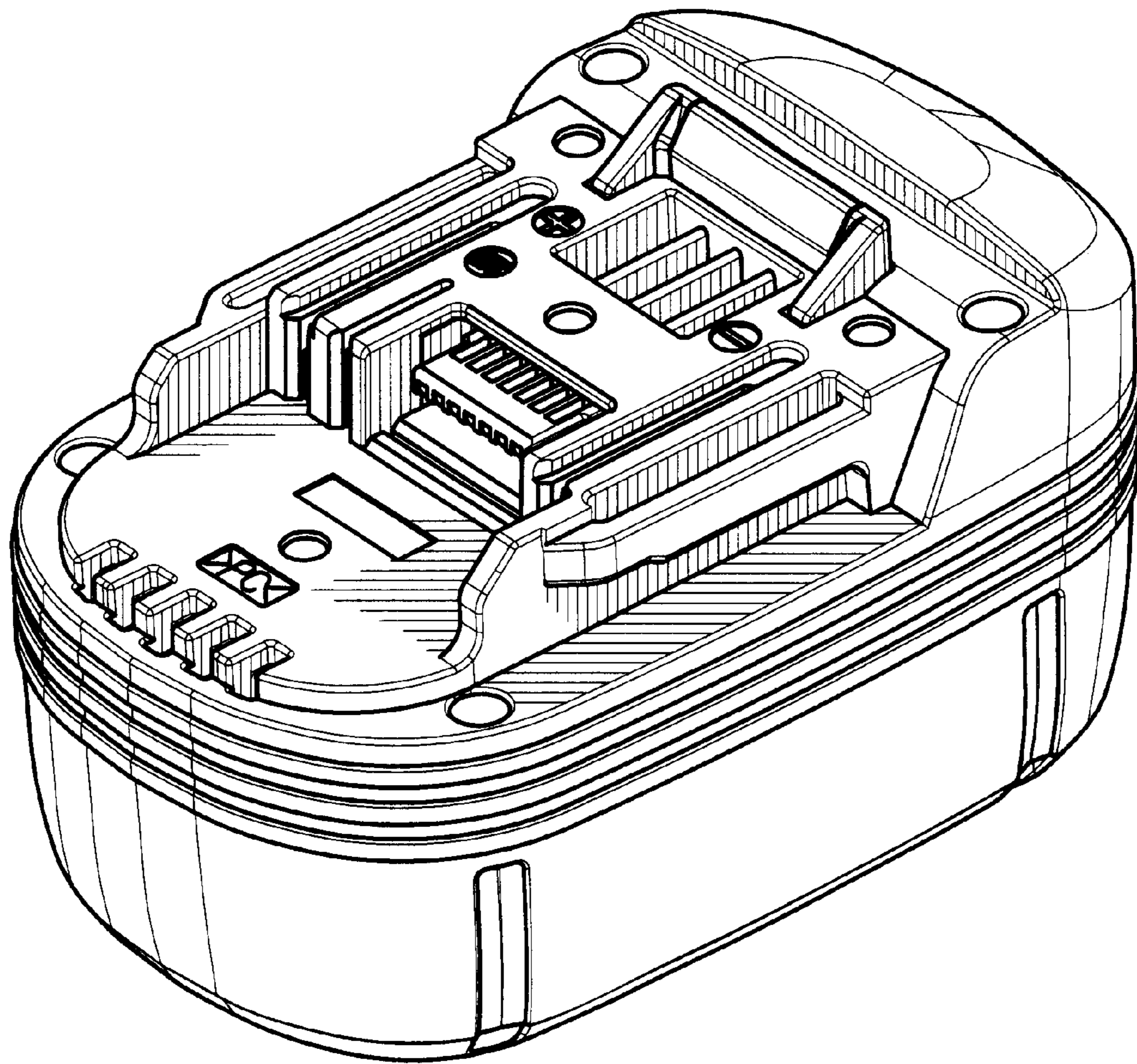

FIG. 1

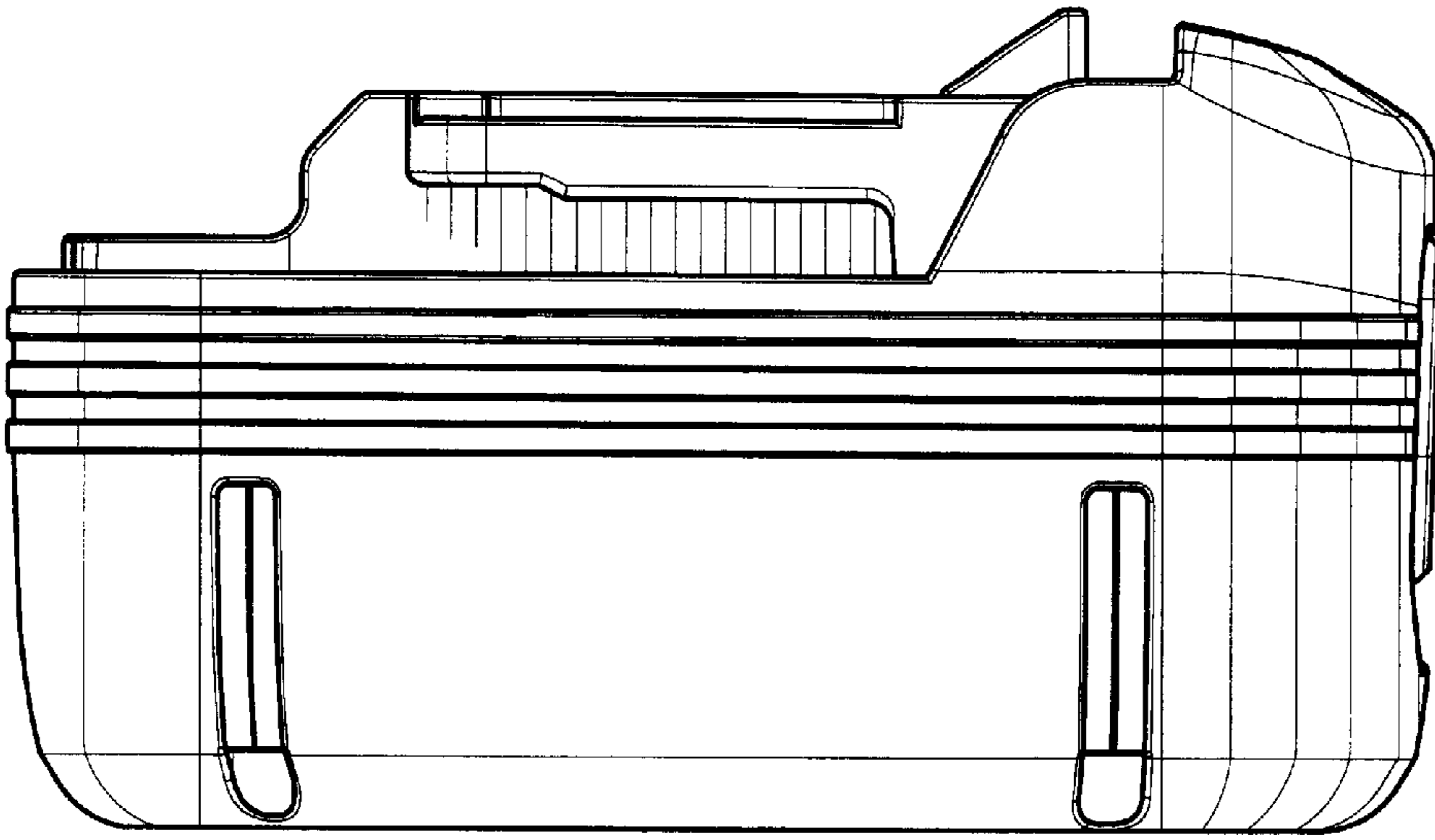

FIG. 2

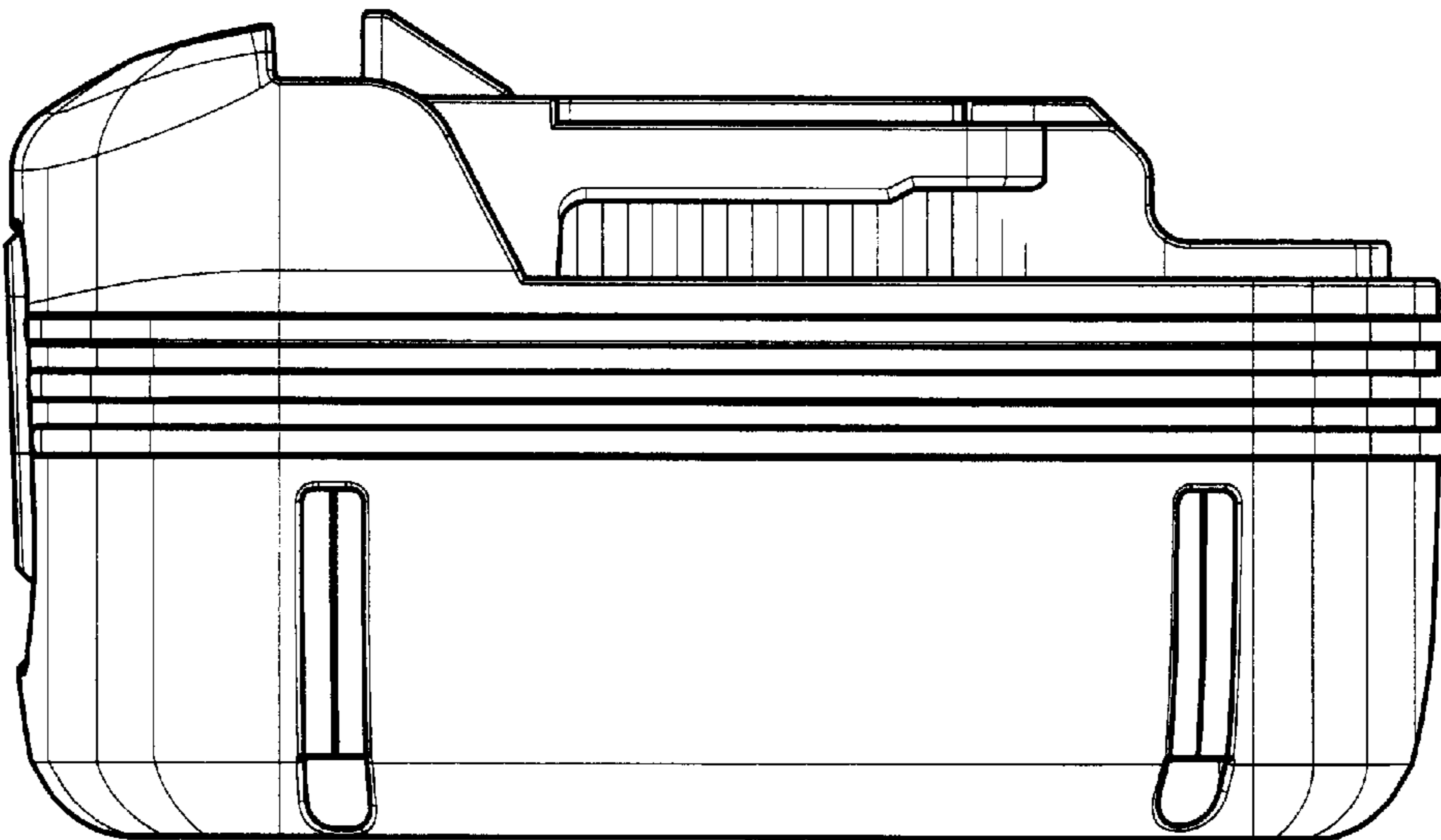

FIG. 3

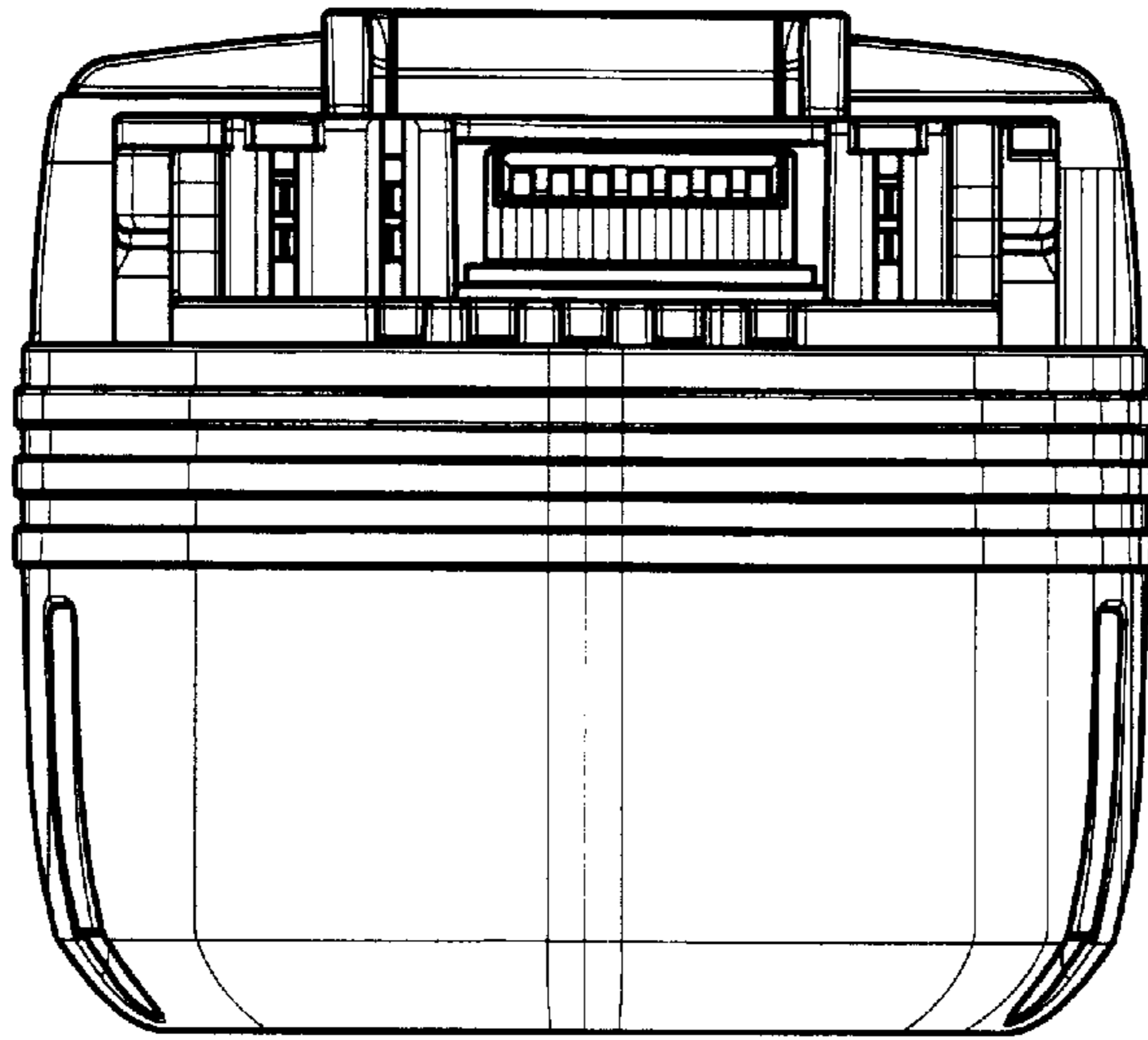

FIG. 4

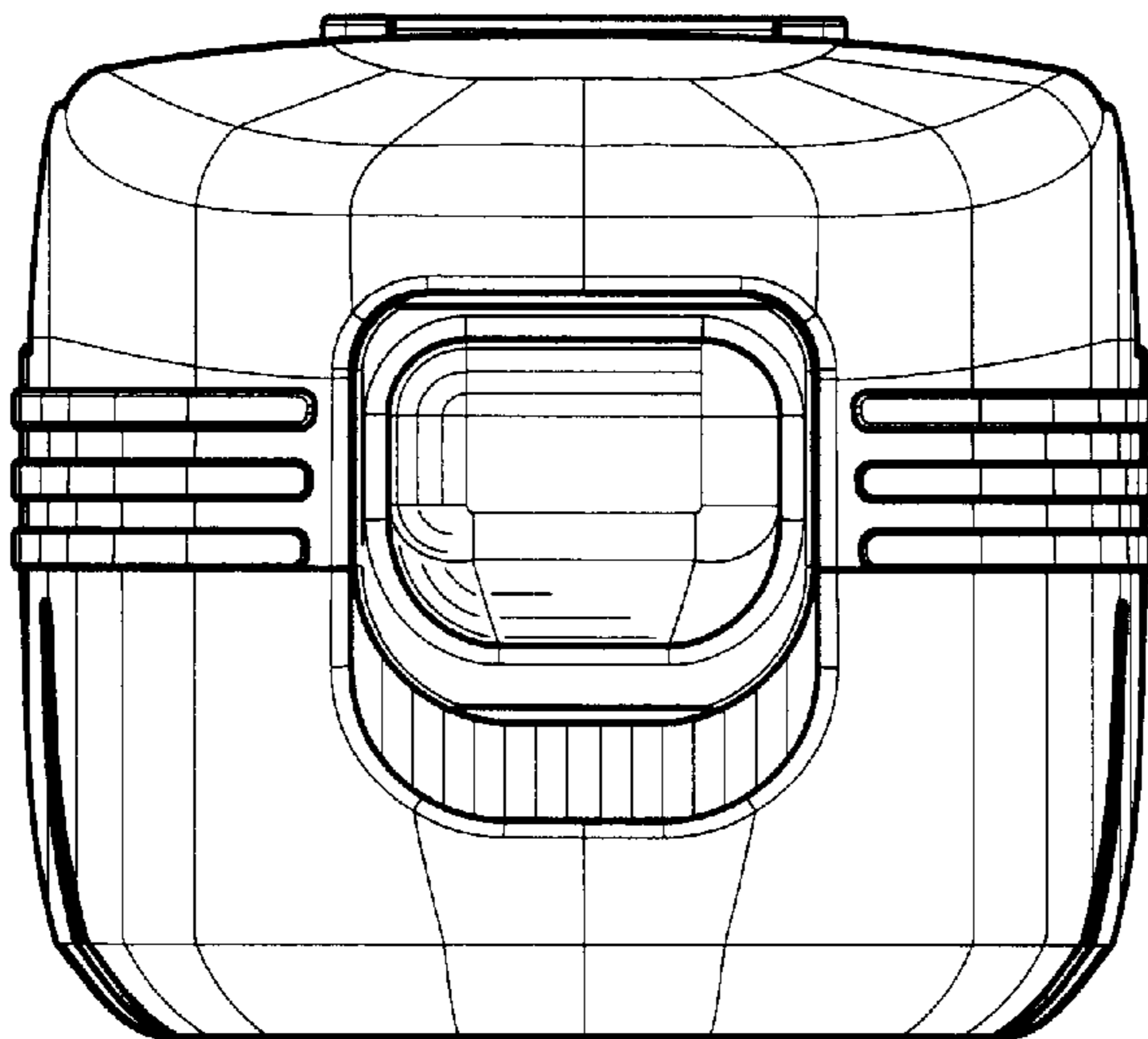

FIG. 5

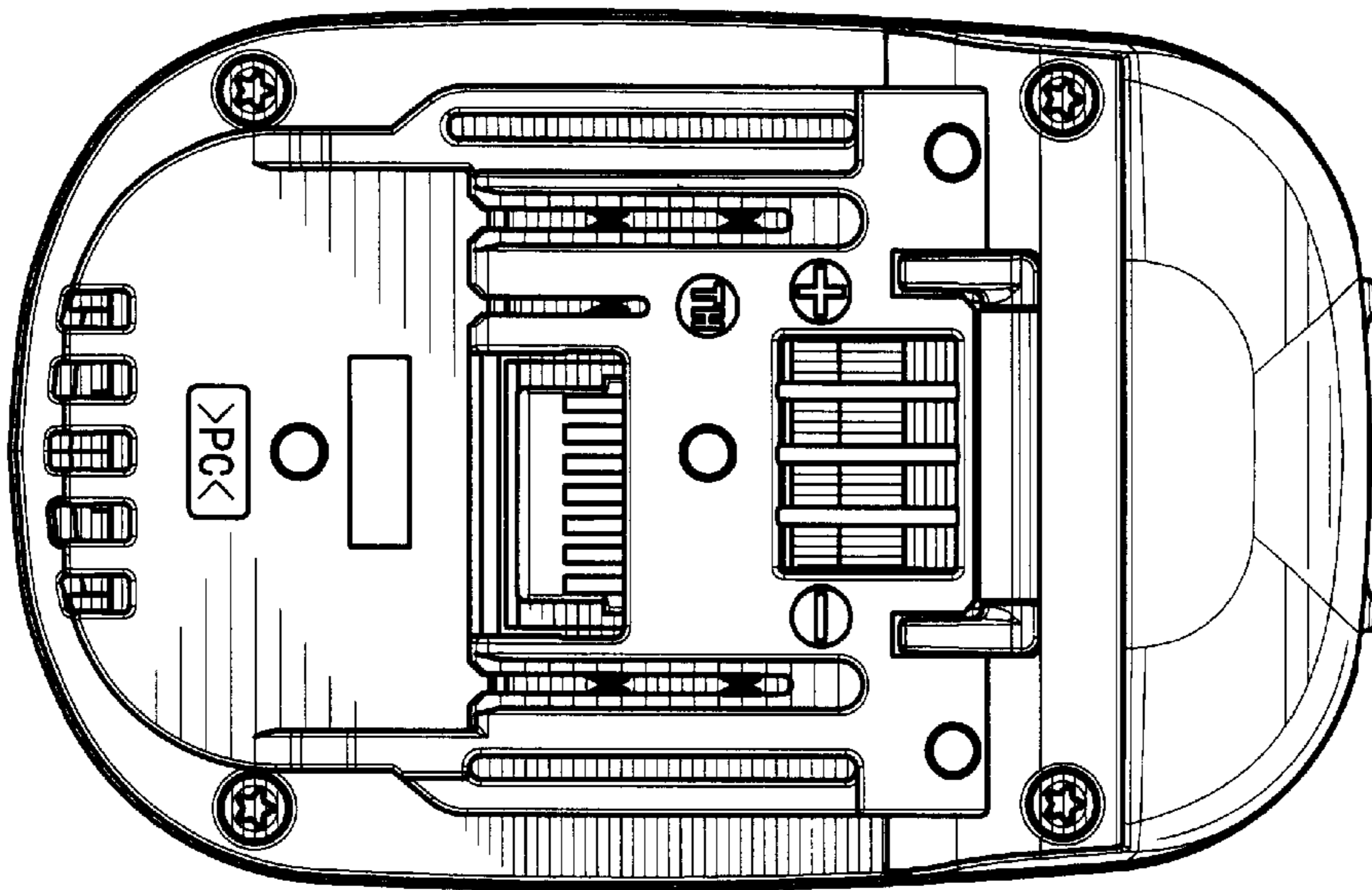

FIG. 6

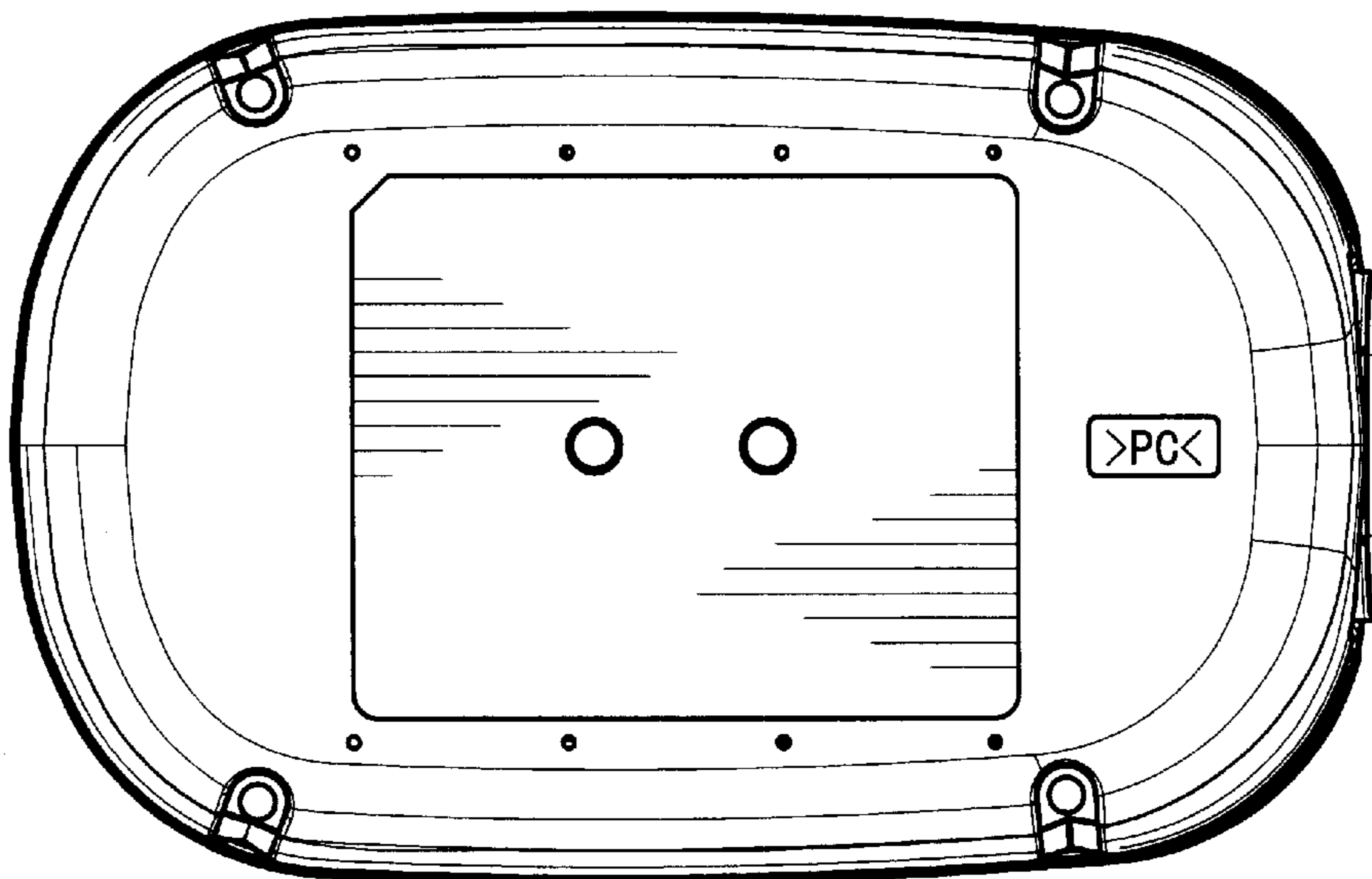

FIG. 7