



US00D477805S

(12) **United States Design Patent**
LaBelle et al.

(10) **Patent No.:** **US D477,805 S**

(45) **Date of Patent:** **** Jul. 29, 2003**

(54) **RAIL FOR A TONNEAU COVER AND/OR ANOTHER ACCESSORY**

(75) Inventors: **Donald L. LaBelle**, Macomb Township, MI (US); **Vincent M. McKeoun**, North Branch, MI (US)

(73) Assignee: **Durakon Acquisition Corp.**, Lapeer, MI (US)

(**) Term: **14 Years**

(21) Appl. No.: **29/169,195**

(22) Filed: **Oct. 15, 2002**

(51) **LOC (7) Cl.** **12-06**

(52) **U.S. Cl.** **D12/223**

(58) **Field of Search** D12/223, 400,
D12/221; 296/26.08, 26.09, 37.6, 39.1,
39.2, 100.02; 108/44, 143

(56) **References Cited**

U.S. PATENT DOCUMENTS

D324,195 S	*	2/1992	Ueno	D12/221
D333,607 S	*	3/1993	Isler	D8/382
5,456,511 A	*	10/1995	Webber	296/26.09
5,988,722 A	*	11/1999	Parri	296/26.09
6,059,339 A	*	5/2000	Madson	296/26.09
6,224,128 B1	*	5/2001	Mains	296/37.6
D446,181 S	*	8/2001	Darbishire	D12/223

OTHER PUBLICATIONS

U.S. patent application Ser. No. 60/415,956, LaBelle et al.

* cited by examiner

Primary Examiner—Melody N. Brown

(74) *Attorney, Agent, or Firm*—Christopher John Rudy

(57) **CLAIM**

The ornamental design for a rail for a tonneau cover and/or another accessory, as shown and described.

DESCRIPTION

FIG. 1 is front view of a rail for a tonneau cover and/or another accessory, the rail being of indeterminate length, which shows our new design;

FIG. 2 is a rear view thereof;

FIG. 3 is a top view thereof;

FIG. 4 is a bottom view thereof; and

FIG. 5 is a rear view of the rail, the front being a mirror image thereof.

FIG. 6 is an exploded perspective view of segments of the rail as set in place for mounting on a pickup truck; and,

FIG. 7 is a perspective view of segments of the rail as mounted on a pickup truck.

The portions of the pickup truck shown in broken lines are for illustrative purposes only and form no part of the claimed design.

1 Claim, 2 Drawing Sheets

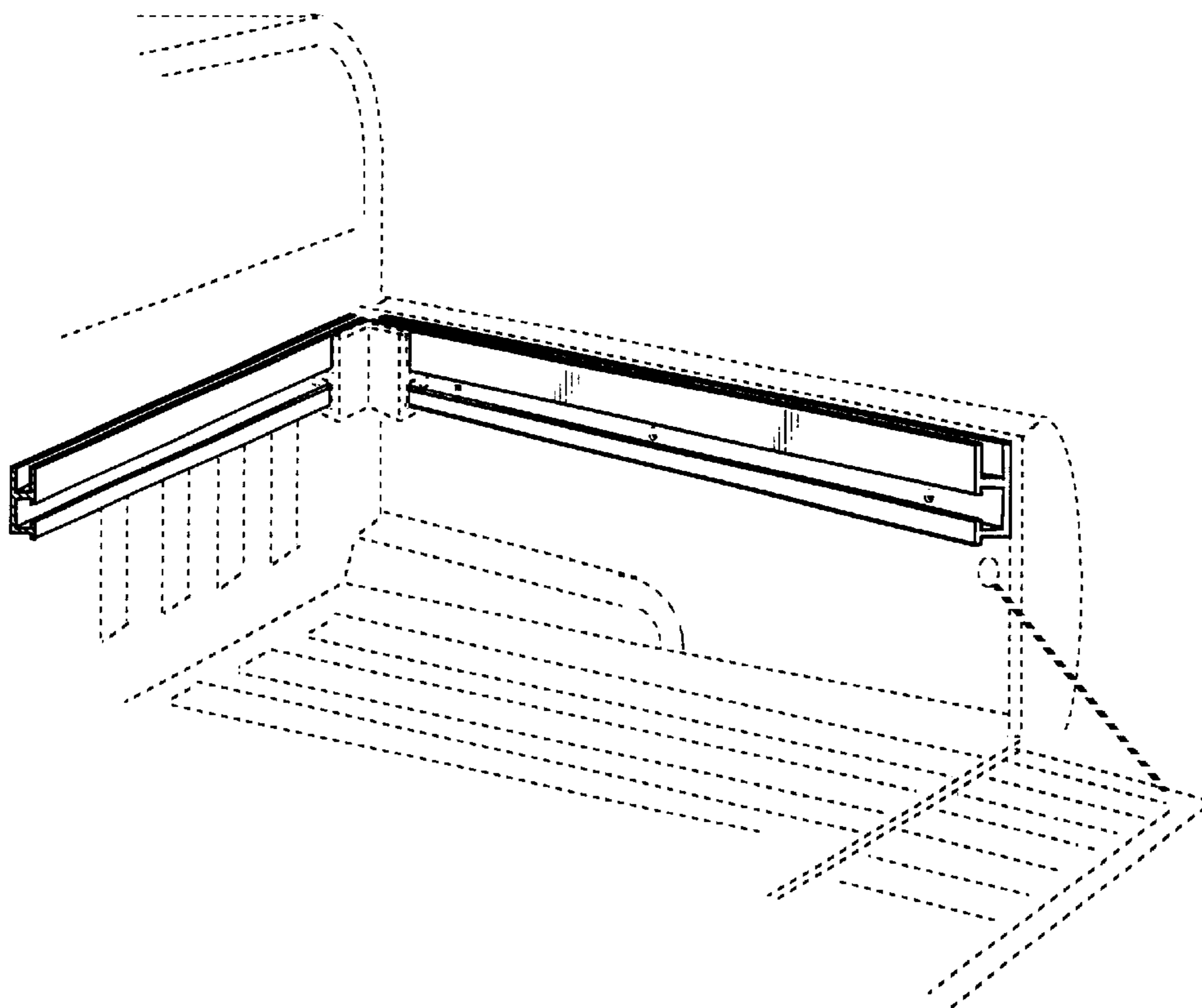

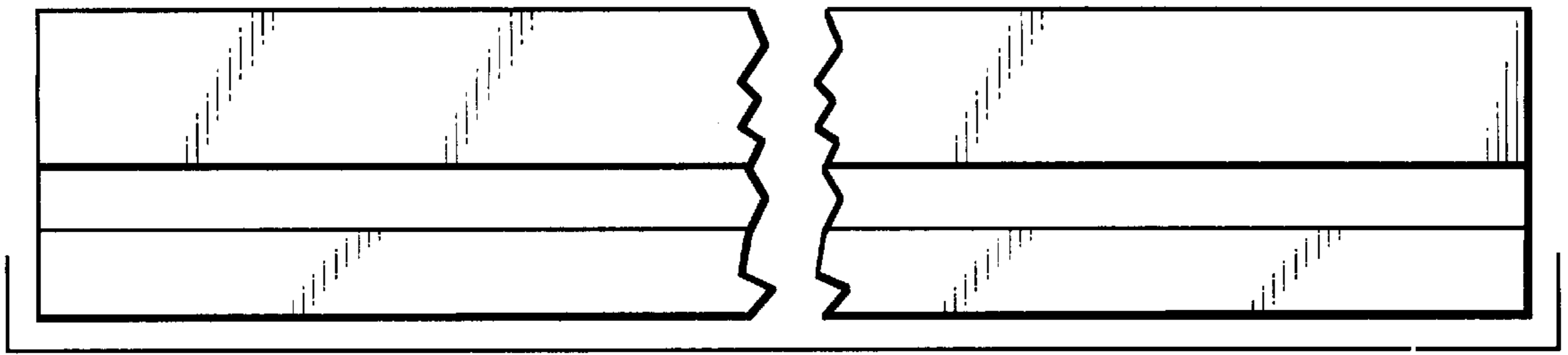

Fig. 1

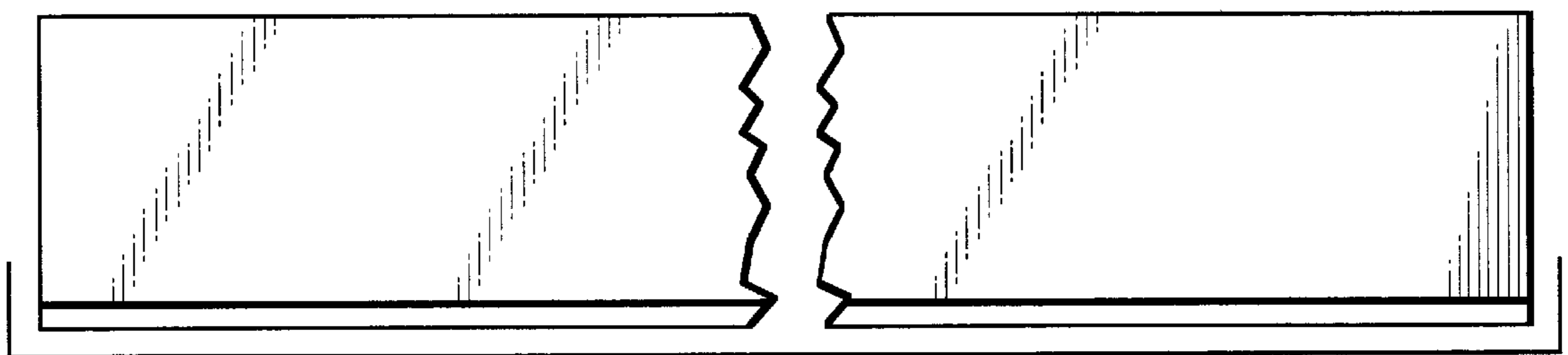

Fig. 2

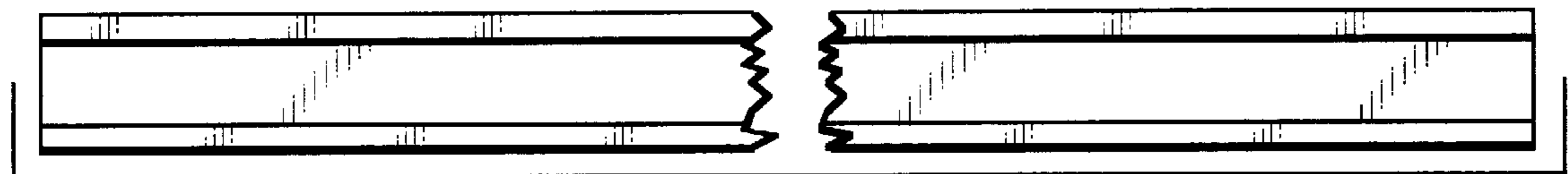

Fig. 3

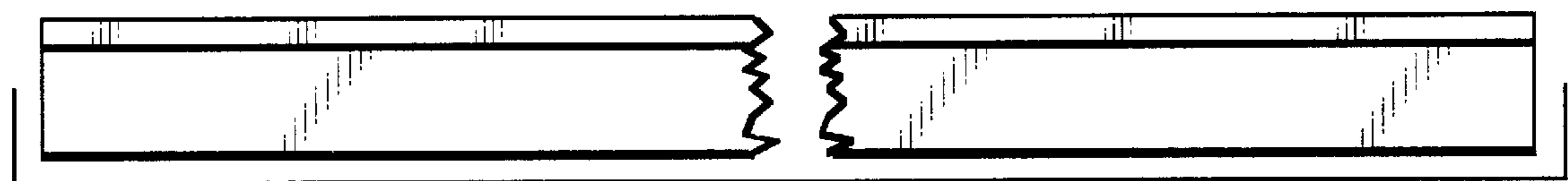

Fig. 4

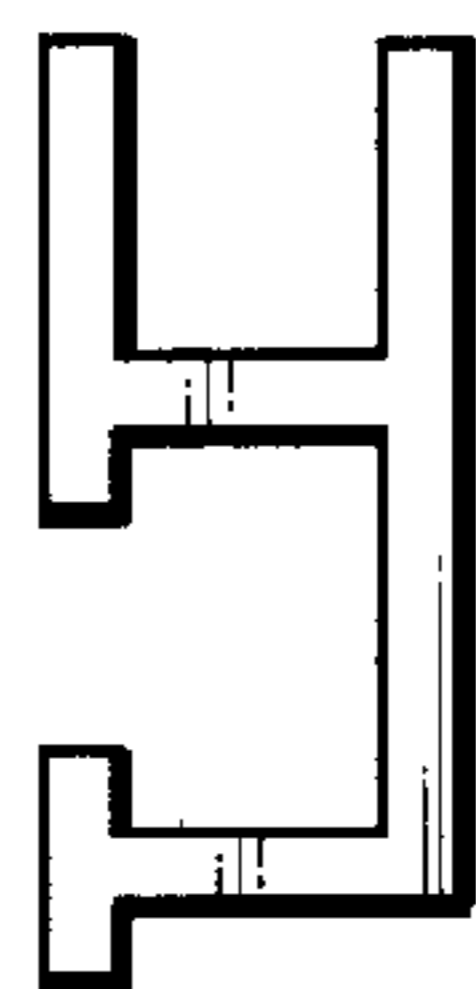

Fig. 5

Fig. 6

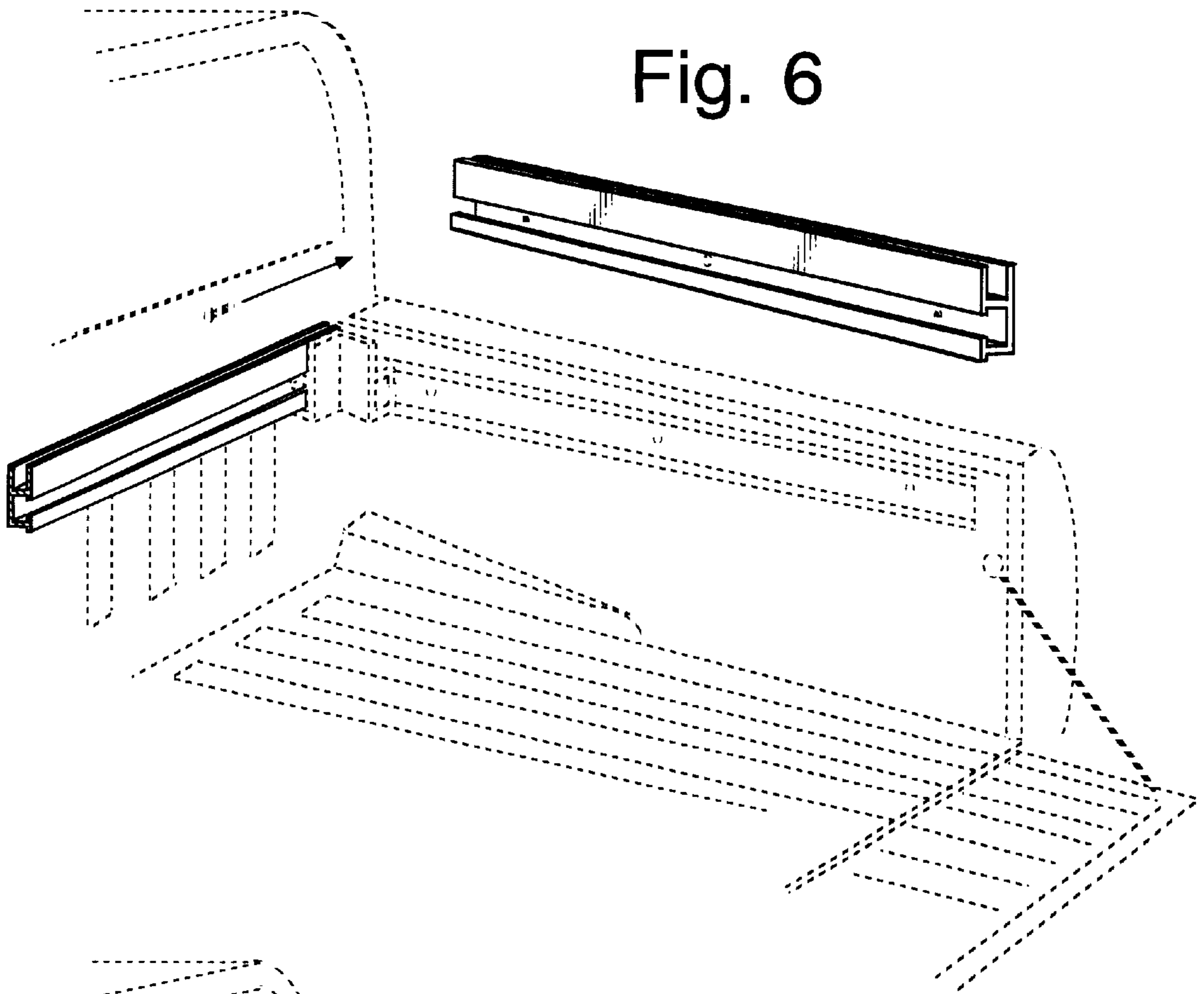

Fig. 7

