



US00D477553S

(12) **United States Design Patent** (10) **Patent No.:** **US D477,553 S**  
**Brock et al.** (45) **Date of Patent:** **\*\* Jul. 22, 2003**

(54) **AUXILIARY BRAKING UNIT**

OTHER PUBLICATIONS

(75) Inventors: **Alec D. Brock**, Colorado Springs, CO (US); **Daniel L. Decker, Jr.**, Castle Rock, CO (US)

Article by K. Stephen Busick entitled, "Supplemental Braking Systems," Jul., 2001 Issue of Family Motor Coaching magazine, pp. 60-75.

(73) Assignee: **Master Concepts, Inc.**, Sedalia, CO (US)

\* cited by examiner

(\*\*) Term: **14 Years**

*Primary Examiner*—Melody N. Brown

(74) *Attorney, Agent, or Firm*—Sheridan Ross P.C.

(21) Appl. No.: **29/166,507**

(22) Filed: **Aug. 27, 2002**

(57) **CLAIM**

The ornamental design for an auxiliary braking unit, as shown and described.

(51) **LOC (7) Cl.** ..... **12-16**

**DESCRIPTION**

(52) **U.S. Cl.** ..... **D12/180**

(58) **Field of Search** ..... D12/180; 188/352, 188/73.31, 73.45; 303/7, 20; 73/132

FIG. 1 is a perspective view of an auxiliary braking unit showing our new design, the broken lines showing environment for illustrative purposes only and forming no part of the claimed design;

(56) **References Cited**

**U.S. PATENT DOCUMENTS**

1,907,835 A	5/1933	Langbein	73/132
2,566,859 A	9/1951	Seeler	73/132
2,676,225 A	4/1954	Jubell	73/132
2,711,228 A	6/1955	Shank	73/132
2,964,965 A	12/1960	Hanson	73/132
3,662,593 A	5/1972	Pirrello et al.	73/132
3,866,719 A	2/1975	Streutker	188/3 R
3,877,318 A	4/1975	Castoe	74/481
3,991,609 A	11/1976	Asmus et al.	73/132
4,186,595 A	2/1980	Domitter	73/132
D308,525 S *	6/1990	Robbins	D15/4
5,012,689 A	5/1991	Smith	74/89.17
5,031,729 A	7/1991	Wittkop et al.	188/3 H
5,299,668 A	4/1994	Youngers et al.	188/352
5,411,321 A	5/1995	Harness	303/7
D370,448 S *	6/1996	McCoy et al.	D12/180
5,911,483 A	6/1999	Overhulser	303/7
5,915,797 A	6/1999	Springer	303/7
5,915,798 A	6/1999	Ford	303/7
D418,098 S *	12/1999	Wallace	D12/180
6,095,619 A	8/2000	Granata	303/7
6,126,246 A	10/2000	Decker, Sr., et al.	303/7
6,131,712 A	10/2000	Rhodenizer	188/352

FIG. 2 is a front elevation view of the invention illustrated in FIG. 1;

FIG. 3 is a rear elevation view of the invention illustrated in FIG. 1;

FIG. 4 is a left elevation view of the invention illustrated in FIG. 1;

FIG. 5 is a right perspective view of the invention illustrated in FIG. 1;

FIG. 6 is a top plan view of the invention illustrated in FIG. 1;

FIG. 7 is a bottom plan view of the invention illustrated in FIG. 1;

FIG. 8 is a perspective view of a second embodiment of the invention illustrated in FIG. 1, the broken lines showing environment for illustrative purposes only and forming no part of the claimed design;

FIG. 9 is a front elevation view of the invention illustrated in FIG. 8;

FIG. 10 is a rear elevation view of the invention illustrated in FIG. 8;

FIG. 11 is a left elevation view of the invention illustrated in FIG. 8;

FIG. 12 is a right perspective view of the invention illustrated in FIG. 8;

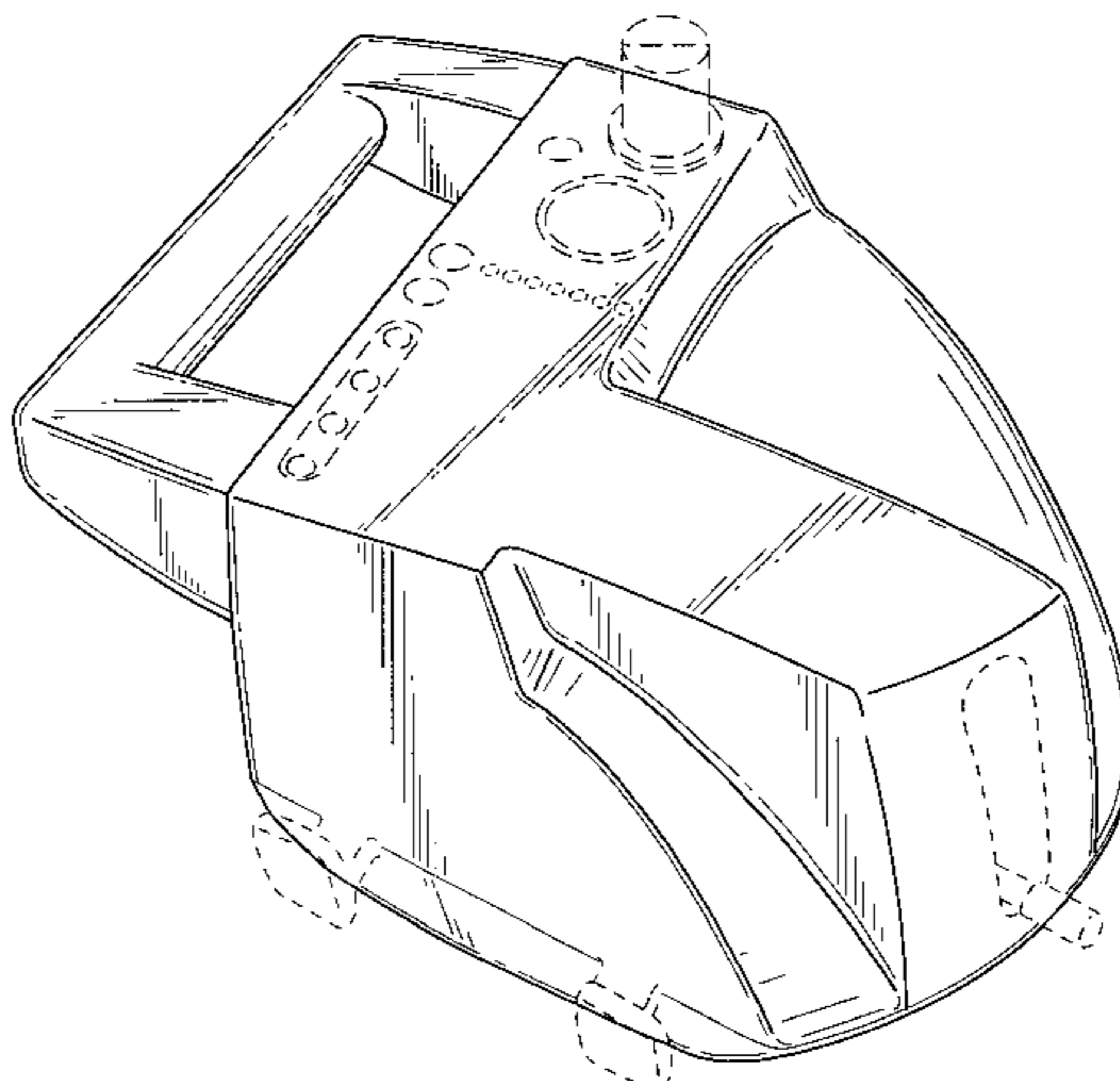

FIG. 13 is a top plan view of the invention illustrated in FIG. 8;

FIG. 14 is a bottom plan view of the invention illustrated in FIG. 8;

FIG. 15 is a perspective view of a third embodiment of the invention illustrated in FIG. 1, the broken lines showing the environment for illustrative purposes only and forming no part of the claimed design;

FIG. 16 is a front elevation view of the invention illustrated in FIG. 15;

FIG. 17 is a rear elevation view of the invention illustrated in FIG. 15;

FIG. 18 is a left elevation view of the invention illustrated in FIG. 15;

FIG. 19 is a right perspective view of the invention illustrated in FIG. 15;

FIG. 20 is a top plan view of the invention illustrated in FIG. 15;

FIG. 21 is a bottom plan view of the invention illustrated in FIG. 15;

FIG. 22 is a fourth embodiment of the invention illustrating FIG. 1, the broken lines showing environment for illustrative purposes only and forming no part of the claimed design;

FIG. 23 is a front elevation view of the invention illustrated in FIG. 22;

FIG. 24 is a rear elevation view of the invention illustrated in FIG. 22;

FIG. 25 is a left elevation view of the invention illustrated in FIG. 22;

FIG. 26 is a right perspective view of the invention illustrated in FIG. 22;

FIG. 27 is a top plan view of the invention illustrated in FIG. 22;

FIG. 28 is a bottom plan view of the invention illustrated in FIG. 22;

FIG. 29 is a rear elevation view of the invention illustrated in FIG. 22, with the handle shown extended in a position of use;

FIG. 30 is a rear elevation view of the invention illustrated in FIG. 22, with the handle retracted in an alternative position of use;

FIG. 31 is a fifth embodiment of the invention illustrated in FIG. 1, the broken lines showing environment for illustrative purposes only and forming no part of the claimed design;

FIG. 32 is a front elevation view of the invention illustrated in FIG. 31;

FIG. 33 is a rear elevation view of the invention illustrated in FIG. 31;

FIG. 34 is a left elevation view of the invention illustrated in FIG. 31;

FIG. 35 is a right perspective view of the invention illustrated in FIG. 31;

FIG. 36 is a top plan view of the invention illustrated in FIG. 31; and,

FIG. 37 is a bottom plan view of the invention illustrated in FIG. 31.

**1 Claim, 26 Drawing Sheets**

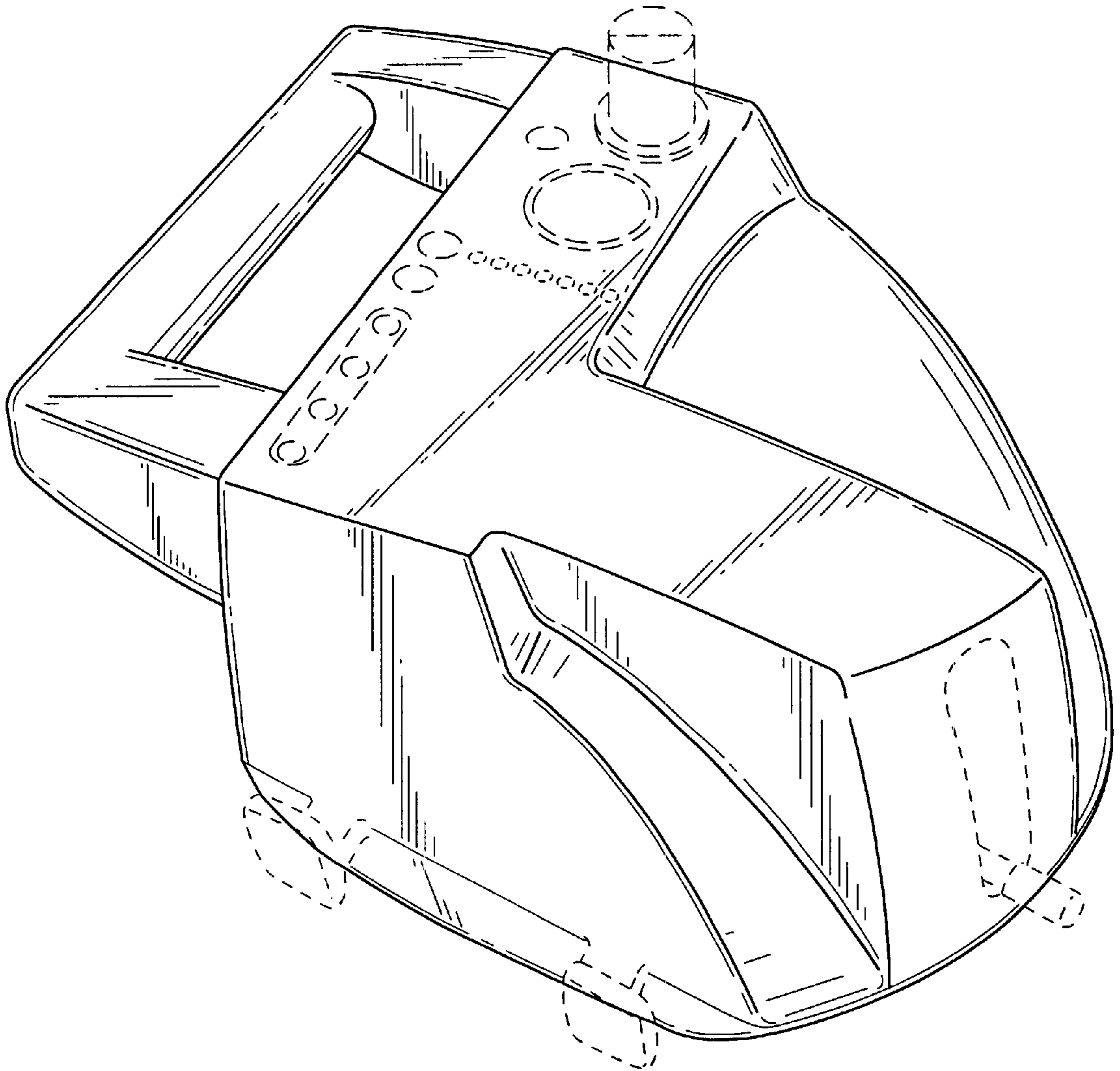

FIG. 1

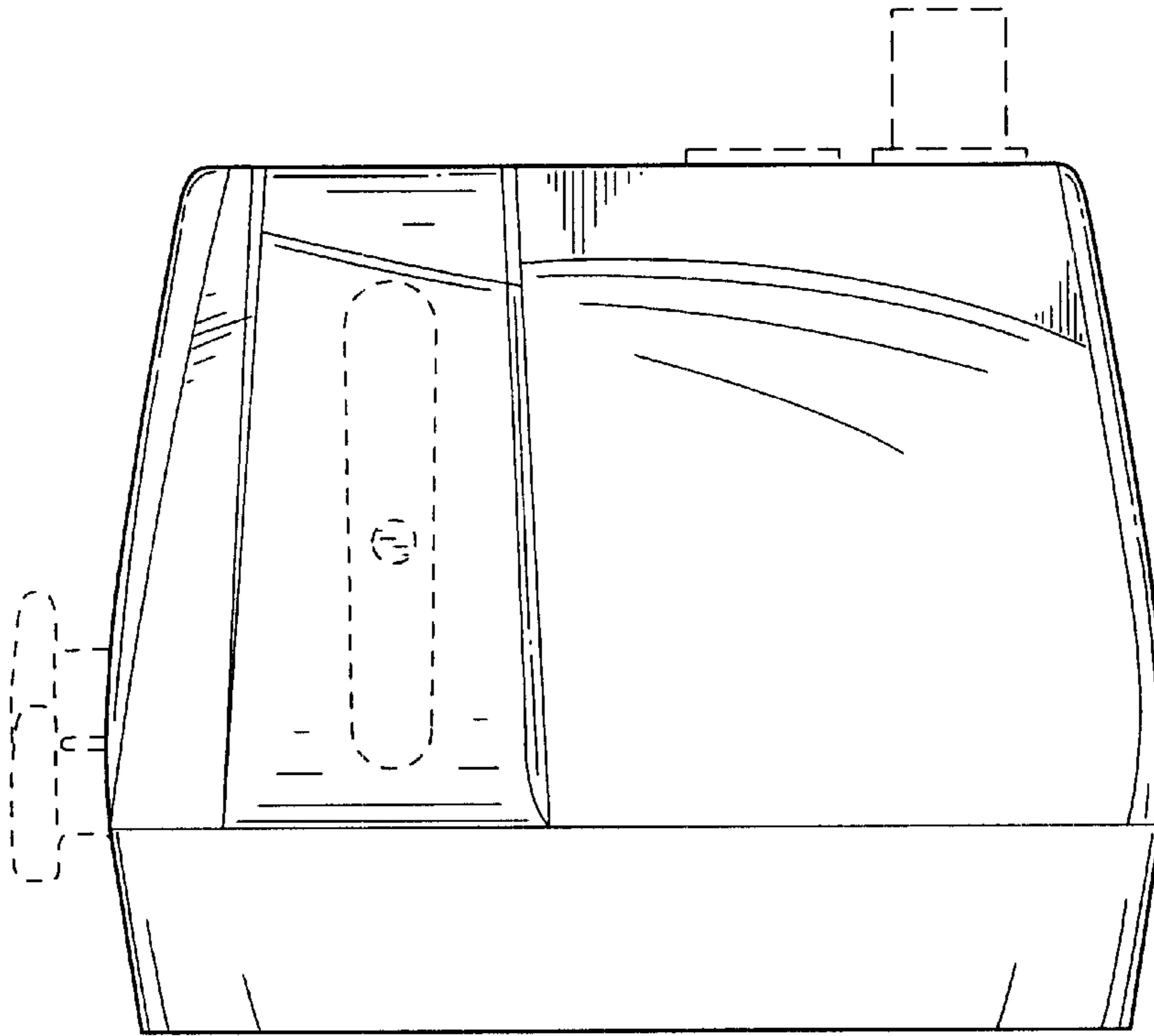

FIG. 2

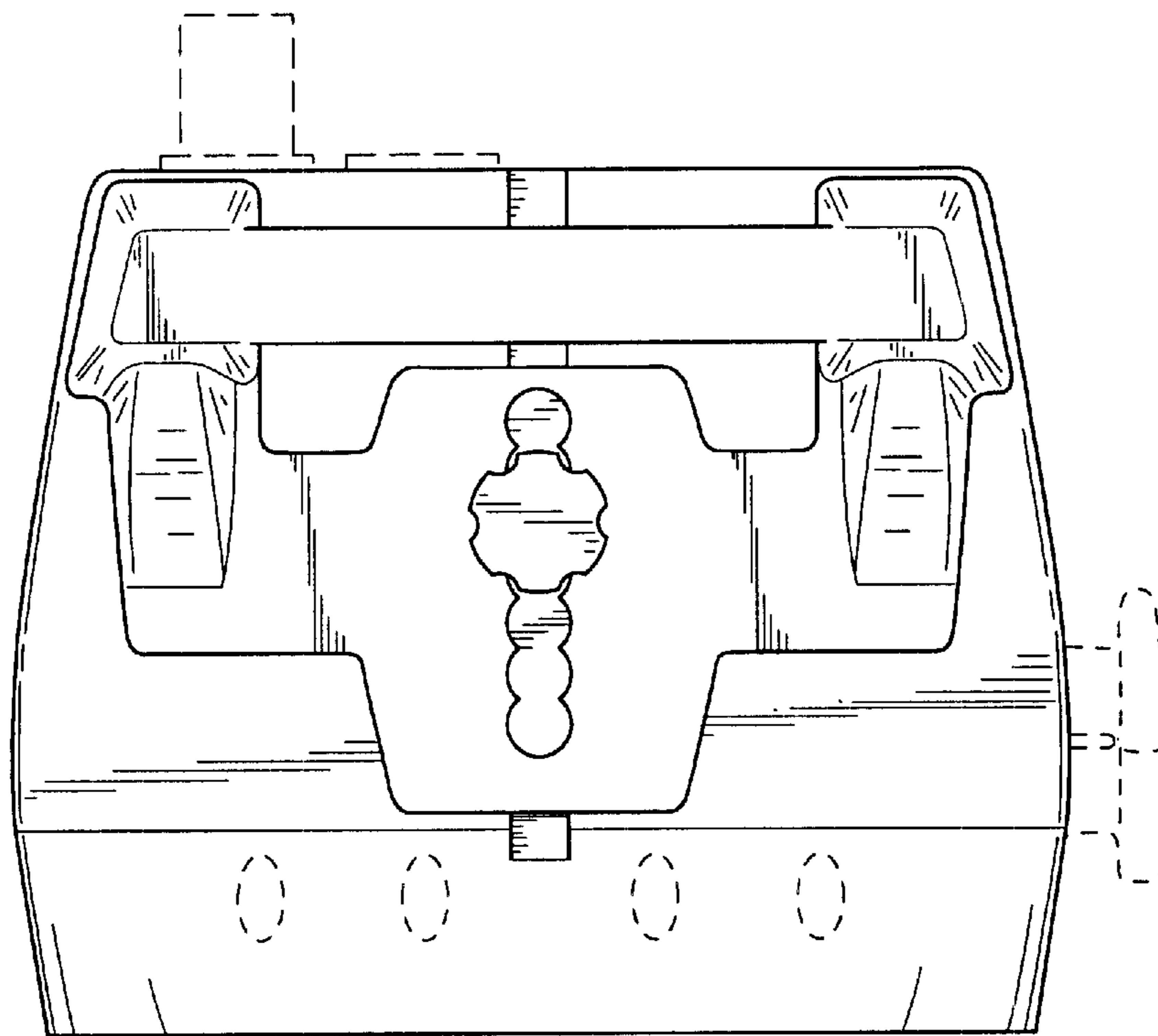

FIG. 3

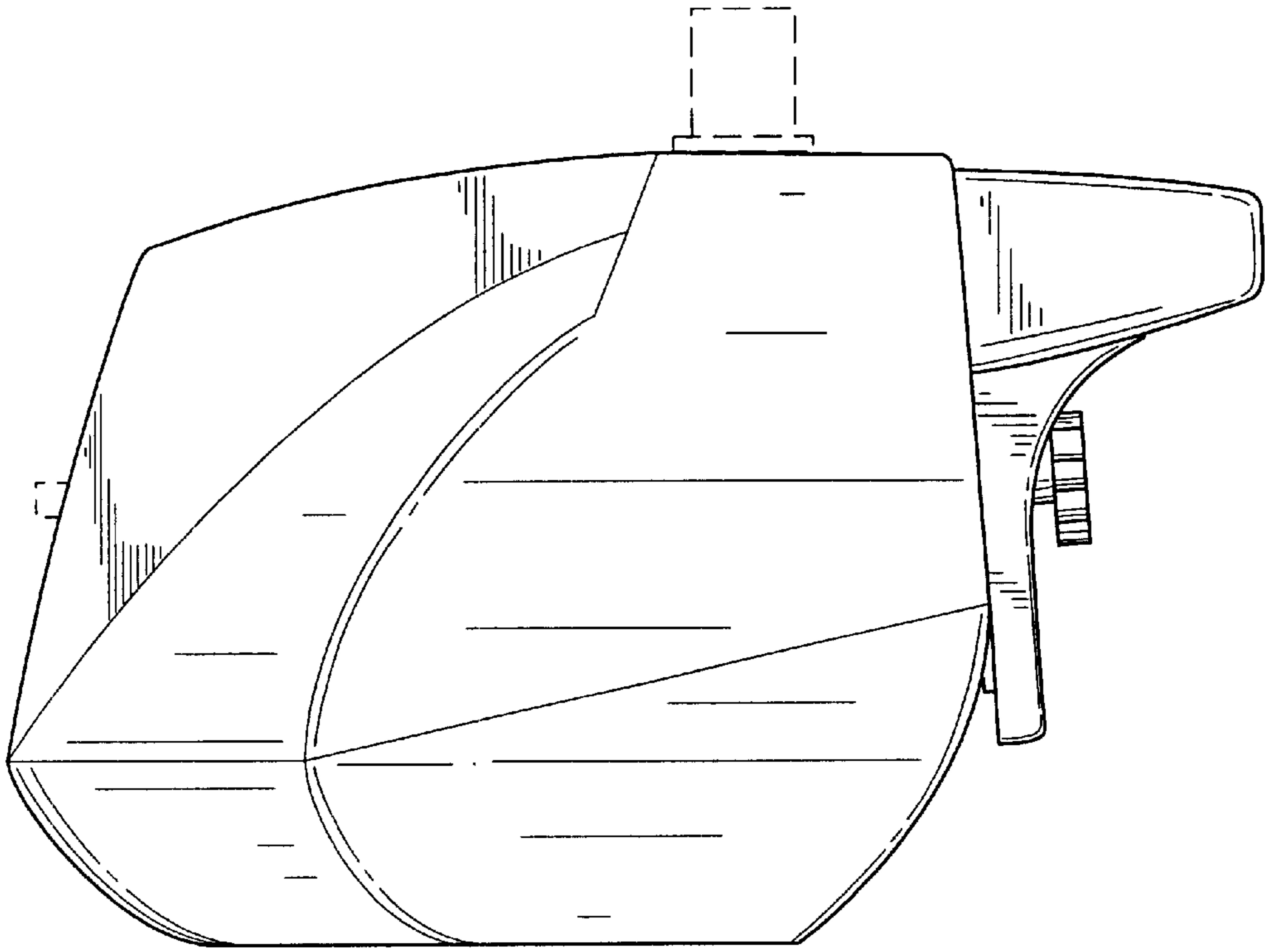

FIG. 4

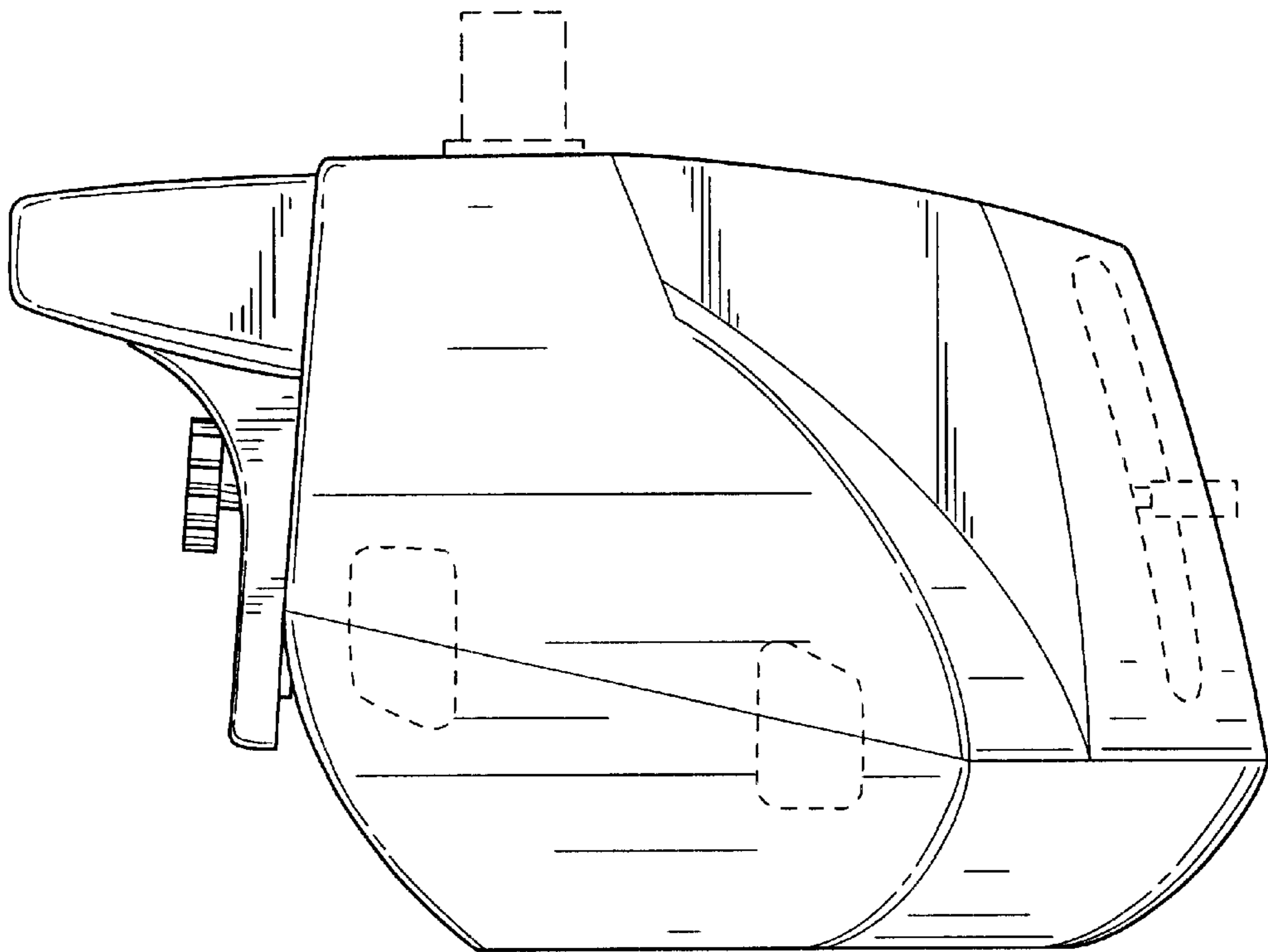

FIG. 5

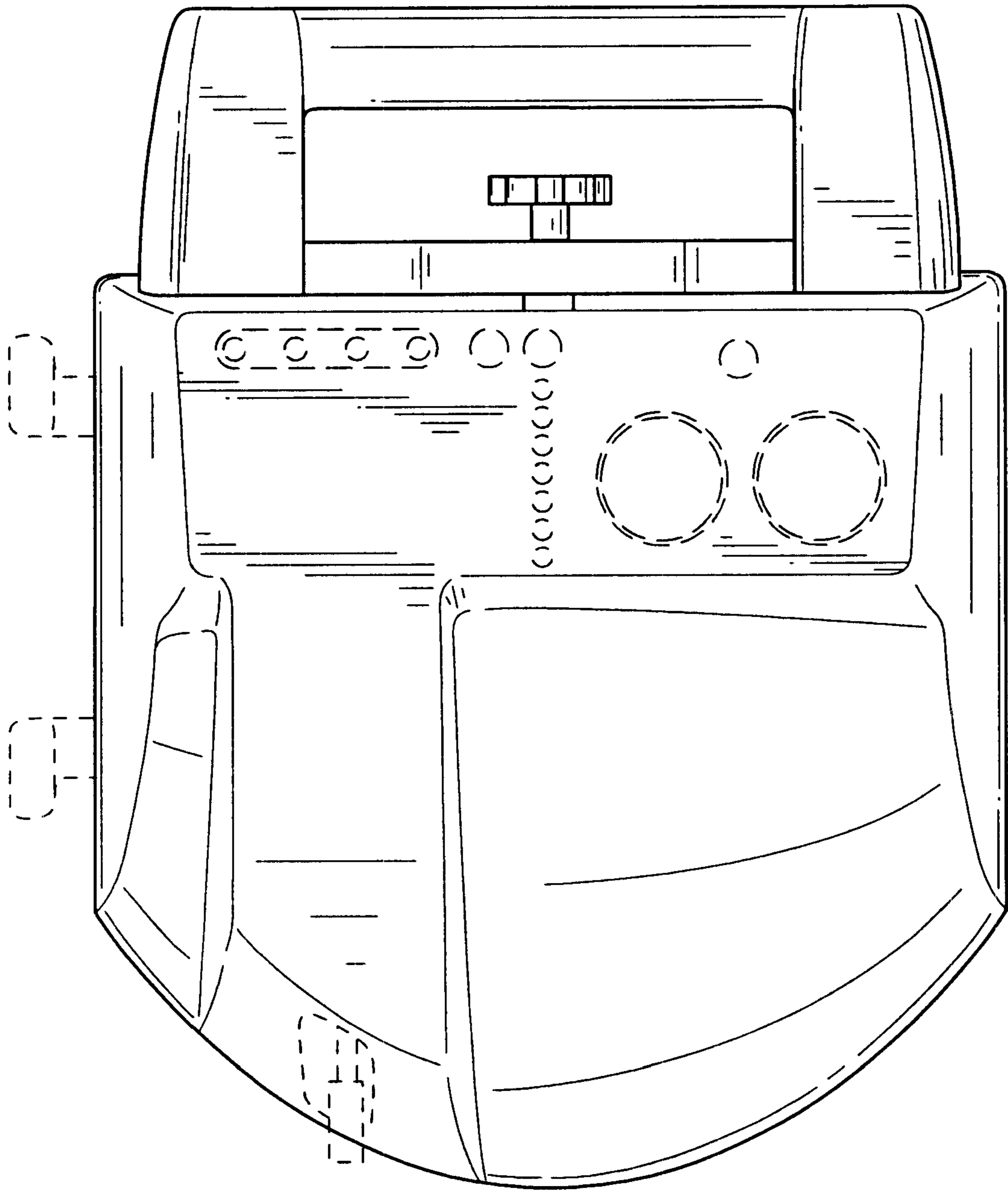

FIG.6

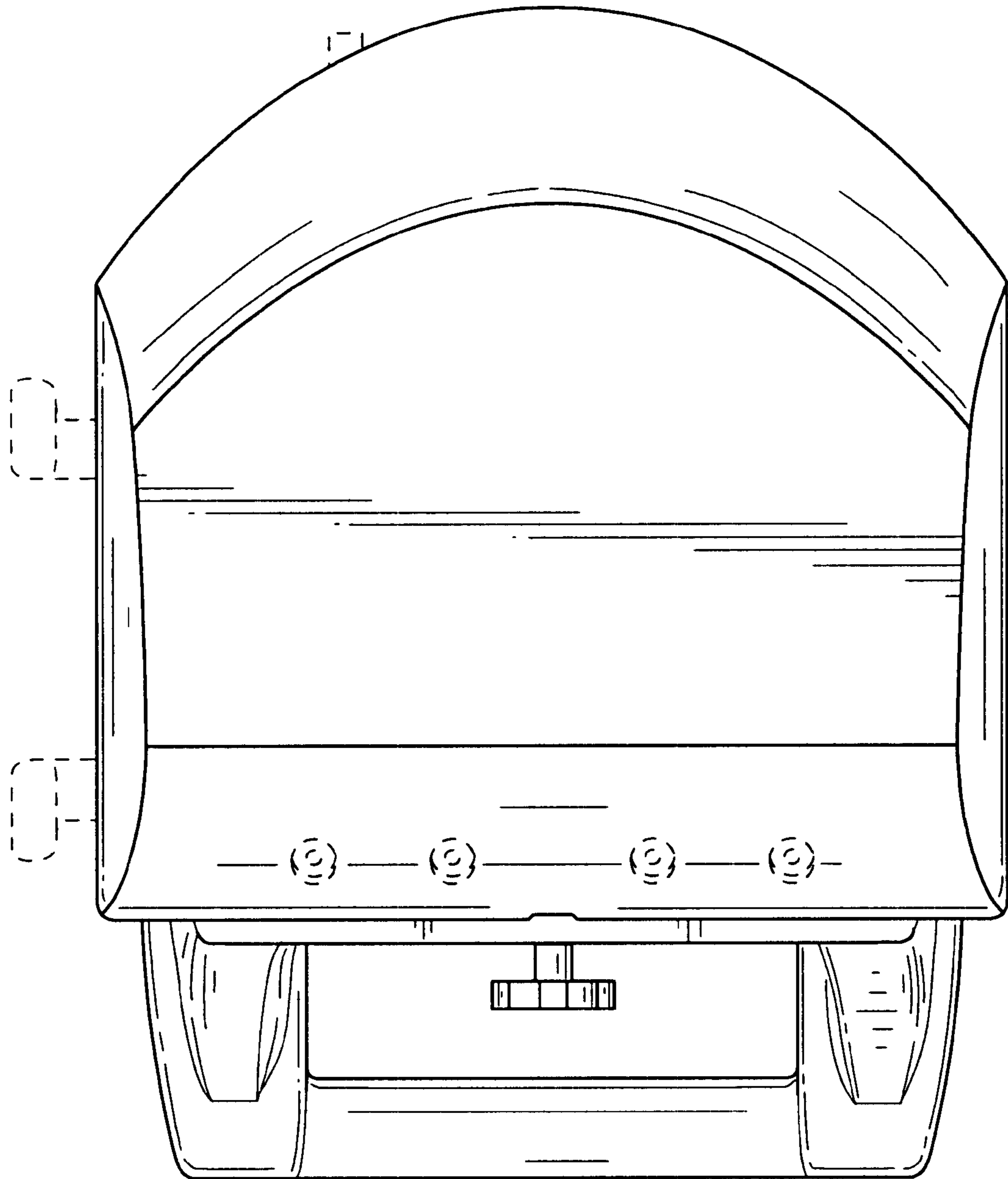

FIG. 7

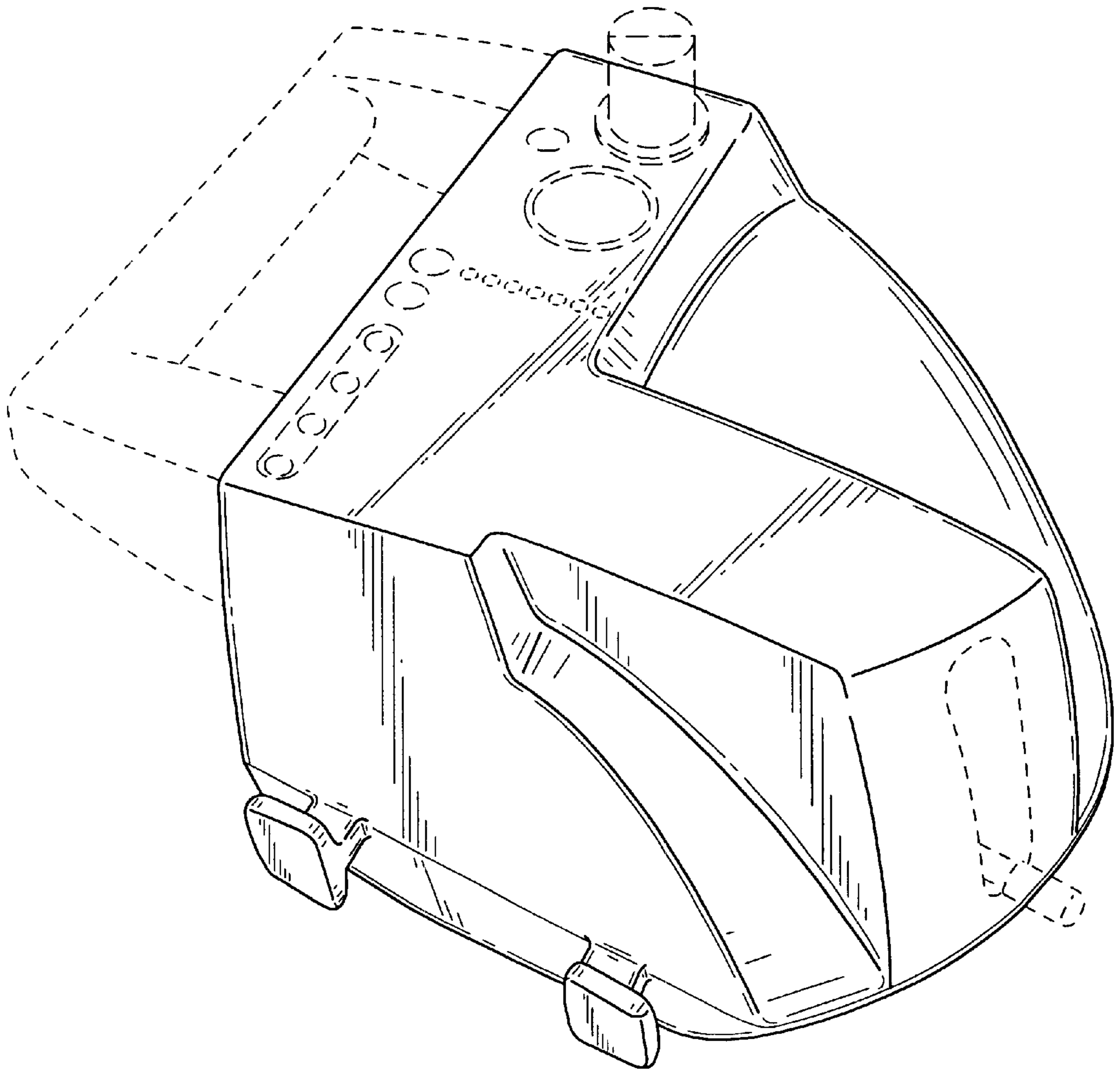

FIG.8



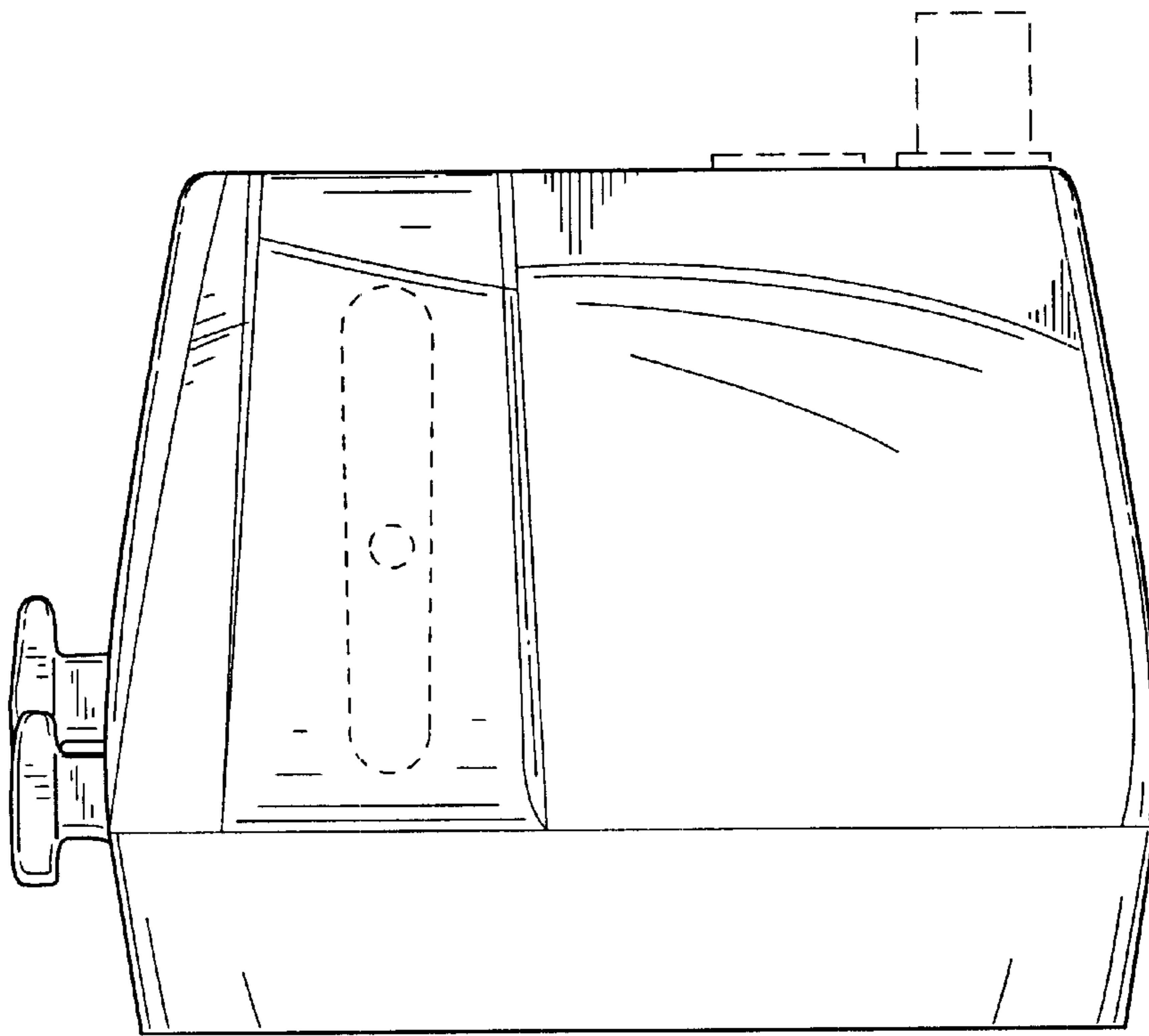

FIG. 9

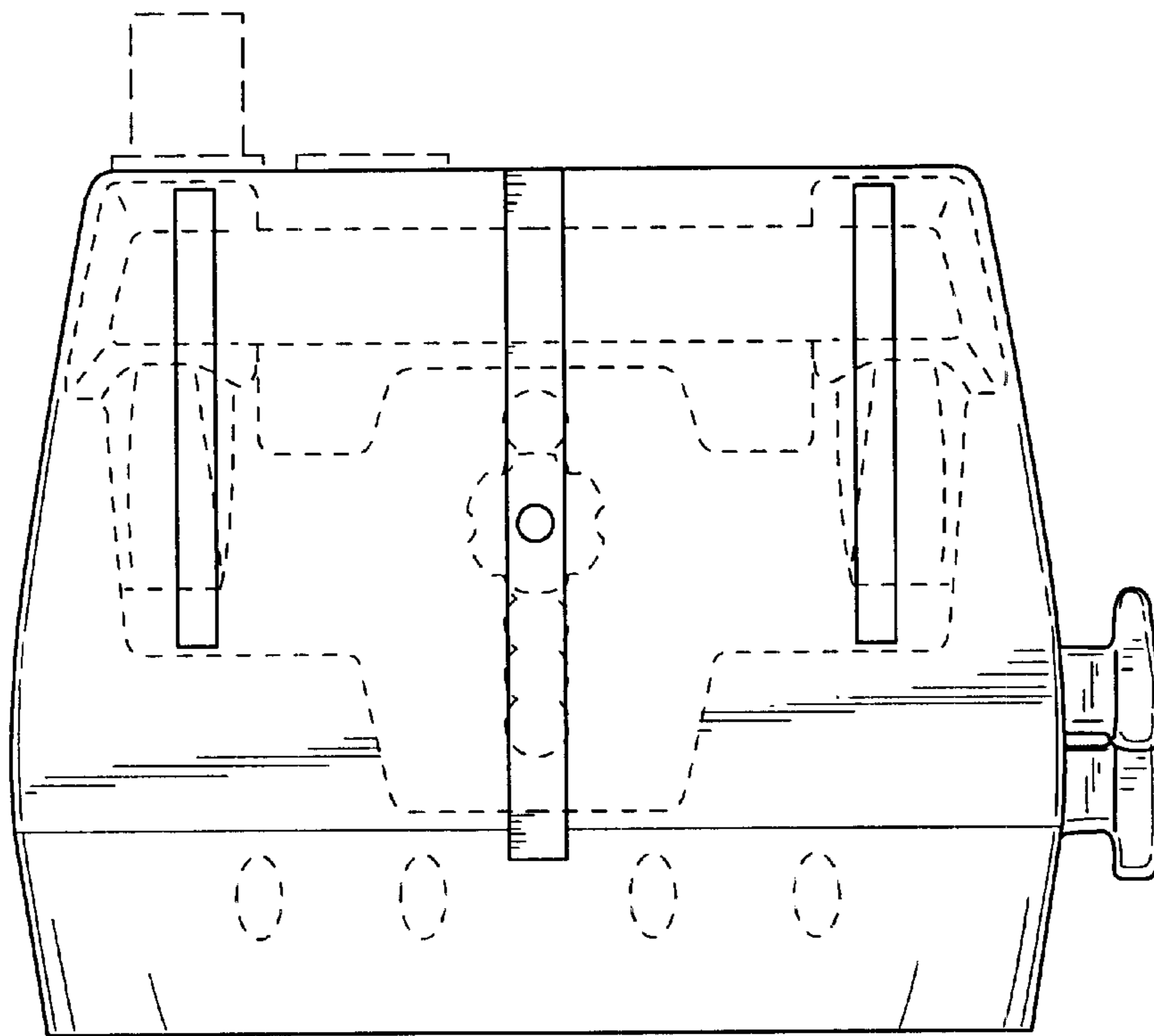

FIG. 10

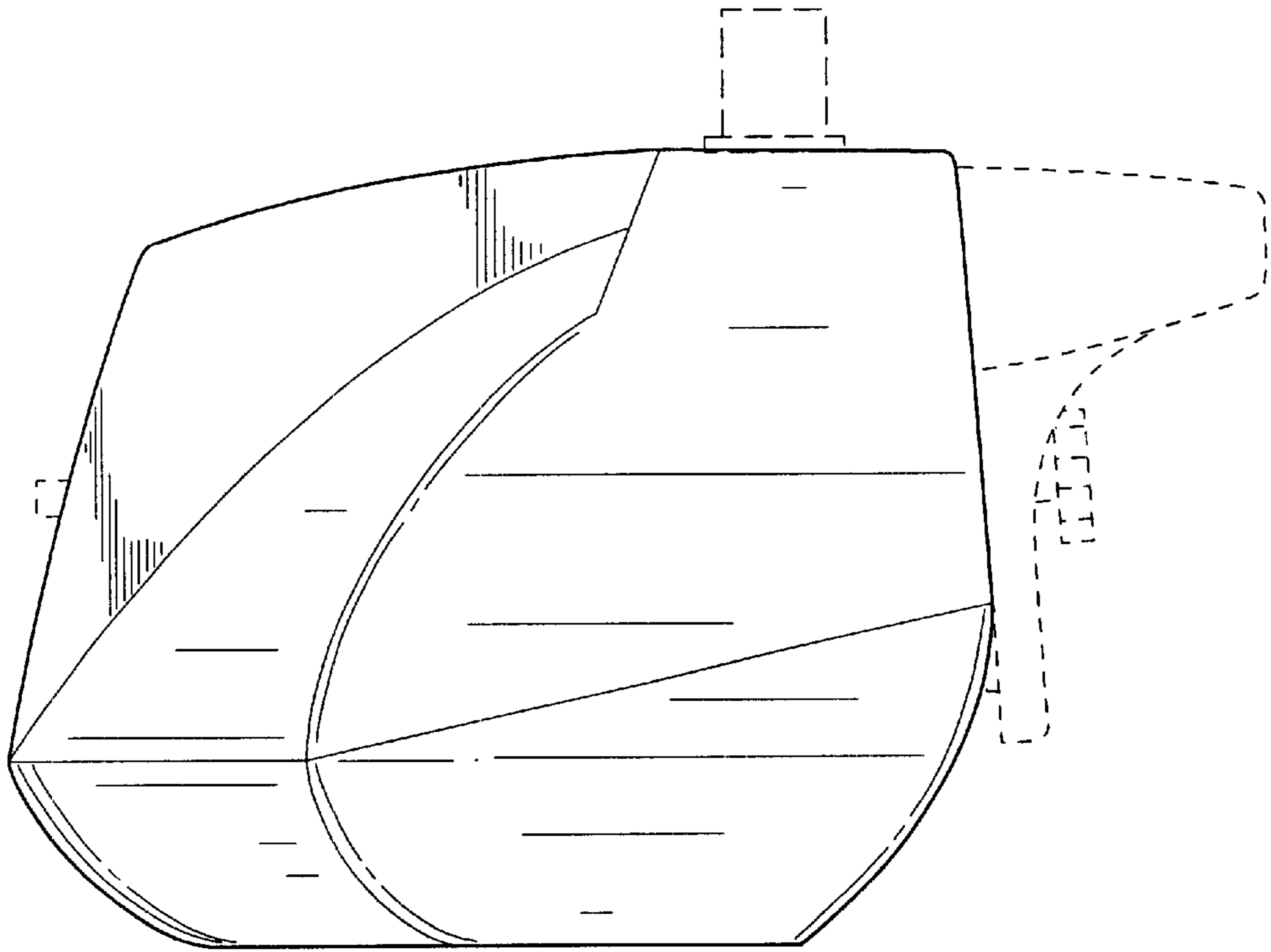

FIG. 11

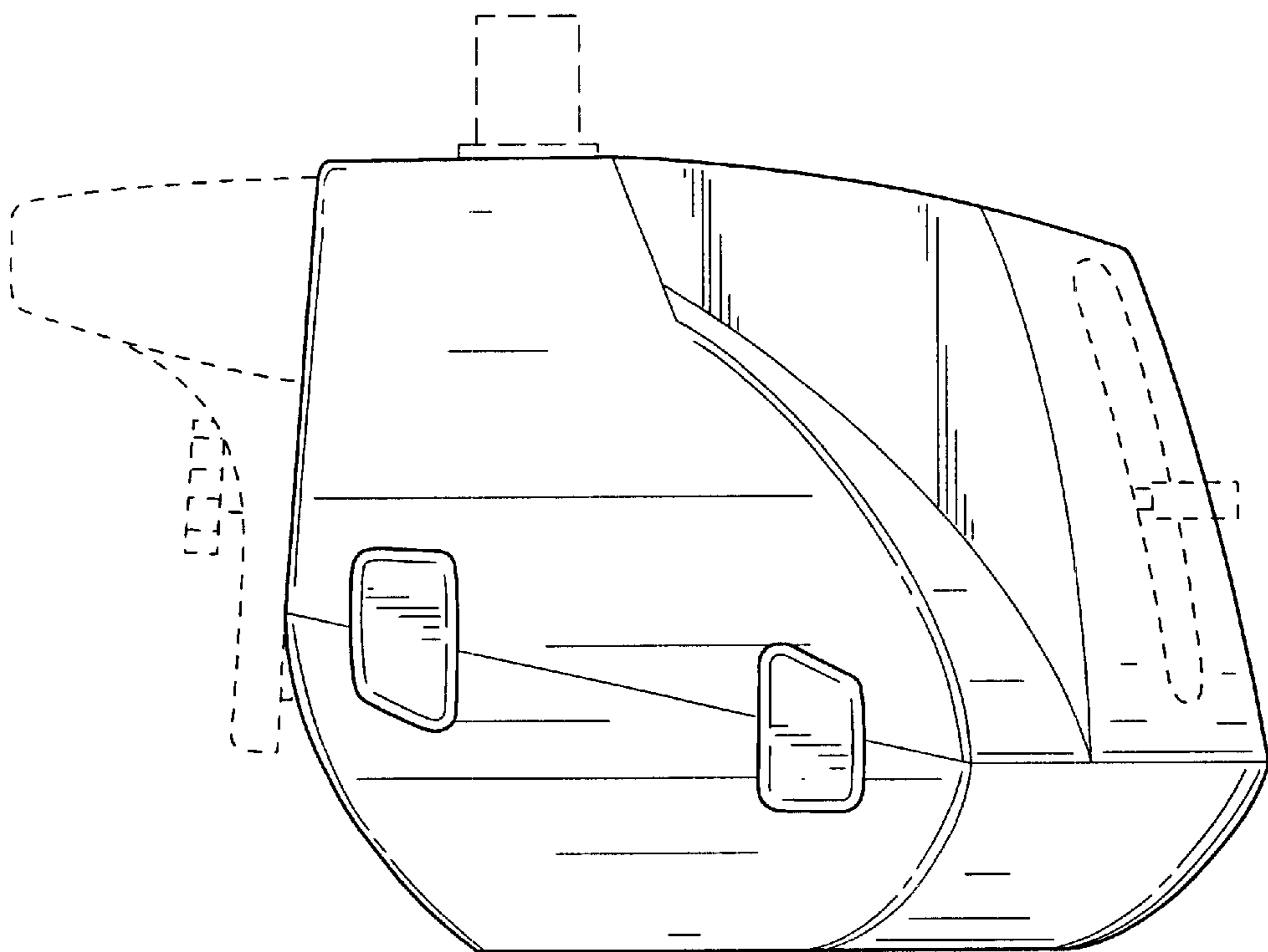

FIG. 12

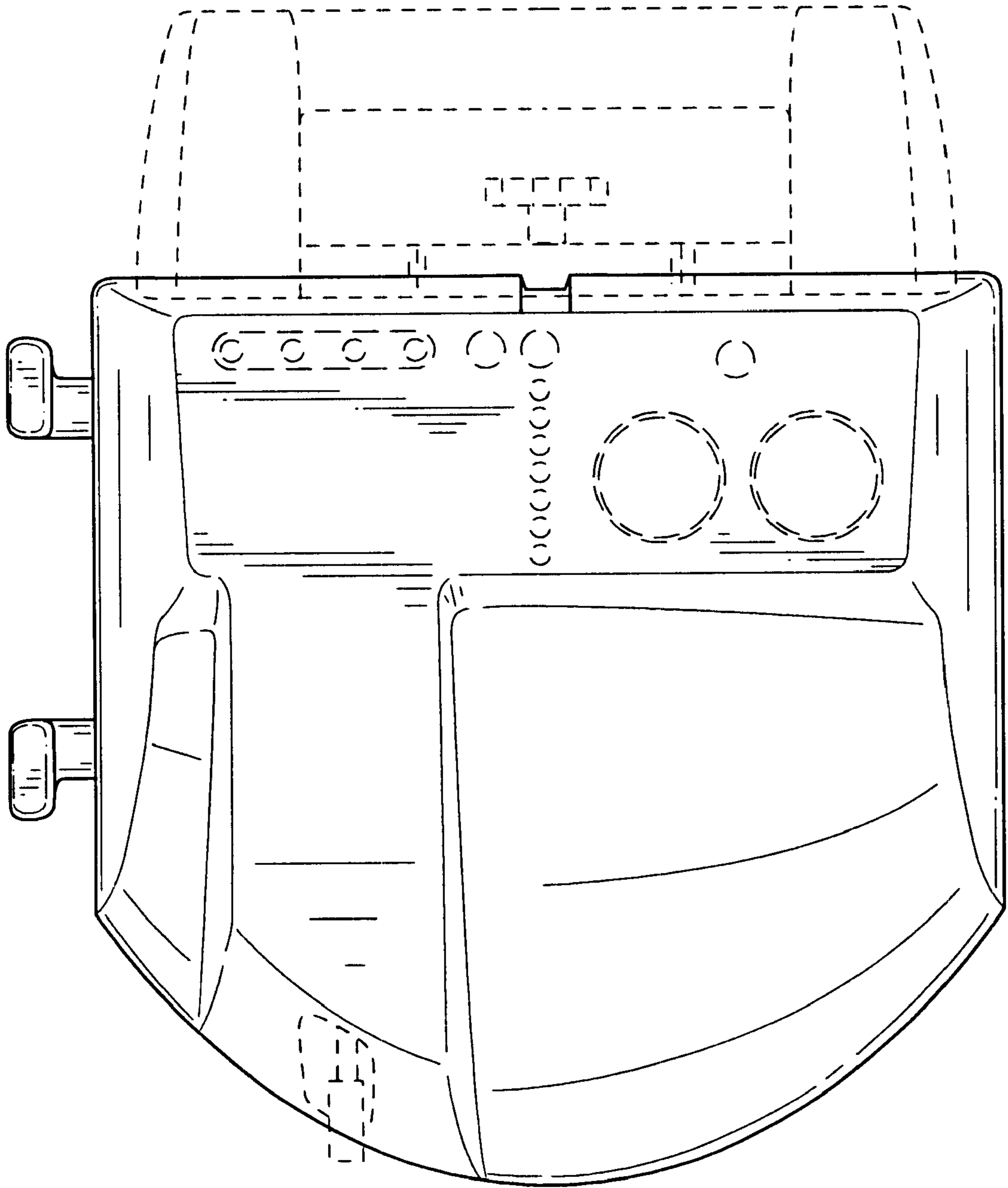

FIG.13

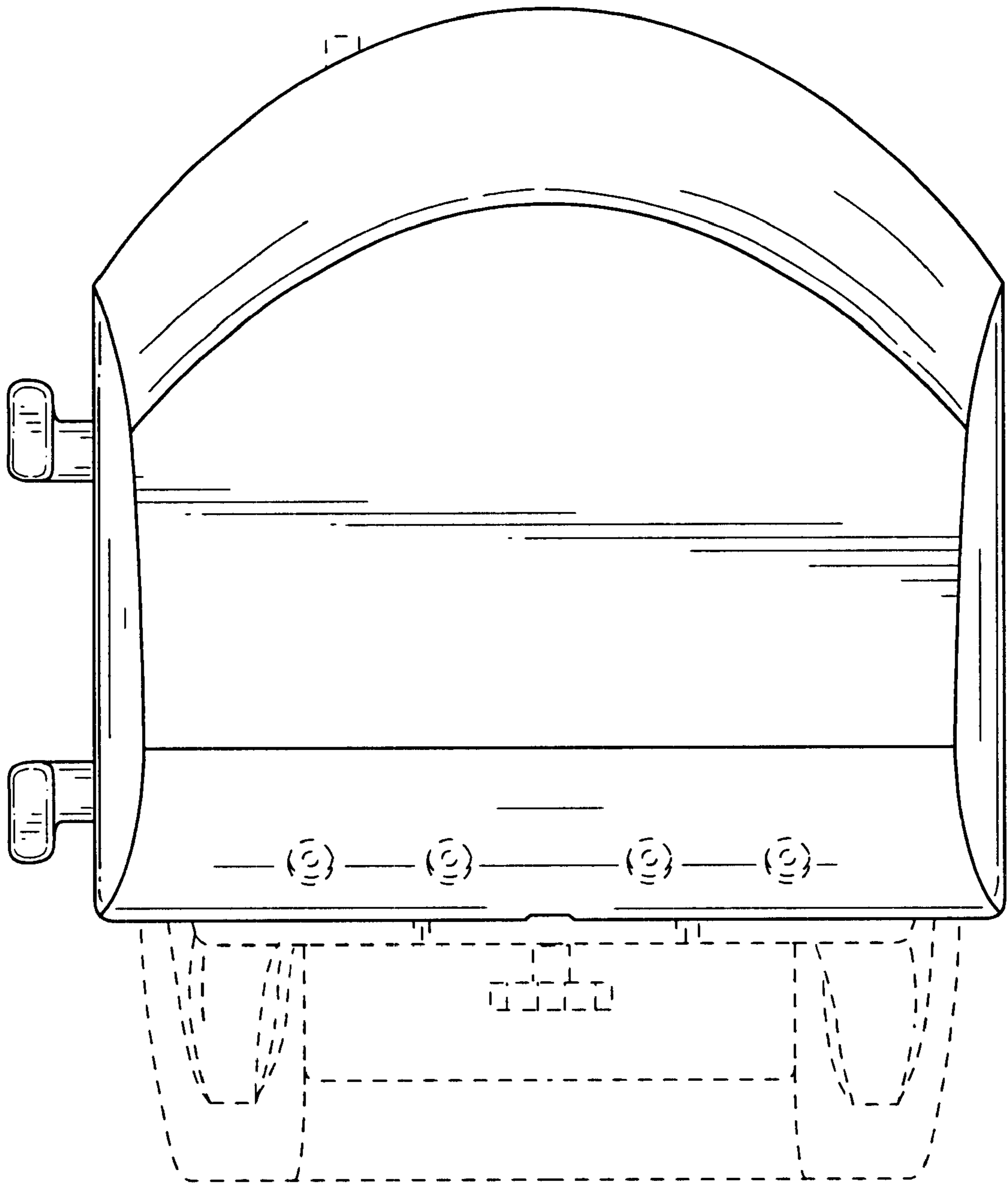

FIG. 14

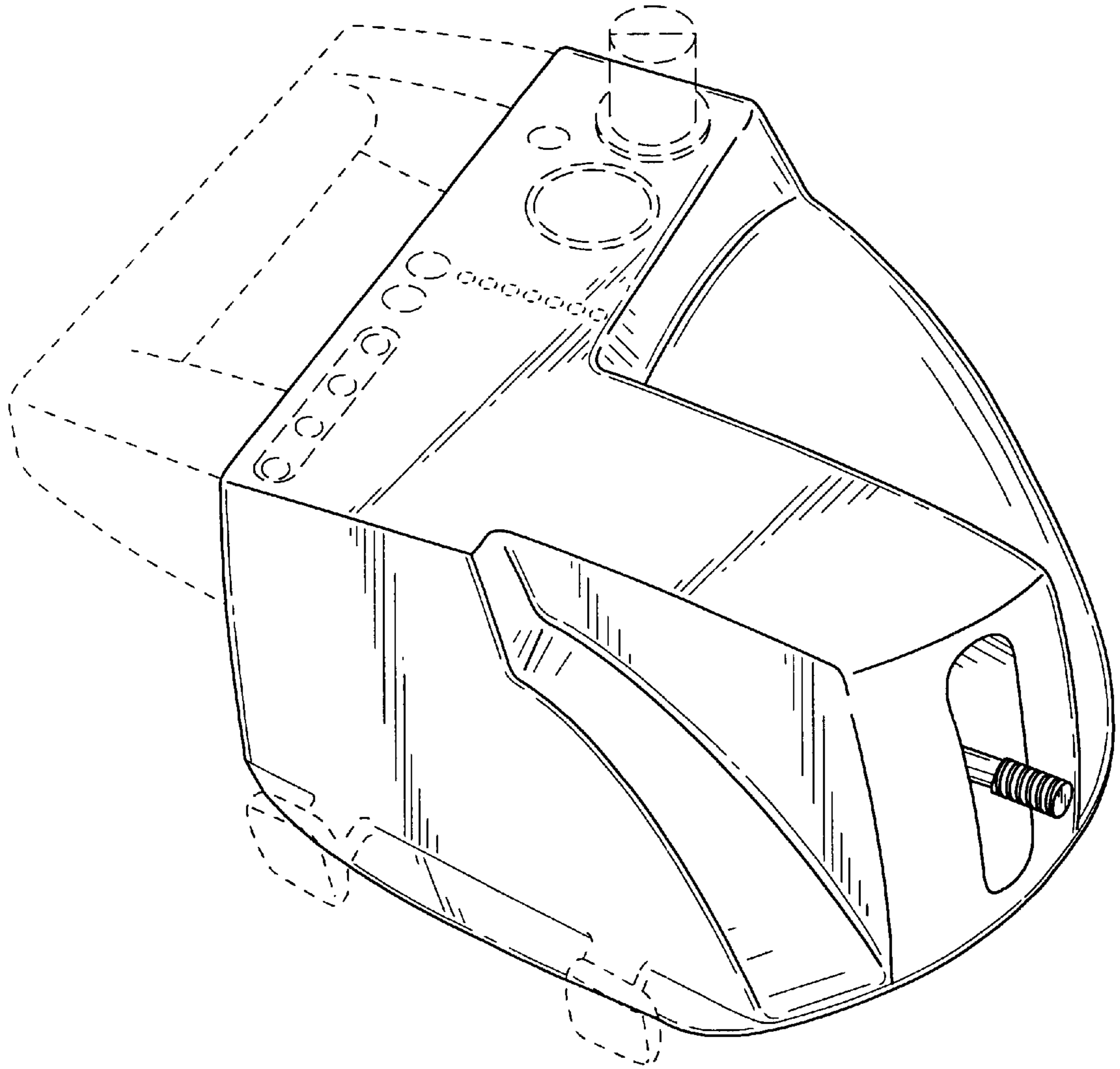

FIG.15

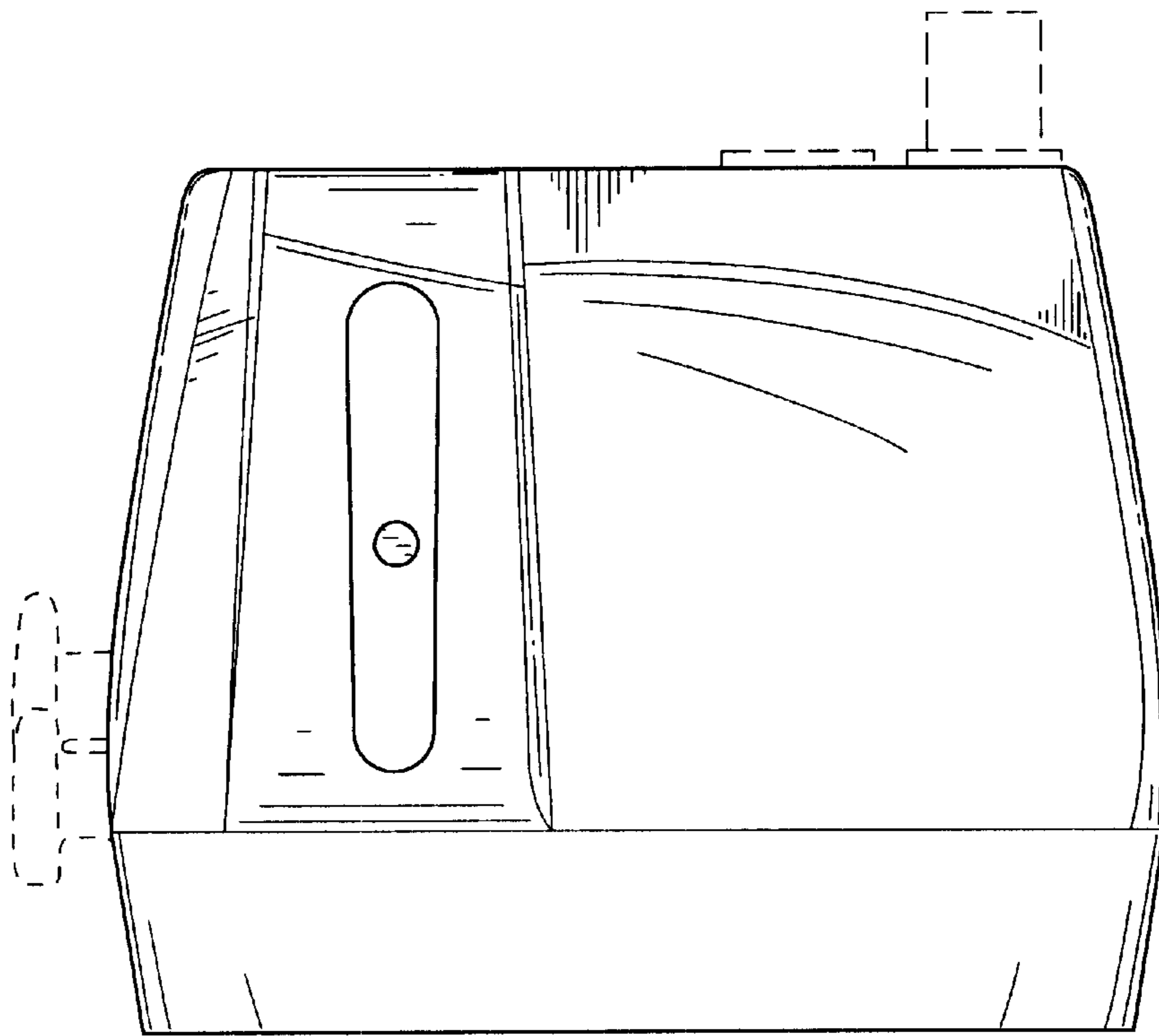

FIG. 16

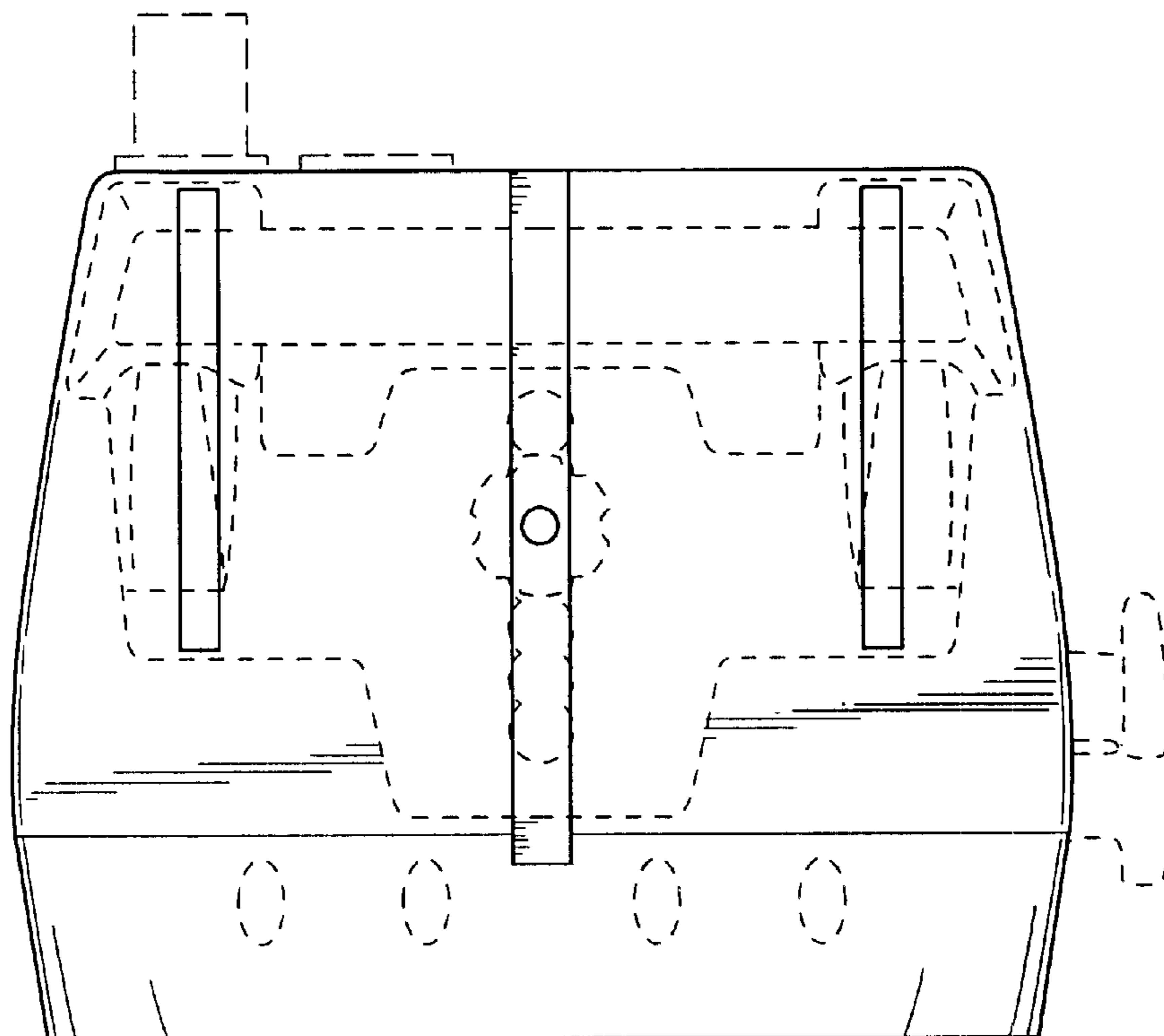

FIG. 17

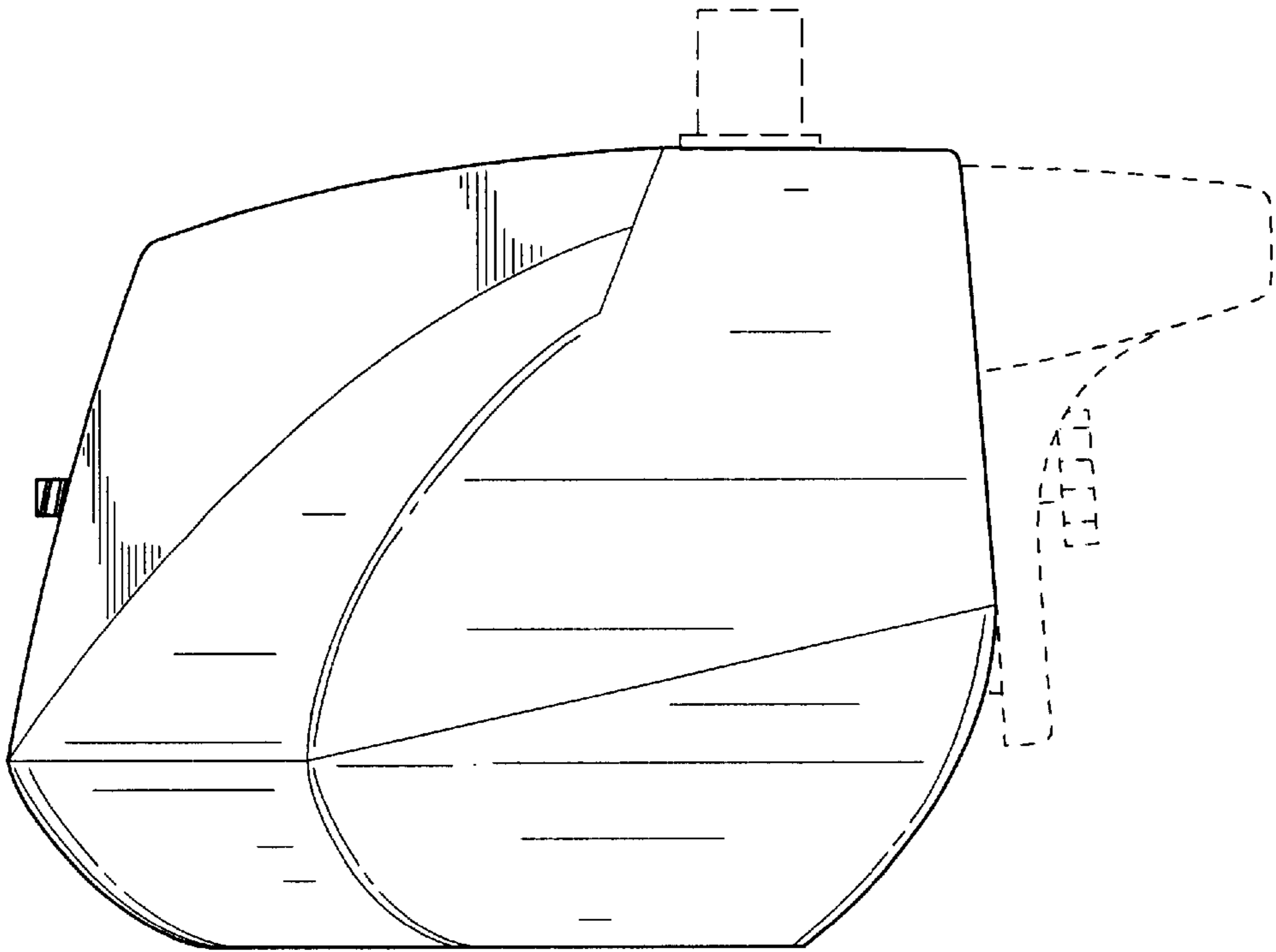

FIG. 18

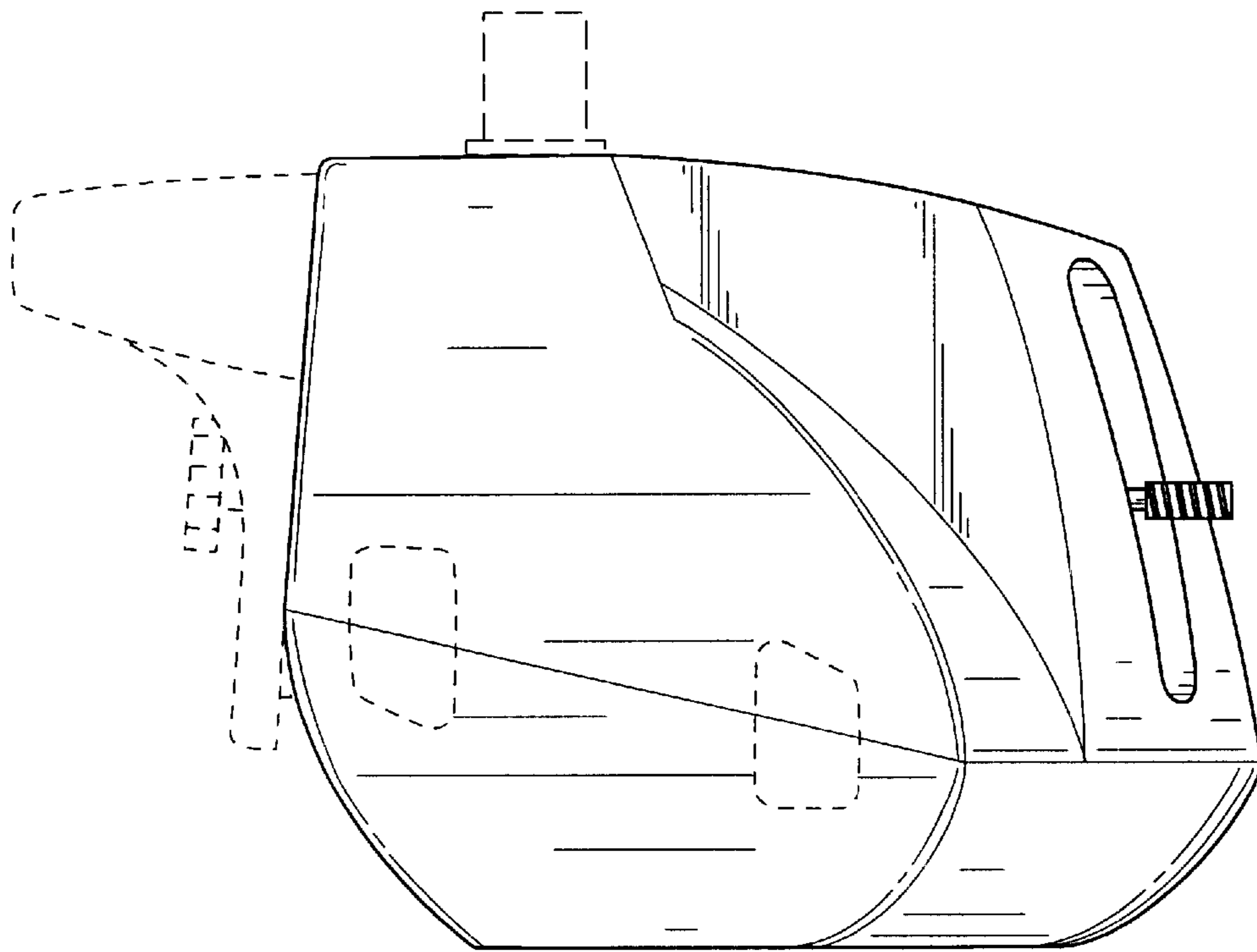

FIG. 19

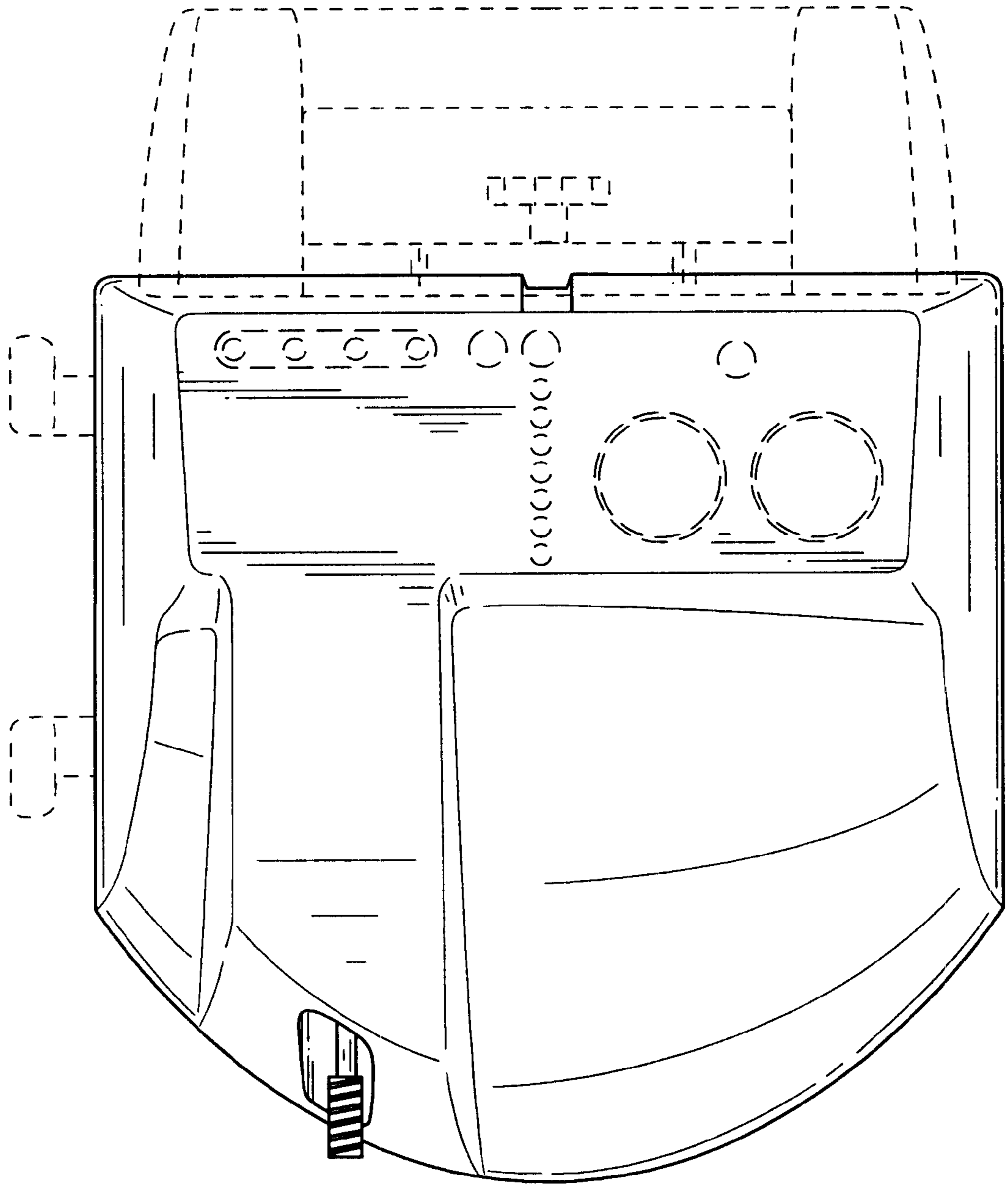

FIG.20



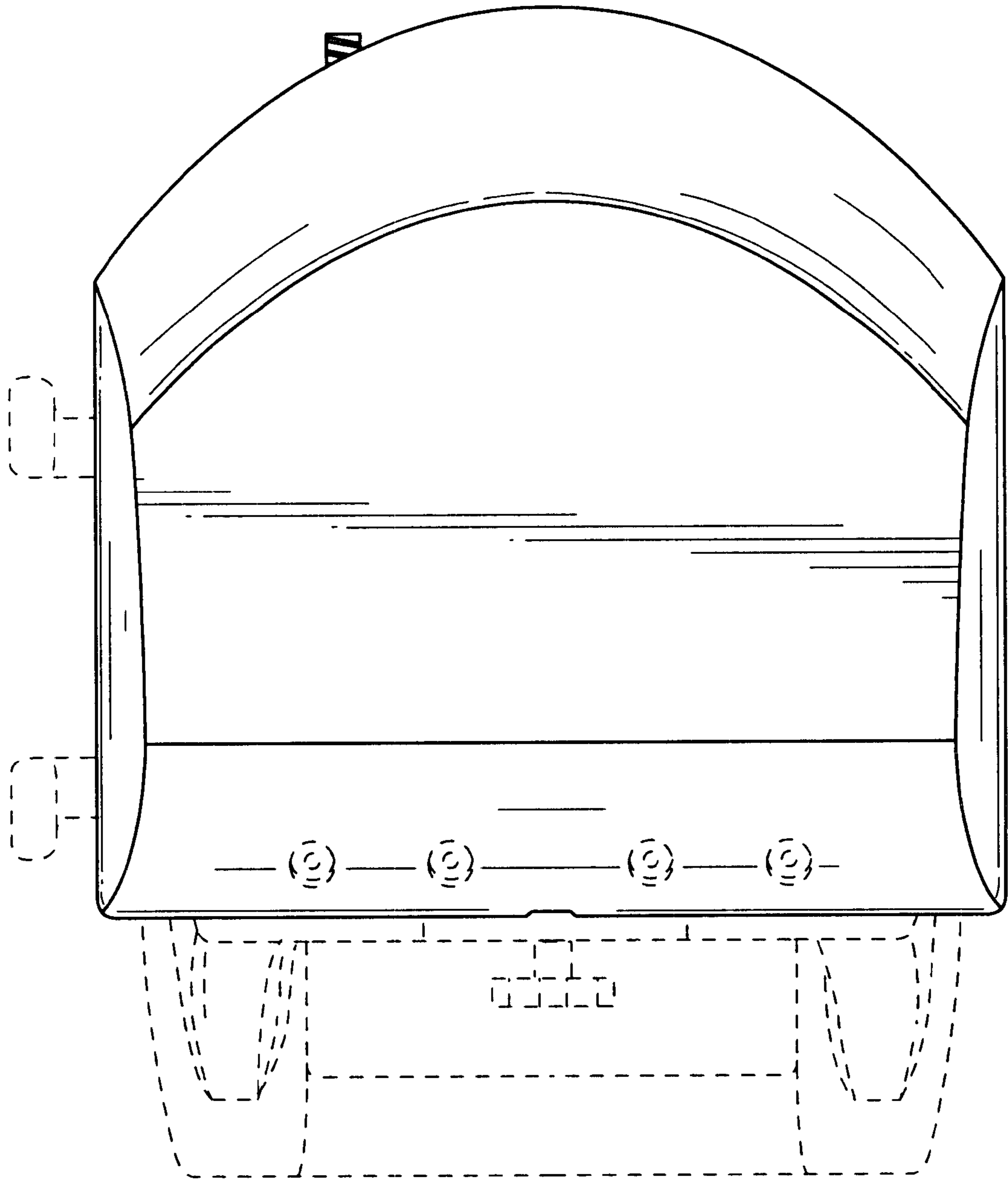

FIG.21

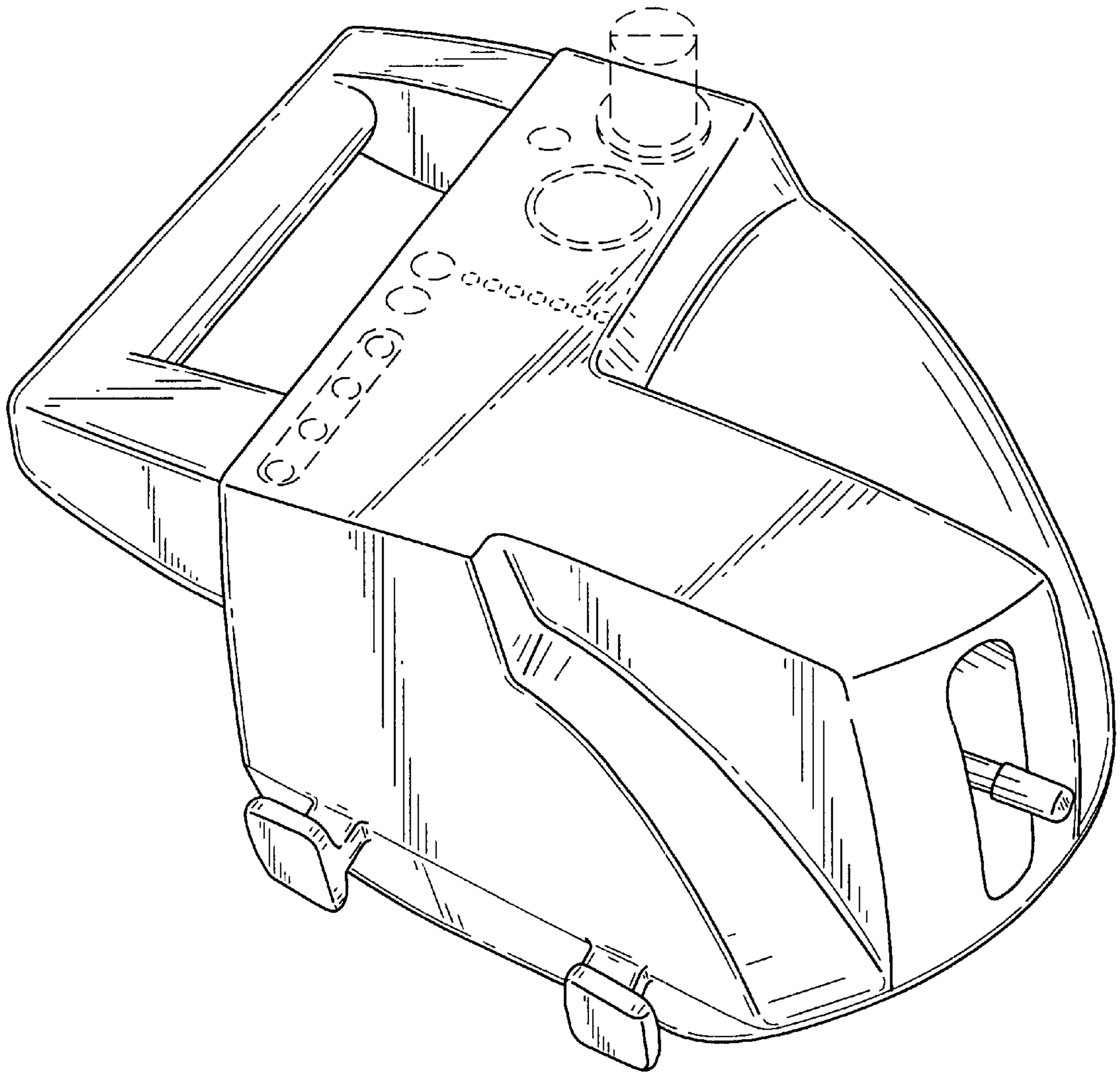

FIG.22

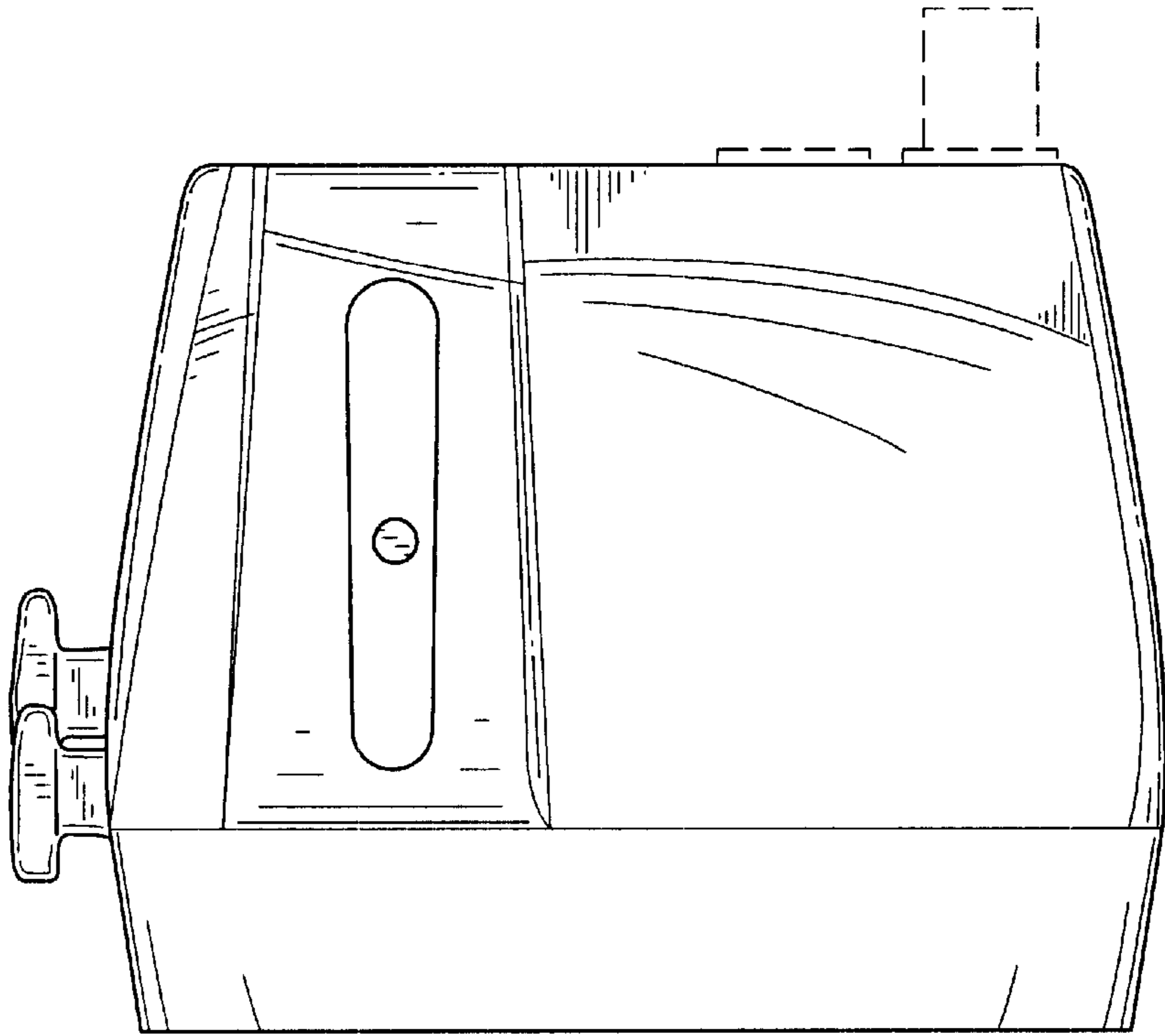

FIG. 23

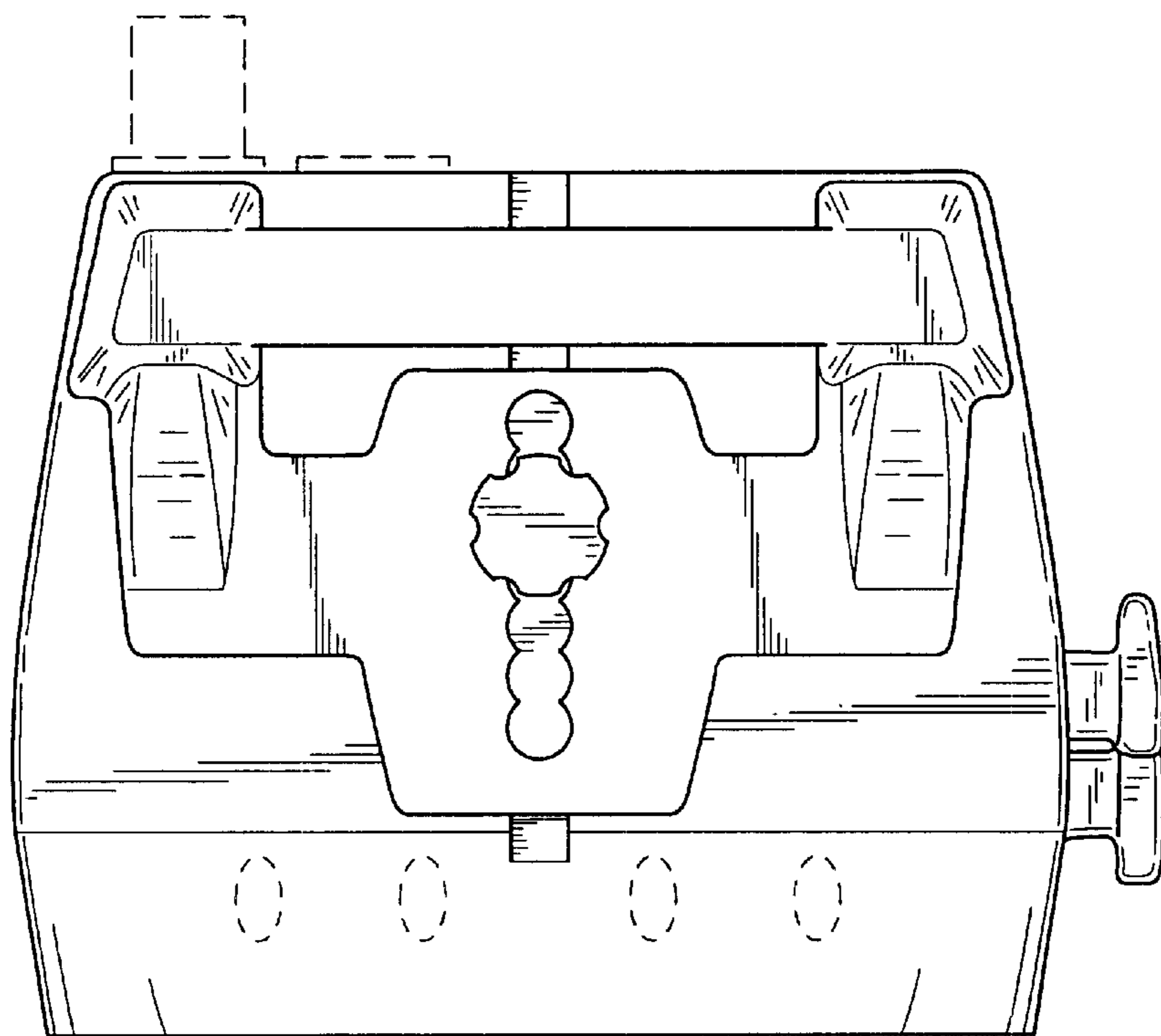

FIG. 24

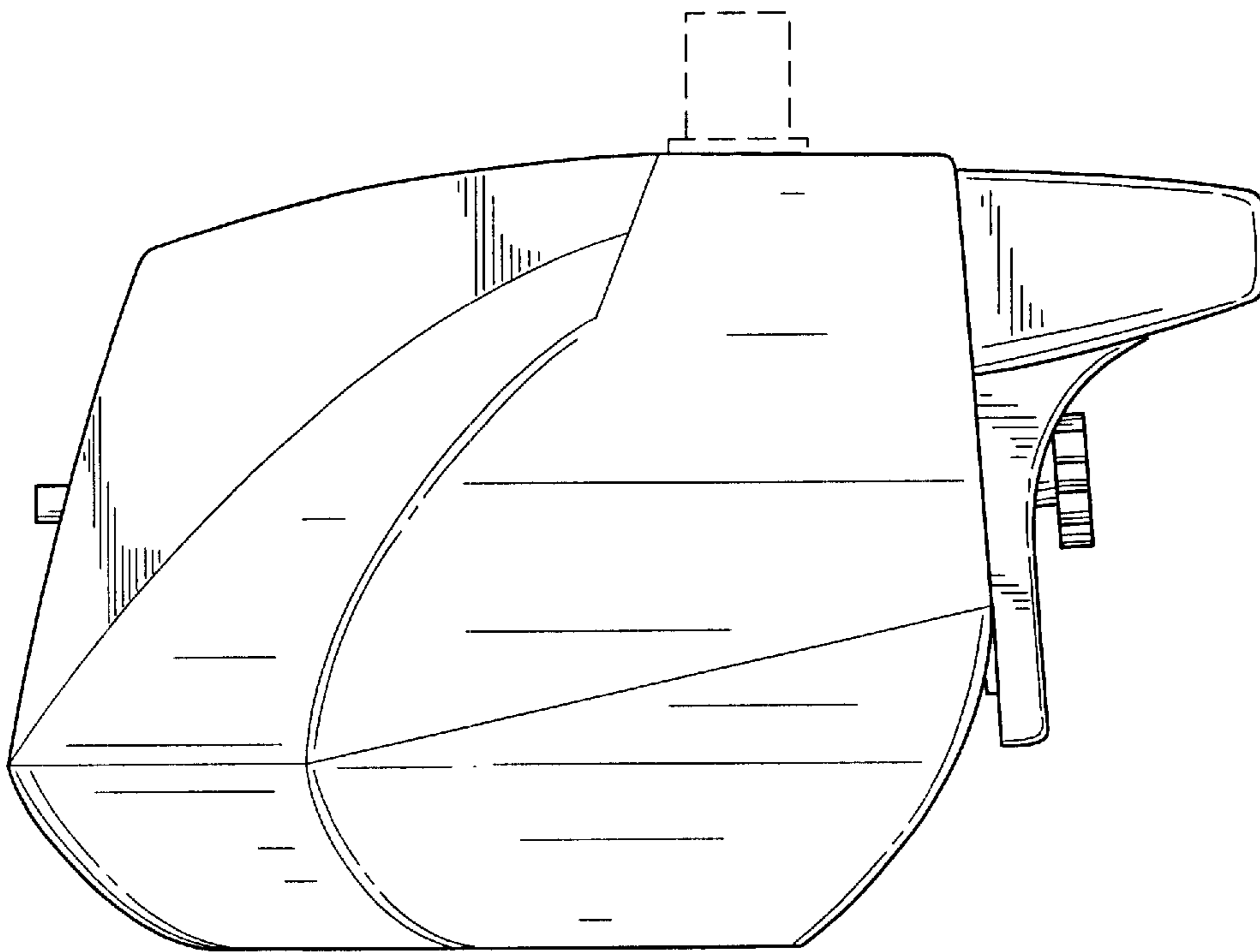

FIG.25

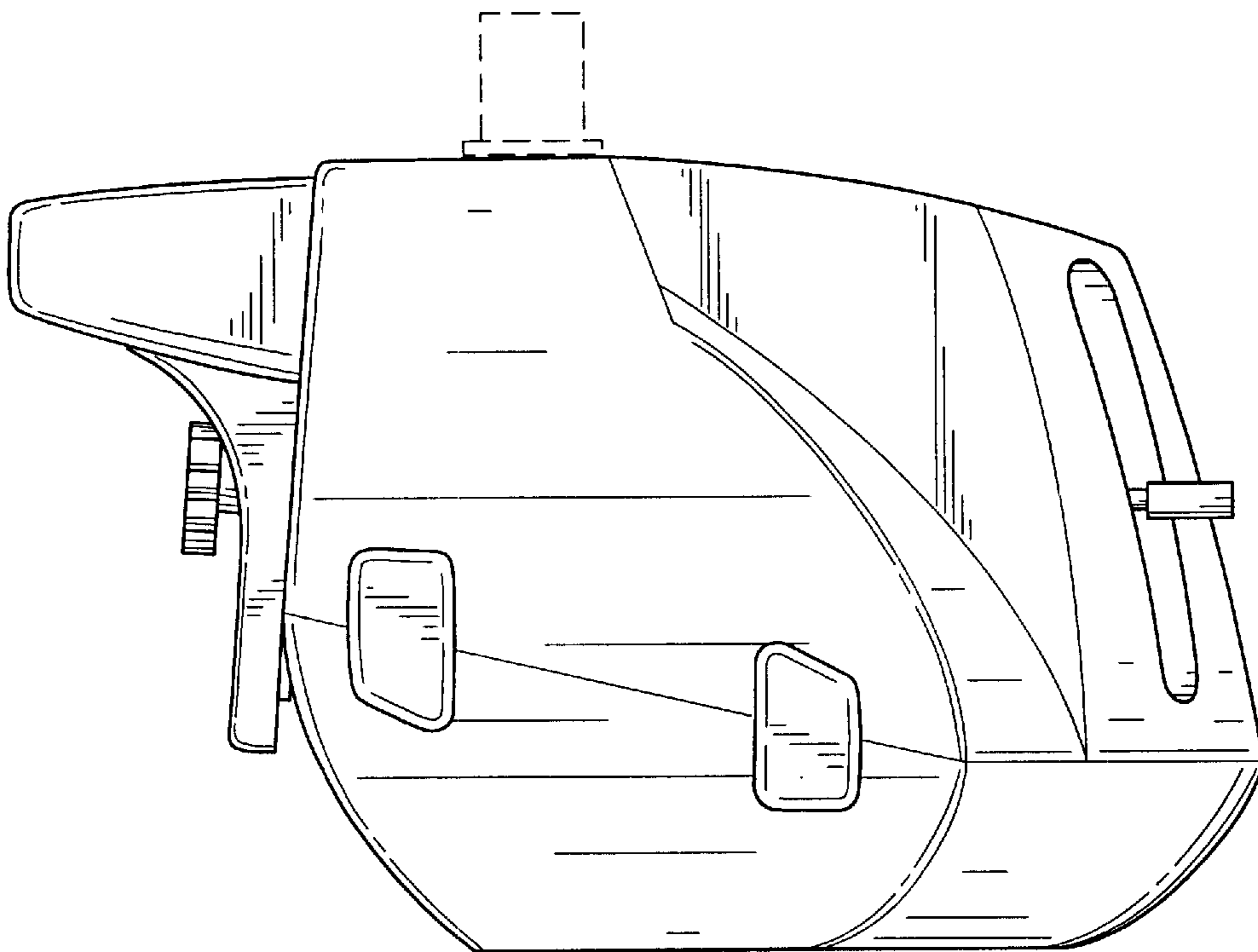

FIG.26

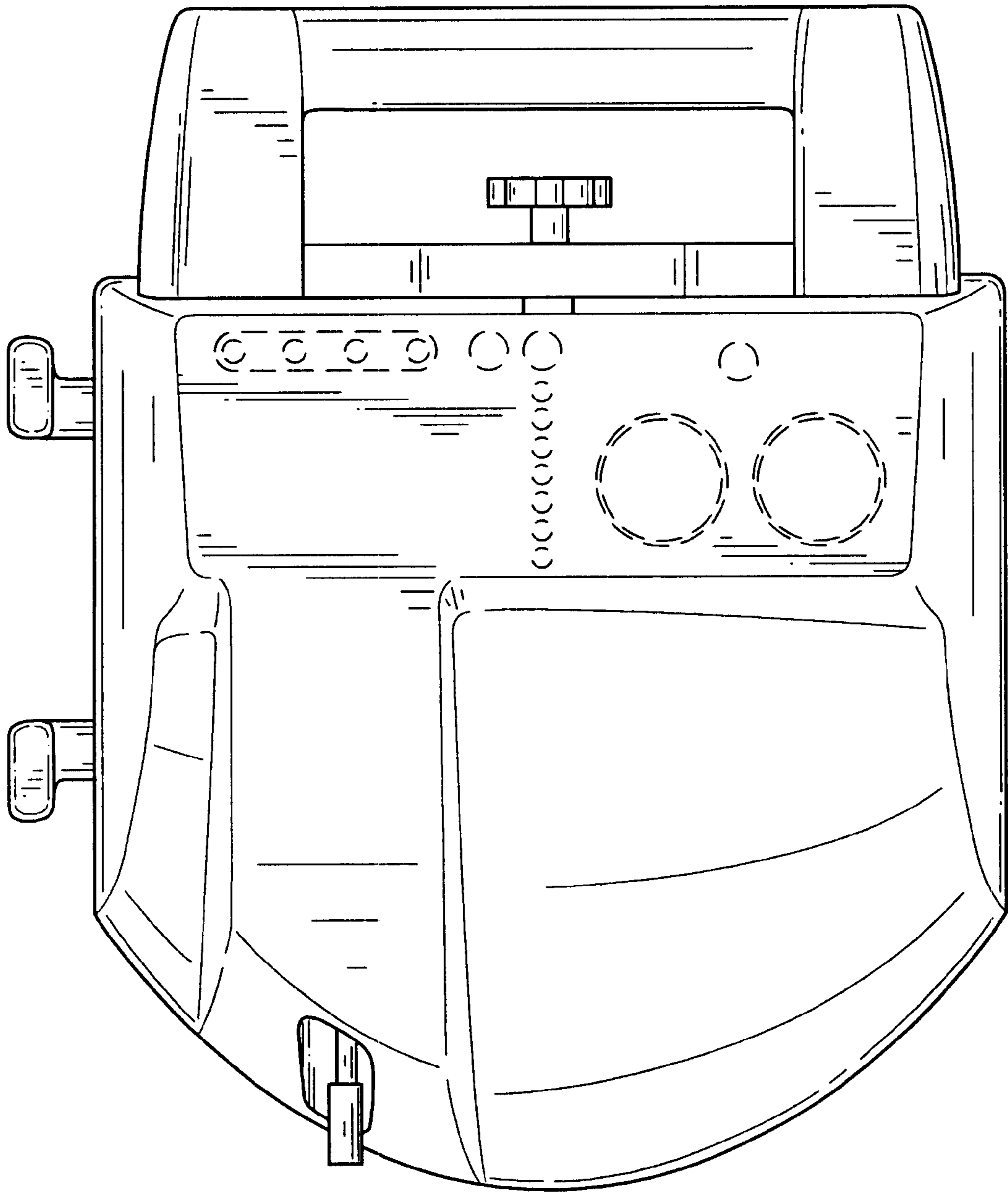

FIG.27

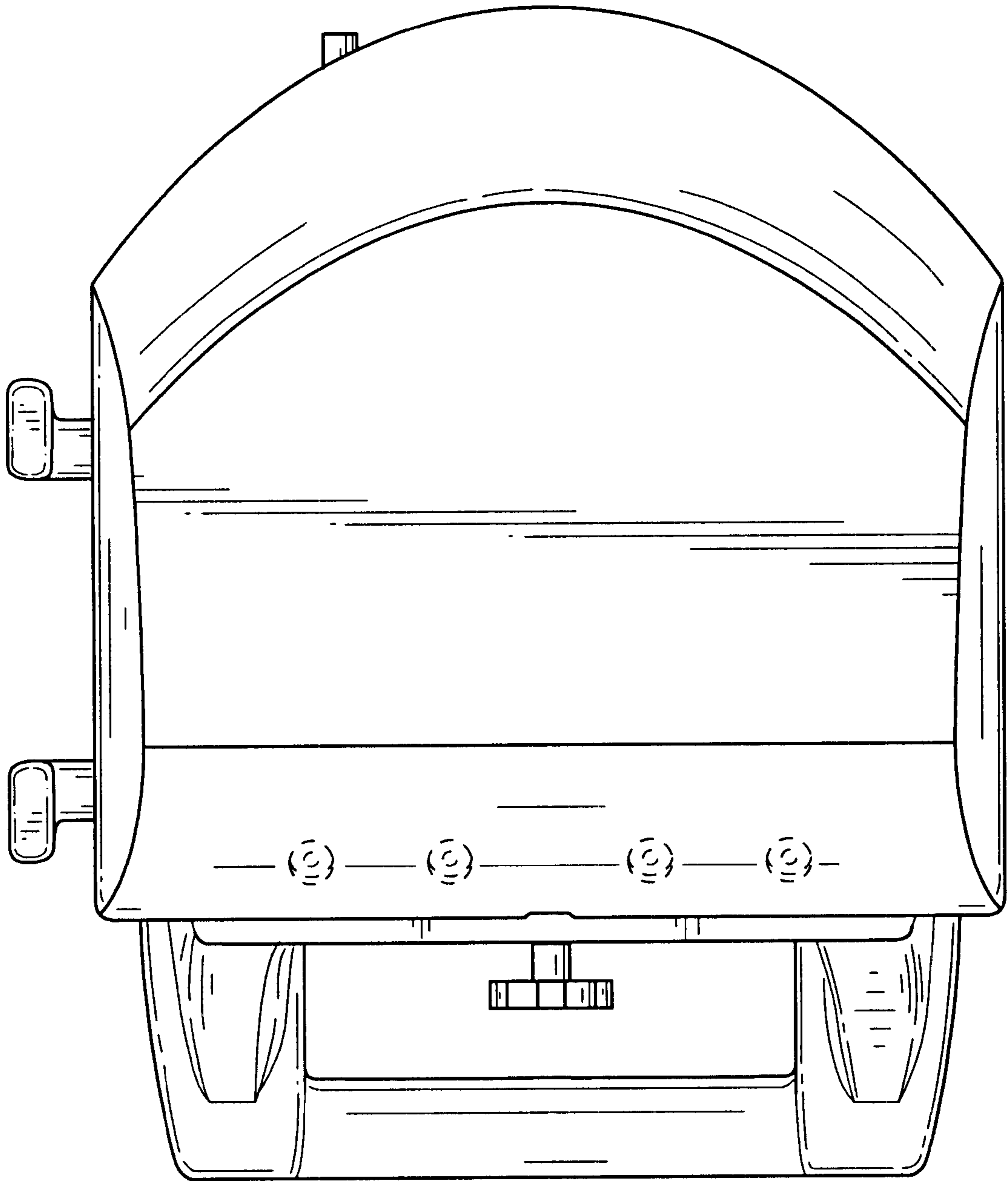

FIG.28

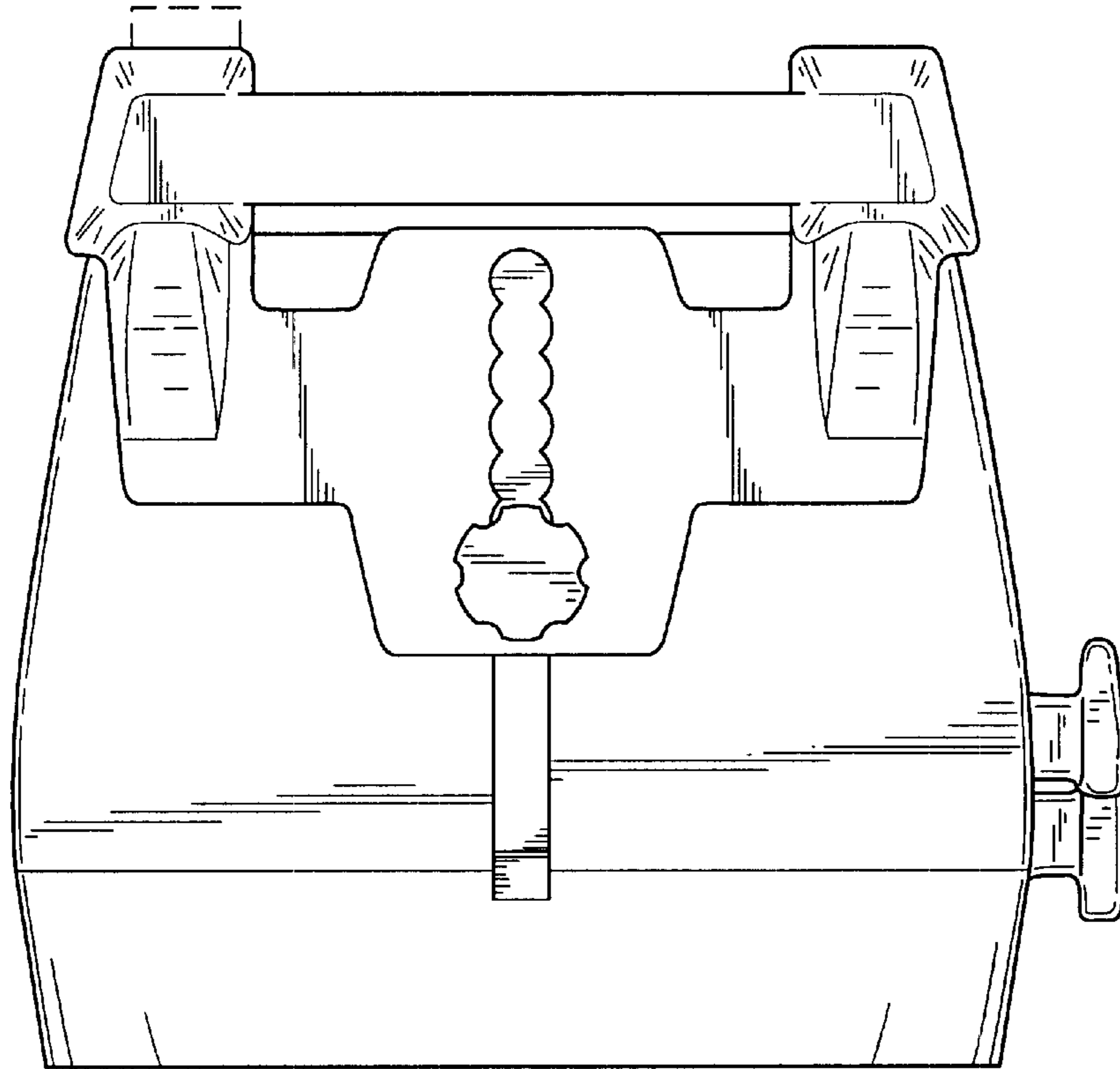

FIG. 29

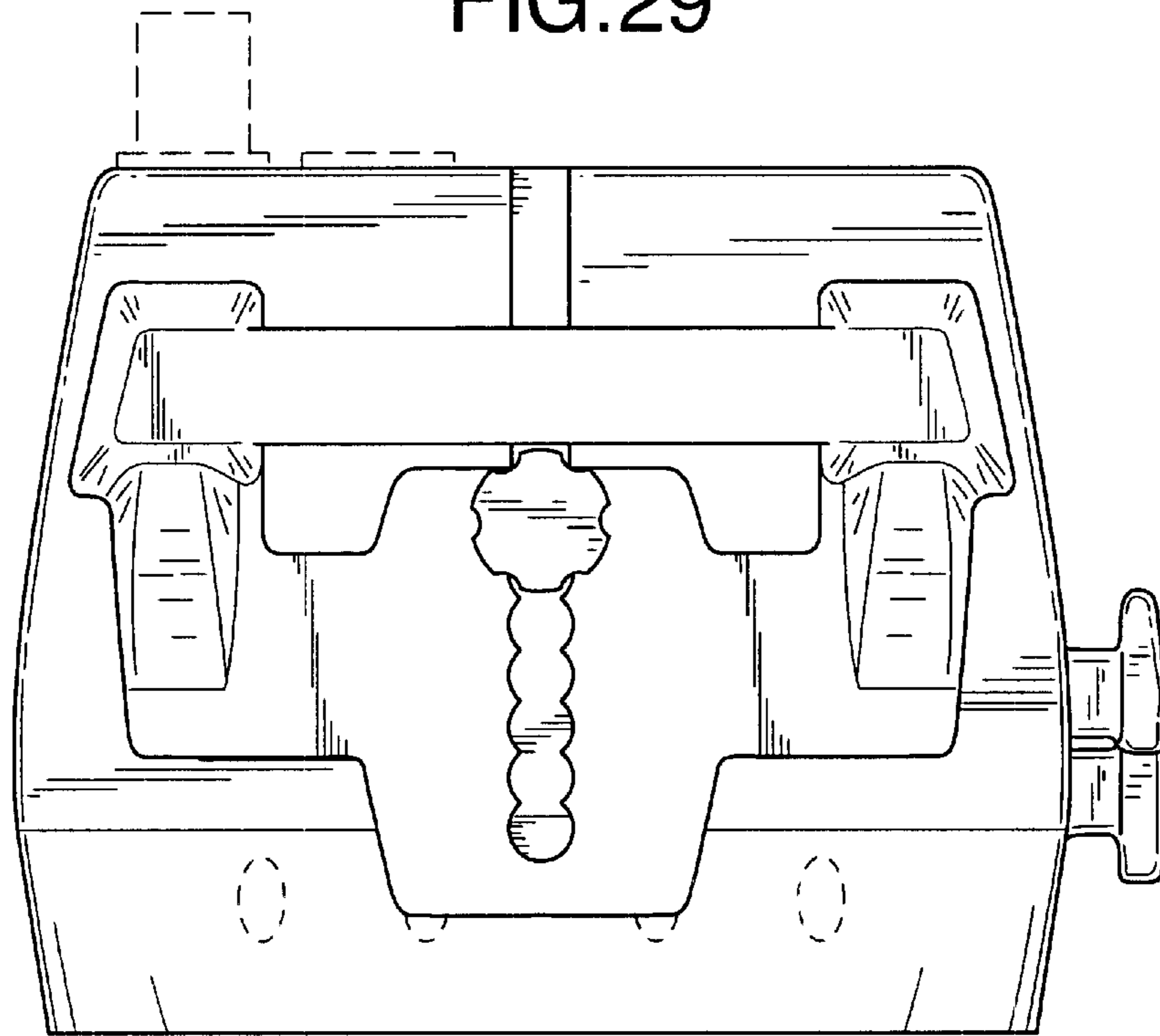

FIG. 30

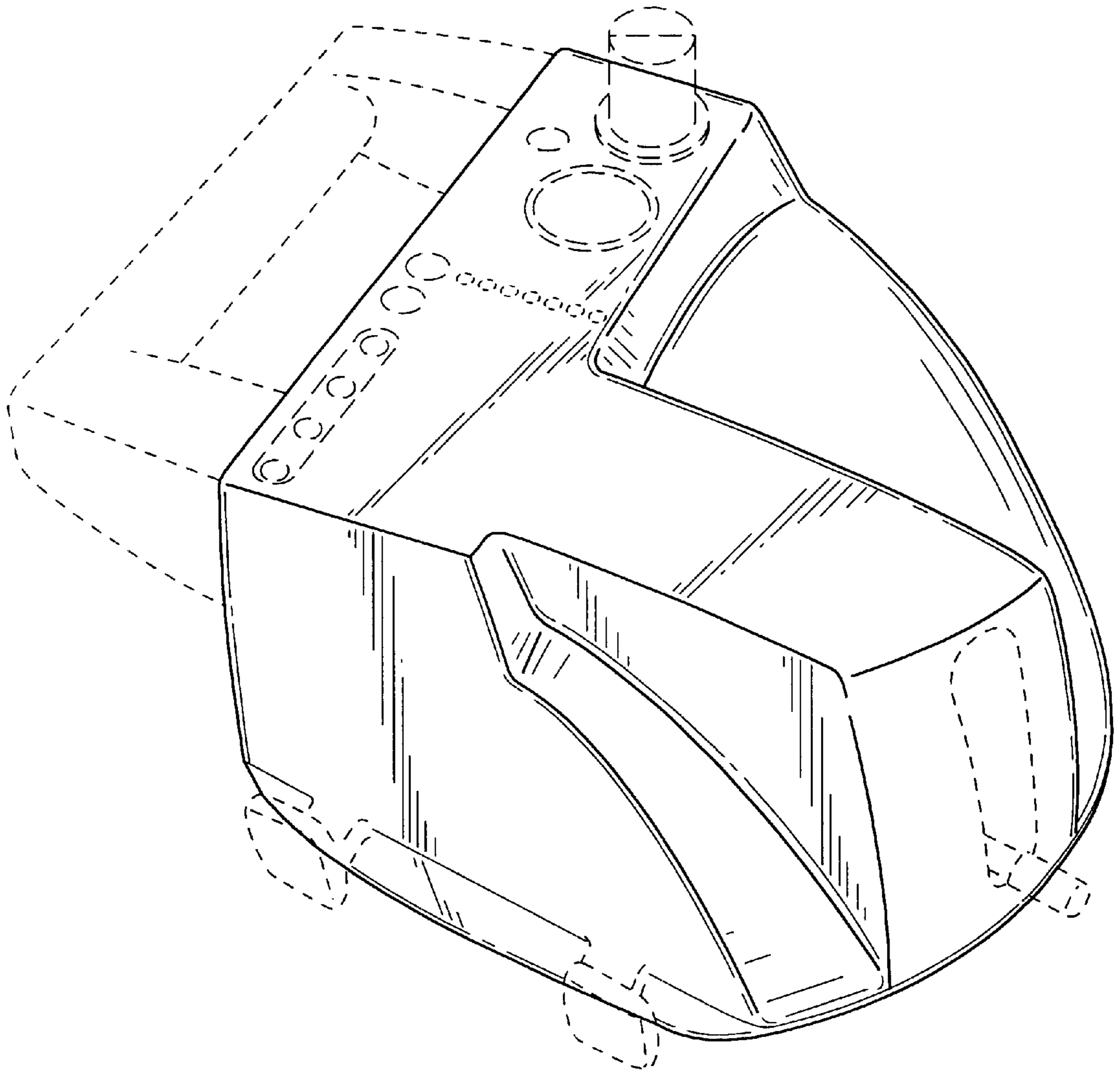

FIG.31



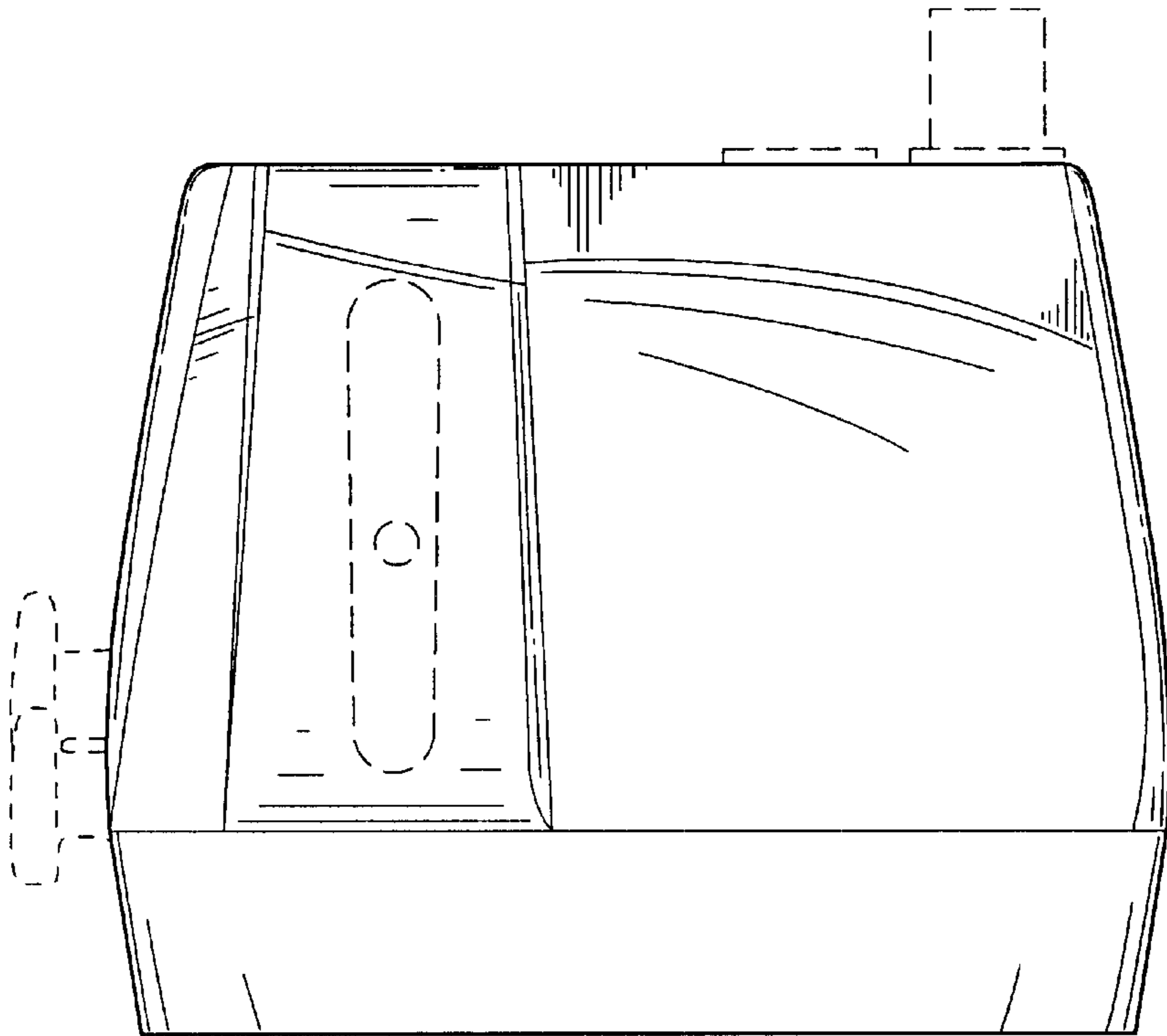

FIG.32

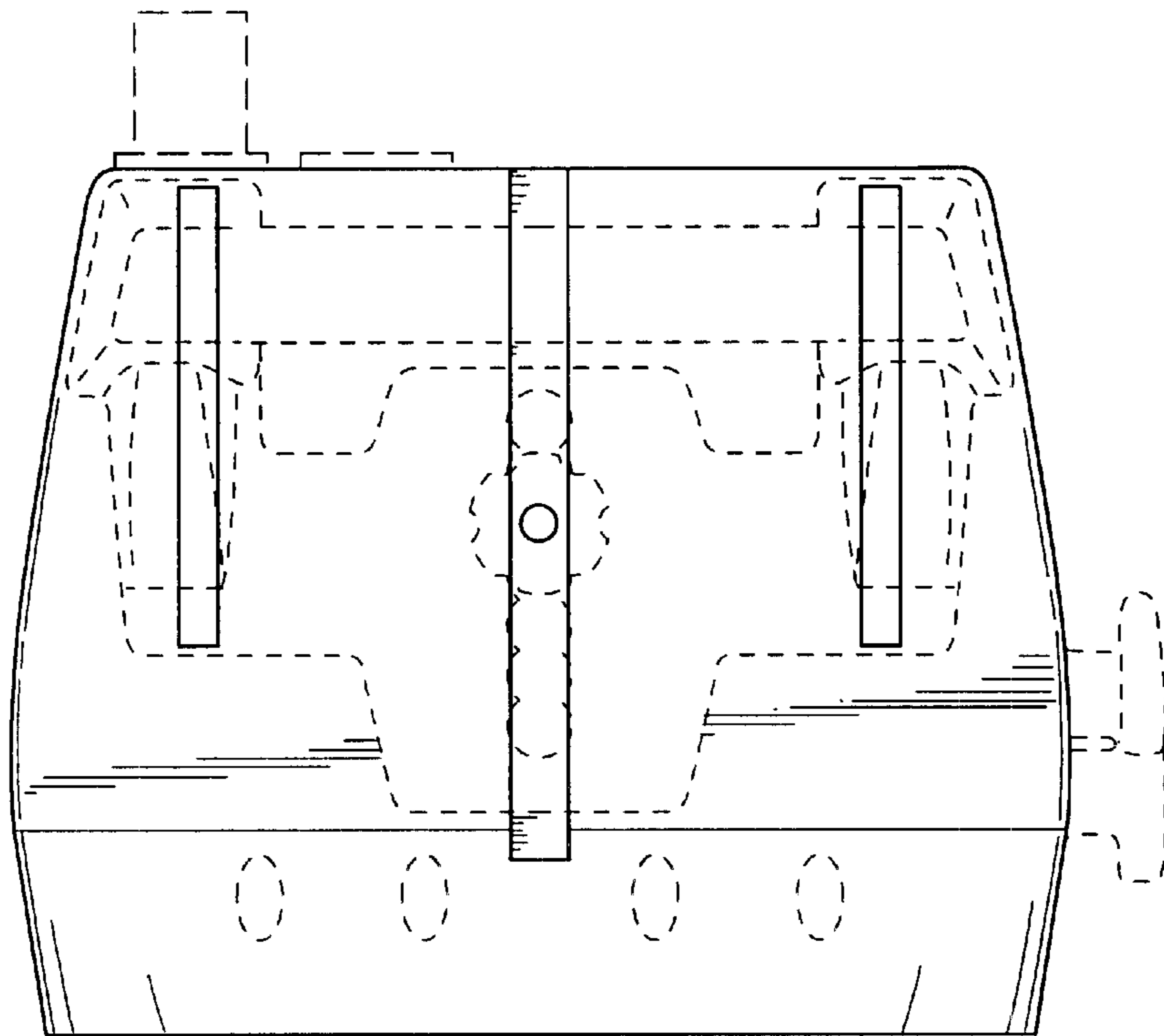

FIG.33

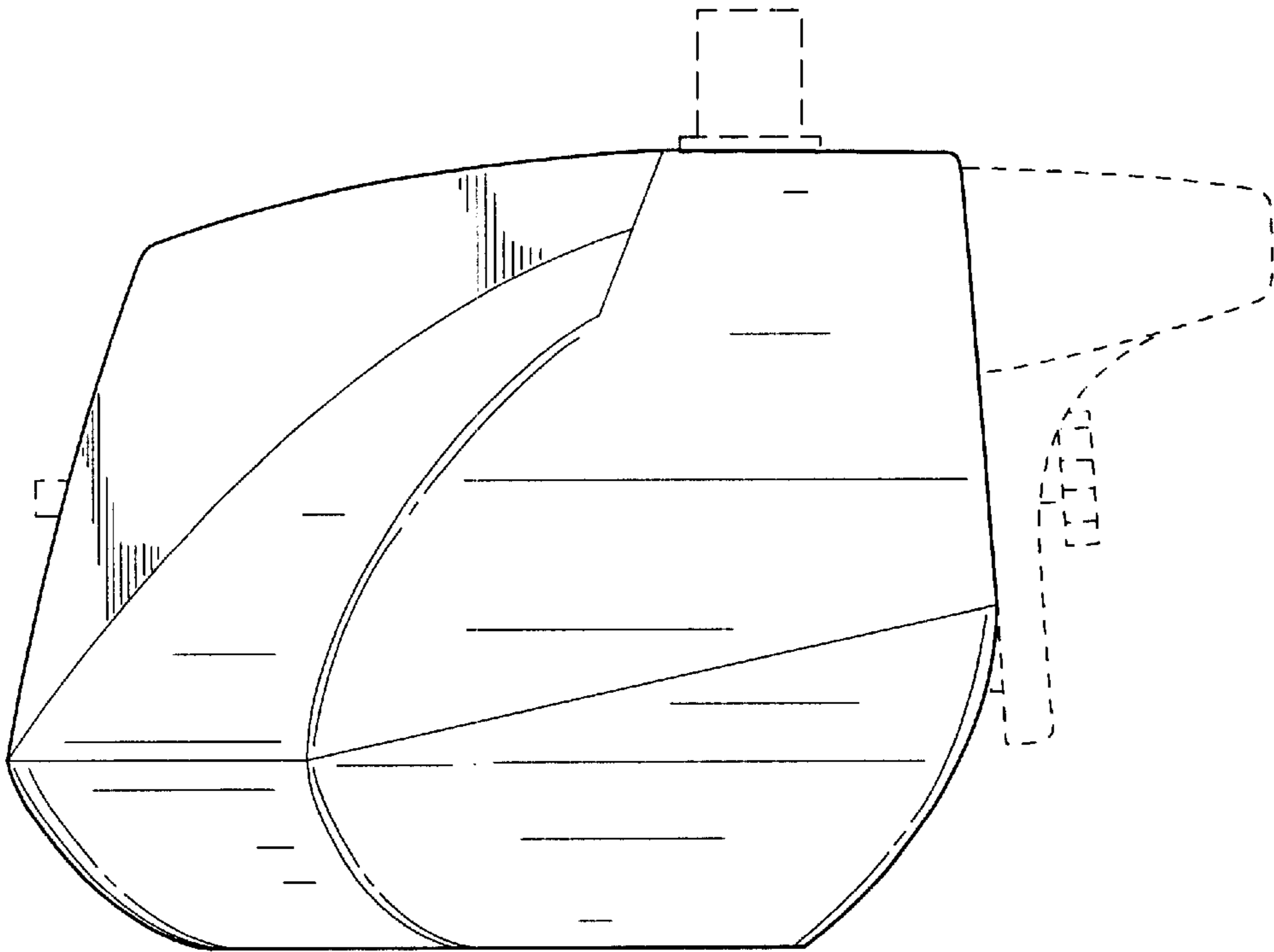

FIG. 34

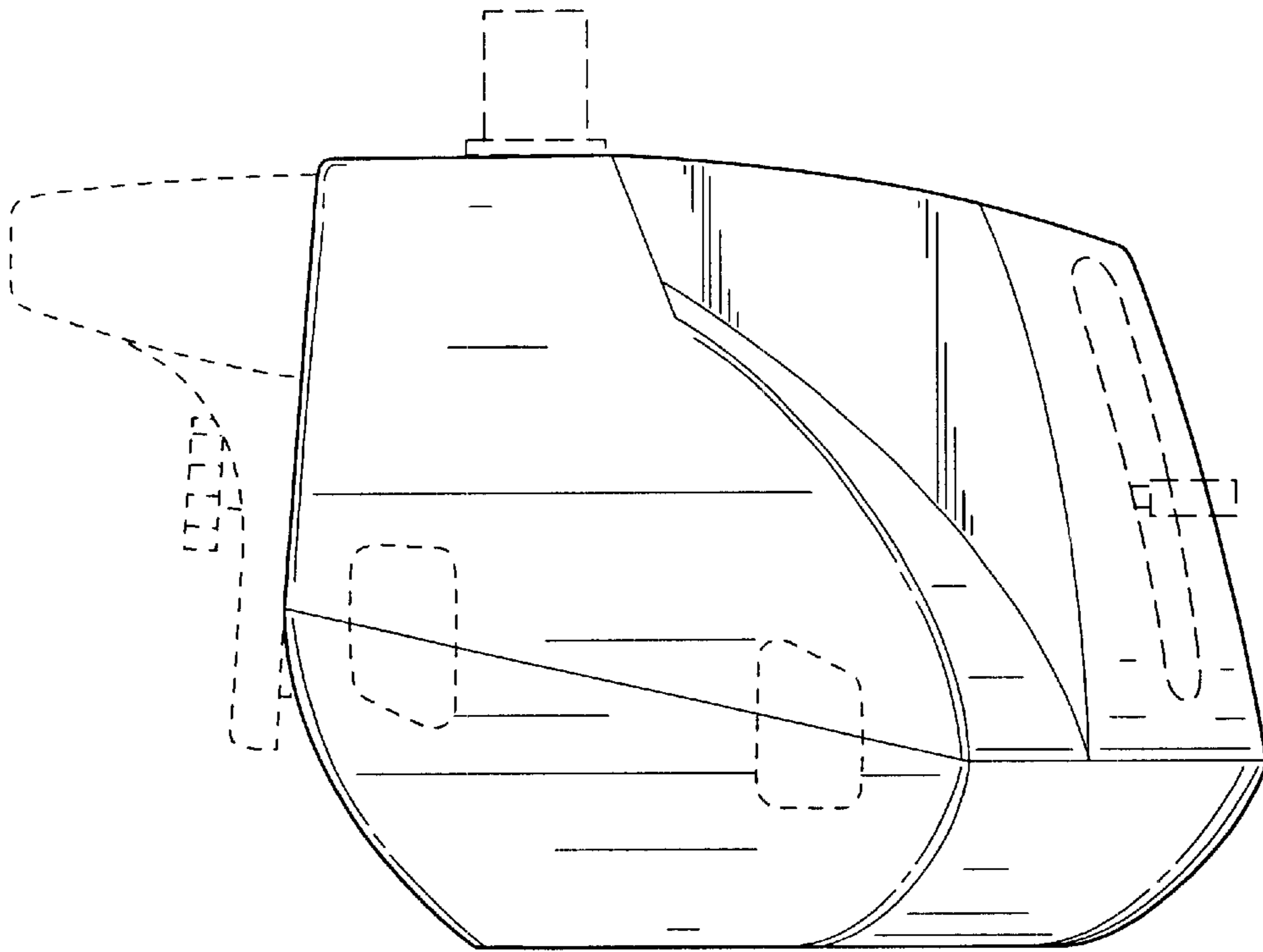

FIG. 35

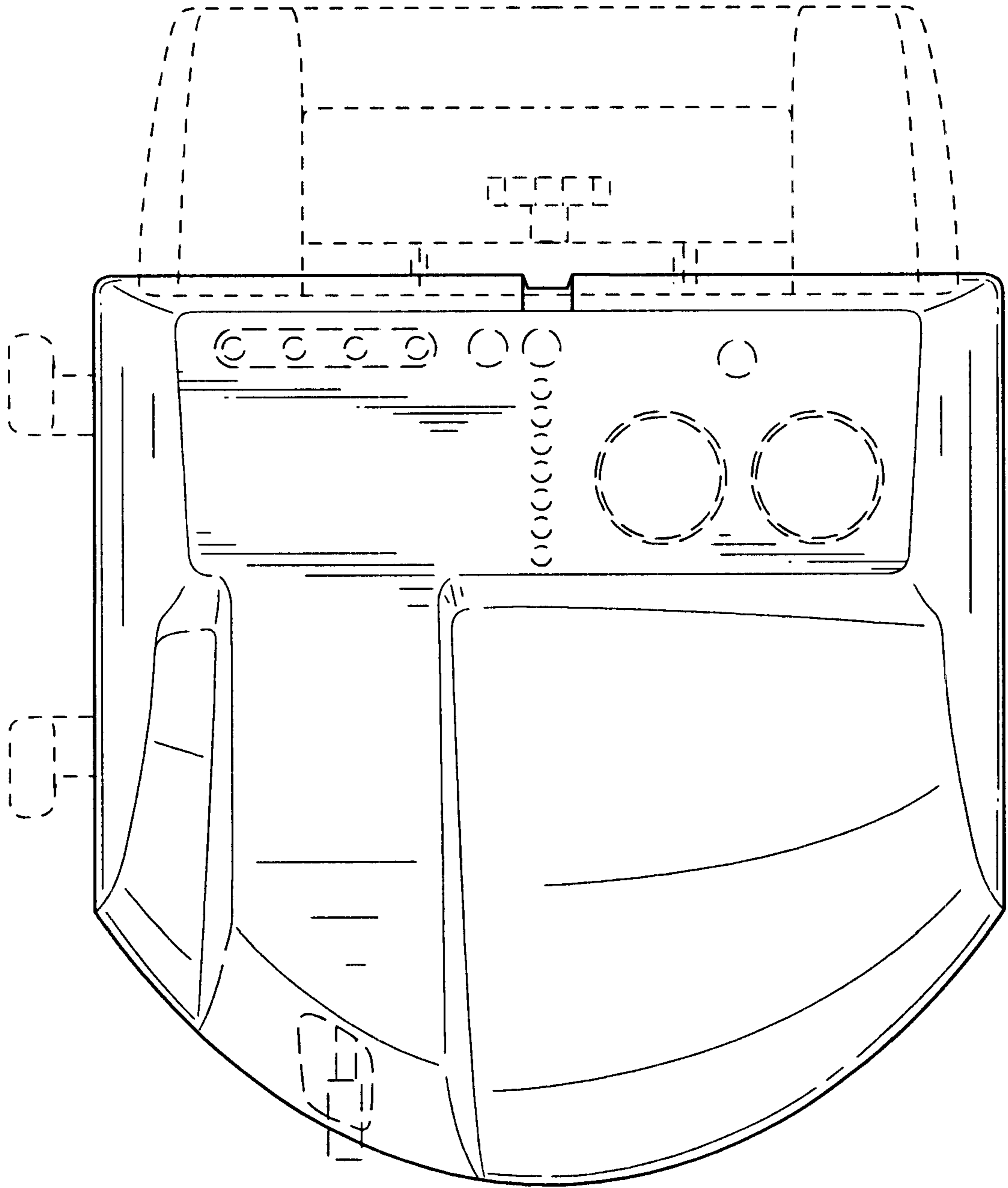

FIG.36

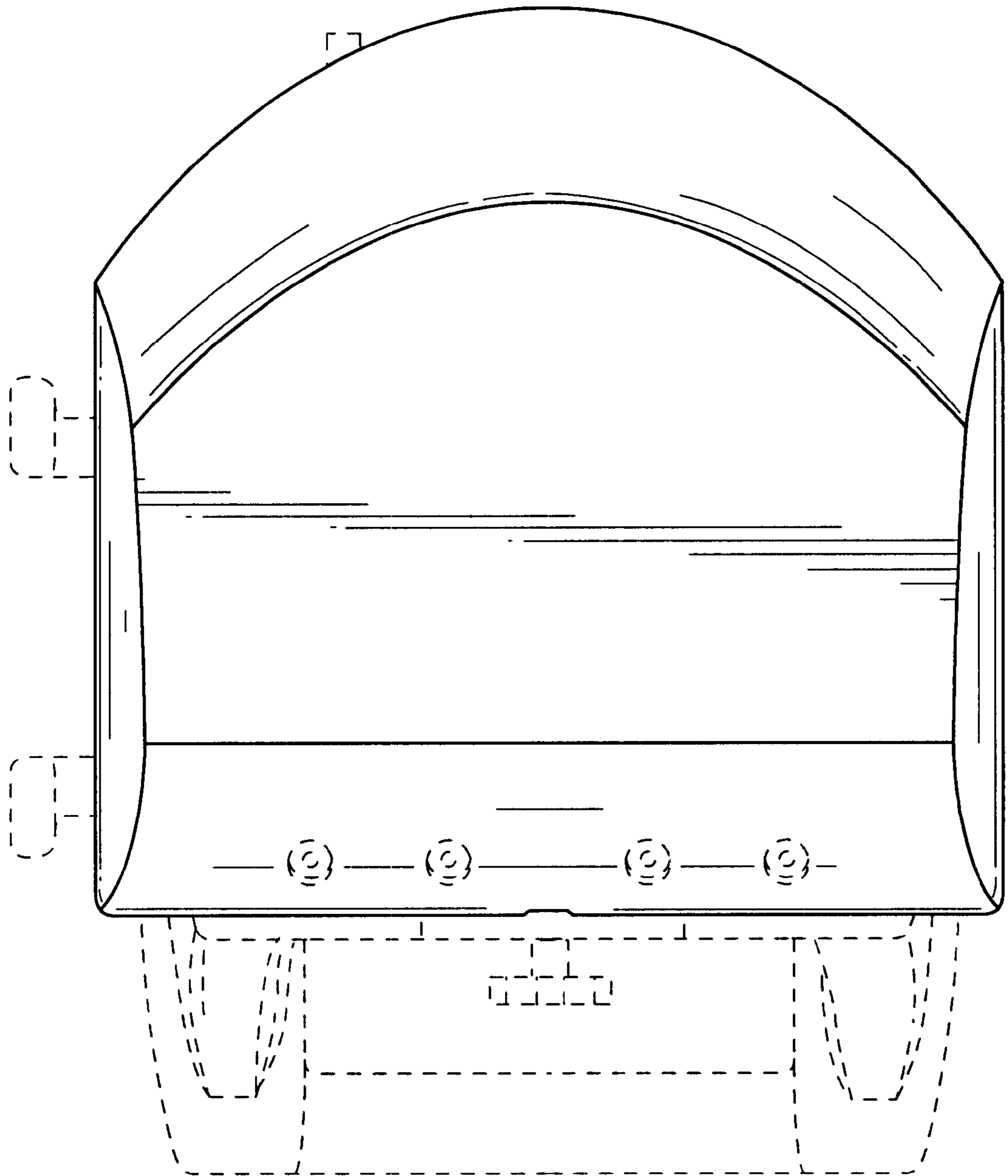

FIG.37

**UNITED STATES PATENT AND TRADEMARK OFFICE**  
**Certificate**

Patent No. D 477,553 S

Patented: July 22, 2003

On petition requesting issuance of a certificate for correction of inventorship pursuant to 35 U.S.C. 256, it has been found that the above identified patent, through error and without any deceptive intent, improperly sets forth the inventorship.

Accordingly, it is hereby certified that the correct inventorship of this patent is: Alec D. Brock, Colorado Springs, CO; Daniel L. Decker, Jr., Castle Rock, CO; Nathan R. Mortensen, Bethoud, CO; Jeffery T. Samson, Boulder, CO; and Eric M. Homan, Corte Madera, CA.

Signed and Sealed this Thirteenth Day of December 2005.

ALAN P. DOUGLAS  
*Supervisory Patent Examiner*  
Art Unit 2911