



US00D477428S

(12) **United States Design Patent**  
**Hill et al.**

(10) **Patent No.:** **US D477,428 S**

(45) **Date of Patent:** **\*\* Jul. 15, 2003**

(54) **HEADLIGHT**

(75) Inventors: **Thomas Chilton Hill**, West Bend, WI (US); **James Heinrich Weitz**, Hoboken, NJ (US); **Alberto Mantilla**, Rego Park, NY (US)

(73) Assignee: **Deere & Company**, Moline, IL (US)

(\*\*) Term: **14 Years**

(21) Appl. No.: **29/166,732**

(22) Filed: **Aug. 30, 2002**

(51) **LOC (7) Cl.** ..... **26-04**

(52) **U.S. Cl.** ..... **D26/28**

(58) **Field of Search** ..... D26/28-36; 362/61, 362/62, 64, 80, 81, 82, 83, 84

(56) **References Cited**

**U.S. PATENT DOCUMENTS**

D154,925 S	*	8/1949	Ingle	.....	D26/30
D316,696 S		5/1991	Haag et al.	.....	D12/196
D339,357 S		9/1993	Teal et al.	.....	D15/17
D343,818 S		2/1994	DeBaal et al.	.....	D12/173
D344,960 S		3/1994	Patterson et al.	.....	D15/17
D347,614 S		6/1994	DeBaal et al.	.....	D12/184
D352,723 S		11/1994	DeBaal et al.	.....	D15/31
D354,147 S	*	1/1995	Veda	.....	D26/28
5,509,710 A		4/1996	Eavenson, Sr. et al.	.....	296/19
D409,544 S		5/1999	Voss et al.	.....	D12/196
D411,330 S		6/1999	Goebert et al.	.....	D26/139
D441,469 S		5/2001	Goebert et al.	.....	D26/28
D469,193 S	*	1/2003	Jeffries	.....	D26/28

**OTHER PUBLICATIONS**

Toro, Toro Twister, one page, publication date—2002, published in U.S.A.

Polaris, Polaris Ranger 6x6, one page, publication date—2002, published in U.S.A.

Polaris, Polaris Ranger 4x4, one page, publication date—2002, published in U.S.A.

Club Car, Pioneer 1200, one page, publication date—2002, published in U.S.A.

Kawasaki, Kawasaki Mule 3010, one page, publication date—2002, published in U.S.A.

Club Car, Club Car Carryall II, one page, publication date—2002, published in U.S.A.

E-Z Go, E-Z Go Workhorse, one page, publication date—2002, published in U.S.A.

Cub Cadet, Cut Cadet Big Country, one page, publication date—2002, published in U.S.A.

\* cited by examiner

*Primary Examiner*—Marcus A. Jackson

(57) **CLAIM**

The ornamental design for a headlight, as shown and described.

**DESCRIPTION**

FIG. 1 is a right front elevation perspective view of a headlight from the left side showing our new design, with the broken line showing for illustrative purposes only and forming no part of the claimed design;

FIG. 2 is a front right perspective view of the headlight design of FIG. 1.

FIG. 3 is a plan view of the headlight design of FIG. 1.

FIG. 4 is a right side view of the headlight design of FIG. 1.

FIG. 5 is a front view of the headlight design of FIG. 1.

FIG. 6 is a left front elevation perspective view of a headlight from the right side thereof;

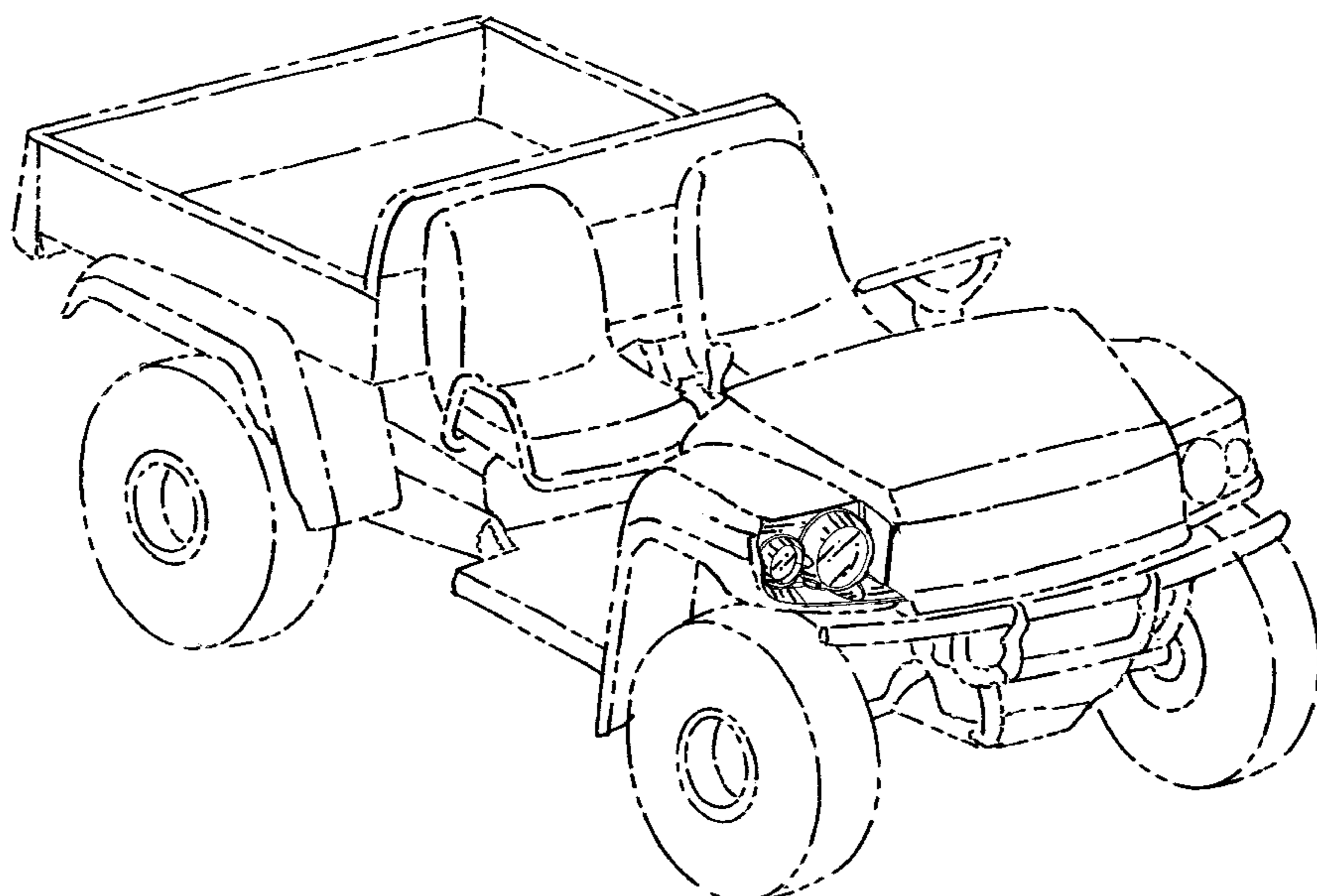
FIG. 7 is a front left perspective view of the headlight design of FIG. 6.

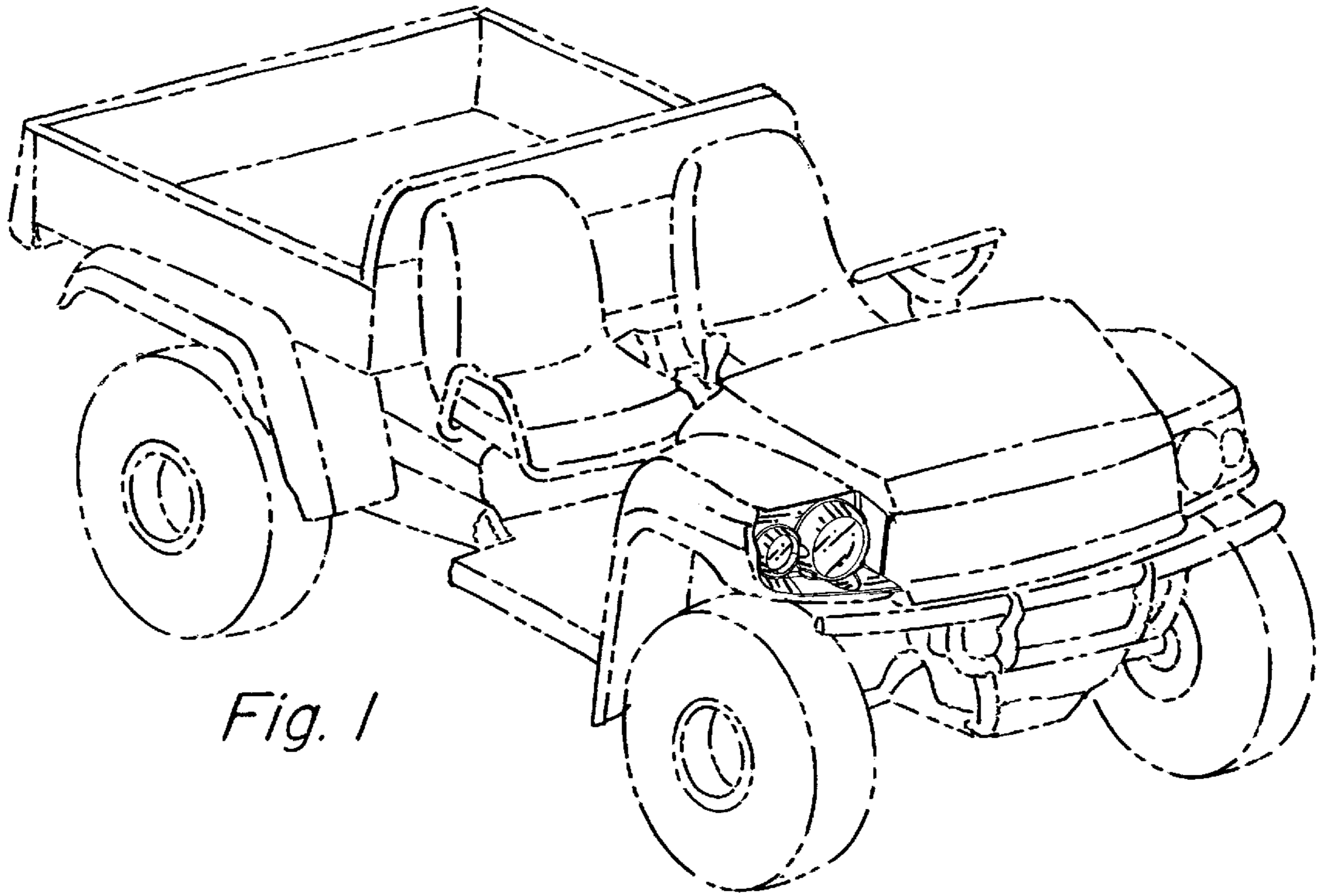
FIG. 8 is a plan view of the headlight design of FIG. 6.

FIG. 9 is a left side view of the headlight design of FIG. 6; and,

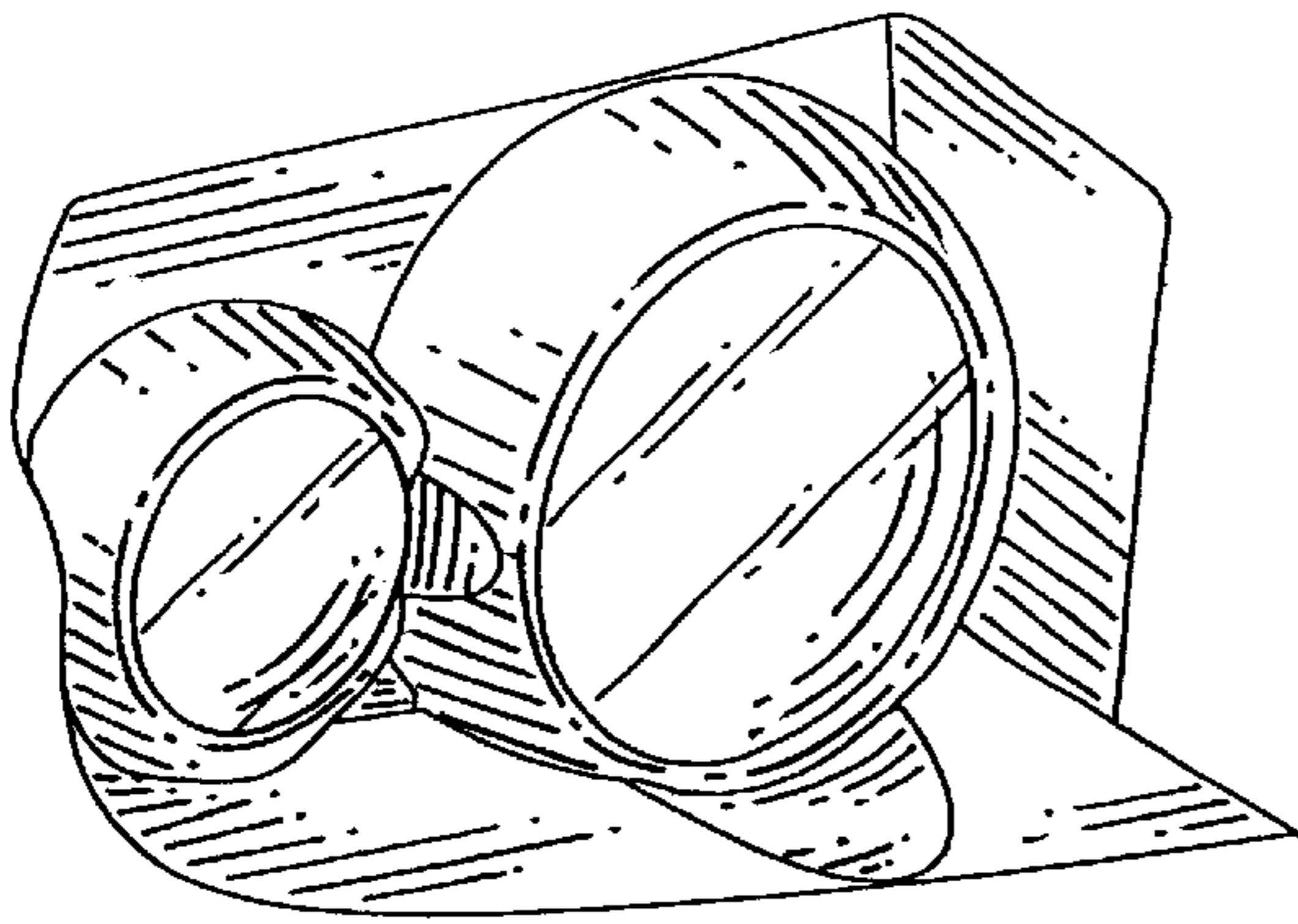
FIG. 10 is a front view of the headlight design of FIG. 6.

**1 Claim, 2 Drawing Sheets**

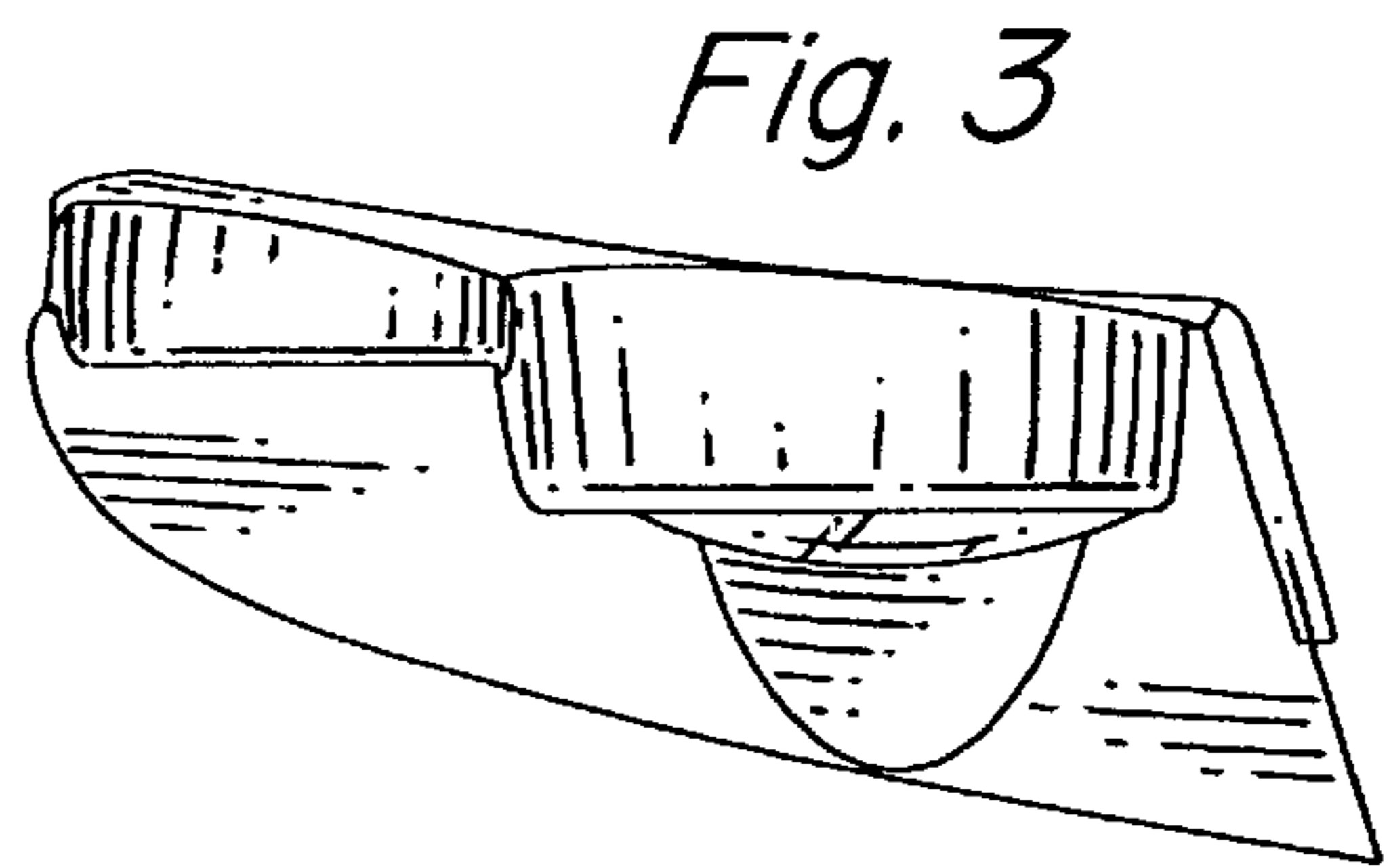




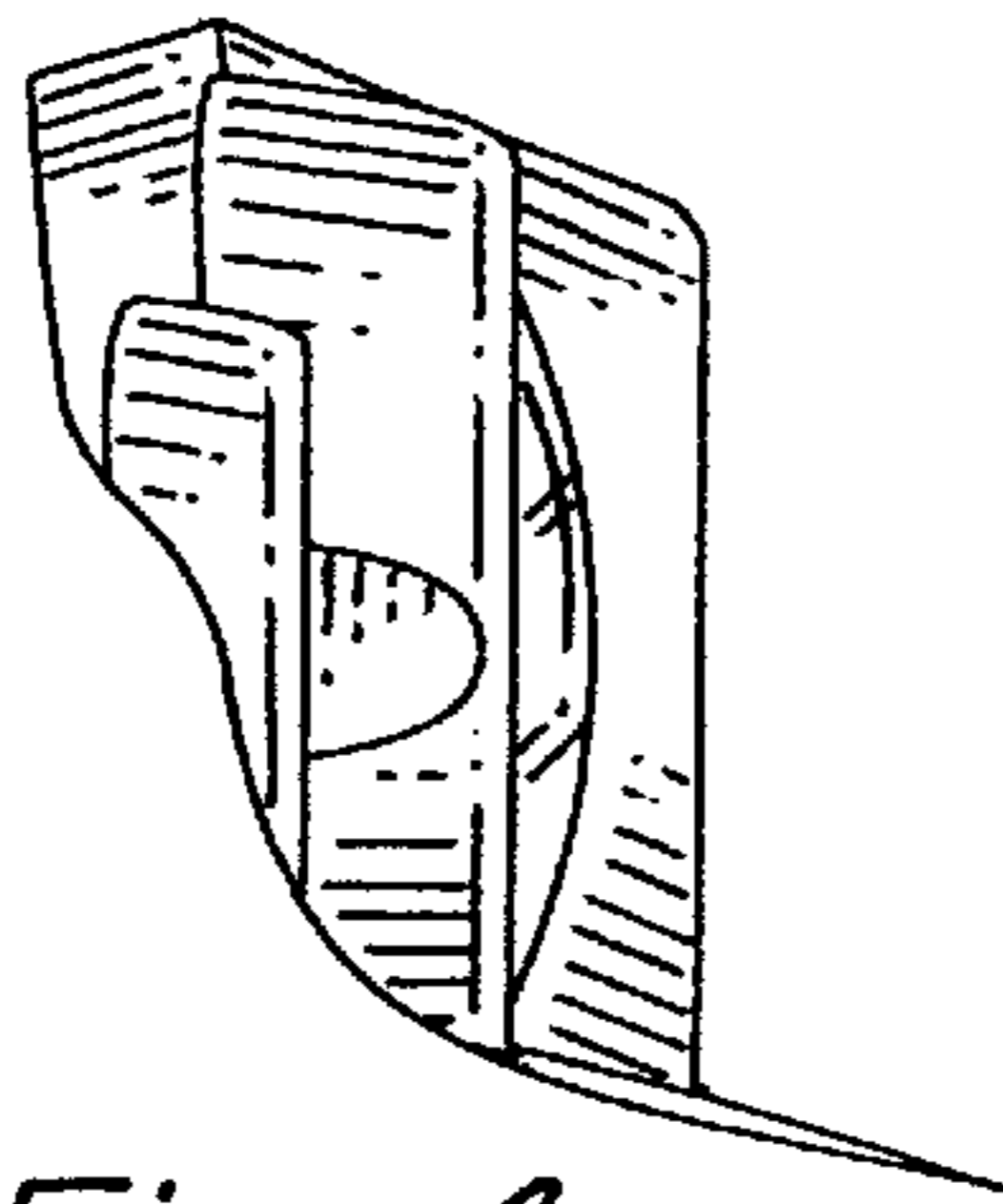
*Fig. 1*



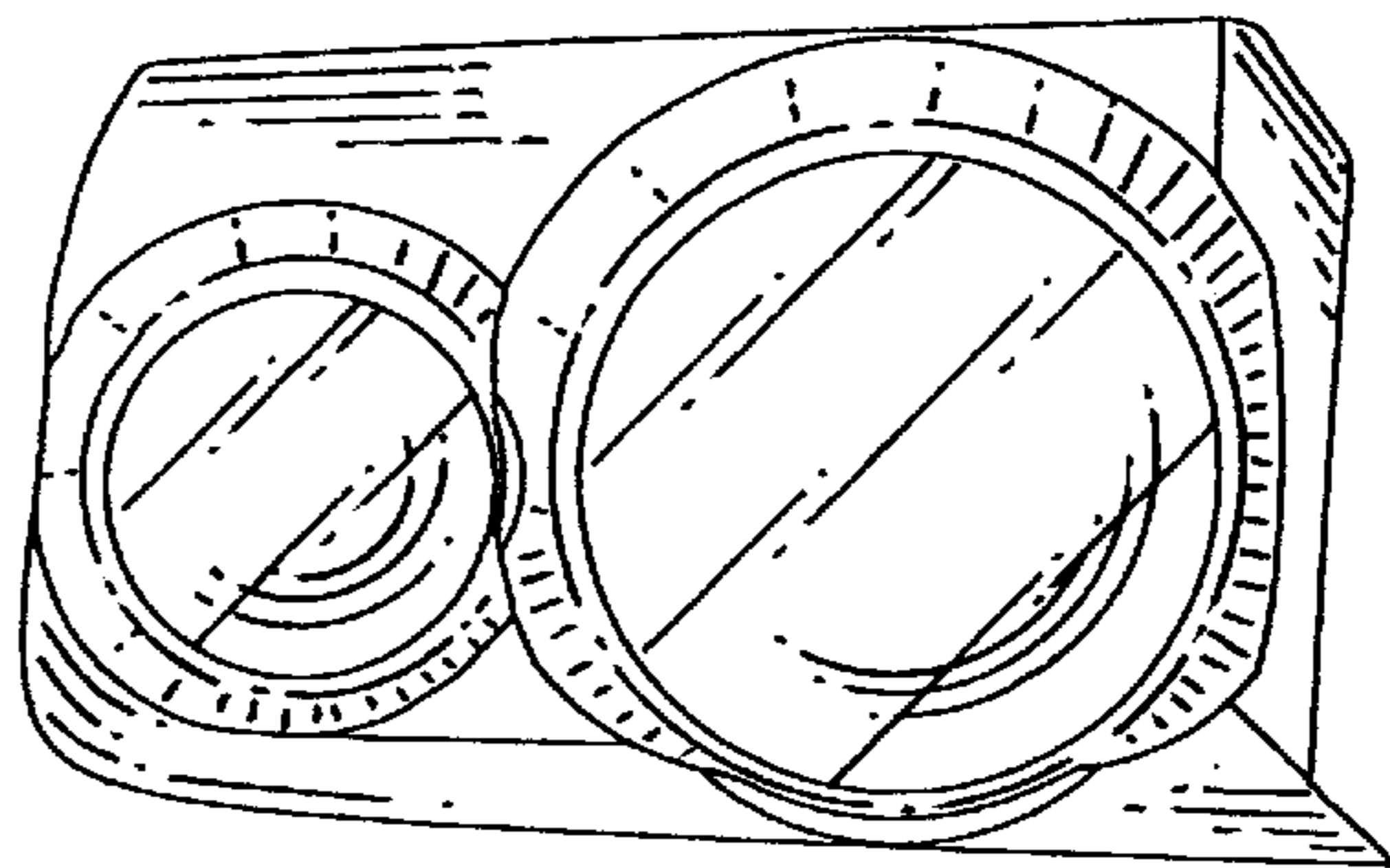
*Fig. 2*



*Fig. 3*

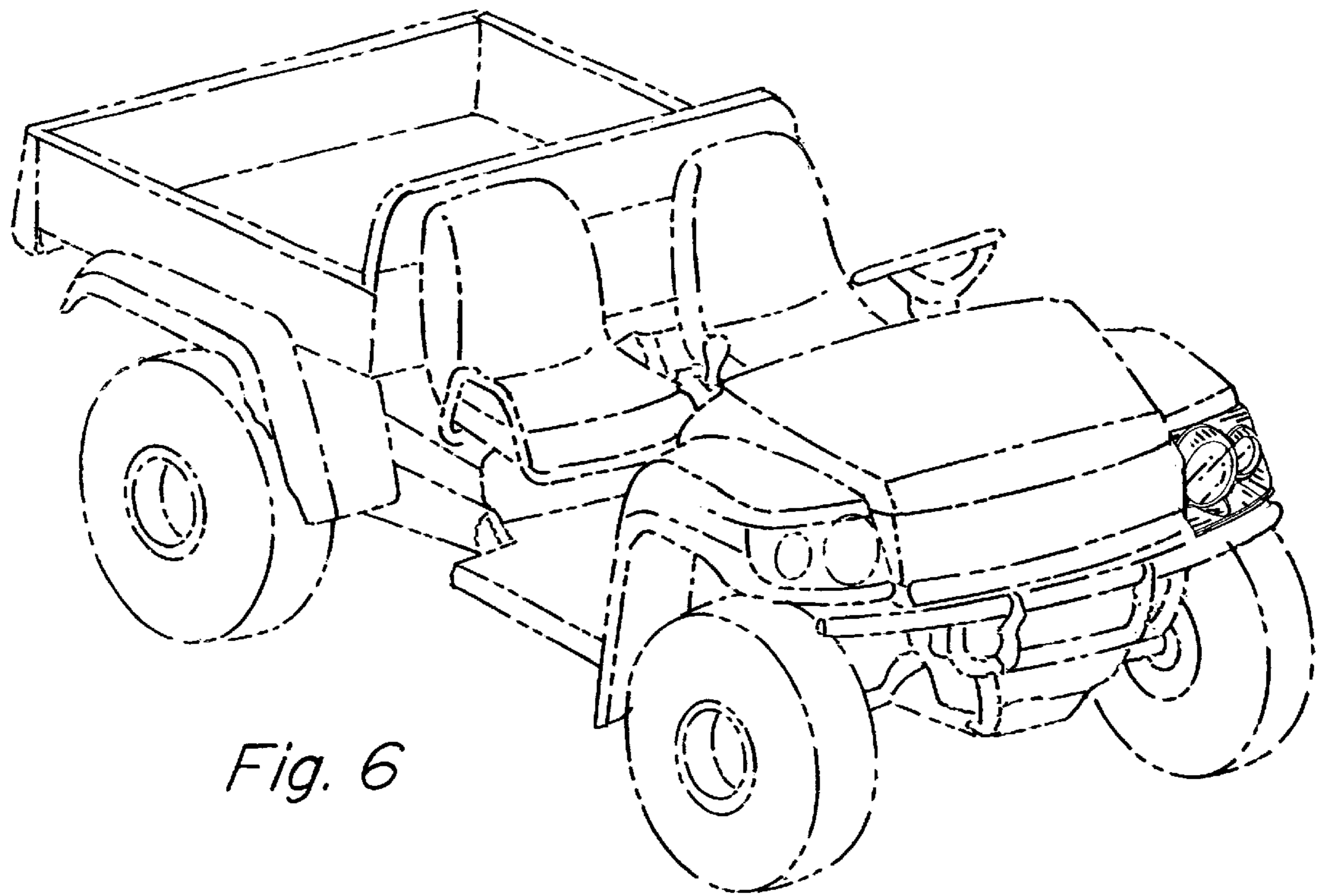


*Fig. 4*

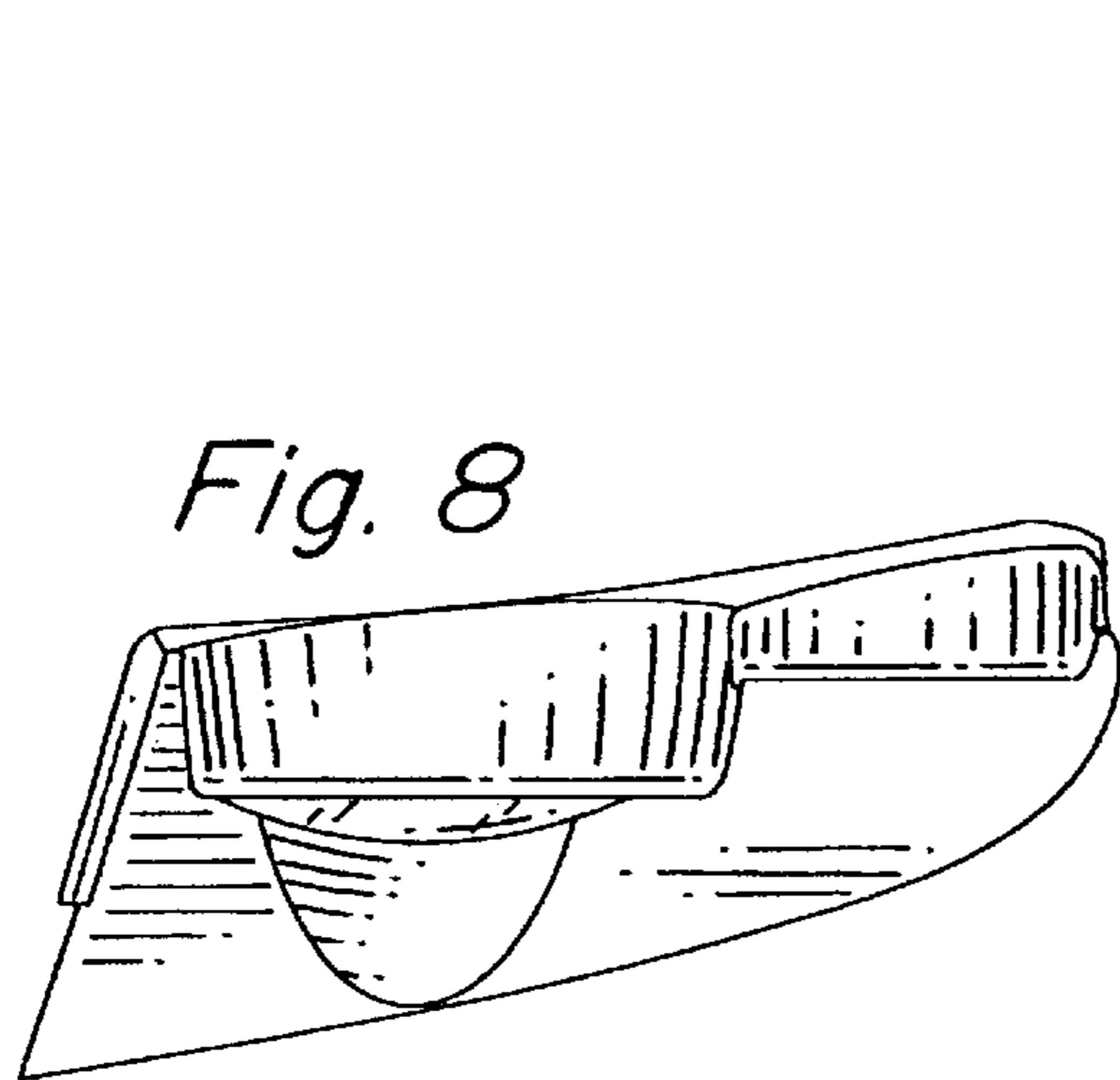


*Fig. 5*

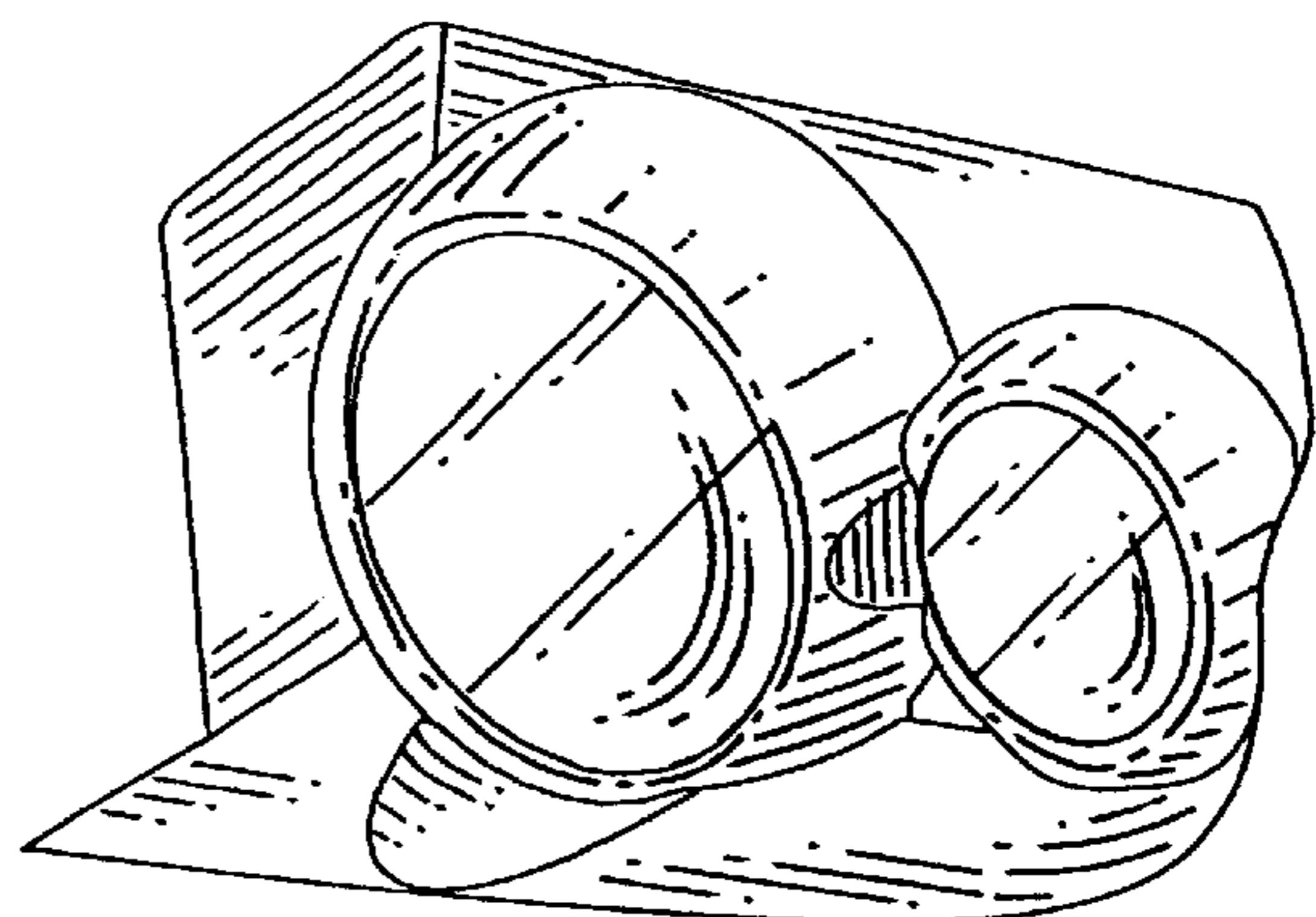




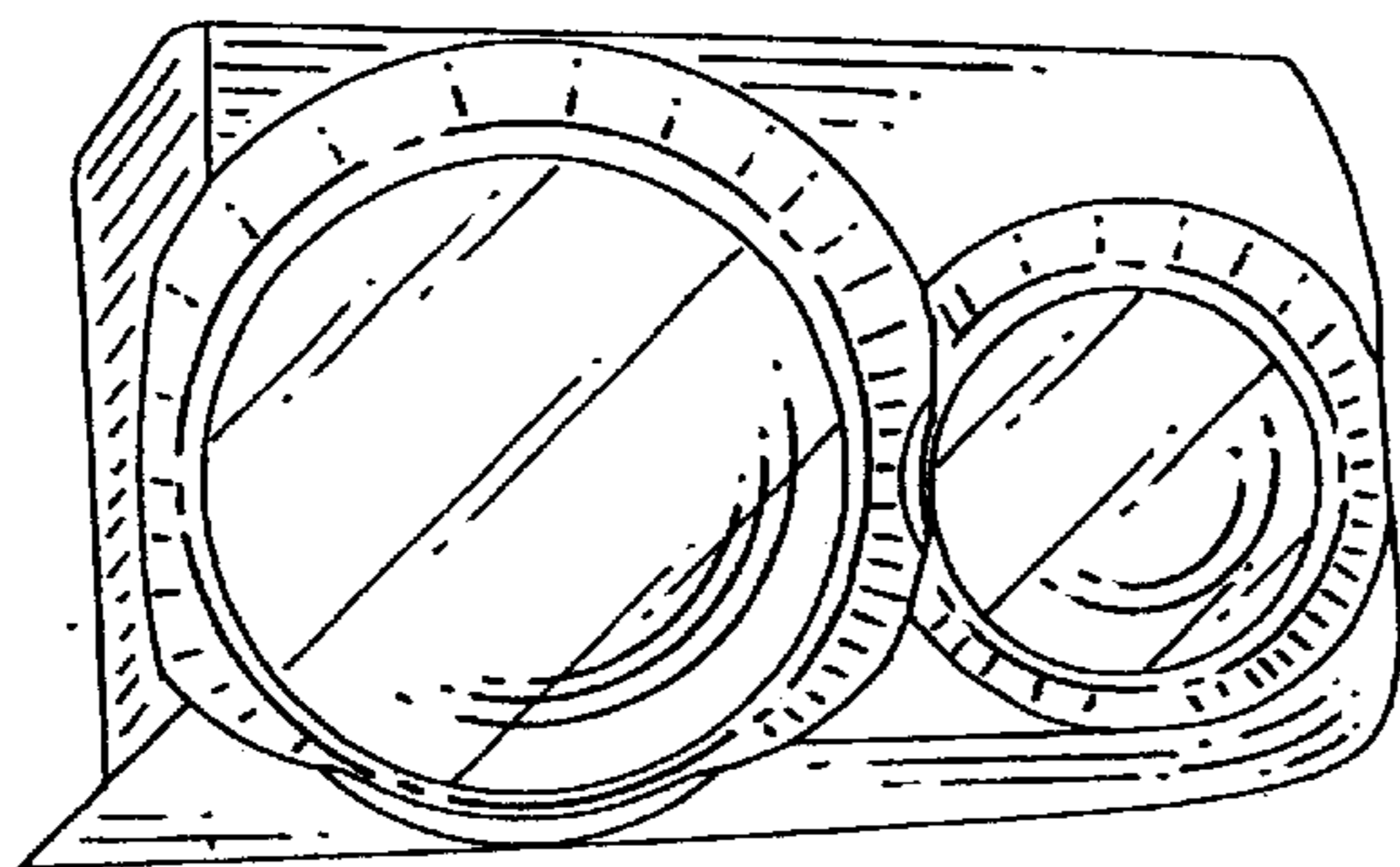
*Fig. 6*



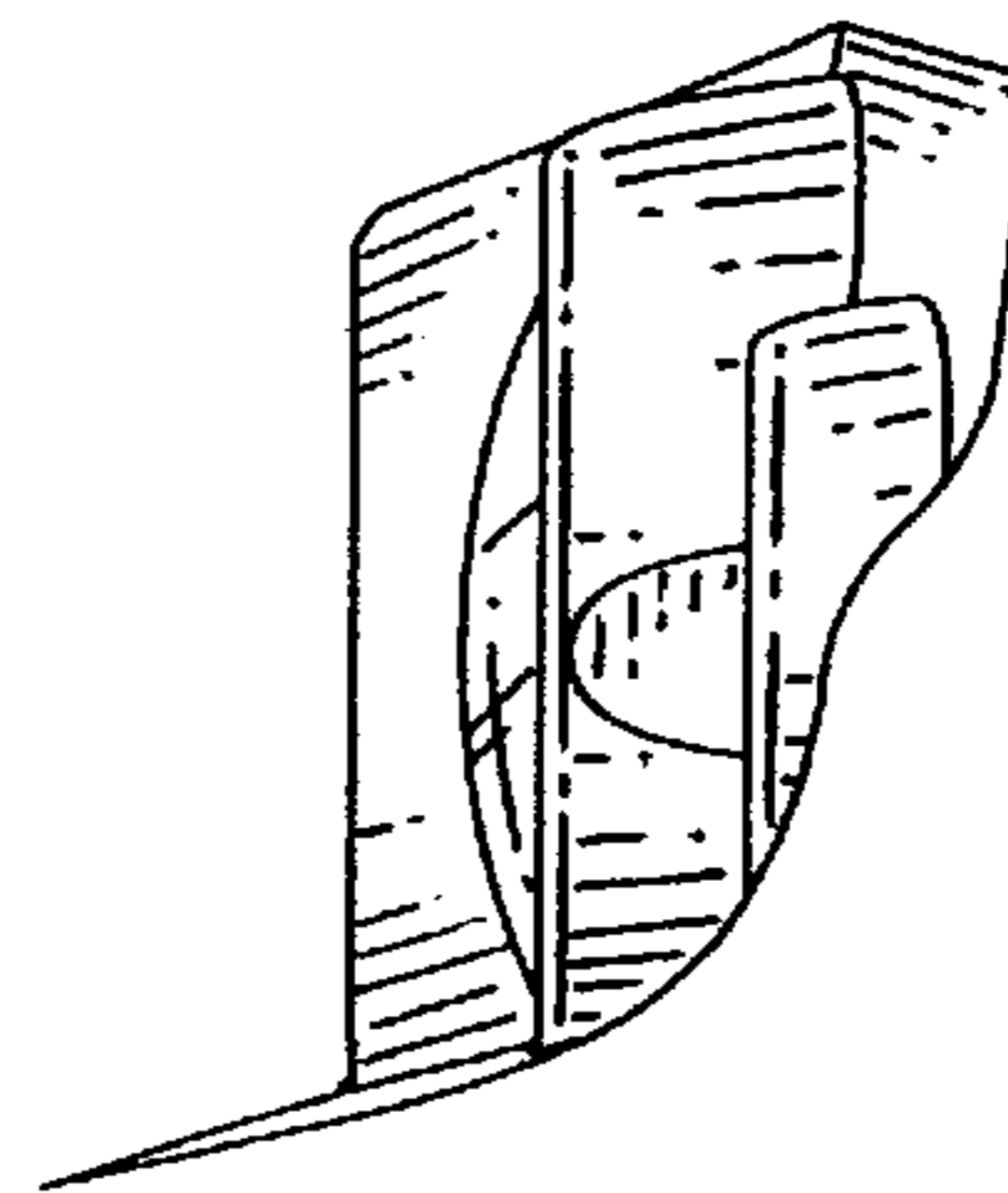
*Fig. 8*



*Fig. 7*



*Fig. 10*



*Fig. 9*