



US00D477209S

(12) **United States Design Patent**
Yu et al.

(10) **Patent No.:** **US D477,209 S**

(45) **Date of Patent:** **** *Jul. 15, 2003**

(54) **LOCK BODY**

(76) Inventors: **Chun Te Yu**, 41-21, Guan Tso Street, Fu Shing, Changhwa (TW), 506; **Ming Chang Shih**, No. 3, Lane 438, Minsheng Rd., Changhwa City (TW), 500

(*) Notice: This patent is subject to a terminal disclaimer.

(**) Term: **14 Years**

(21) Appl. No.: **29/149,717**

(22) Filed: **Oct. 17, 2001**

(51) **LOC (7) Cl.** **08-07**

(52) **U.S. Cl.** **D8/334**

(58) **Field of Search** D8/330, 331, 334; 70/20, 21, 22, 24-29, 30, 50, 52

Primary Examiner—Brian N. Vinson
(74) Attorney, Agent, or Firm—Rosenberg, Klein & Lee

(57) **CLAIM**

The ornamental design for a lock body, as shown and described.

DESCRIPTION

FIG. 1 is a front-right-top perspective view of a lock body, showing my new design;
FIG. 2 is a front elevational view thereof;
FIG. 3 is a rear elevational view thereof;
FIG. 4 is a left side elevational view thereof;
FIG. 5 is a right side elevational view thereof;
FIG. 6 is a top plan view thereof;
FIG. 7 is a bottom plan view thereof;
FIG. 8 is a perspective view showing an embodiment of the claimed design, wherein the broken lines are shown for illustrative purposes only and form no part of the claimed design; and,
FIG. 9 is a perspective view showing an embodiment of the claimed design, wherein the broken lines are shown for illustrative purposes only and form no part of the claimed design.

1 Claim, 6 Drawing Sheets

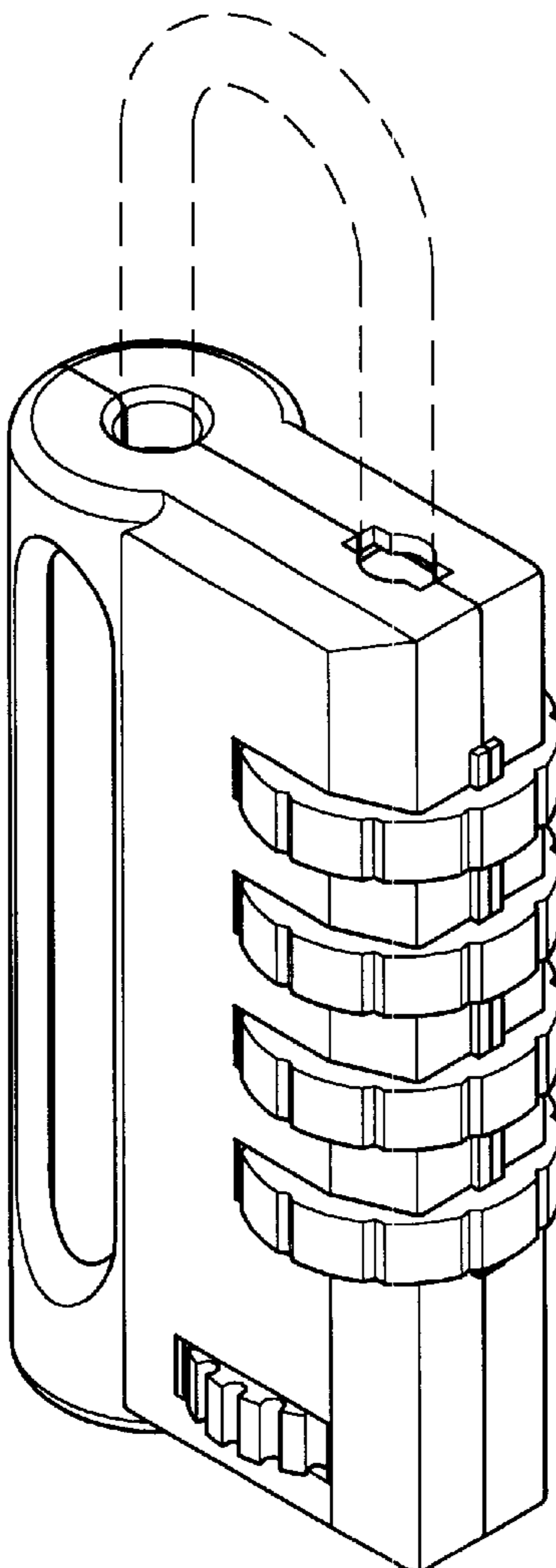

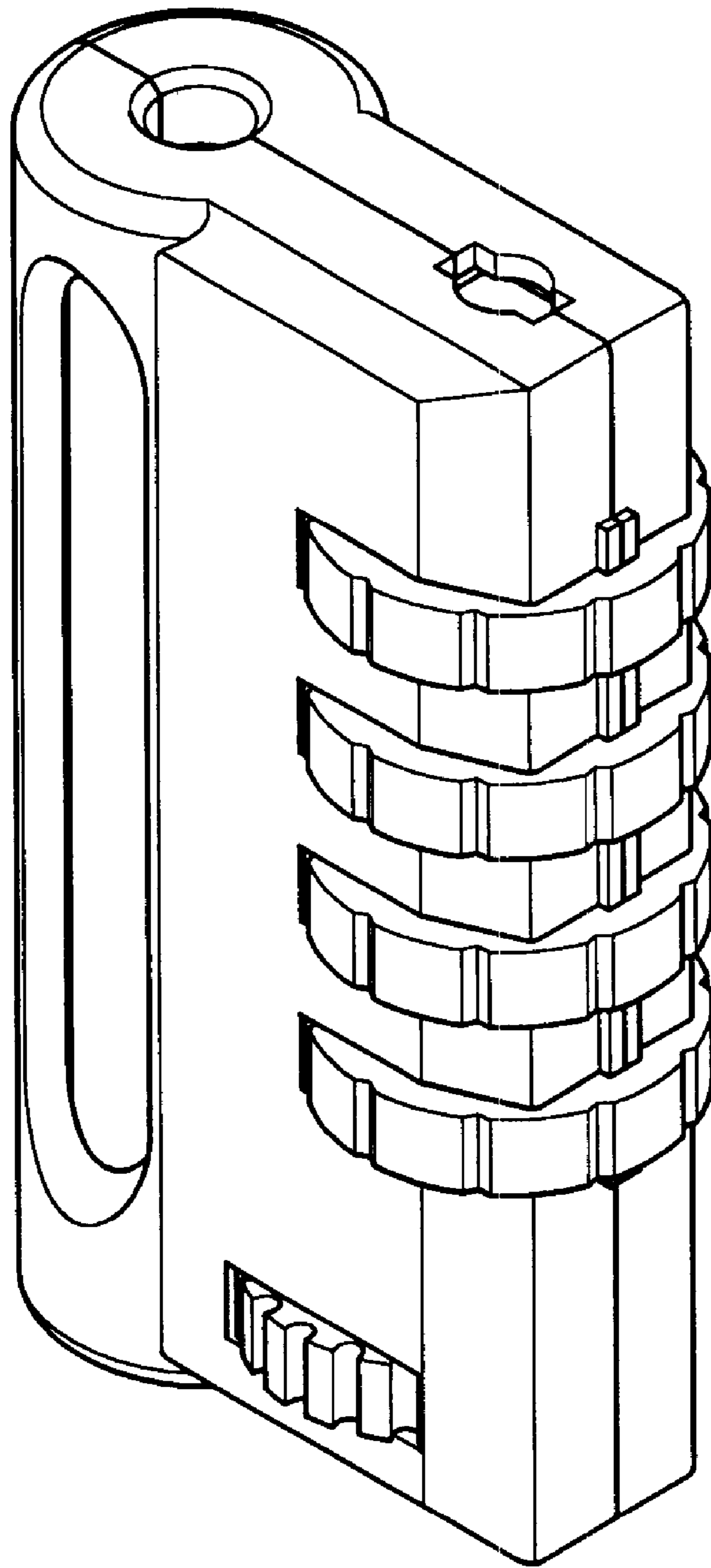

FIG. 1

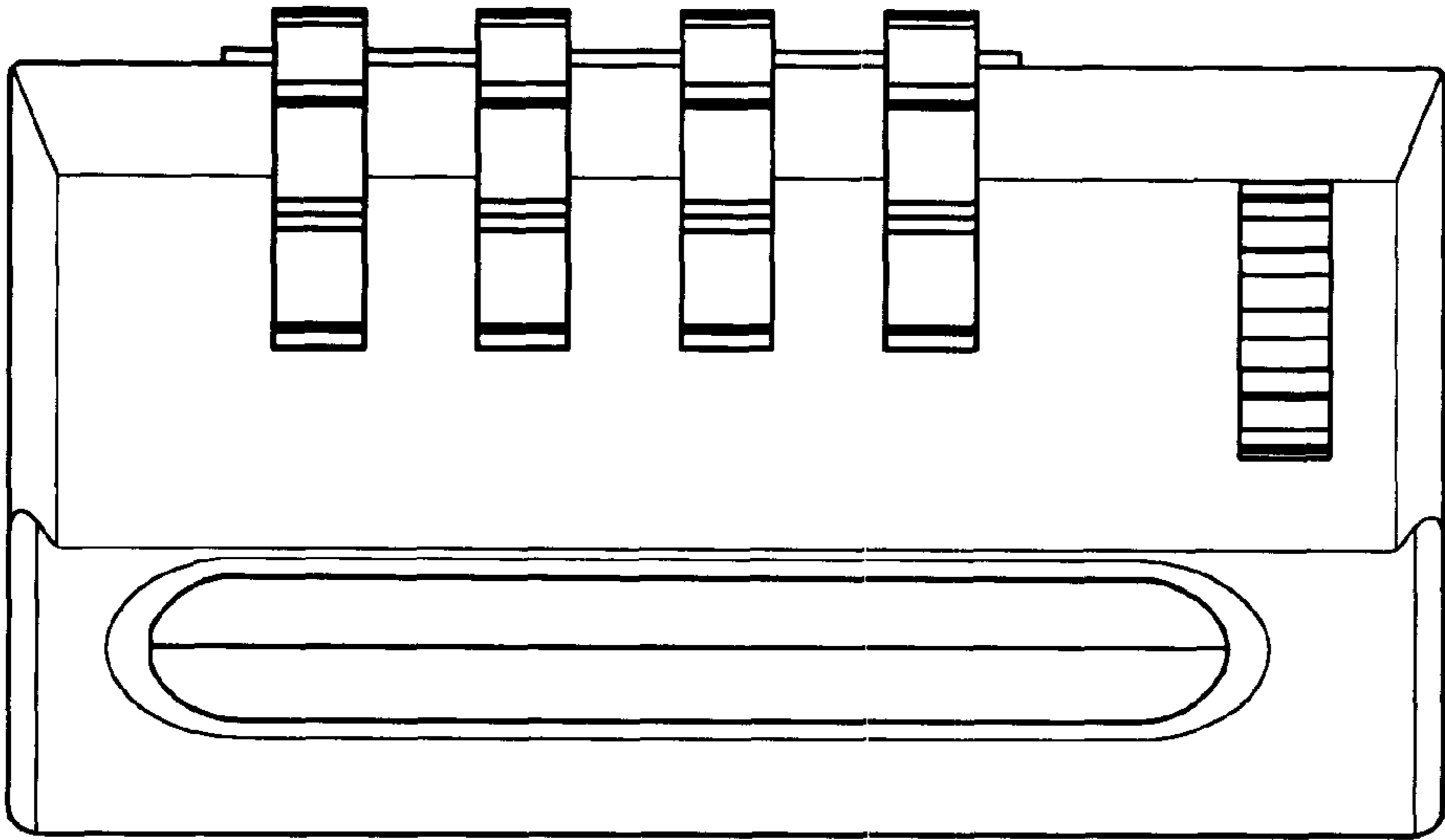

FIG. 2

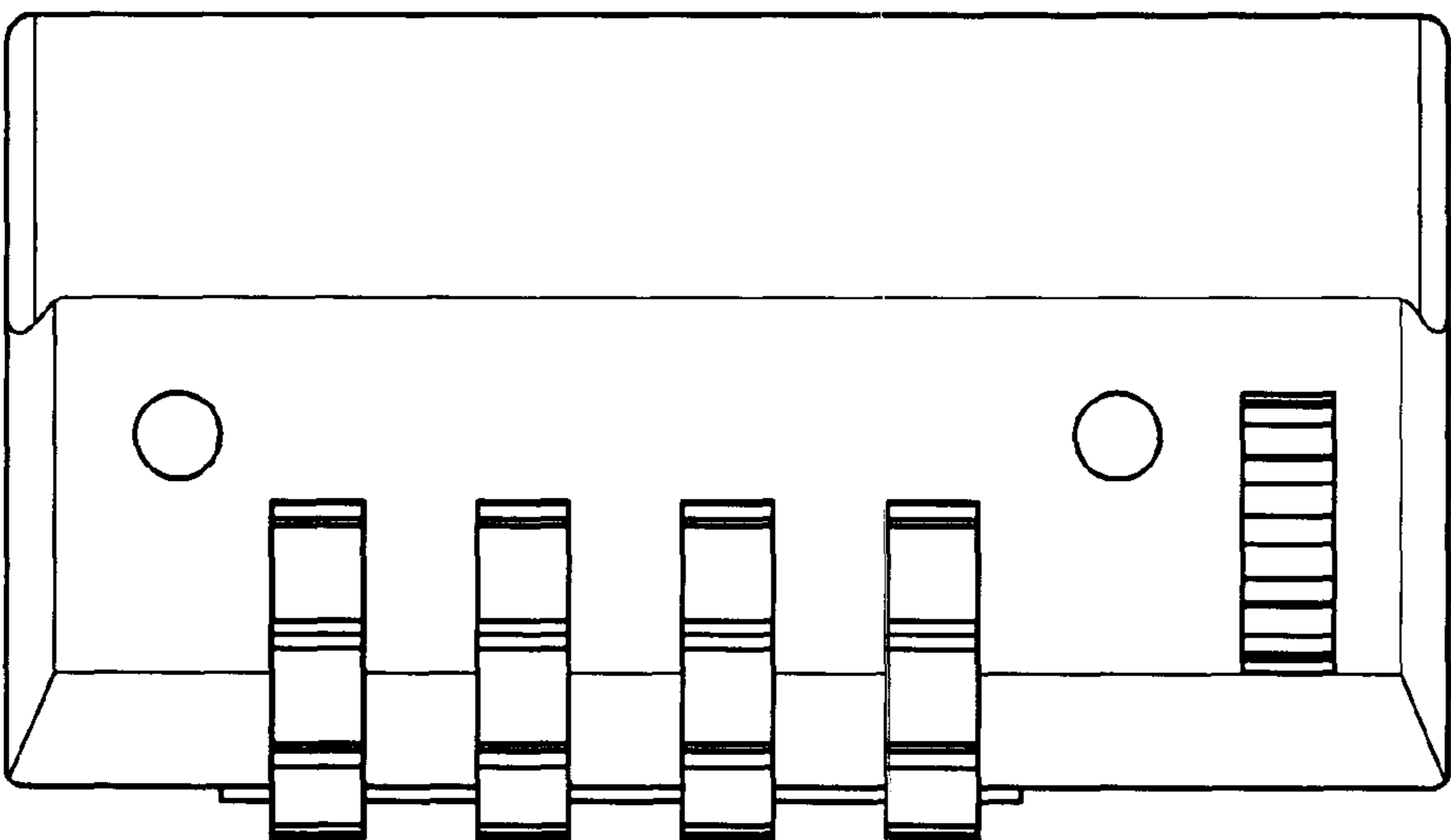

FIG. 3

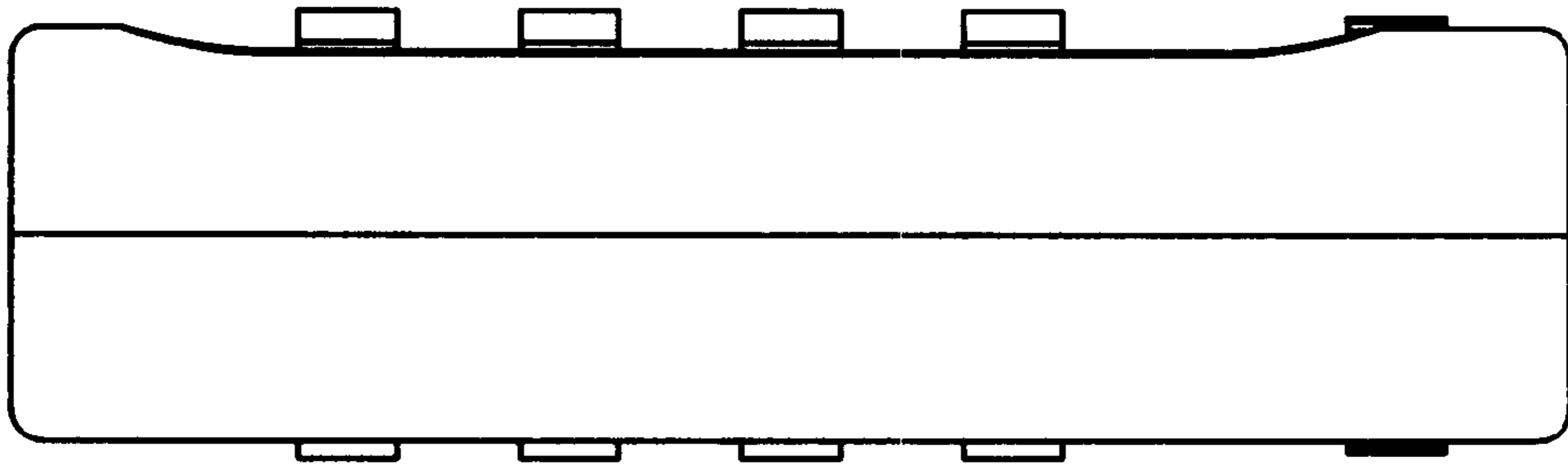

FIG. 4

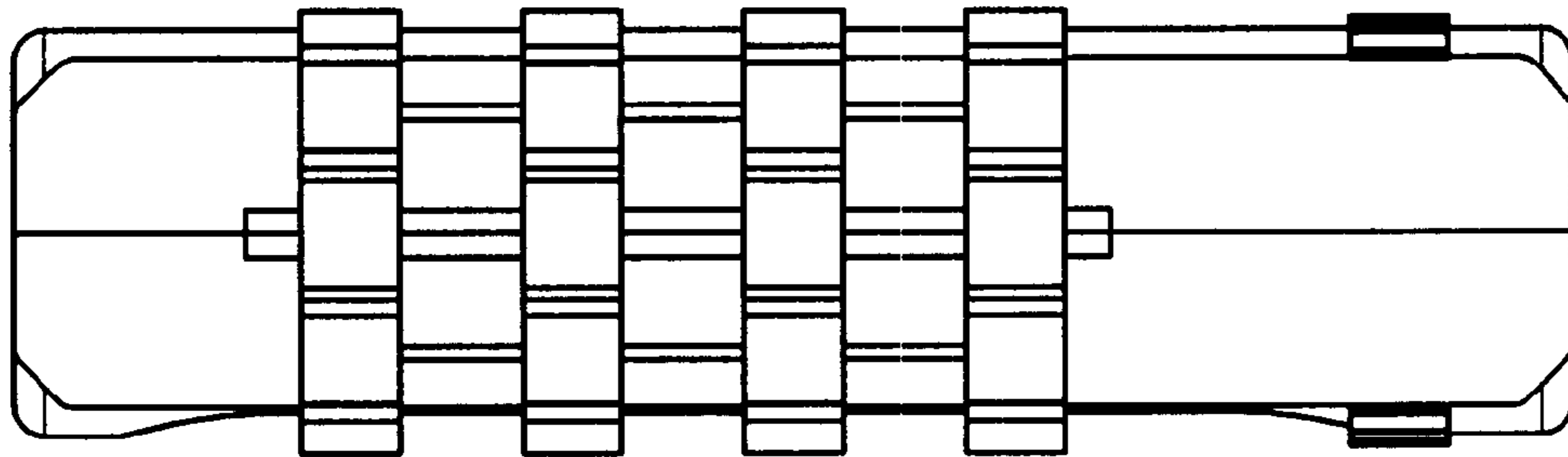

FIG. 5

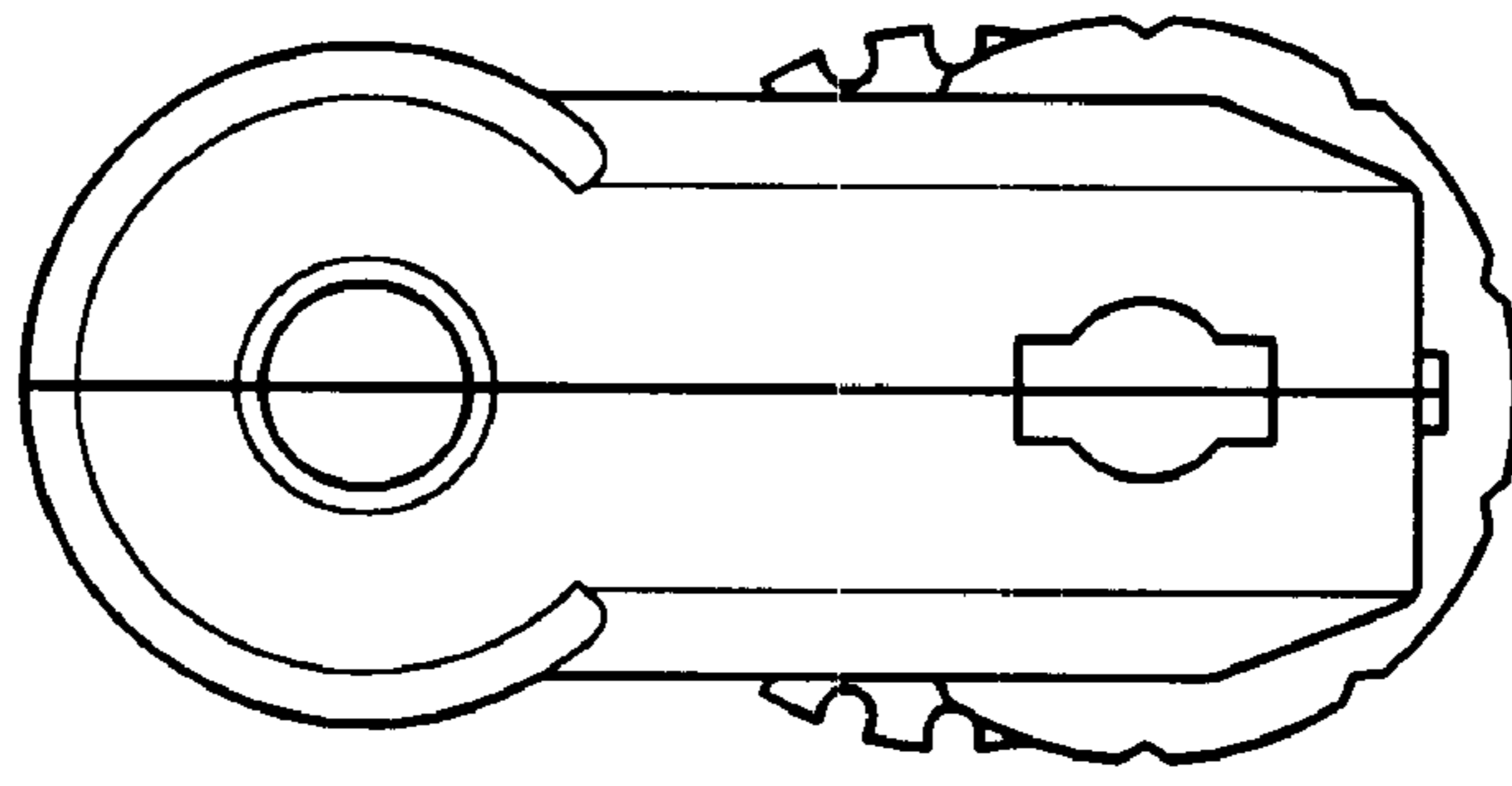

FIG. 6

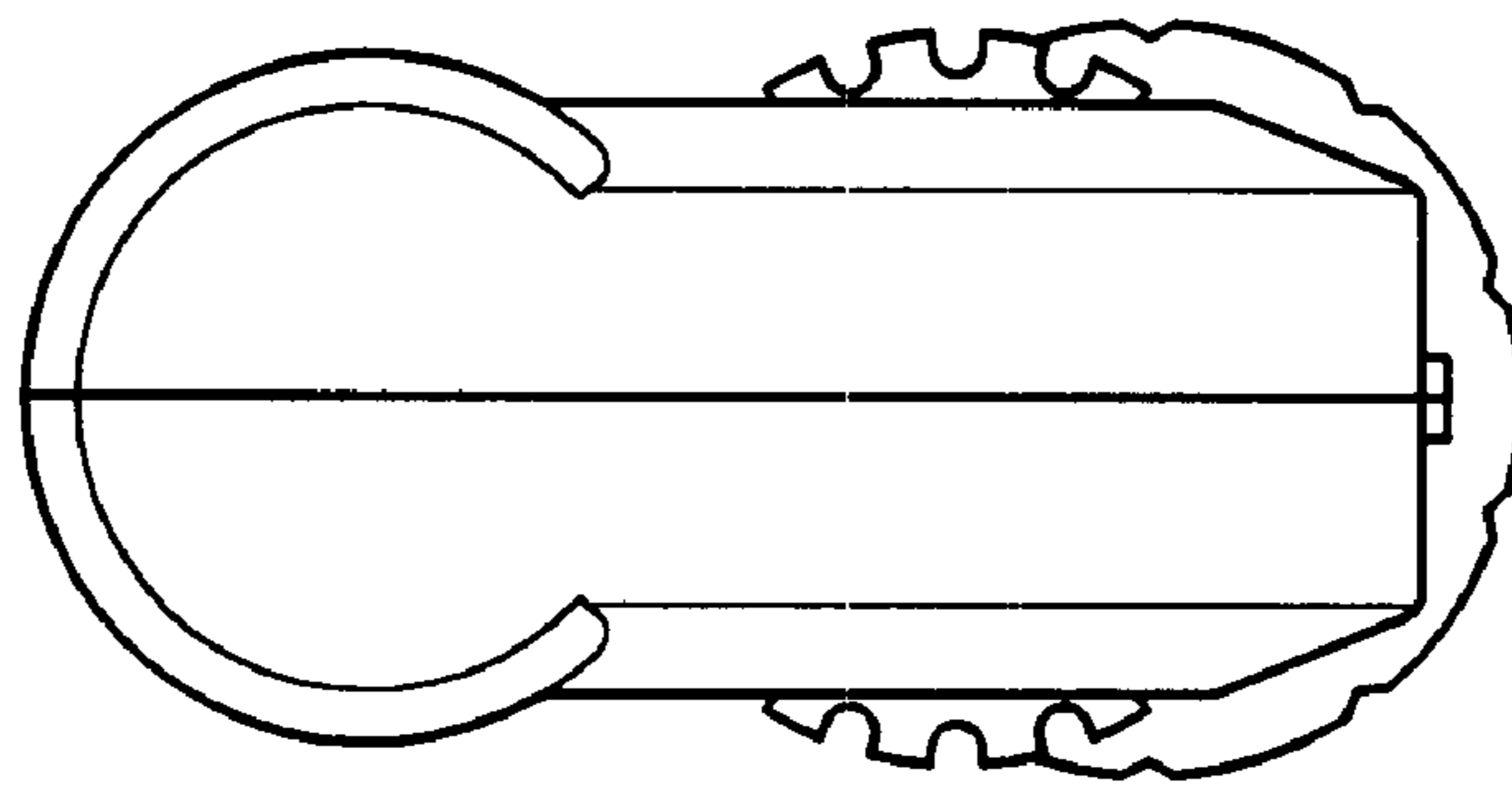

FIG. 7

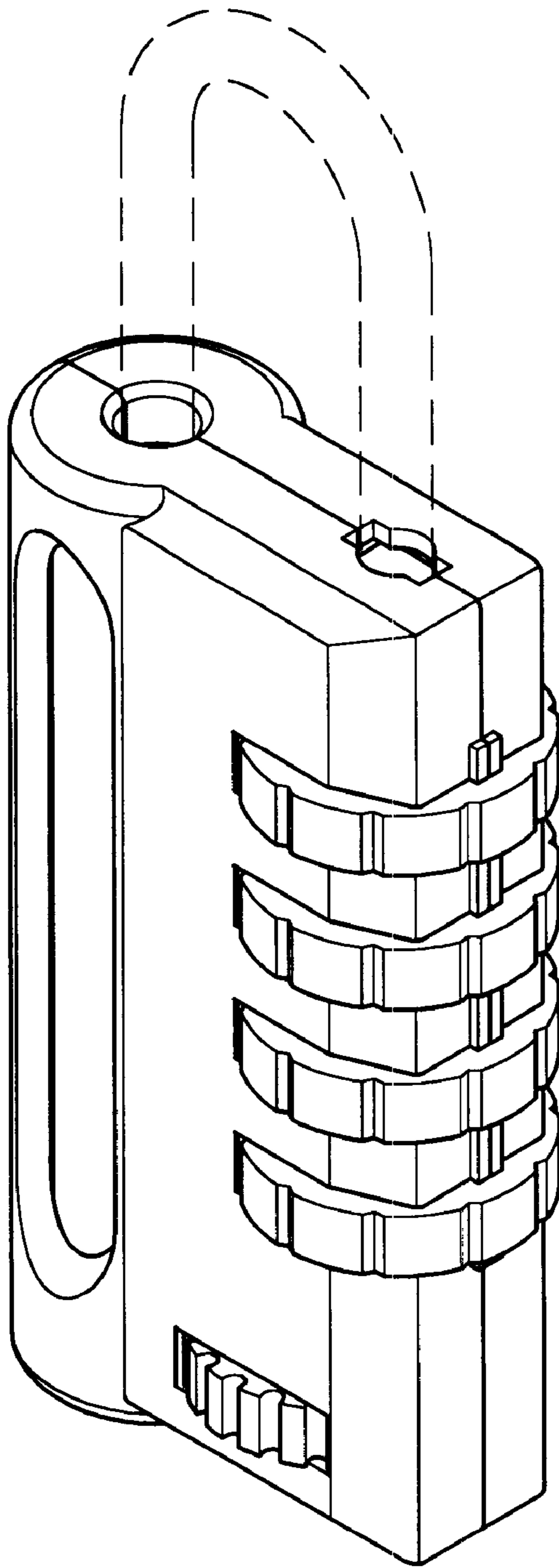

FIG. 8

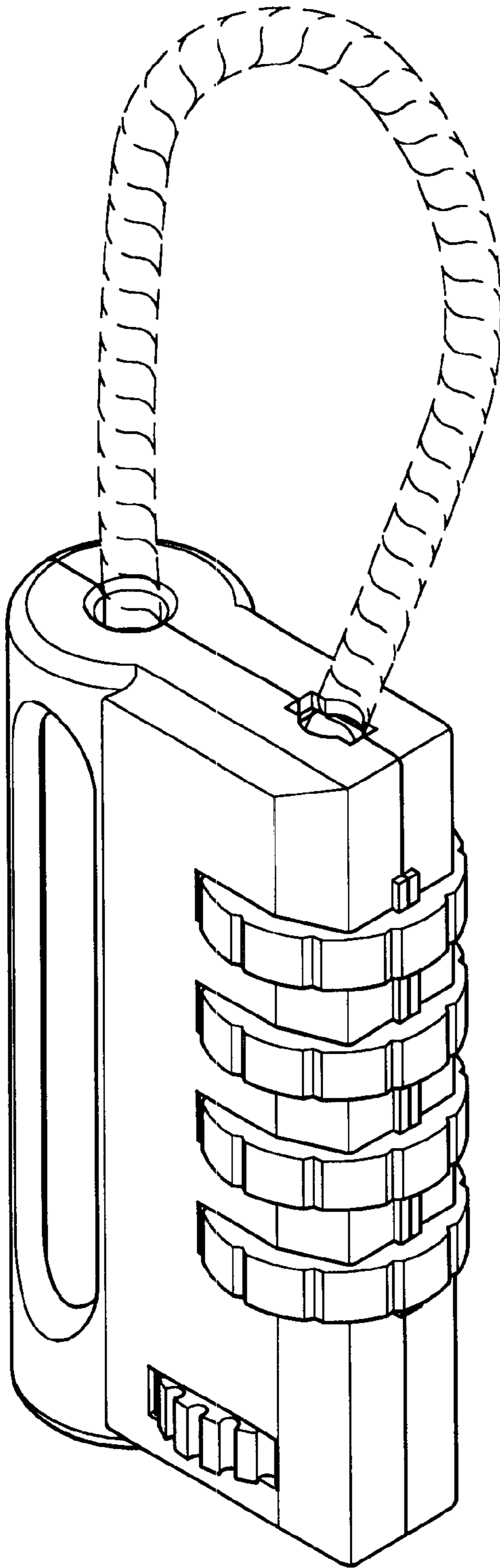

FIG. 9