



US00D476763S

(12) **United States Design Patent**
Horowitz

(10) **Patent No.:** **US D476,763 S**

(45) **Date of Patent:** **** Jul. 1, 2003**

(54) **TAILLIGHT ASSEMBLY**

(75) Inventor: **Brian A. Horowitz**, Mission Viejo, CA (US)

(73) Assignee: **American Products Company**, Corona, CA (US)

(**) Term: **14 Years**

(21) Appl. No.: **29/175,720**

(22) Filed: **Feb. 7, 2003**

(51) **LOC (7) Cl.** **26-04**

(52) **U.S. Cl.** **D26/28**

(58) **Field of Search** D26/28-36, 120,
D26/122; 362/61, 80, 81, 82, 83, 83.4,
267, 269, 275

(56) **References Cited**

U.S. PATENT DOCUMENTS

D448,869 S	10/2001	Horowitz	
D459,505 S	6/2002	Horowitz	
D460,574 S	7/2002	Horowitz	
D468,462 S	* 1/2003	Horowitz D26/28
D469,898 S	* 2/2003	Pan et al. D26/28
D471,660	* 3/2003	Horowitz et al. D26/28
D472,002	* 3/2003	Chen et al. D26/28

OTHER PUBLICATIONS

Photograph (three quarter view) of stock taillight on 2002 Chevrolet S-10.

American Products Company 2001 Catalog (published Oct. 10, 2002), p. 13, part # 404112TLR & 404112TLCF.

American Products Company 2002 Catalog (published Jan. 3, 2002), pp. 9-10, part # 404512TLRS & 404512TLR.

American Products Company 2002 Catalog p. 12 (published Feb. 21, 2002), part #3414112CFR.

Advertisement, Stilen Sports Cars from Sport Compact Car, vol. 13, No. 3, Mar. 2001, pp. 58-59.

Elegante by TYC Version 2.02 Catalog (Copyright 2002), p. 08.

Macro Automotive Products Brochure (available Nov. 2001), Chevy S-10.

Matrix GR Motorsports 2002 Catalog (available Nov. 2001), p. 17, part # 09-802.

Hiper Industries 2002 Catalog (available Nov. 2001), p. 4, part #CS1094* (94-up Chevy S-10).

Z2000 Brochure (available Nov. 2001), S-10 Pickup 94-.

* cited by examiner

Primary Examiner—Marcus A. Jackson

(74) *Attorney, Agent, or Firm*—Knobbe Martens Olson & Bear, LLP

(57) **CLAIM**

The ornamental design for an taillight assembly, as shown and described.

DESCRIPTION

FIG. 1 is a front-right side three-quarter view of the taillight assembly according to the present design;

FIG. 2 is a front elevational view of the taillight assembly of FIG. 1;

FIG. 3 is a right side elevational view of the taillight assembly of FIG. 1;

FIG. 4 is a top elevational view of the taillight assembly of FIG. 1; and,

FIG. 5 is a front-right side three-quarter view of the taillight assembly of FIG. 1, shown with the taillight assembly installed on a vehicle.

Phantom lining, where used, is for illustrative purposes only and is not intended to limit the claimed design to the features shown in phantom.

1 Claim, 3 Drawing Sheets

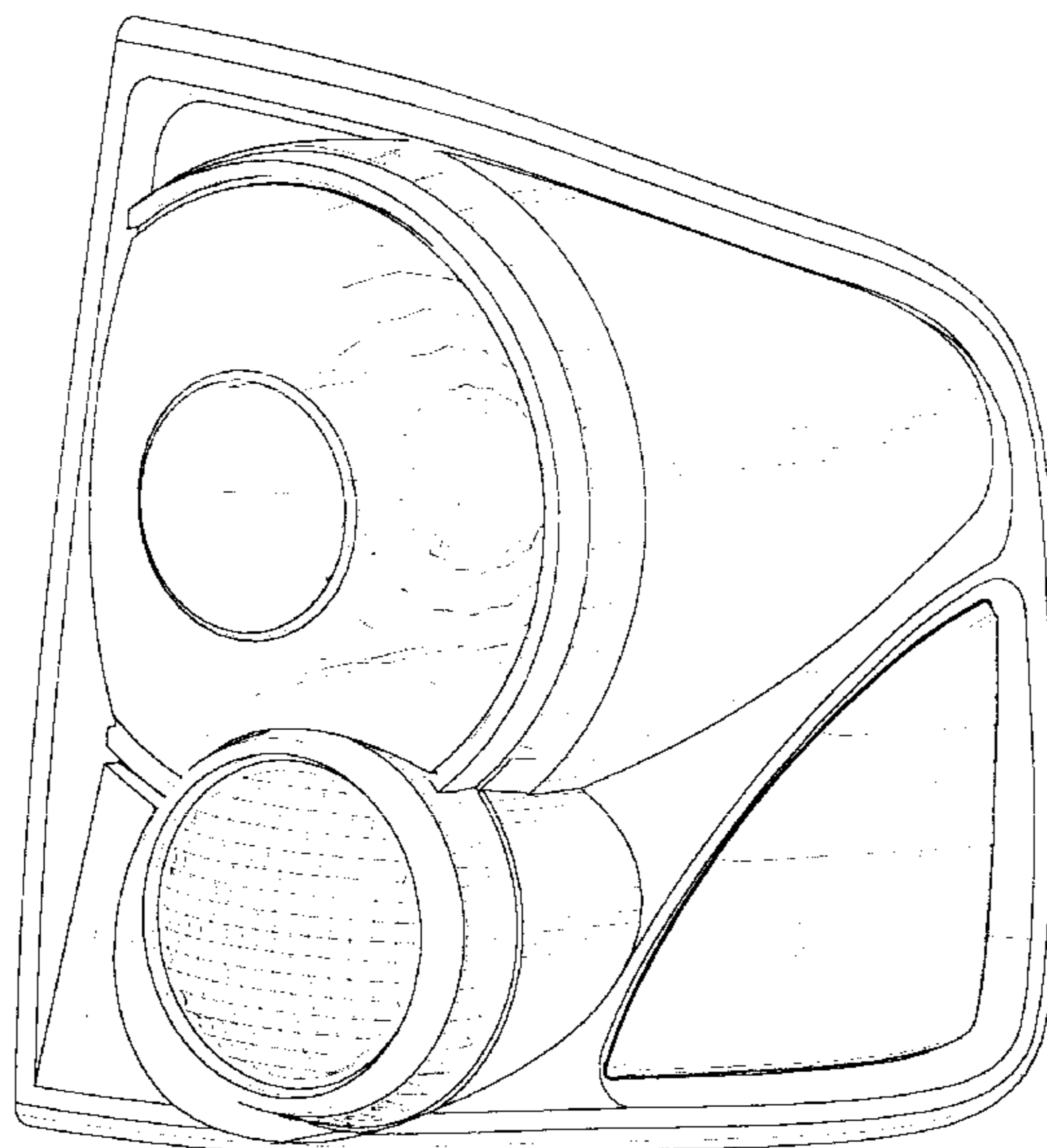

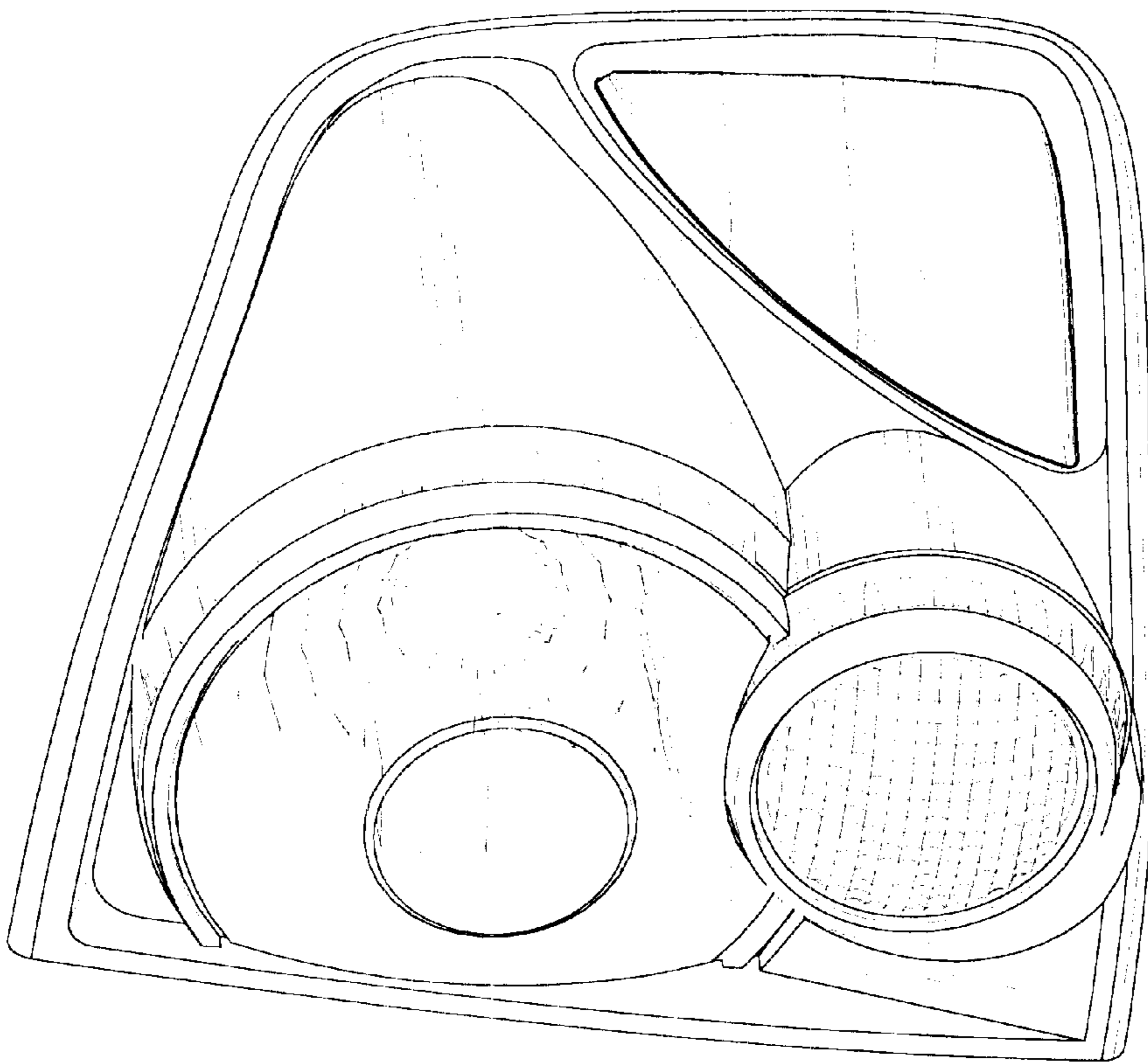

FIG. 1

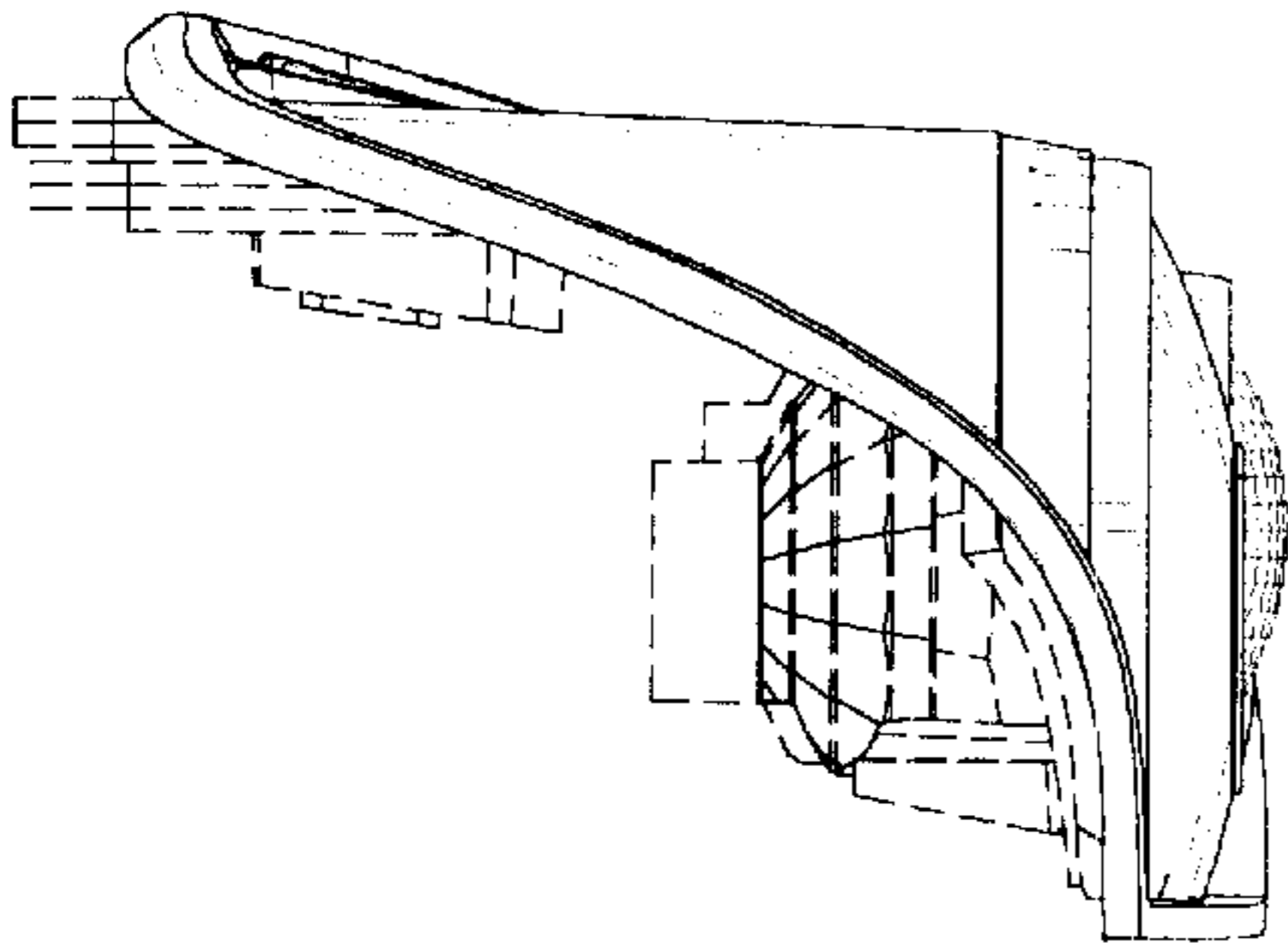

FIG. 4

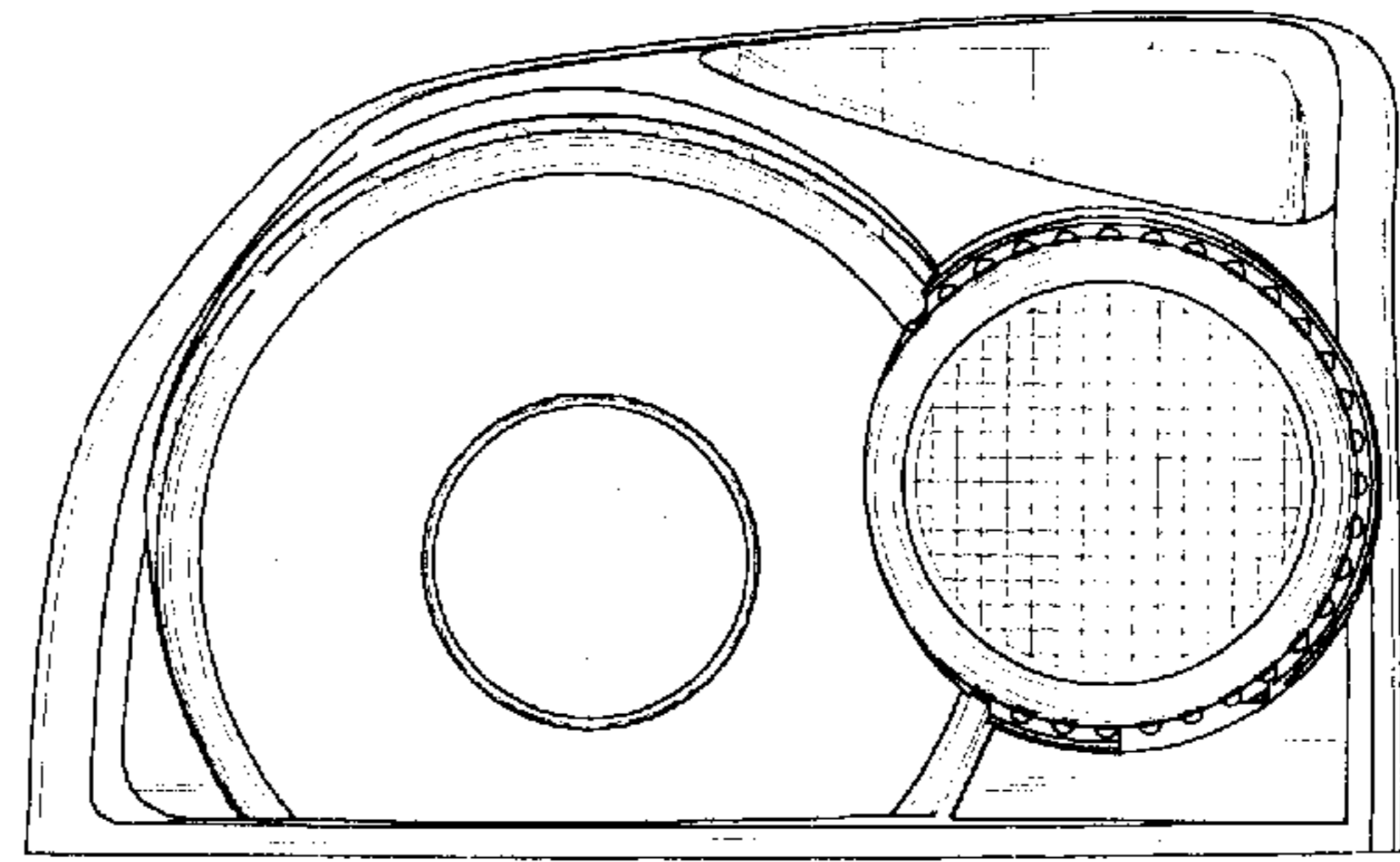

FIG. 2

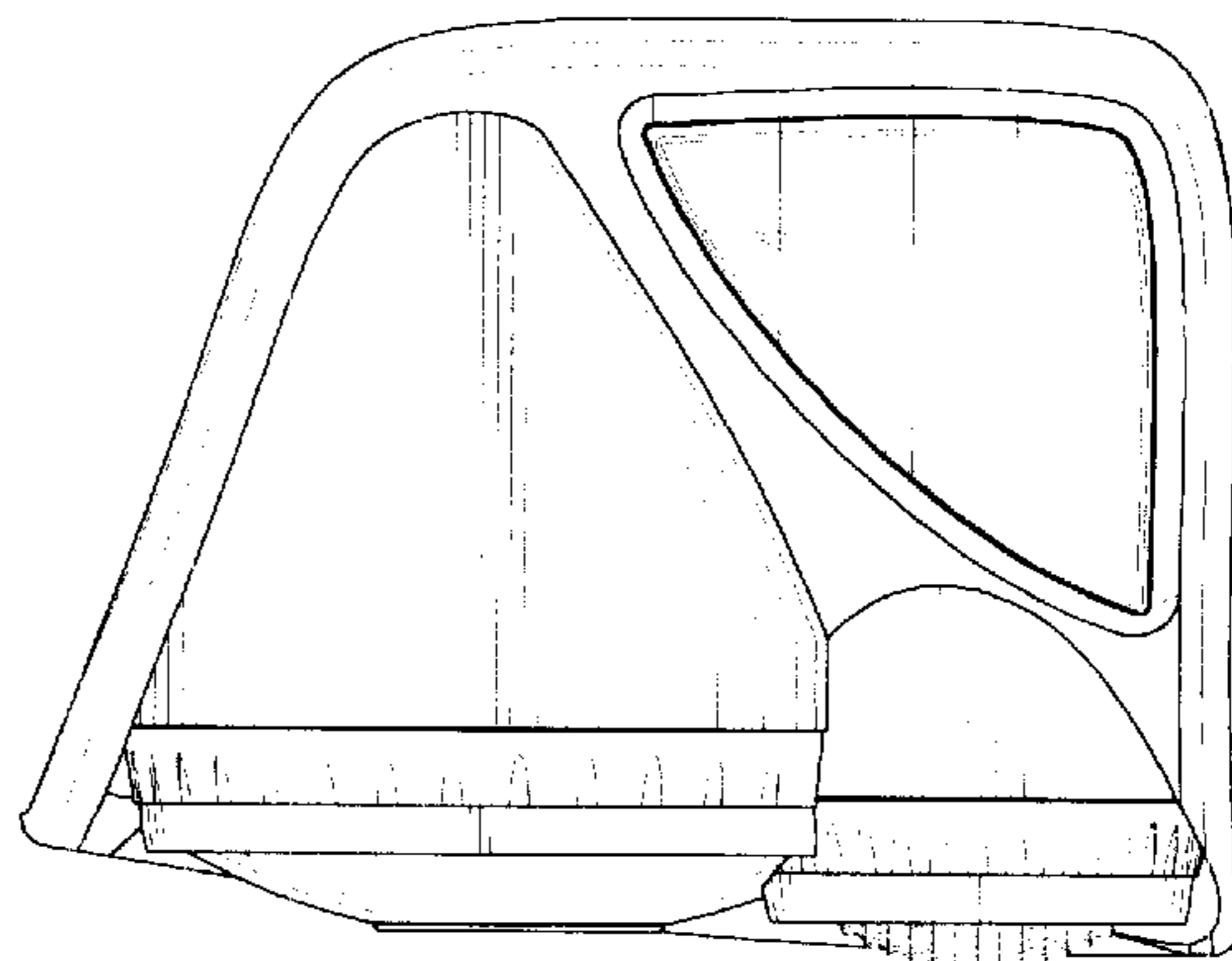

FIG. 3

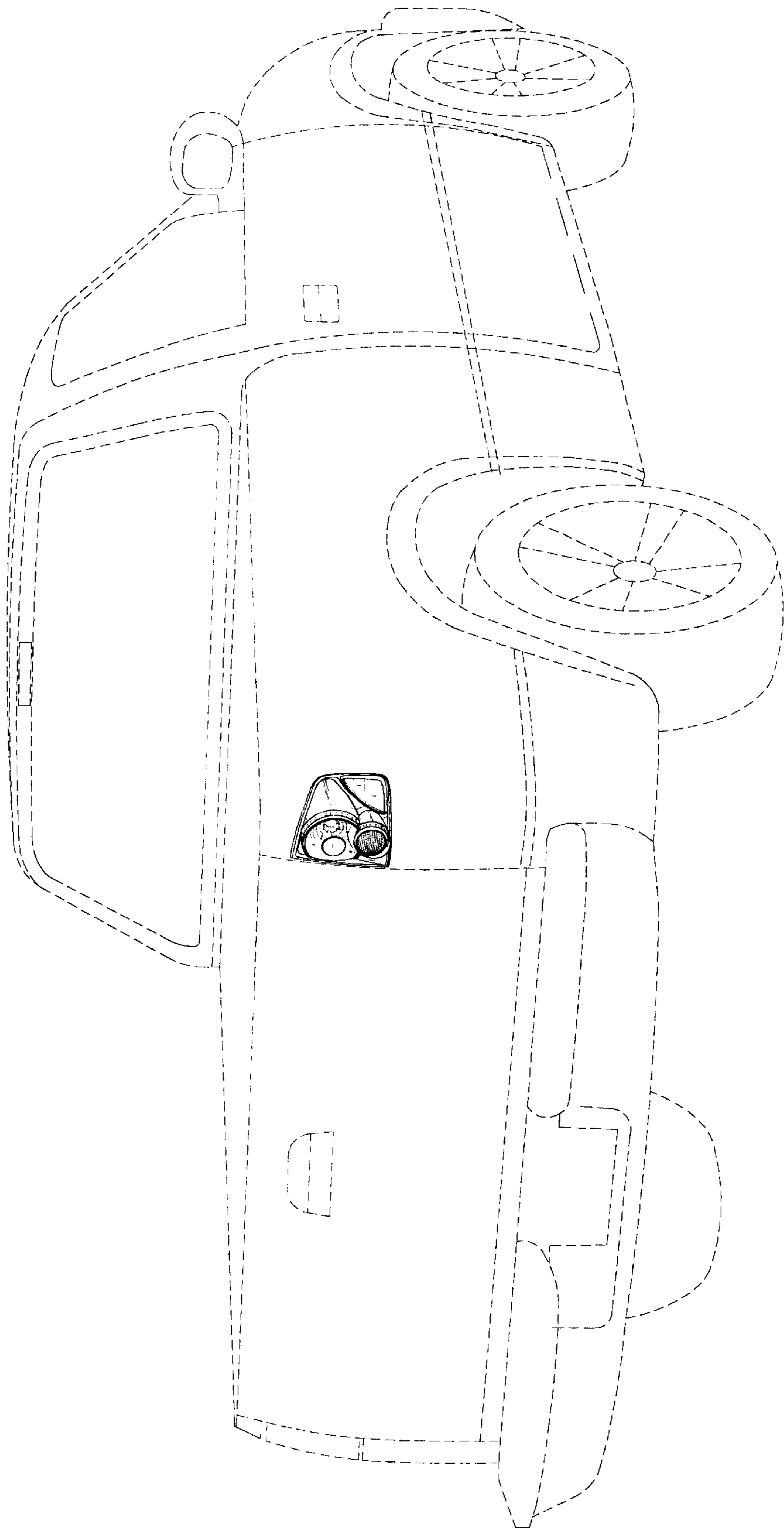

FIG. 5