



US00D476607S

(12) **United States Design Patent**
Stern et al.

(10) **Patent No.:** **US D476,607 S**

(45) **Date of Patent:** **** Jul. 1, 2003**

(54) **STEERING WHEEL**

(75) Inventors: **Peter A. Stern**, San Leandro, CA (US);
John Faust, Burlingame, CA (US);
Fred Swan, Castro Valley, CA (US);
Vance A. Prather, Tracy, CA (US);
David McVicar, El Dorado, CA (US);
Ming Yu, Taipei (TW); **Chau-Chang Chou**, Taichung (TW); **Manuel Tavano**, San Donato Milanese (IT); **Matteo Montani**, Vailate (IT); **Klaus Fiorino**, Magenta (IT)

(73) Assignee: **Logitech Europe S.A.** (CH)

(**) Term: **14 Years**

(21) Appl. No.: **29/161,090**

(22) Filed: **May 21, 2002**

(51) **LOC (7) Cl.** **12-16**

(52) **U.S. Cl.** **D12/176**

(58) **Field of Search** **D12/176, 175;**
74/552, 558, 558.5

(56) **References Cited**

U.S. PATENT DOCUMENTS

D409,538 S	*	5/1999	Isetani et al.	D12/176
D424,000 S	*	5/2000	An et al.	D12/176
D424,488 S	*	5/2000	Thorpe	D12/176
D440,915 S	*	4/2001	Kagawa et al.	D12/176

D463,336 S	*	9/2002	Prather et al.	D12/176
D463,764 S	*	10/2002	Swan et al.	D12/176
D464,595 S	*	10/2002	Zorkendorfer et al.	D12/176

* cited by examiner

Primary Examiner—Melody N. Brown
(74) *Attorney, Agent, or Firm*—Townsend and Townsend and Crew LLP

(57) **CLAIM**

The ornamental design for a steering wheel, as shown and described.

DESCRIPTION

FIG. 1 is a perspective view of a steering wheel showing our new design;
FIG. 2 is a right side elevational view, the left side elevational view being a mirror image thereof;
FIG. 3 is a front elevational view of the wheel portion of the steering wheel taken at line 3—3 thereof;
FIG. 4 is a left side view of the wheel portion of FIG. 3;
FIG. 5 is a top plan view of the body portion of the steering wheel of FIG. 1;
FIG. 6 is a bottom plan view of the body portion of FIG. 5;
FIG. 7 is a front elevational view of the body portion of FIG. 5; and,
FIG. 8 is a rear elevational view of the body portion of FIG. 5.

The broken lines shown throughout the drawing are for illustrative purposes and form no part of the claimed design.

1 Claim, 4 Drawing Sheets

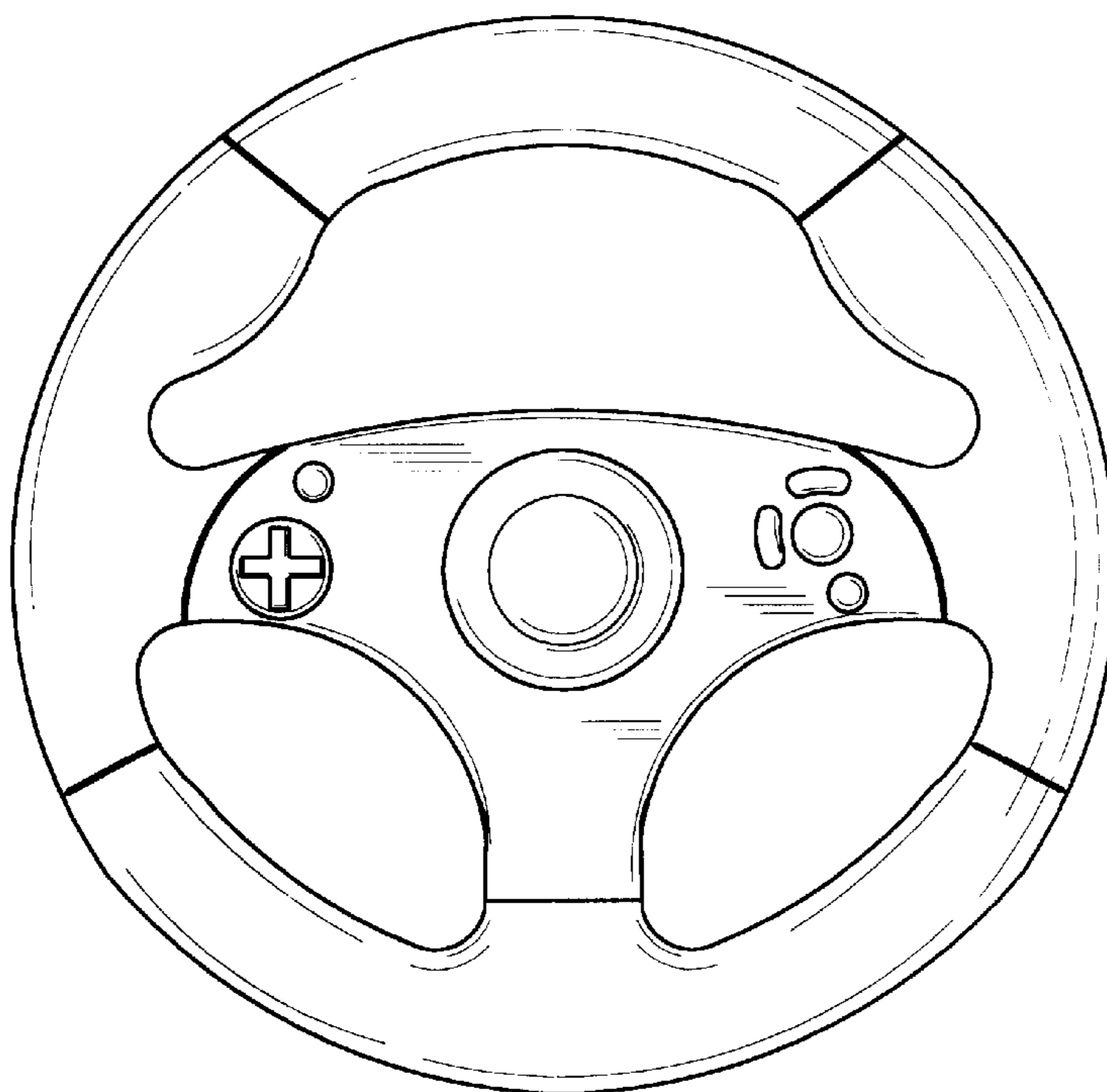

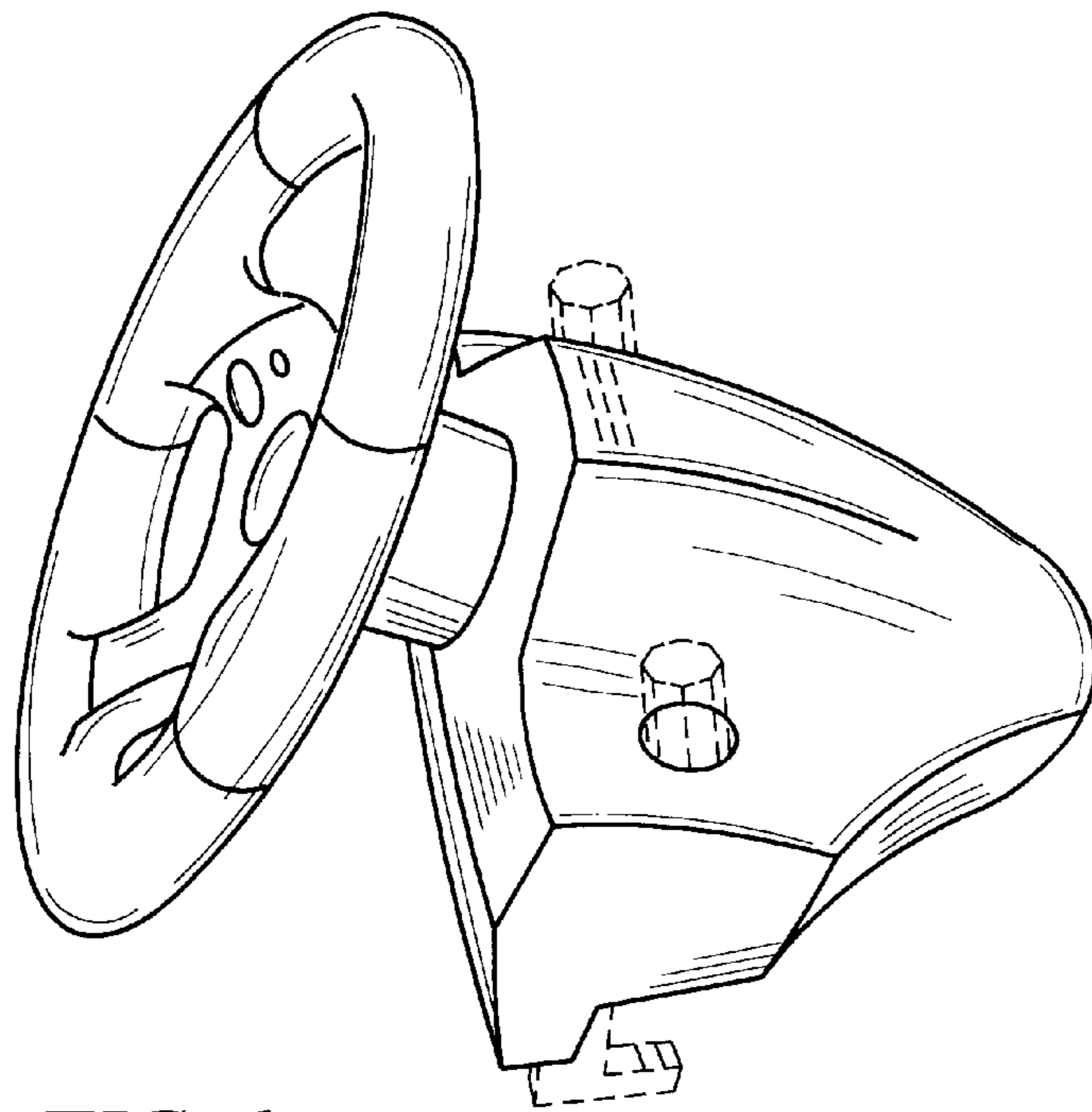

FIG. 1

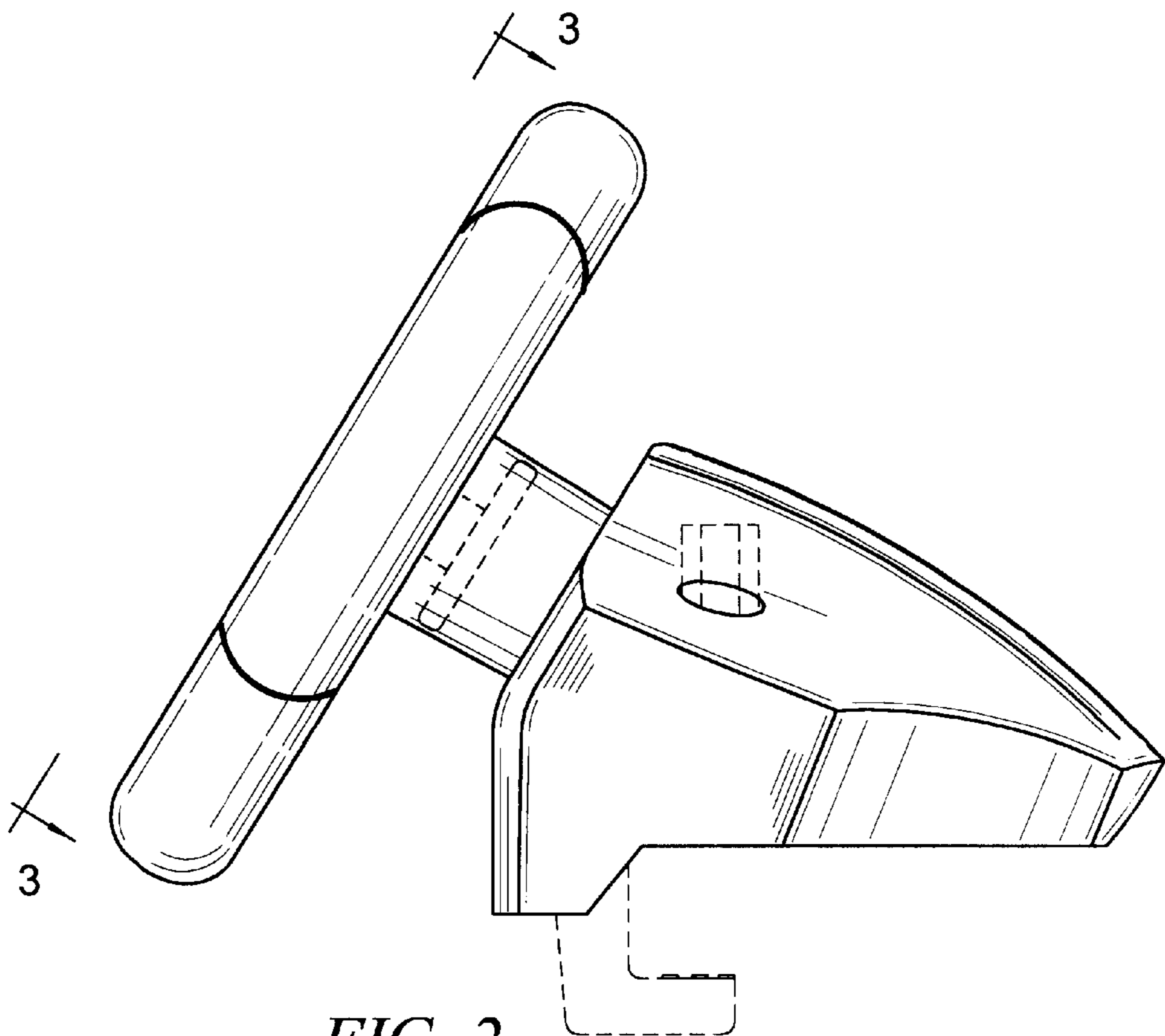

FIG. 2

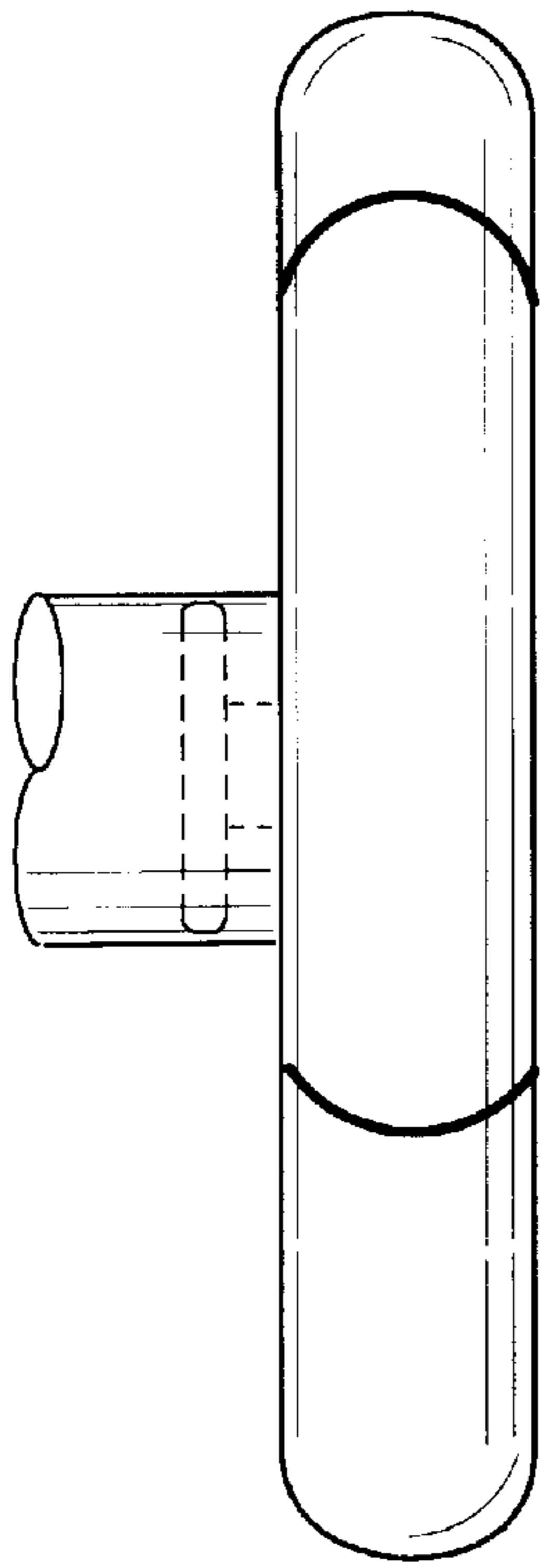

FIG. 4

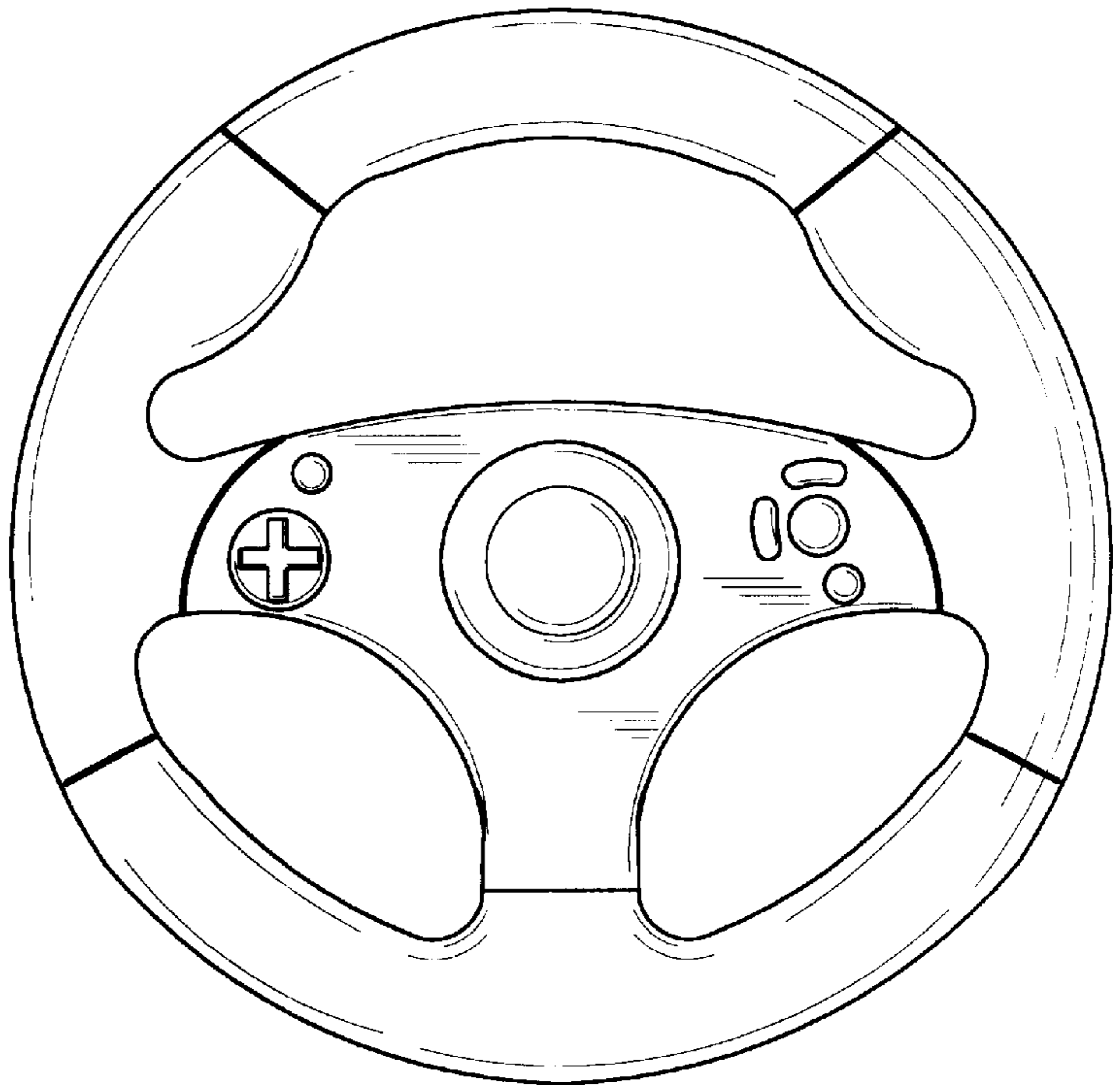

FIG. 3

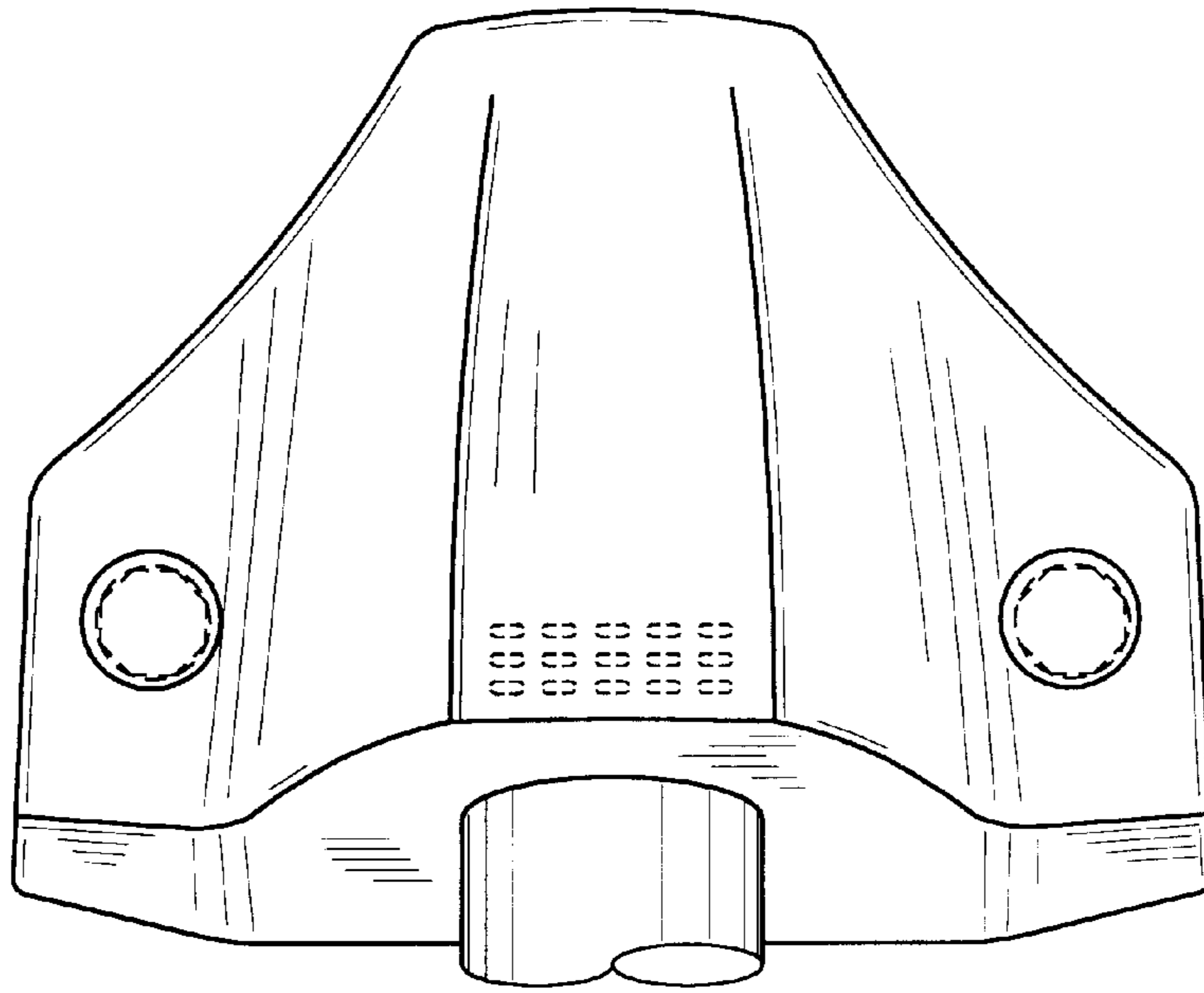

FIG. 5

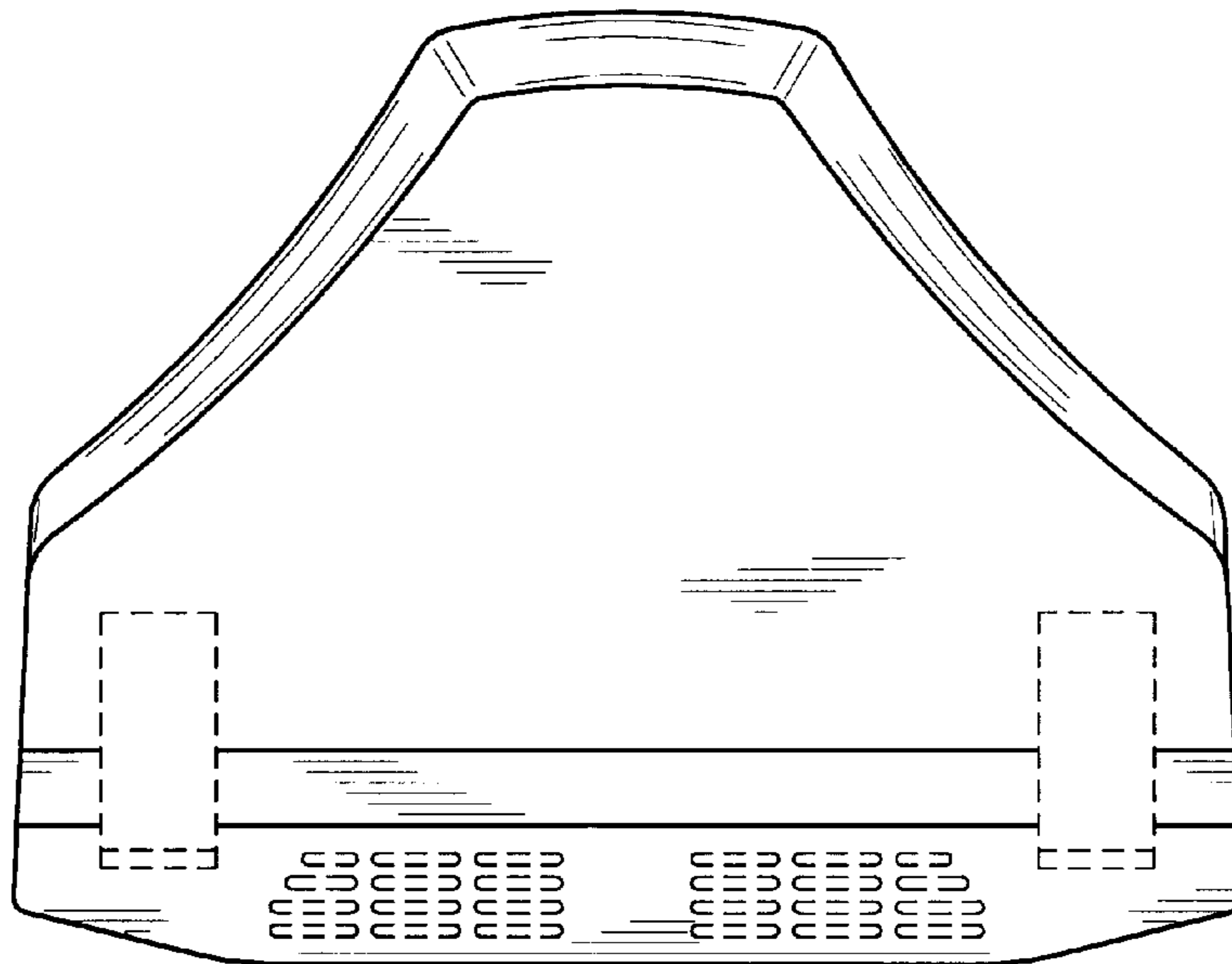

FIG. 6

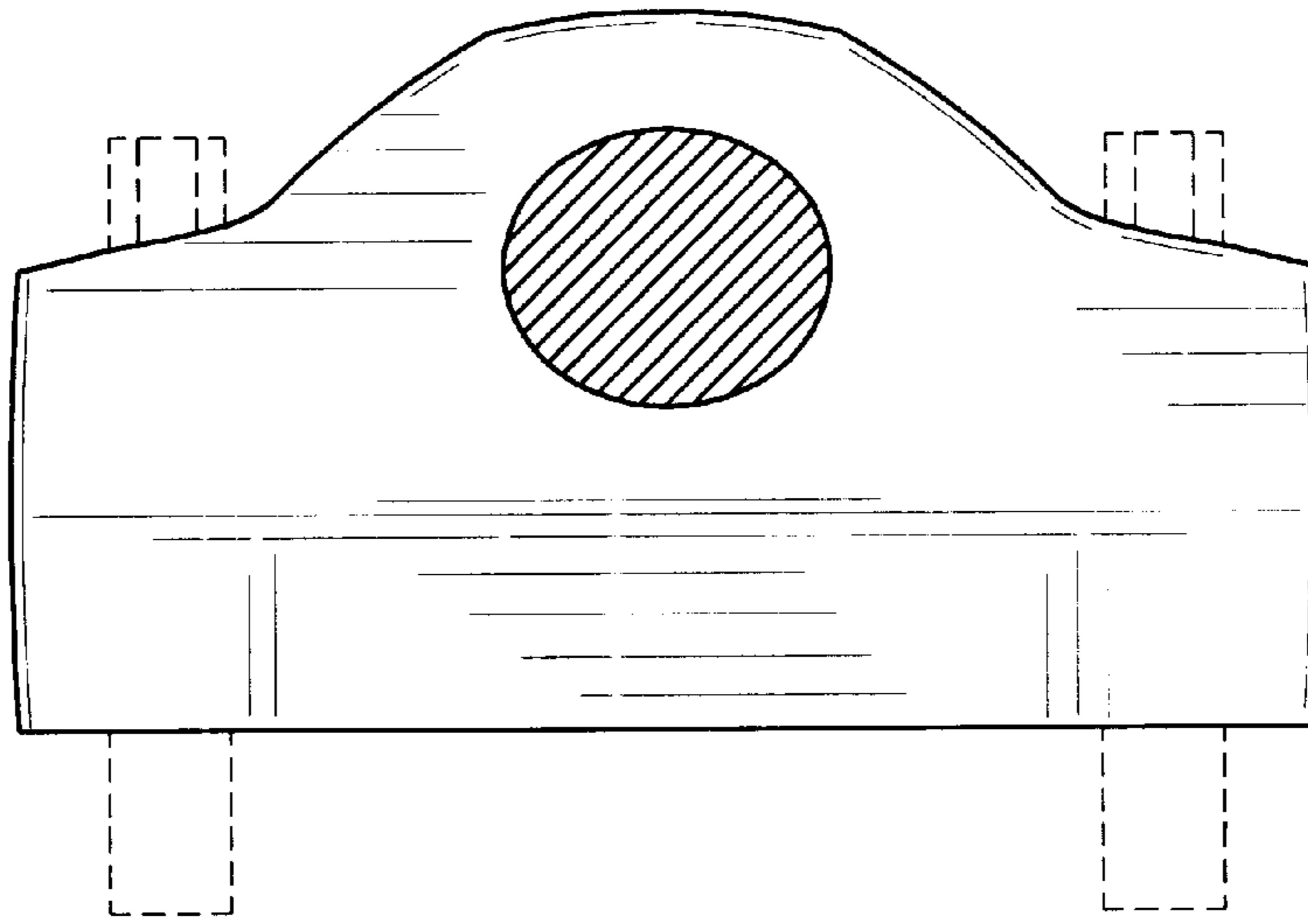

FIG. 7

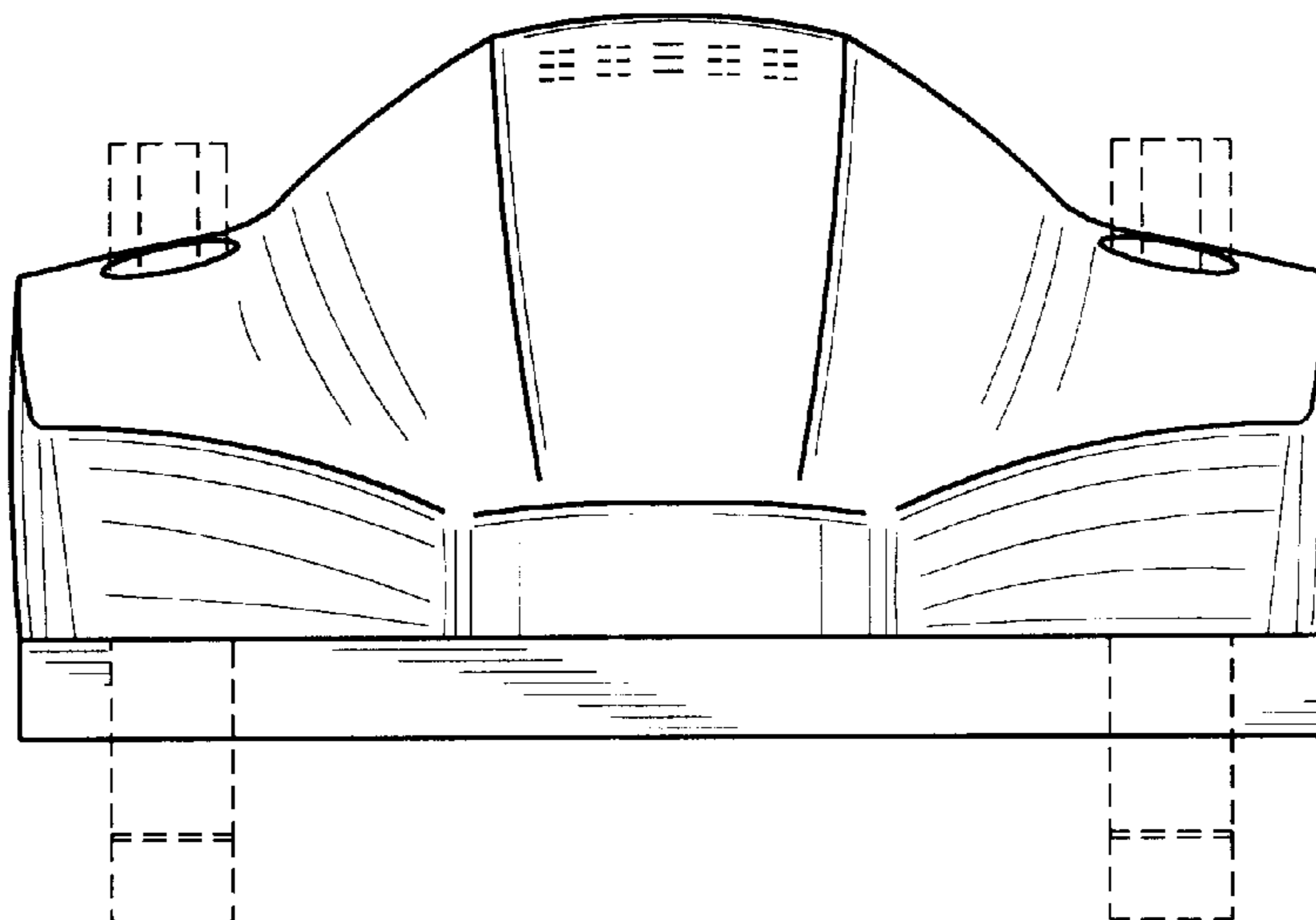

FIG. 8