



US00D476357S

(12) **United States Design Patent**
Gresco

(10) **Patent No.:** **US D476,357 S**

(45) **Date of Patent:** **** Jun. 24, 2003**

(54) **STRAP FOR MUSICAL INSTRUMENT**

DESCRIPTION

(76) Inventor: **Roger A. Gresco**, 1421 San Bernardino,
#39-D, Upland, CA (US) 91786

(**) Term: **14 Years**

(21) Appl. No.: **29/148,586**

(22) Filed: **Sep. 24, 2001**

(51) **LOC (7) Cl.** **17-03**

(52) **U.S. Cl.** **D17/20; D2/624**

(58) **Field of Search** **D2/624, 627, 629;**
D3/327; D17/20, 99; 84/327; 224/257,
258, 264, 910

(56) **References Cited**

U.S. PATENT DOCUMENTS

3,688,012 A *	8/1972	Vettel	84/327
D249,386 S *	9/1978	Zacuto	D17/20
4,254,901 A *	3/1981	McIntosh	224/258
4,291,822 A *	9/1981	Simonds	224/257
6,250,525 B1 *	6/2001	Lehoux	224/257
D462,710 S *	9/2002	Babcock	D17/20

* cited by examiner

Primary Examiner—Adir Aronovich

(57) **CLAIM**

The ornamental design for a strap for musical instrument, as shown and described.

FIG. 1 is a top plan view of a strap for musical instrument showing my new design;
 FIG. 2 is a side edge view thereof;
 FIG. 3 is an edge view of the side edge opposite from the view of FIG. 2;
 FIG. 4 is a bottom view thereof;
 FIG. 5 is an end view thereof;
 FIG. 6 is an end view opposite that from FIG. 5;
 FIG. 7 is a sectional view taken at line 7—7 in FIG. 1;
 FIG. 8 is a top plan view of a second embodiment of the design of FIG. 1;
 FIG. 9 is a side edge view of FIG. 8;
 FIG. 10 is an edge view of the side edge opposite from the view of FIG. 9;
 FIG. 11 is a bottom view of FIG. 8;
 FIG. 12 is an end view of FIG. 8;
 FIG. 13 is an end view opposite that from FIG. 12;
 FIG. 14 is a sectional view taken at line 14—14 in FIG. 8;
 FIG. 15 is a top plan view of a third embodiment of the design of FIG. 1;
 FIG. 16 is a side edge view of FIG. 15;
 FIG. 17 is an edge view of the side edge opposite from the view of FIG. 16;
 FIG. 18 is a bottom view of FIG. 15;
 FIG. 19 is an end view of FIG. 15;
 FIG. 20 is an end view opposite that from FIG. 19; and,
 FIG. 21 is a sectional view taken at line 21—21 in FIG. 15.
 The broken lines shown at the ends of FIGS. 1, 8 and 15 are for illustrative purposes only and form no part of the claimed design.

The broken lines shown in FIGS. 1, 4, 8, 11, 15 and 18 are representative of conventional stitching.

1 Claim, 3 Drawing Sheets

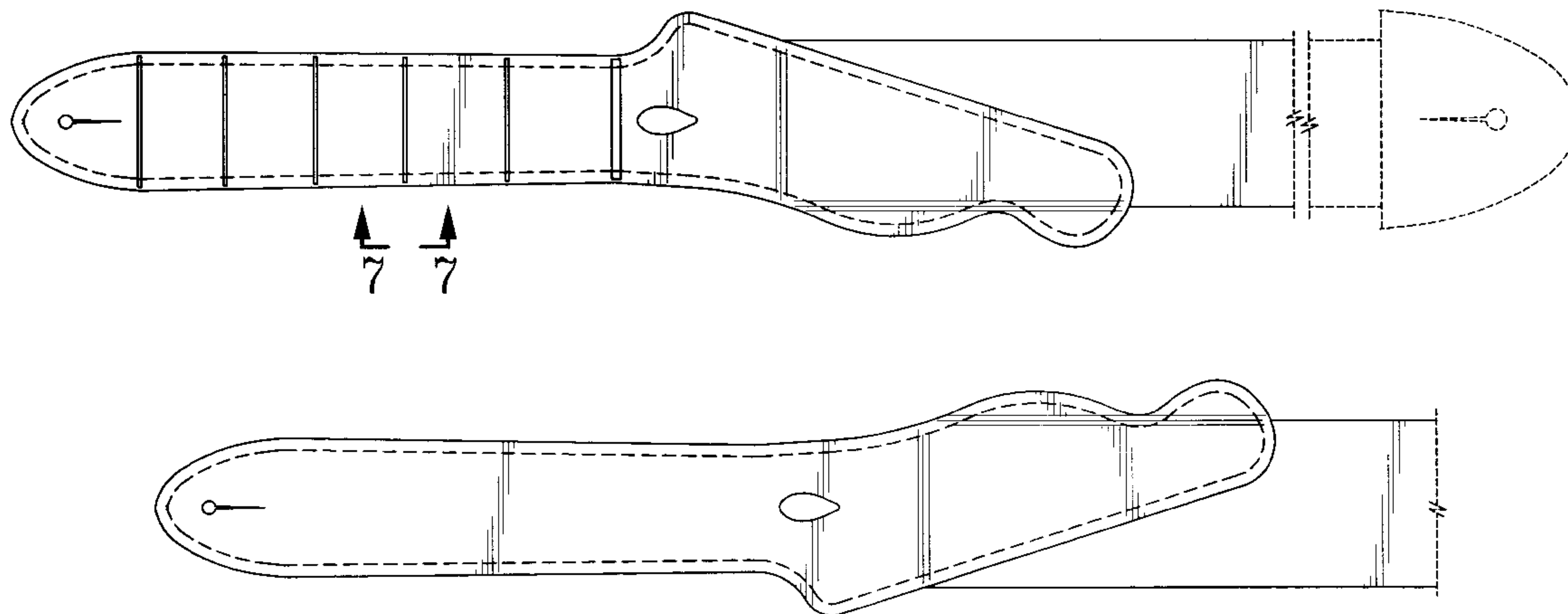

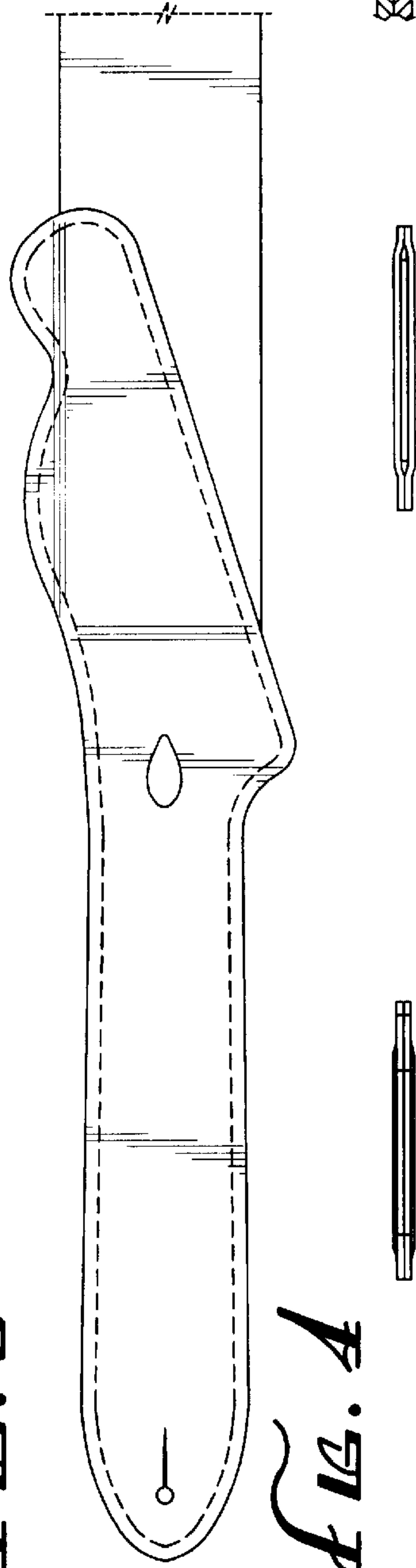
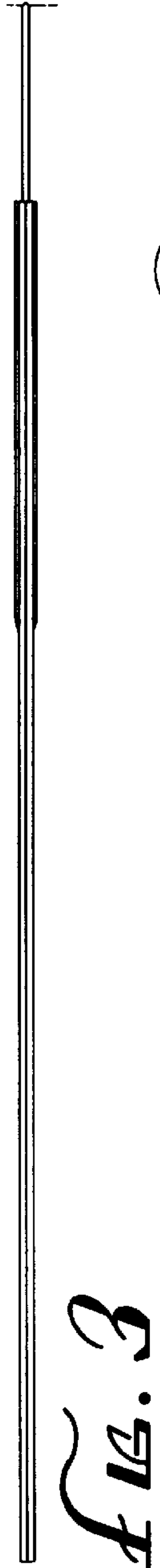
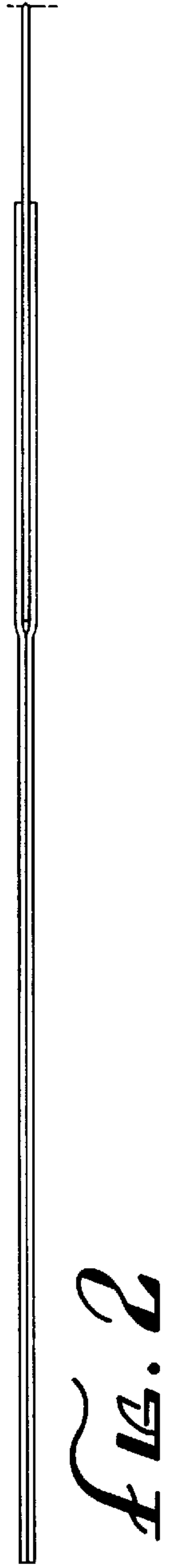
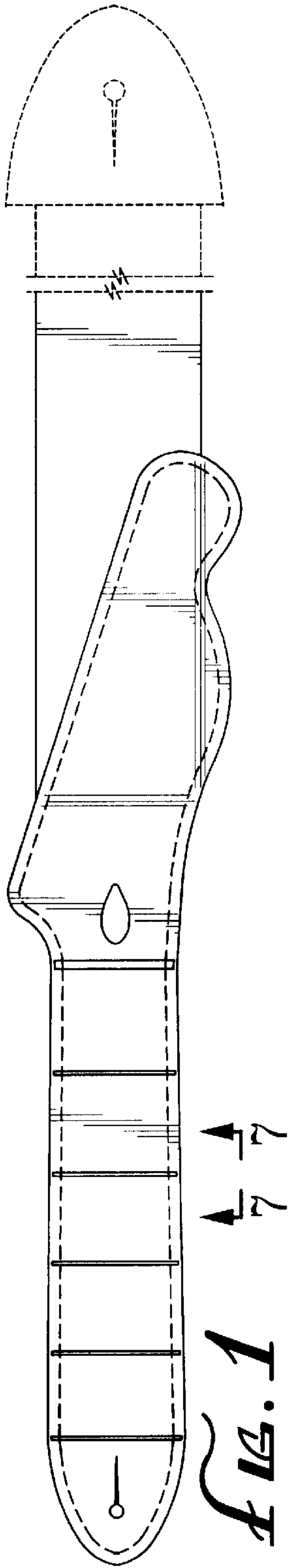

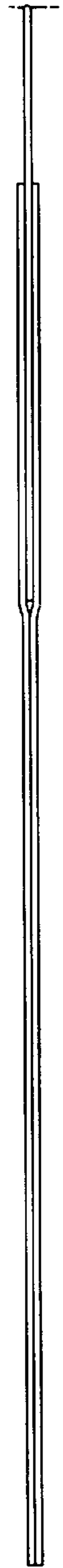
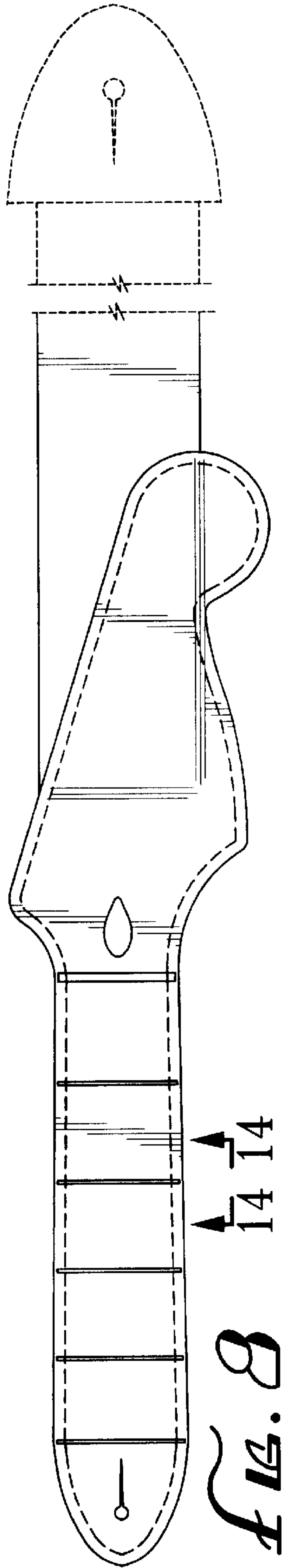

FIG. 9



FIG. 10

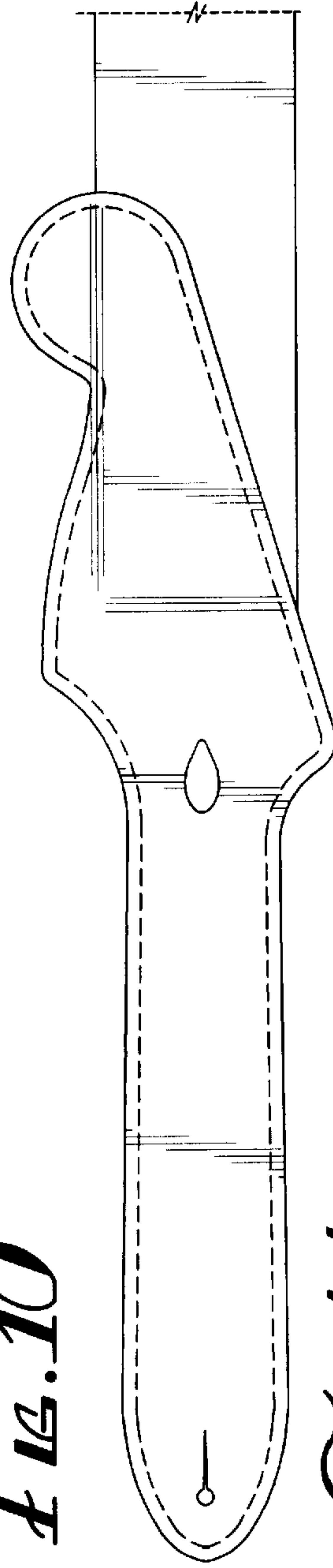

FIG. 11

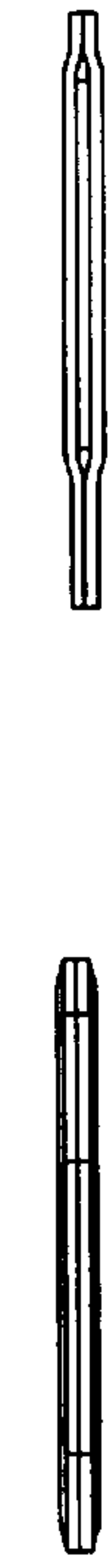

FIG. 12



FIG. 13



FIG. 14

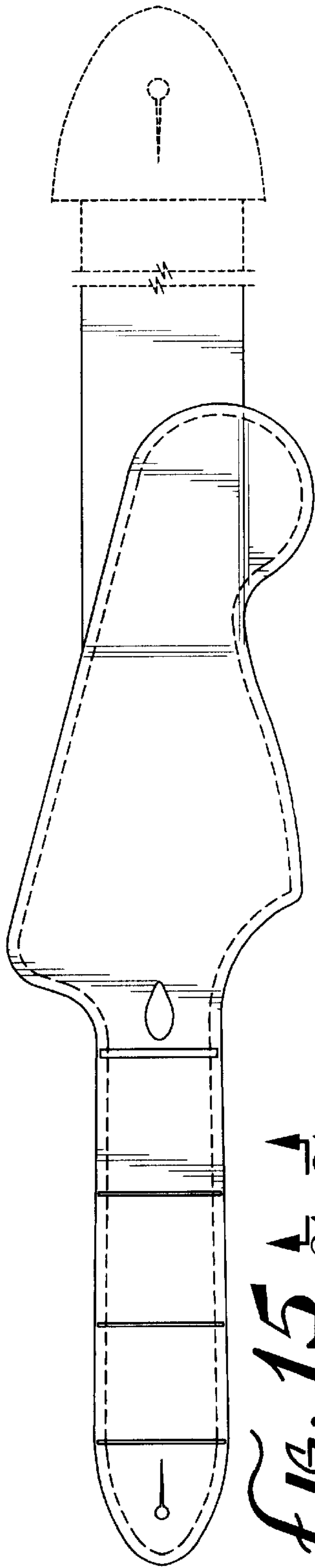

FIG. 15



FIG. 16



FIG. 17

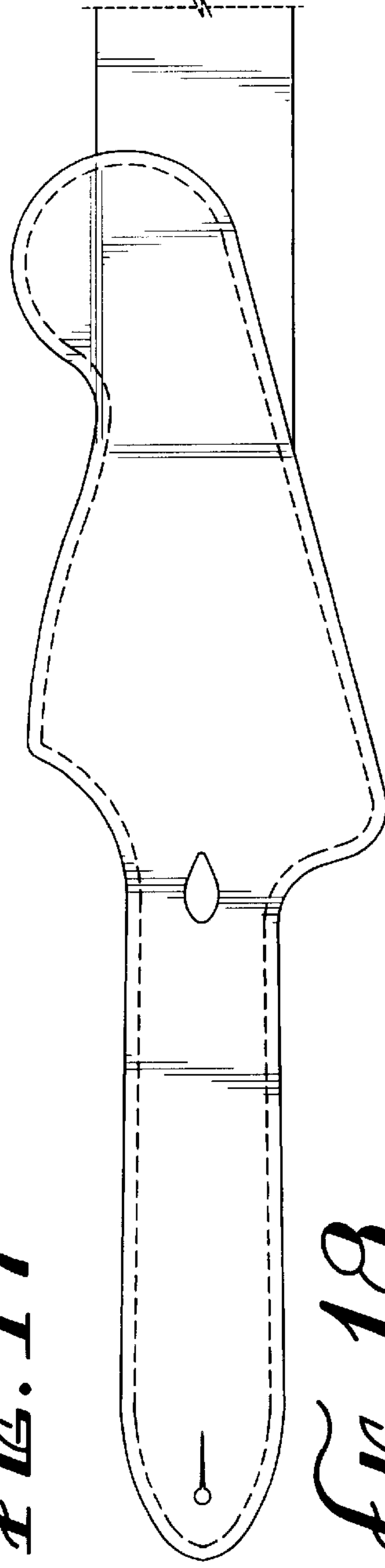

FIG. 18



FIG. 19



FIG. 20



FIG. 21