



US00D476289S

(12) **United States Design Patent**
Kendall et al.

(10) **Patent No.:** **US D476,289 S**

(45) **Date of Patent:** **** Jun. 24, 2003**

(54) **SUN POWERED AIRCRAFT**

D458,892 S * 6/2002 DeTore et al. D12/319

(75) Inventors: **Greg T. Kendall**, Simi Valley, CA (US); **James G. Daley**, Ventura, CA (US); **Bart D. Hibbs**, Altadena, CA (US); **Rik D. Meininger**, Simi Valley, CA (US); **Laird Owens**, Simi Valley, CA (US); **William M. Parks**, Simi Valley, CA (US); **Adam L. Peltz**, Oxnard, CA (US); **Wyatt Sadler**, Simi Valley, CA (US); **Mark Shipley**, Thousand Oaks, CA (US)

* cited by examiner

Primary Examiner—Marcus A. Jackson
(74) *Attorney, Agent, or Firm*—William W. Haefliger

(73) Assignee: **Aerovironment Inc.**, Monrovia, CA (US)

(**) Term: **14 Years**

(21) Appl. No.: **29/148,129**

(22) Filed: **Sep. 12, 2001**

(51) **LOC (7) Cl.** **12-12**

(52) **U.S. Cl.** **D12/319**

(58) **Field of Search** D12/319; 416/34, 416/35, 61; 244/6, 7 C, 7 R, 12.4, 17.23, 56, 66, 69

(56) **References Cited**

U.S. PATENT DOCUMENTS

5,381,985 A * 1/1995 Wechsler et al. D12/319
D388,392 S * 12/1997 McGinnis et al. D12/319

(57) **CLAIM**

The ornamental design for a sun powered aircraft, as shown and described.

DESCRIPTION

FIG. 1 is a top plan view of an aircraft embodying the new design;
FIG. 2 is a front elevation view of the FIG. 1 aircraft;
FIG. 3 is a left side elevation view of the FIG. 1 aircraft;
FIG. 4 is a right side elevation view of the FIG. 1 aircraft;
FIG. 5 is a rear elevation view of the FIG. 1 aircraft;
FIG. 6 is a bottom view of the FIG. 1 aircraft;
FIG. 7 is a top plan view of a modified aircraft embodying the new design, which is preferred;
FIG. 8 is a front elevation view of the FIG. 7 aircraft;
FIG. 9 is a left side elevation view of the FIG. 7 aircraft;
FIG. 10 is a right side elevation view of the FIG. 7 aircraft;
FIG. 11 is a rear elevation view of the FIG. 7 aircraft;
FIG. 12 is a bottom view of the FIG. 7 aircraft;
FIG. 13 is a perspective view of the aircraft shown in FIGS. 1-6; and,
FIG. 14 is a perspective view of the aircraft shown in FIGS. 1-12.

1 Claim, 7 Drawing Sheets

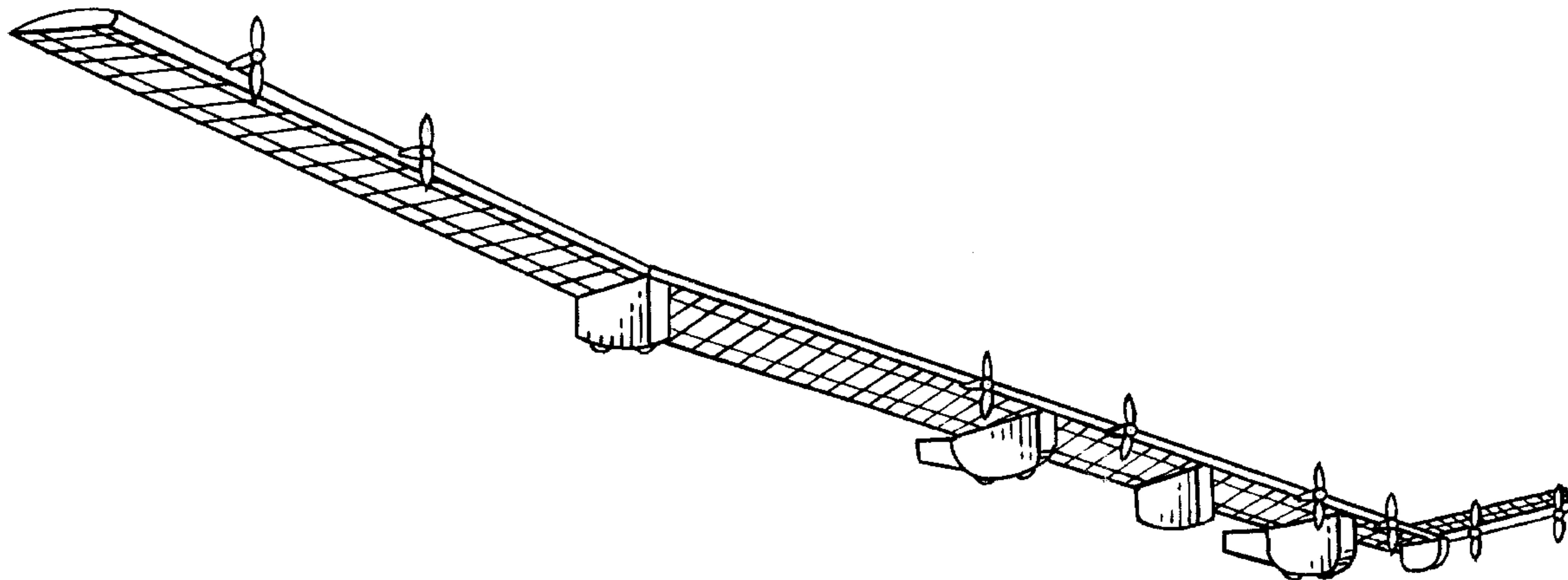

FIG. 1.

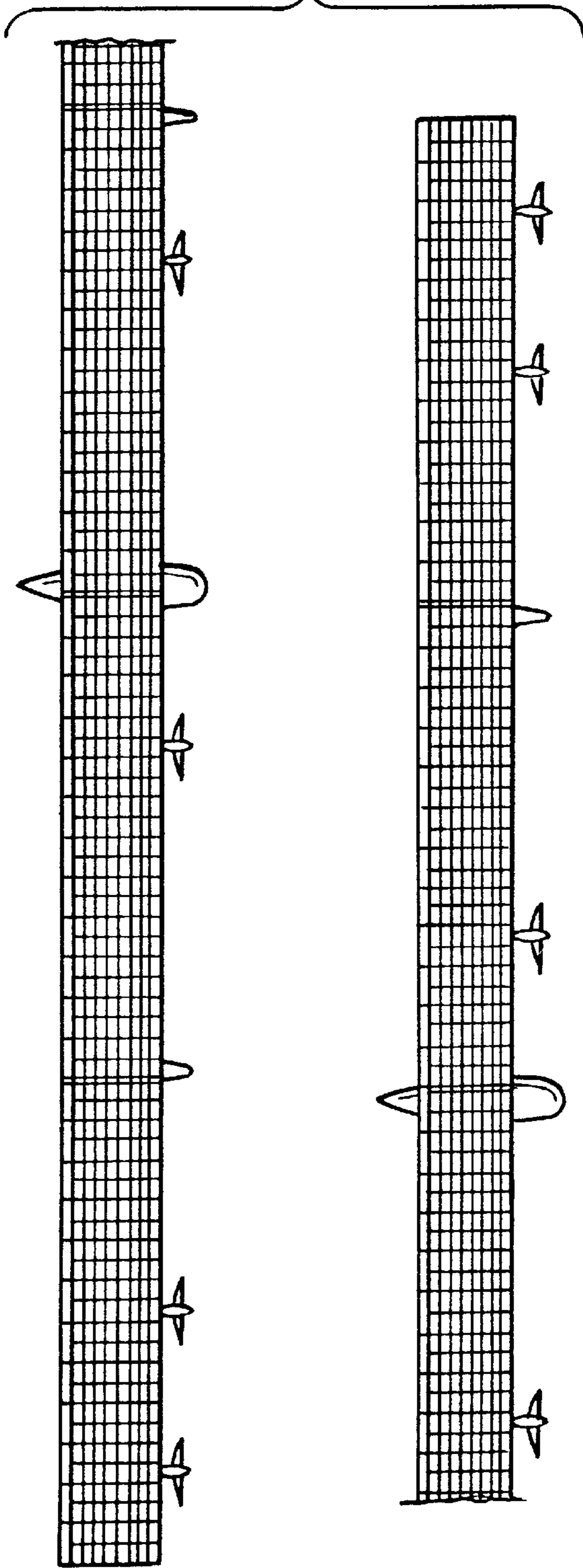

FIG. 2.

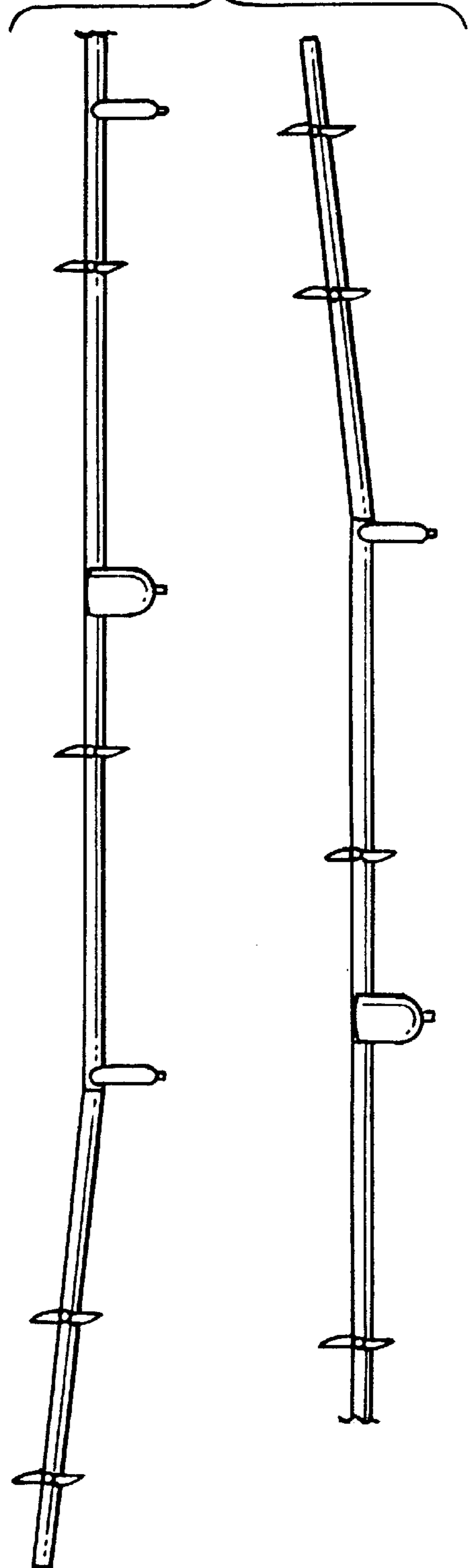

FIG. 3.

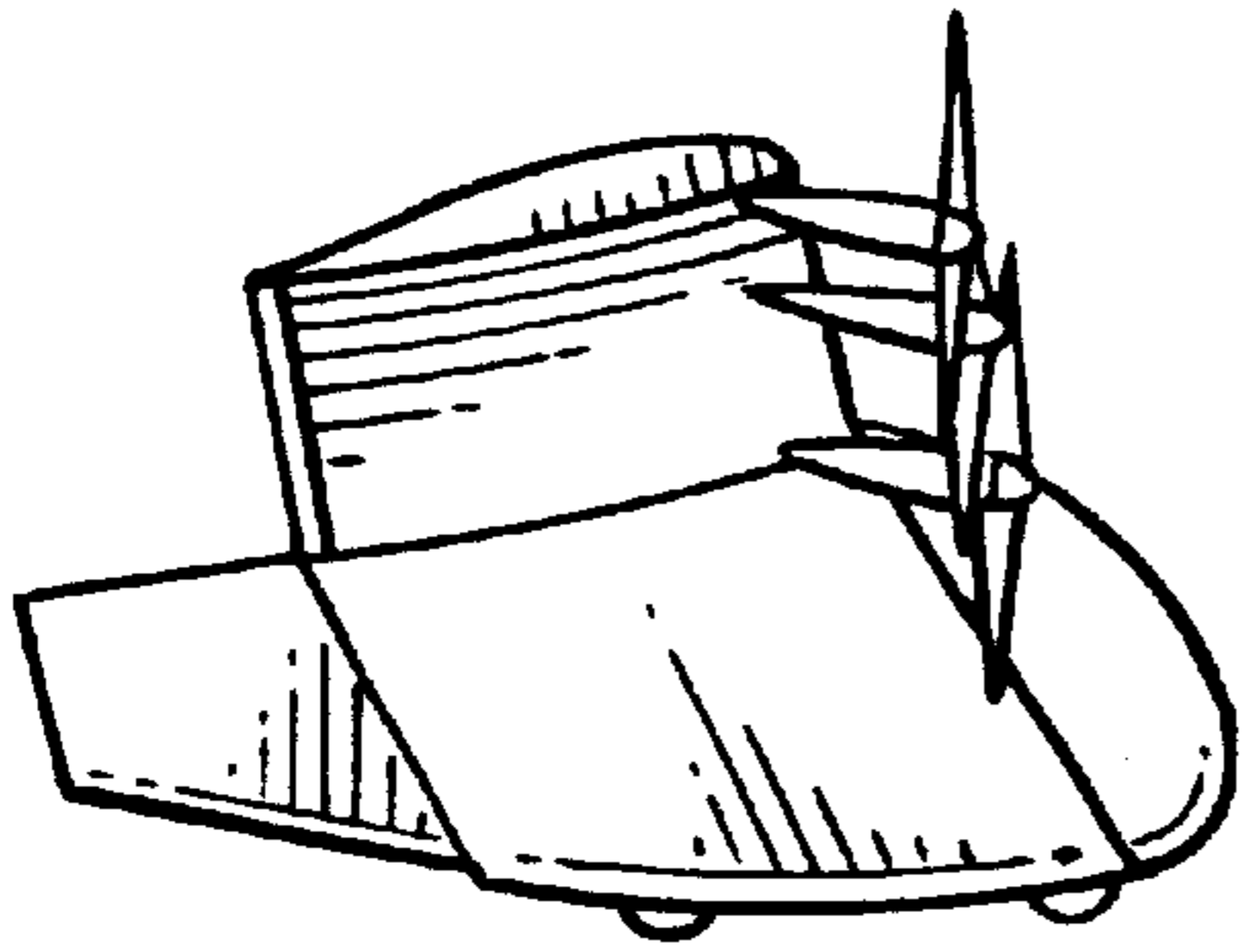

FIG. 4.

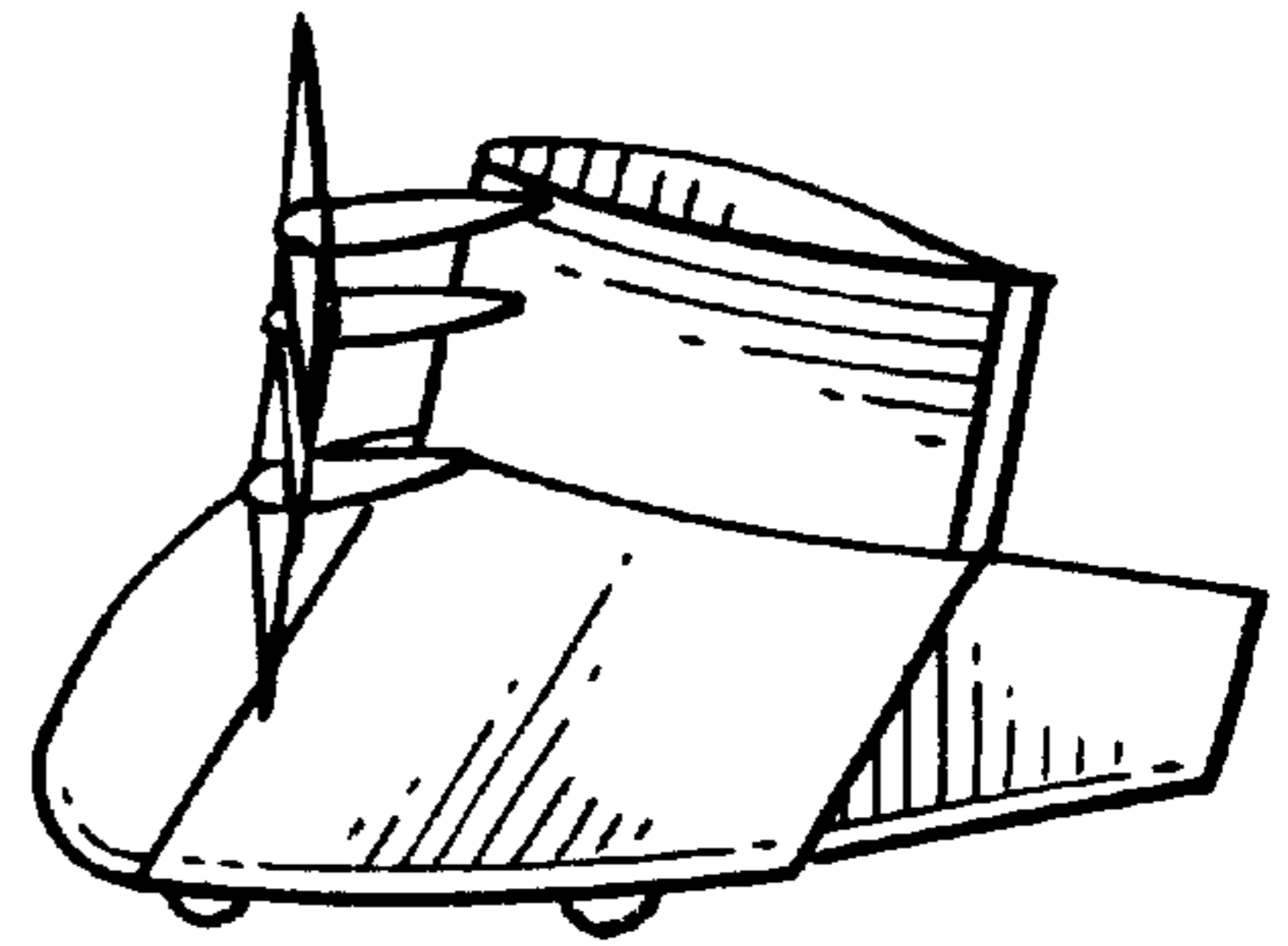

FIG. 9.

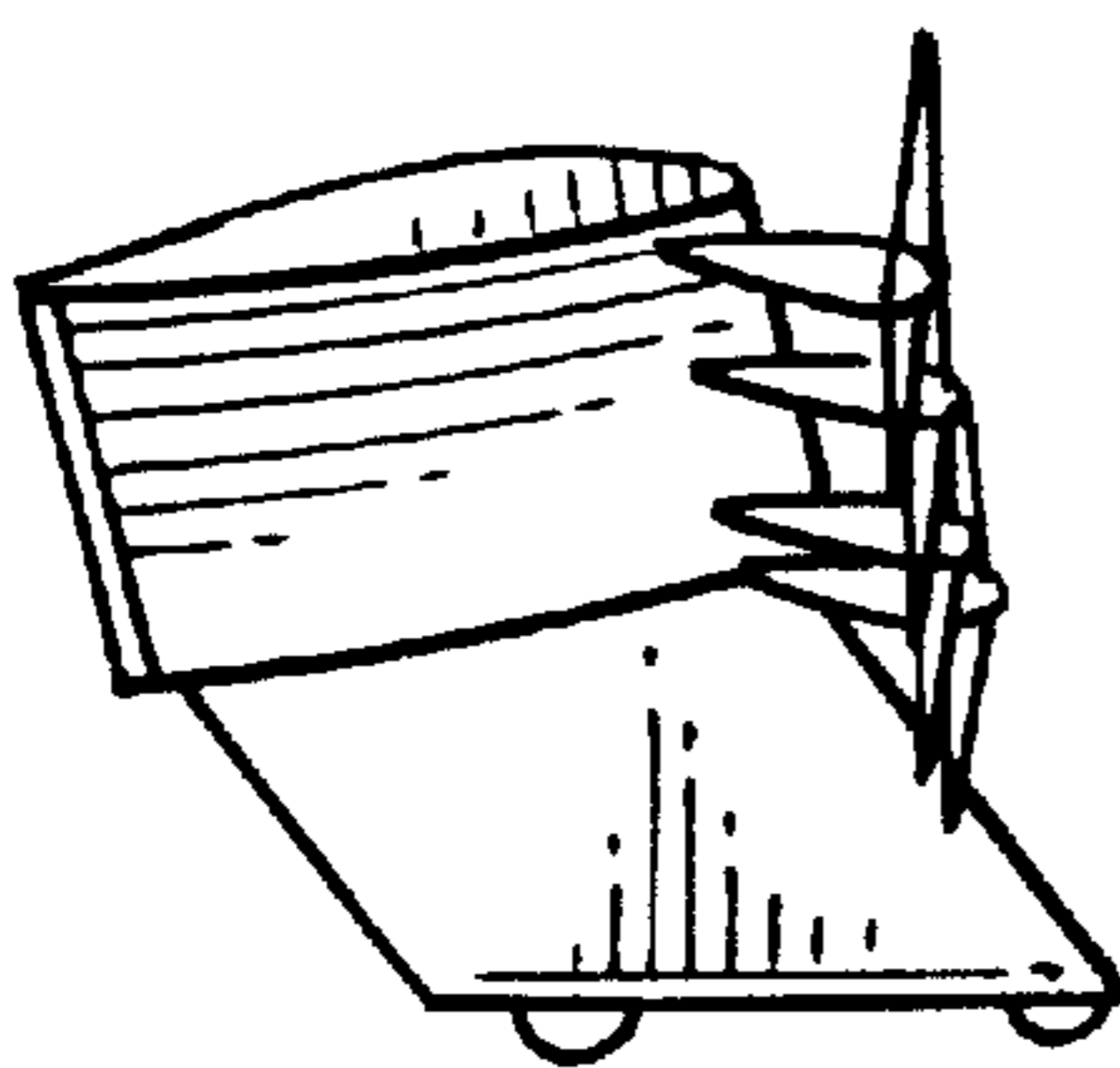
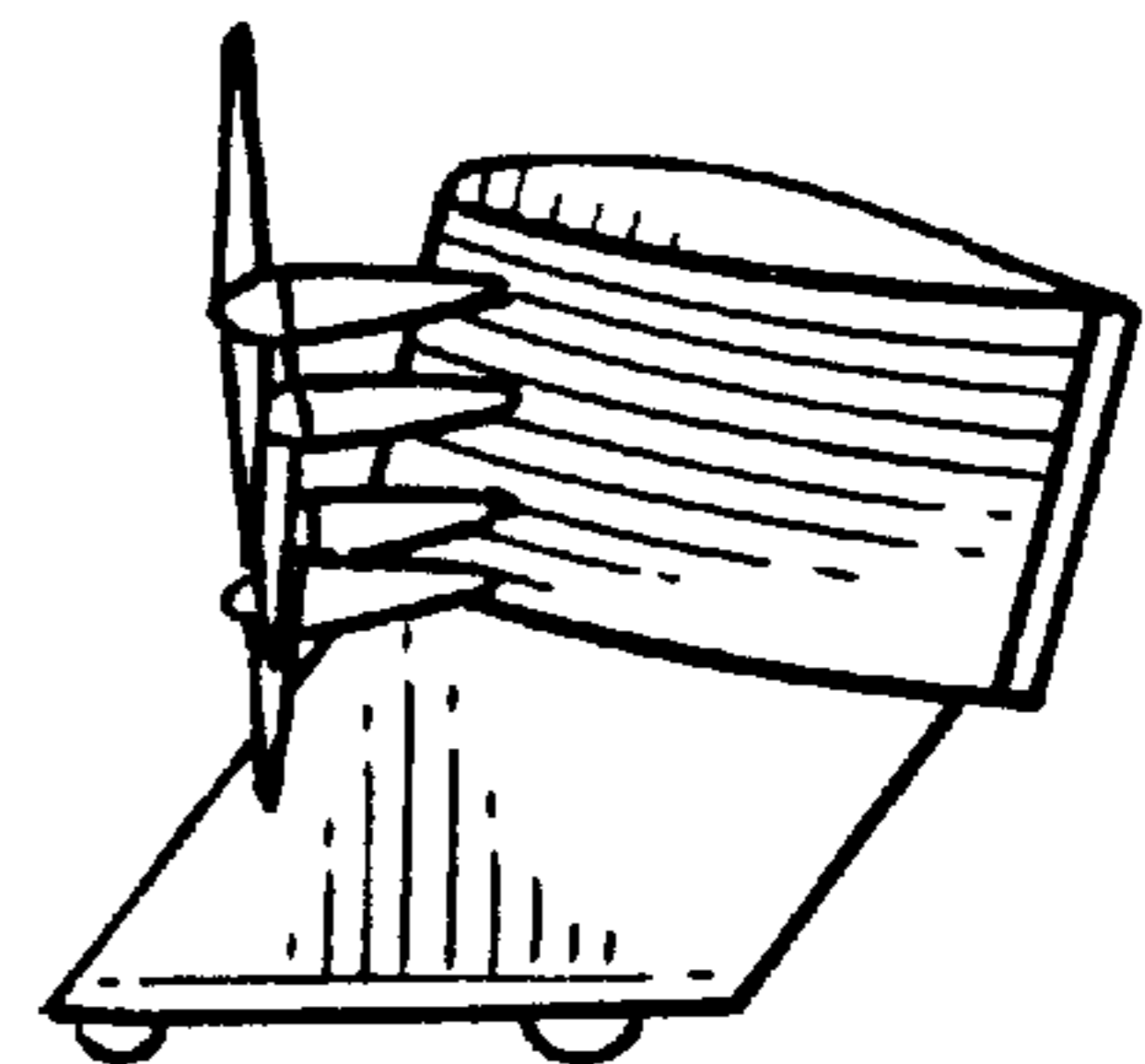

FIG. 10.



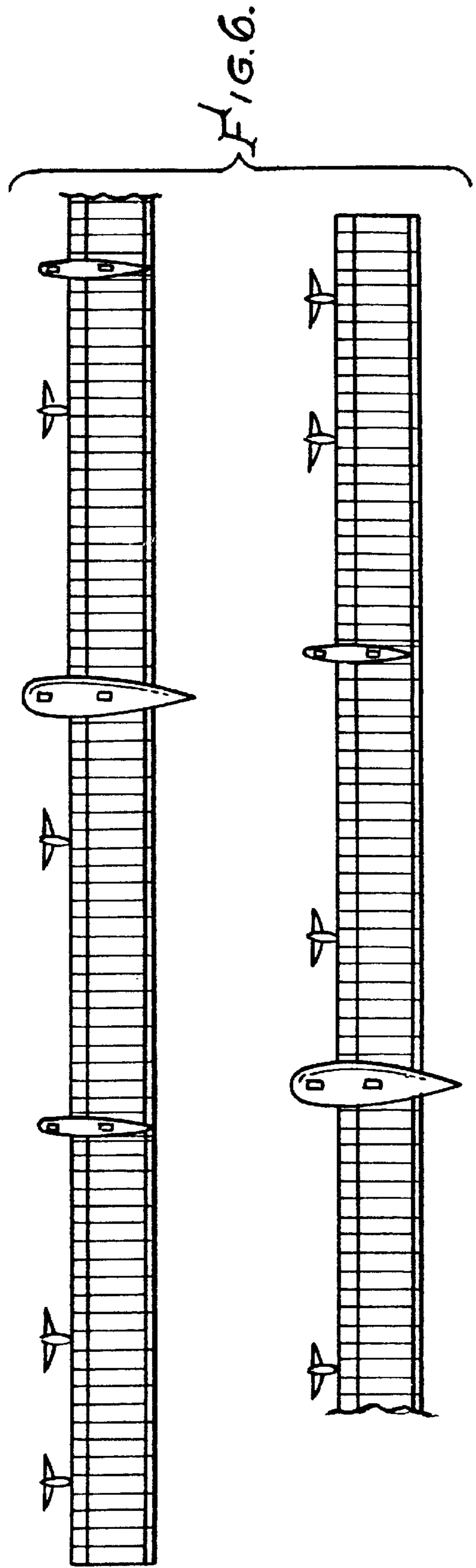
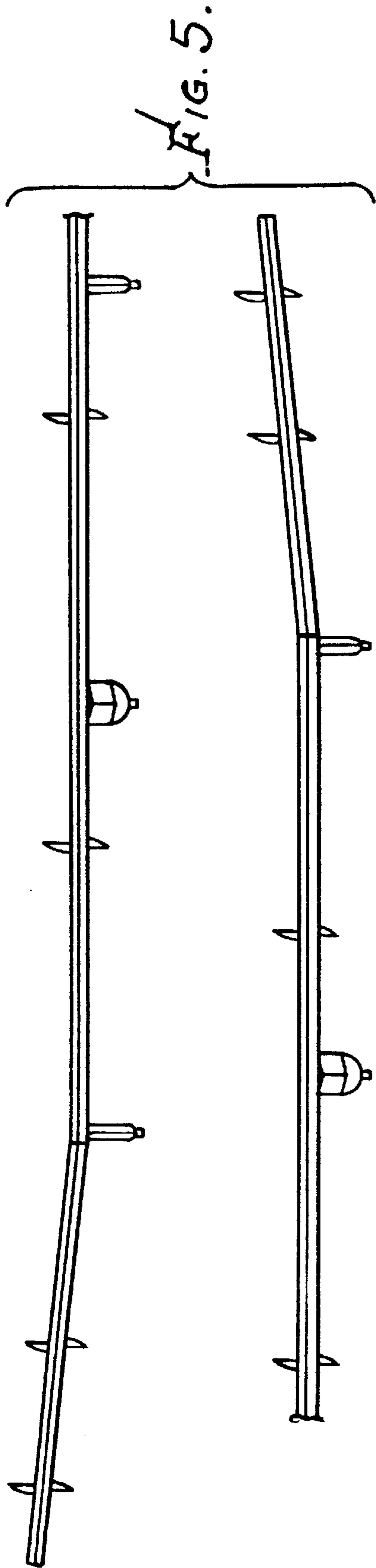

FIG. 7.

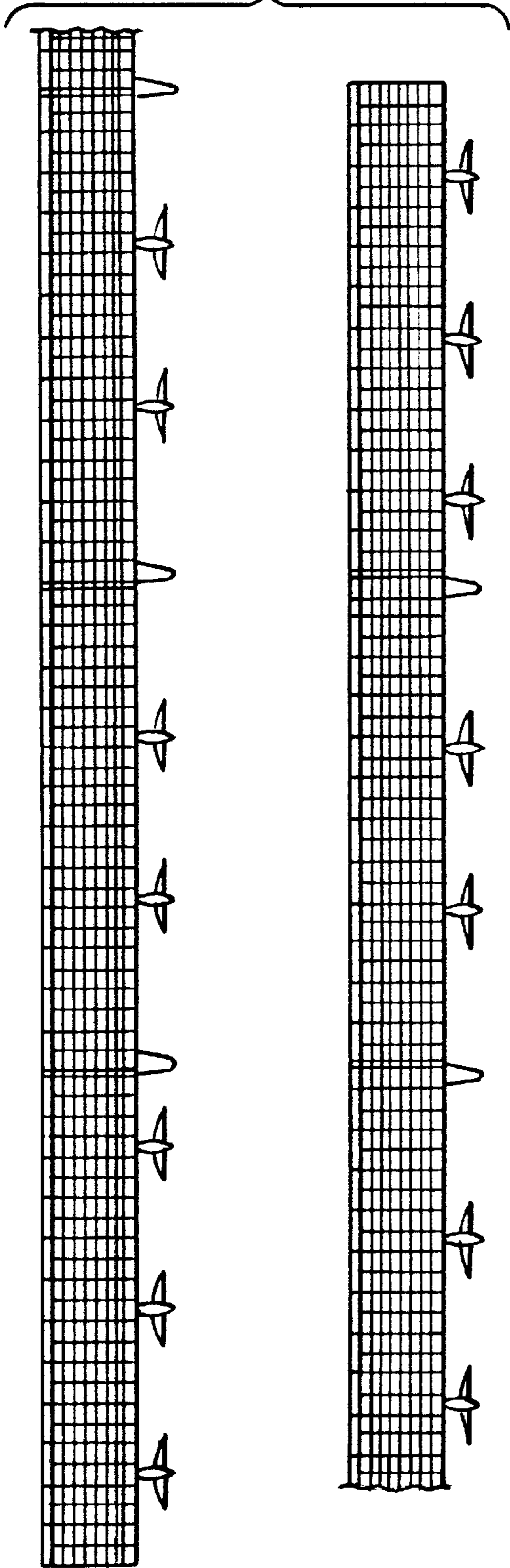

FIG. 8.

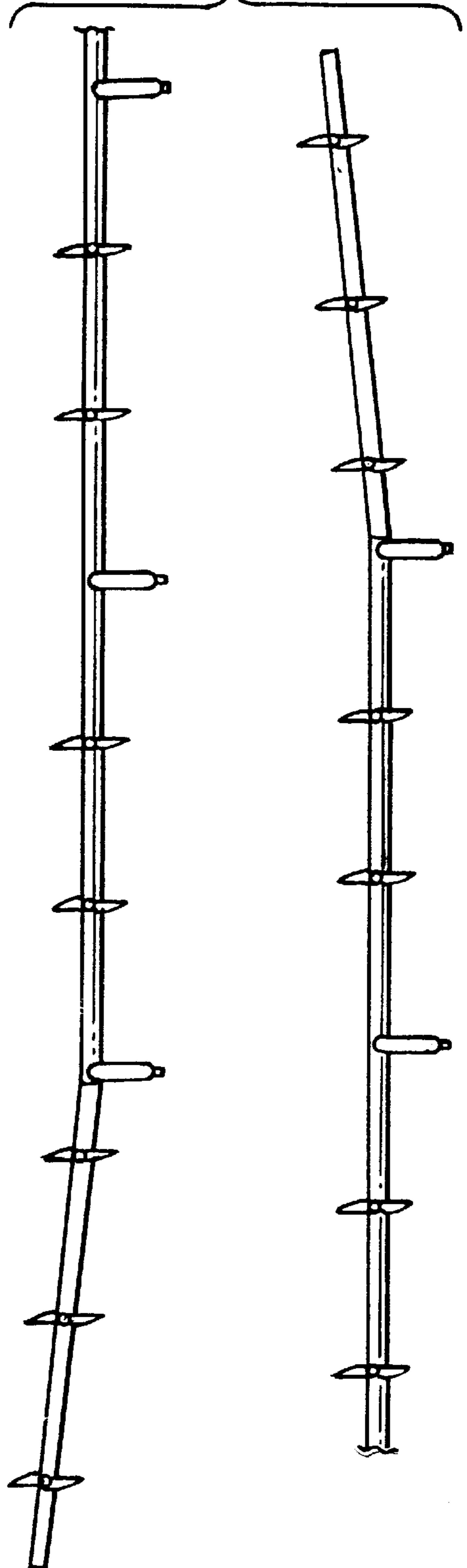

FIG. 11.

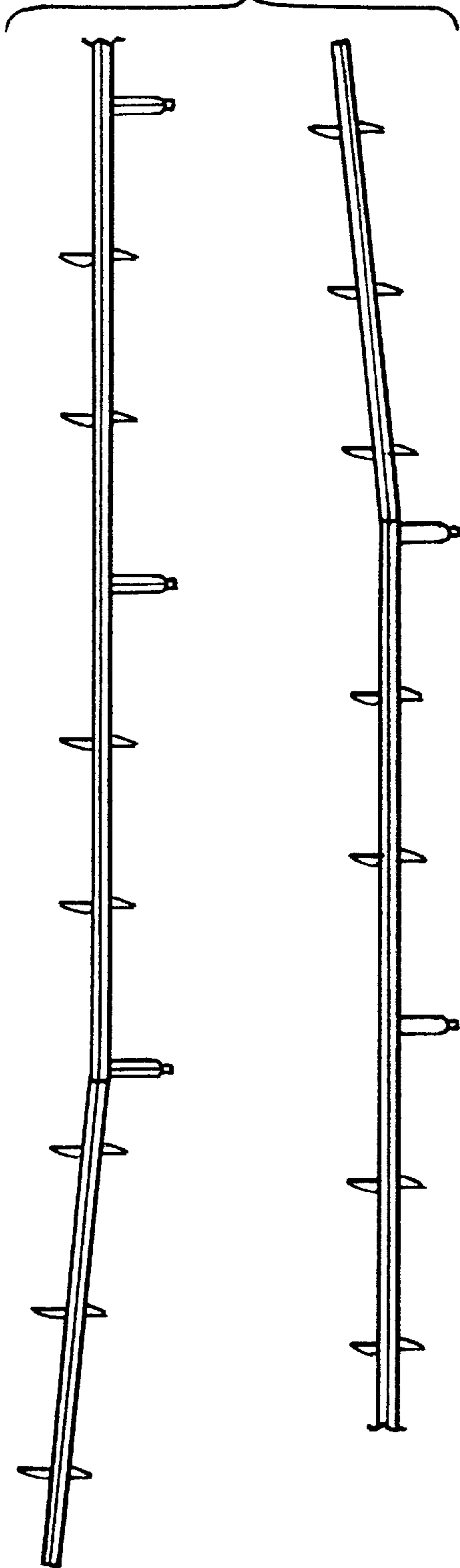

FIG. 12.

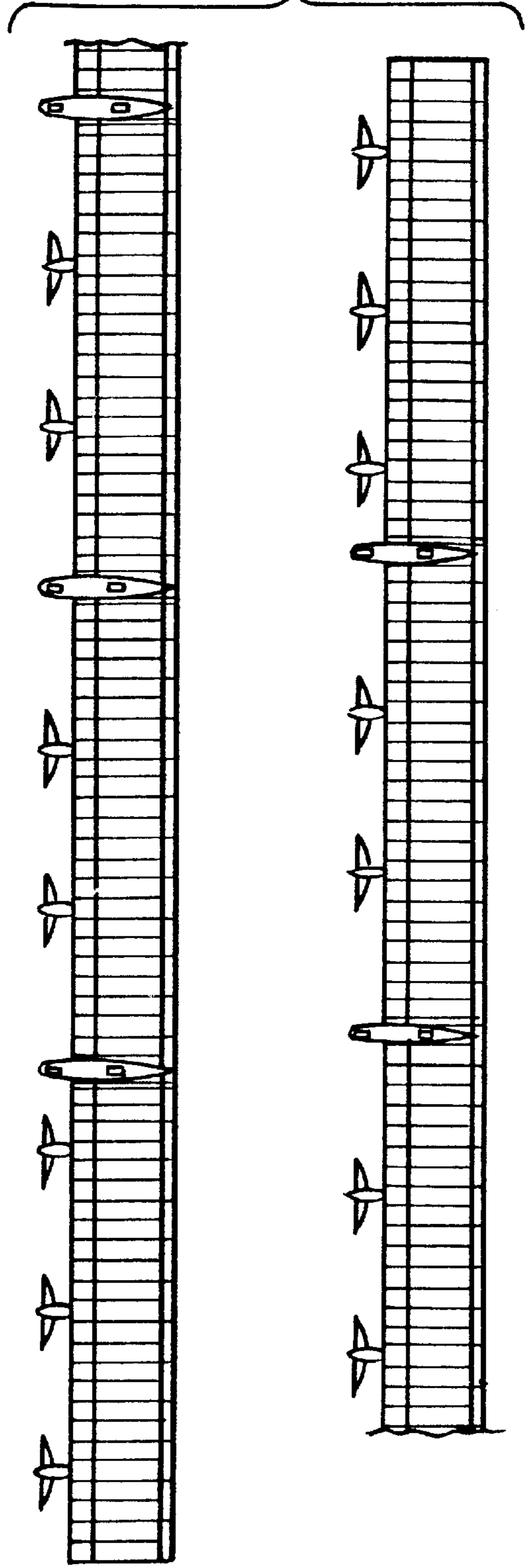

FIG. 13.

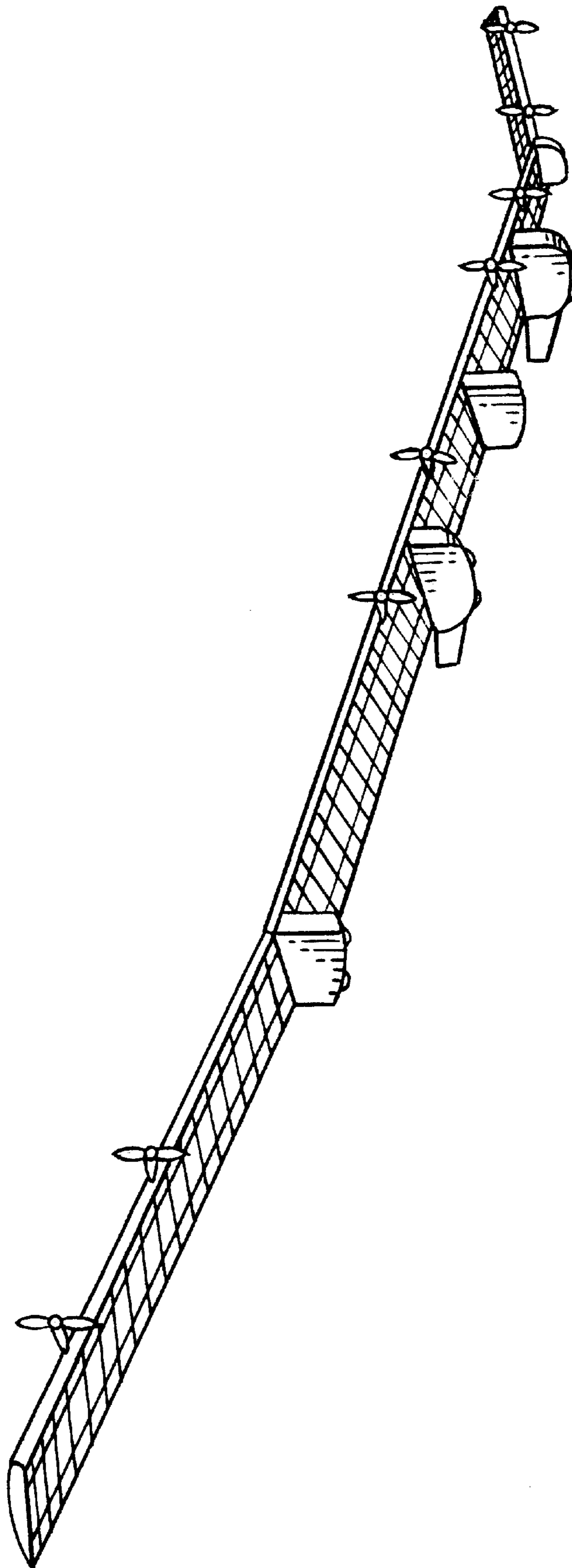

FIG. 14.

