



US00D476287S

(12) **United States Design Patent**  
**Streight**

(10) **Patent No.:** **US D476,287 S**

(45) **Date of Patent:** **\*\* Jun. 24, 2003**

(54) **RACING BOAT**

(76) **Inventor:** **Shane J. Streight**, 320 Shamrock Blvd., Venice, FL (US) 34293

(\*\*) **Term:** **14 Years**

(21) **Appl. No.:** **29/162,346**

(22) **Filed:** **Jun. 12, 2002**

(51) **LOC (7) Cl.** ..... **12-06**

(52) **U.S. Cl.** ..... **D12/300**

(58) **Field of Search** ..... D12/300; 114/283, 114/61, 274, 56, 270-271, 288-291

(56) **References Cited**

**U.S. PATENT DOCUMENTS**

D235,754 S \* 7/1975 Barry ..... D12/302

D325,721 S \* 4/1992 Ollier et al. .... D12/314

5,452,676 A \* 9/1995 Fiore ..... 114/291

\* cited by examiner

*Primary Examiner*—Holly Baynham  
*(74) Attorney, Agent, or Firm*—Gifford, Krass, Groh, Sprinkle, Anderson & Citkowski, P.C.

(57) **CLAIM**

The ornamental design of a racing boat, as shown and described.

**DESCRIPTION**

FIG. 1 is a perspective view of the racing boat incorporating my design;

FIG. 2 is a side elevation of the design with the other side being a mirror image;

FIG. 3 is a top plan view;

FIG. 4 is a bottom plan view;

FIG. 5 is a front elevation; and,

FIG. 6 is a rear elevation.

**1 Claim, 3 Drawing Sheets**

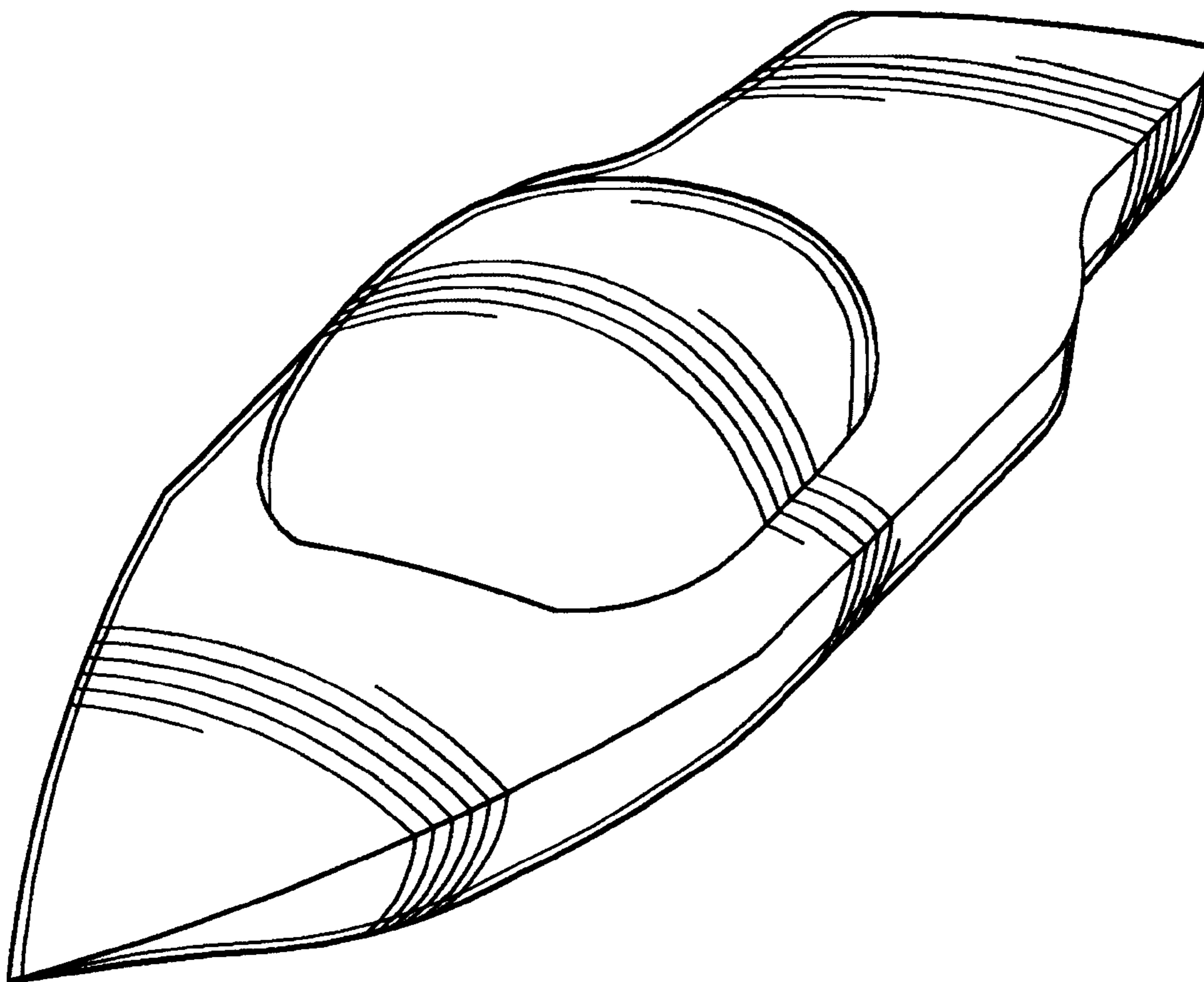

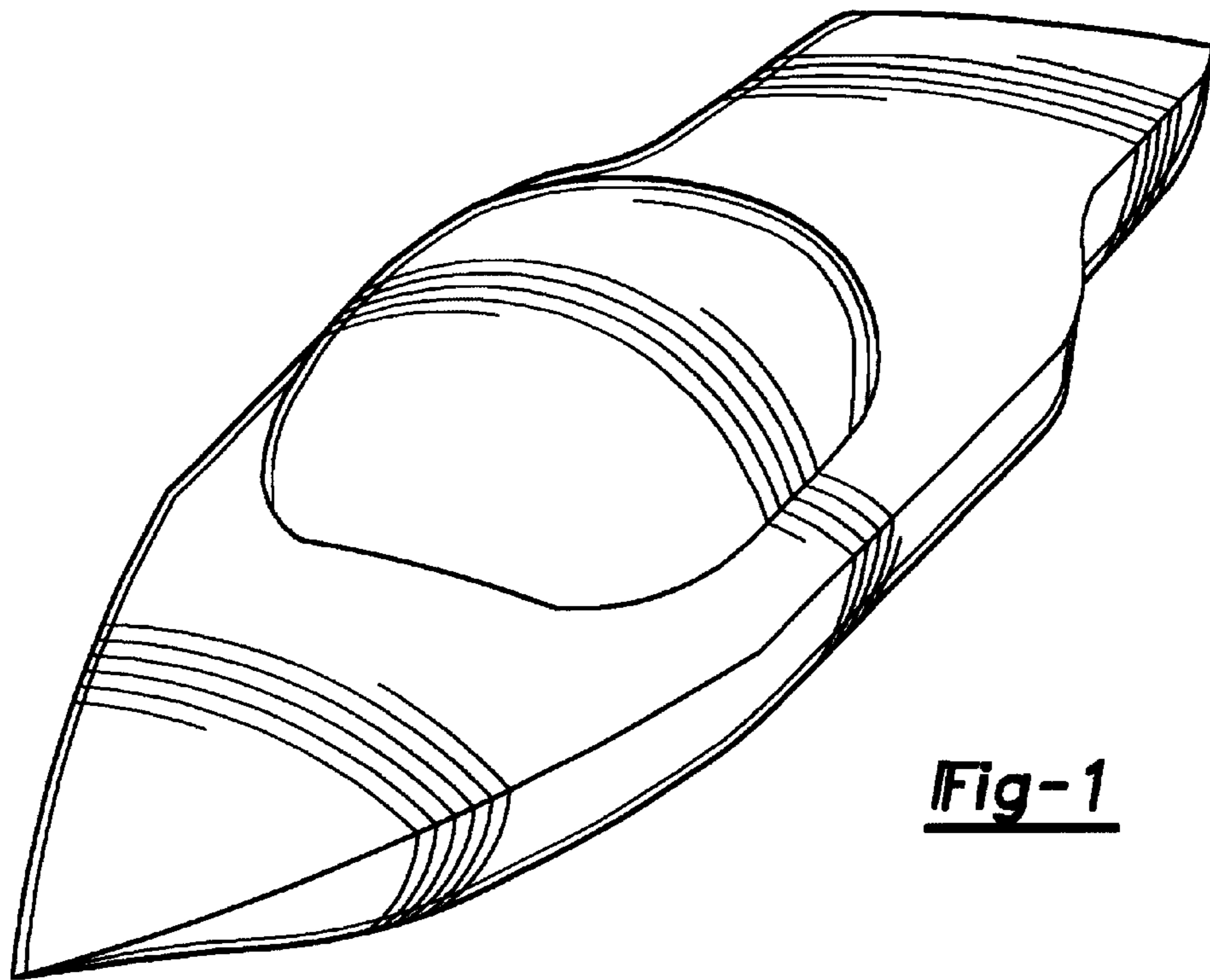

Fig-1

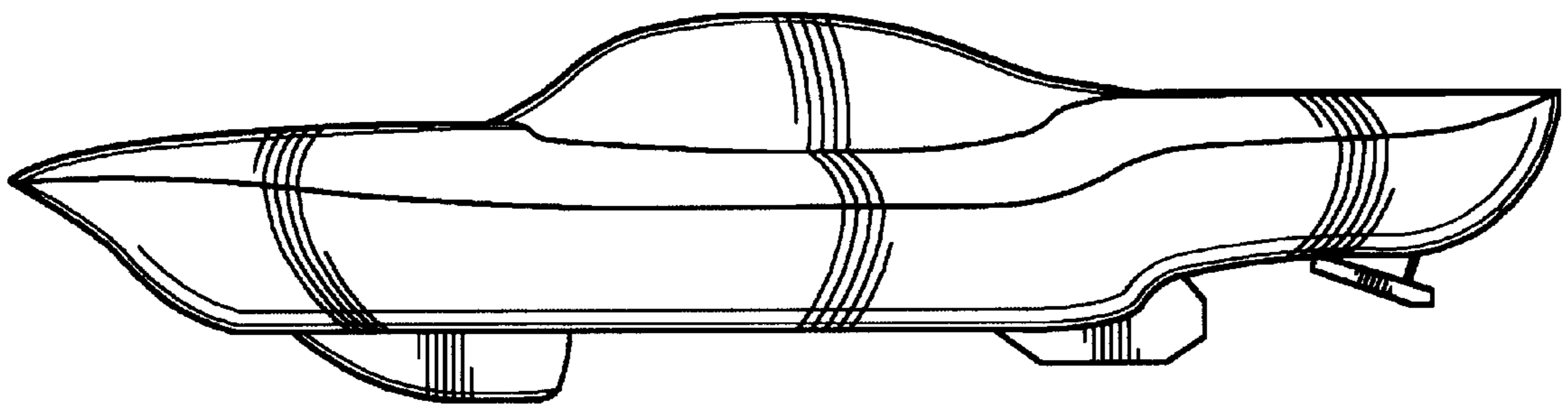

Fig-2

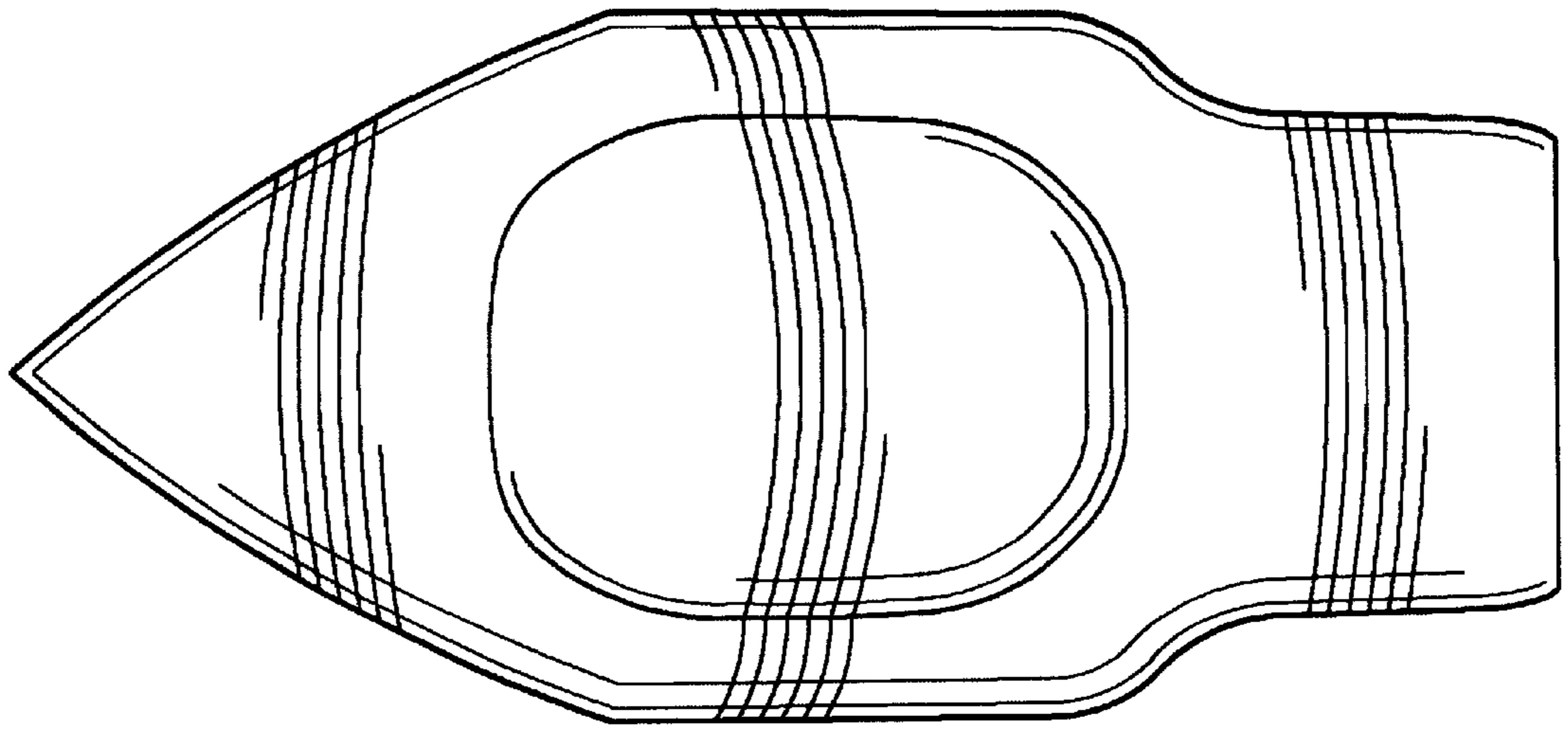

Fig-3

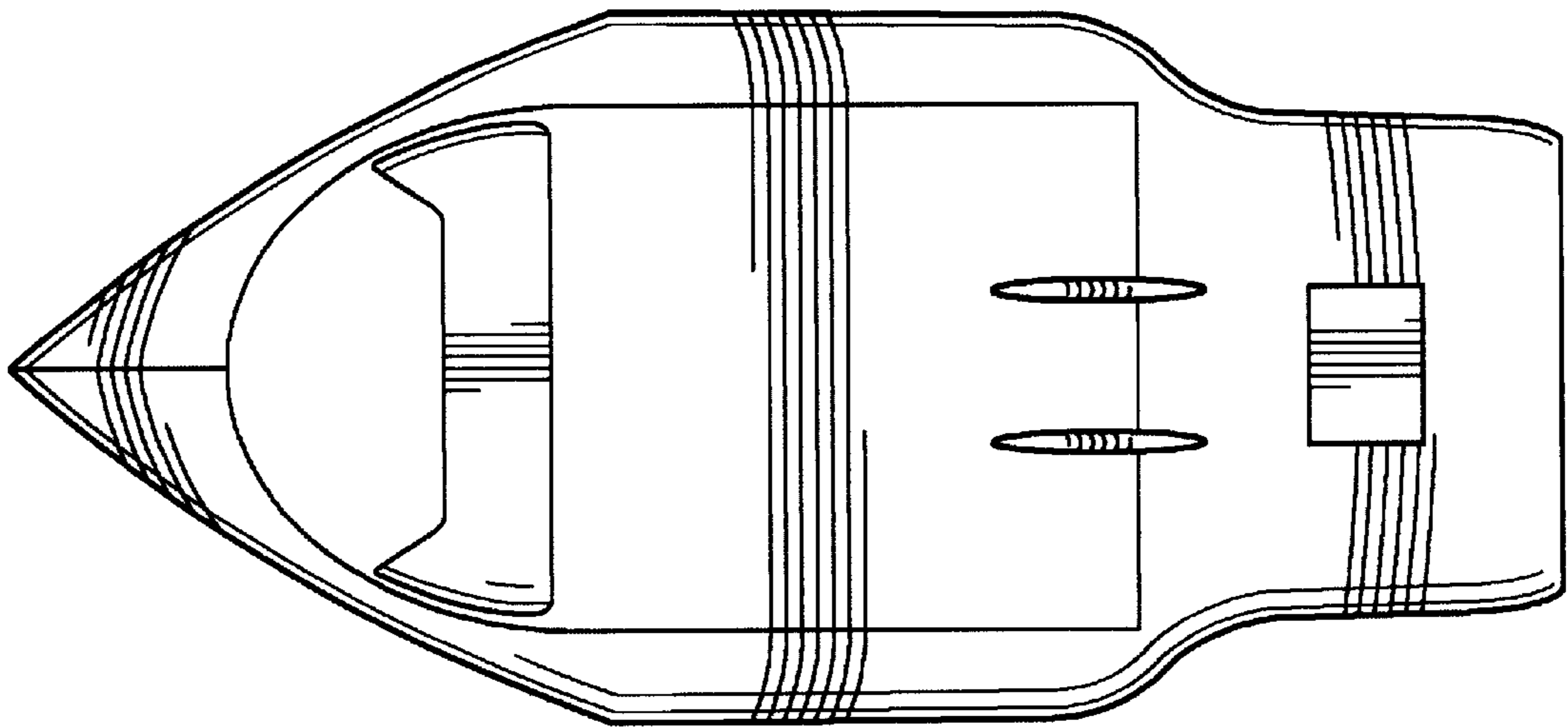

Fig-4

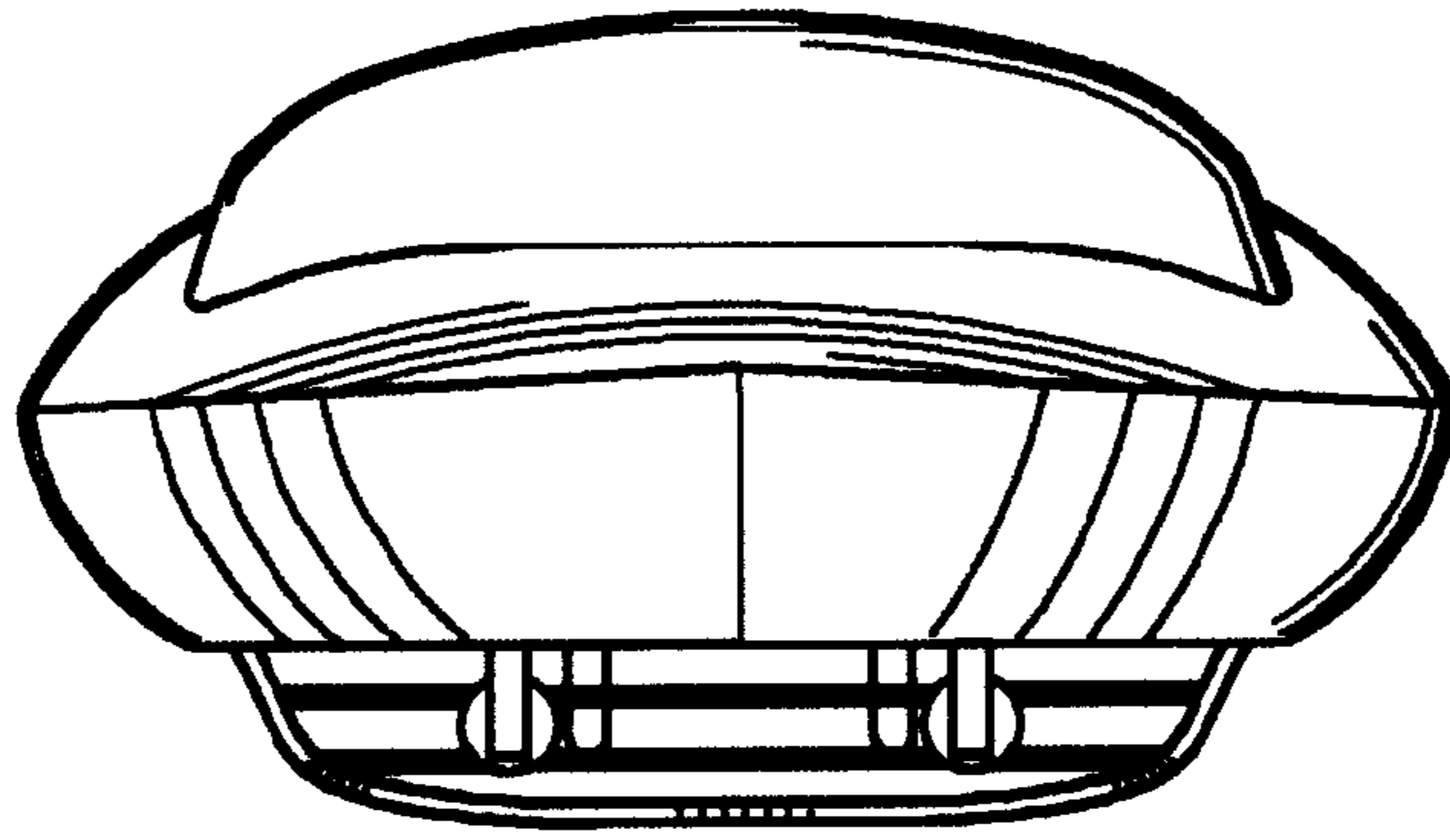

Fig-5

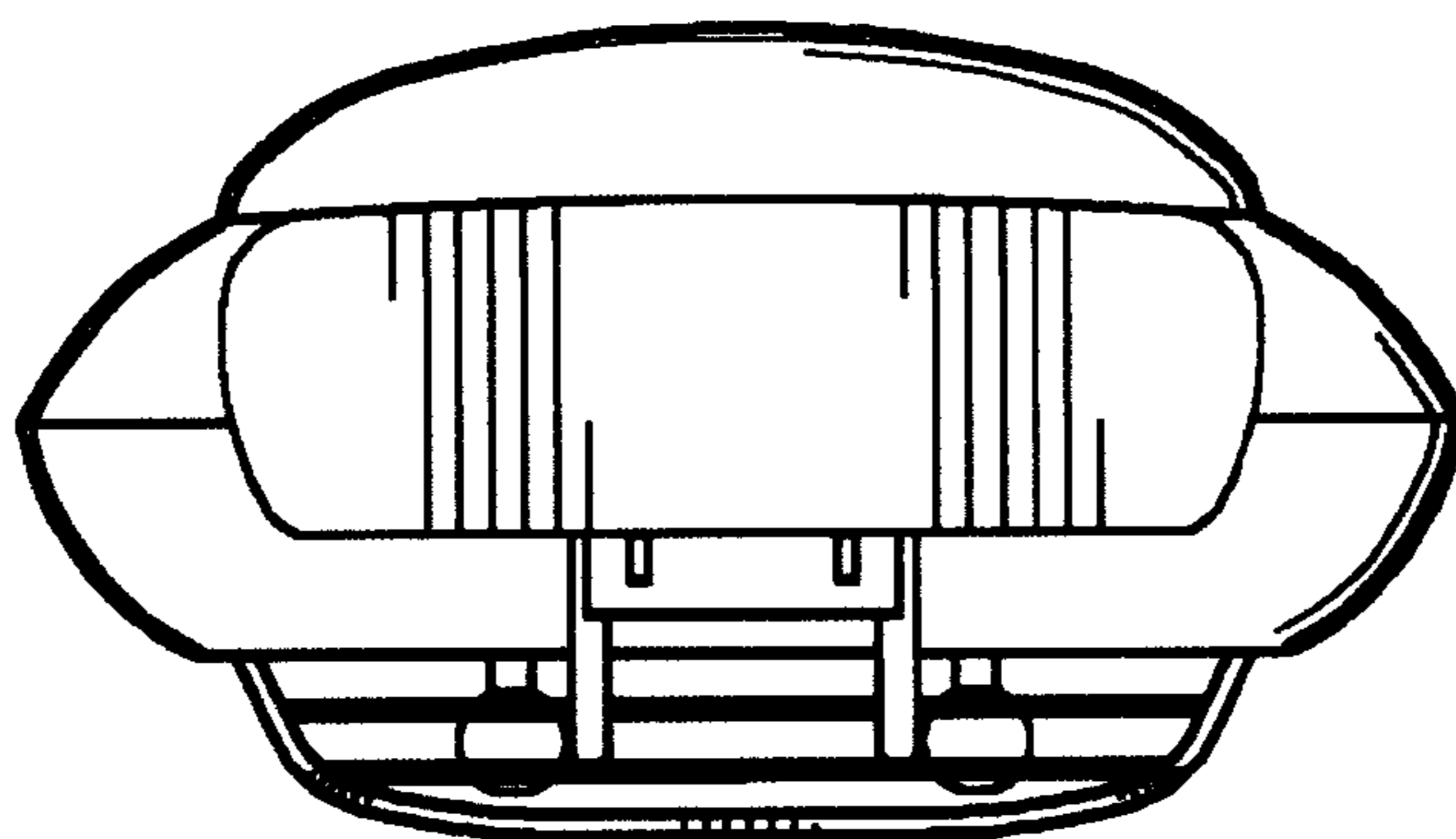

Fig-6