



US00D475569S

(12) **United States Design Patent**  
**Nichols**

(10) **Patent No.:** **US D475,569 S**

(45) **Date of Patent:** **\*\* Jun. 10, 2003**

(54) **COMBINED GAS COOKING RANGE AND GRIDDLE**

5,372,121 A 12/1994 Castillo et al.  
D430,451 S \* 9/2000 Bordet ..... D7/340

(75) Inventor: **Dan Nichols**, Huntington Beach, CA (US)

**FOREIGN PATENT DOCUMENTS**

FR 2614677 11/1988

(73) Assignee: **Dynamic Cooking Systems, Inc.**, Huntington Beach, CA (US)

**OTHER PUBLICATIONS**

Frigidaire Electric and Gas Ranges Catalog, copyright Mar. 1999. Frigidaire Self-Cleaning Electric Range.\*  
Thermador "Create" Catalog, copyright 1999. p. 13, 48" Gas Surface/Electric Range, bottom left.\*

(\*\*) Term: **14 Years**

\* cited by examiner

(21) Appl. No.: **29/154,220**

(22) Filed: **Jan. 17, 2002**

(51) **LOC (7) Cl.** ..... **70-02**

*Primary Examiner*—Sandra L. Morris

(52) **U.S. Cl.** ..... **D7/340**

(74) *Attorney, Agent, or Firm*—Knobbe, Martens, Olson & Bear, LLP

(58) **Field of Search** ..... D7/339, 340, 346, D7/347, 348, 349, 402, 407, 408; 126/19 R, 39 C, 273 R, 273 S, 275 R, 257 E, 273 A; 219/458, 460, 464, 538, 552

(57) **CLAIM**

The ornamental design for a combined gas cooking range and griddle, as shown and described above.

(56) **References Cited**

**DESCRIPTION**

**U.S. PATENT DOCUMENTS**

- 1,748,742 A \* 2/1930 Thompson et al. .... 126/39 C
- D108,114 S \* 1/1938 Burrow ..... D7/340
- 2,480,045 A \* 8/1949 Reeves ..... 126/19 R
- 2,973,524 A 3/1961 Daniels
- D201,938 S 8/1965 Tecton
- 3,923,037 A \* 12/1975 Donato ..... 126/39 C
- 4,971,024 A 11/1990 Albon et al.
- 5,046,477 A 9/1991 Bennett et al.
- D333,234 S \* 2/1993 Nichols ..... D7/340

FIG. 1 is a top, right perspective view of the invention illustrating a combined gas cooking range and griddle with a five burner cooktop, having burners shown in broken lines to illustrate that the burners can take a variety of shapes. FIG. 2 is a front elevational view thereof. FIG. 3 is a right side elevational view thereof, which is a mirror image of a left side view thereof; and, FIG. 4 is a back elevational view thereof.

**1 Claim, 4 Drawing Sheets**

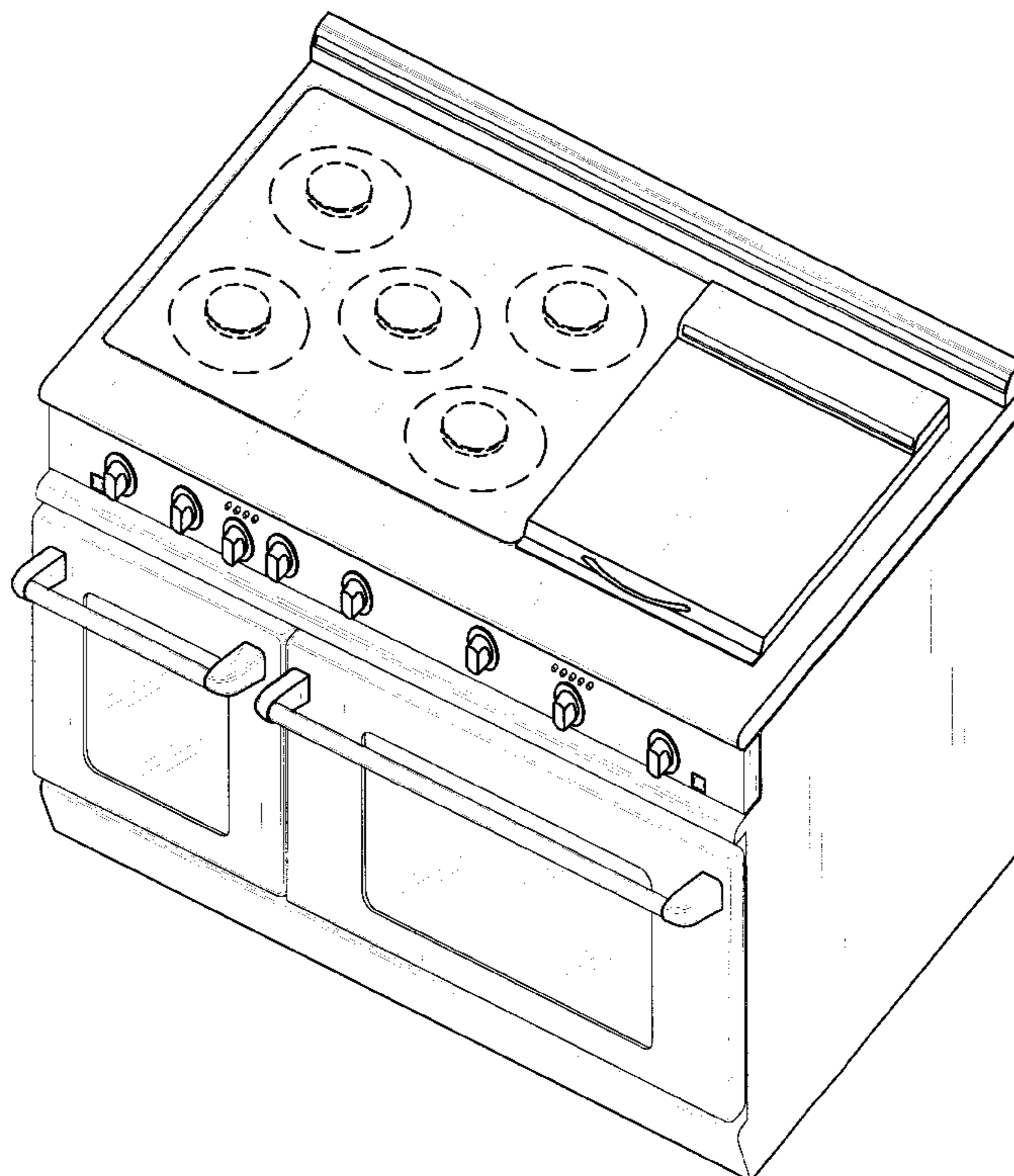

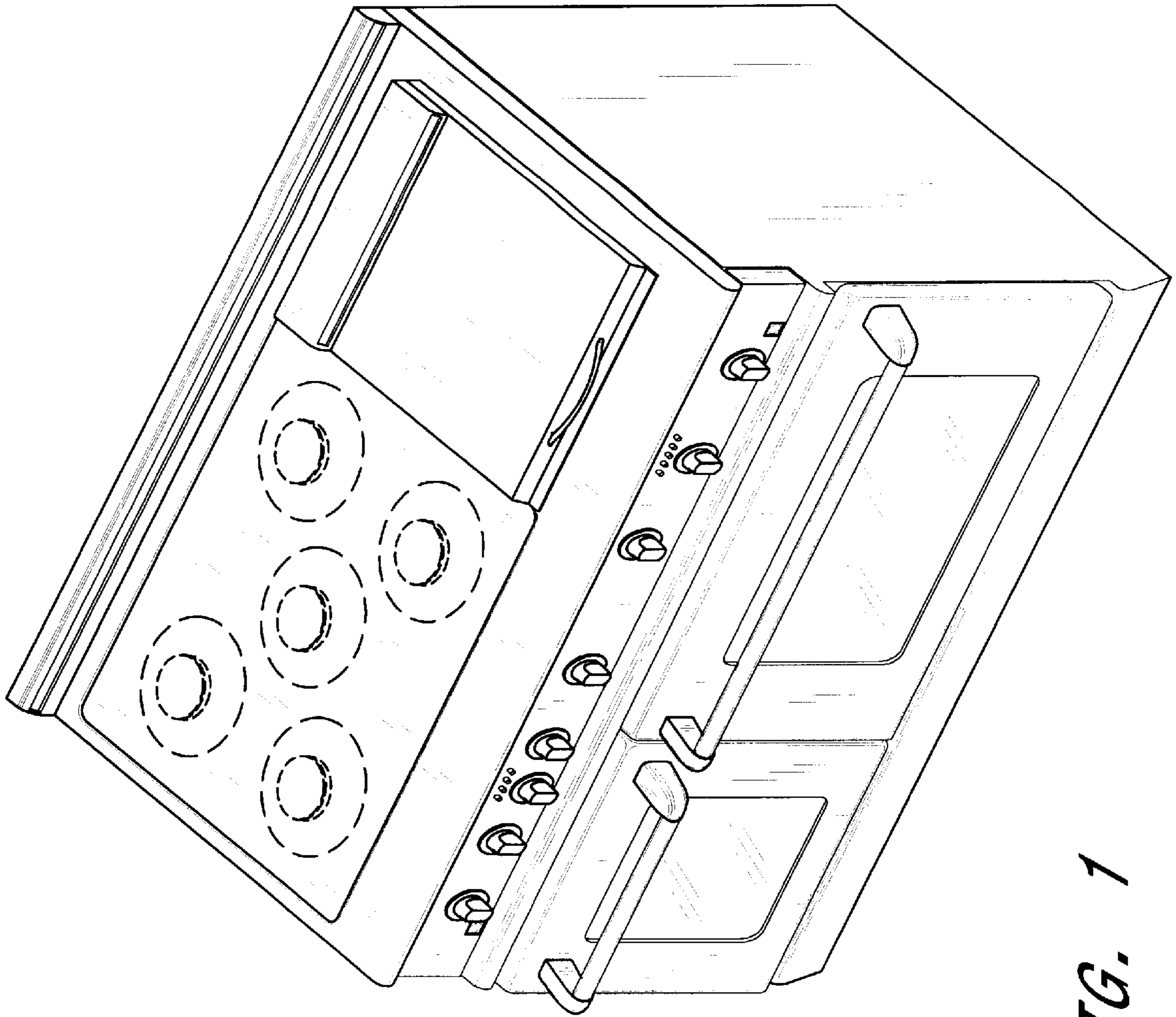
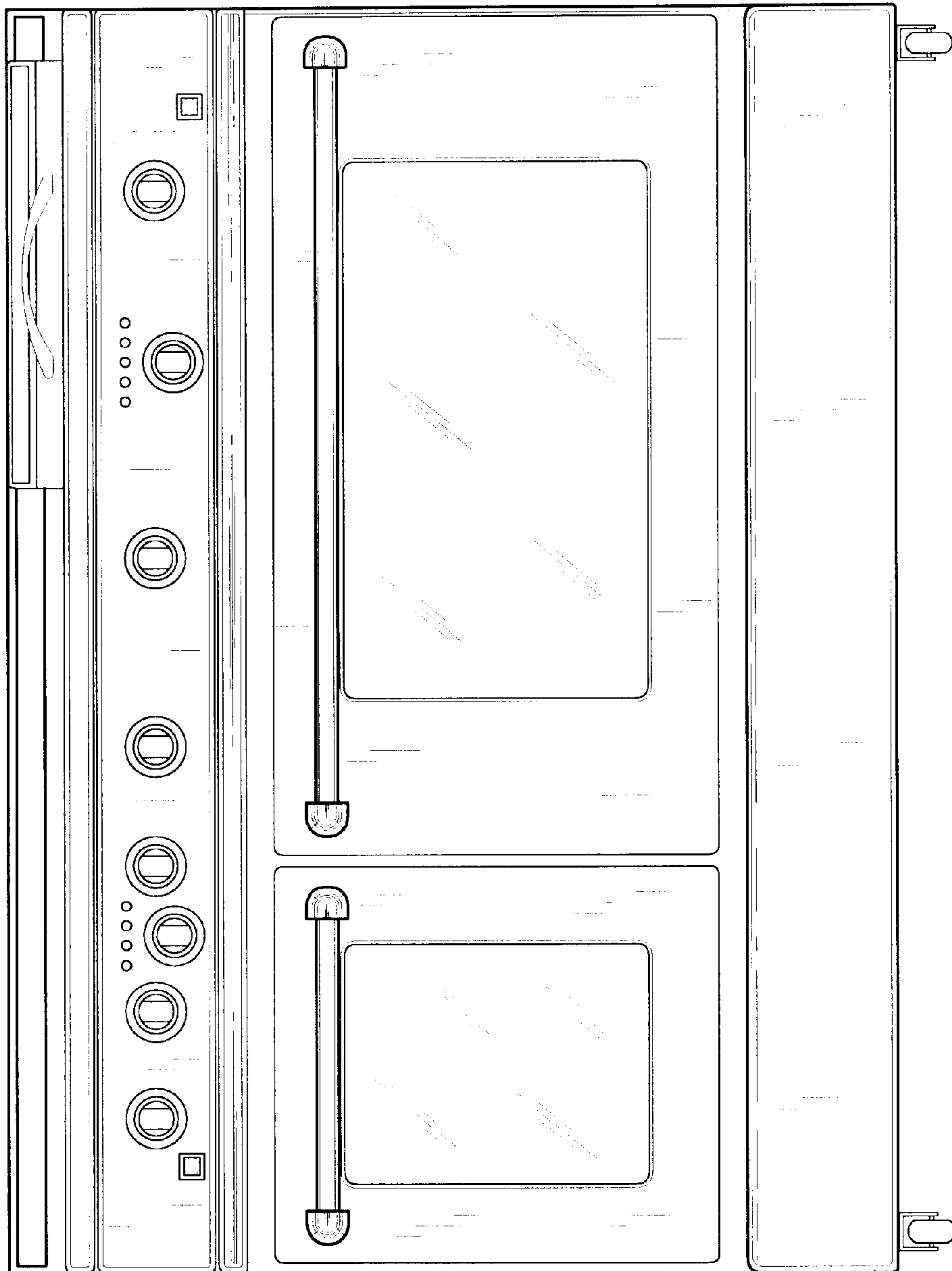
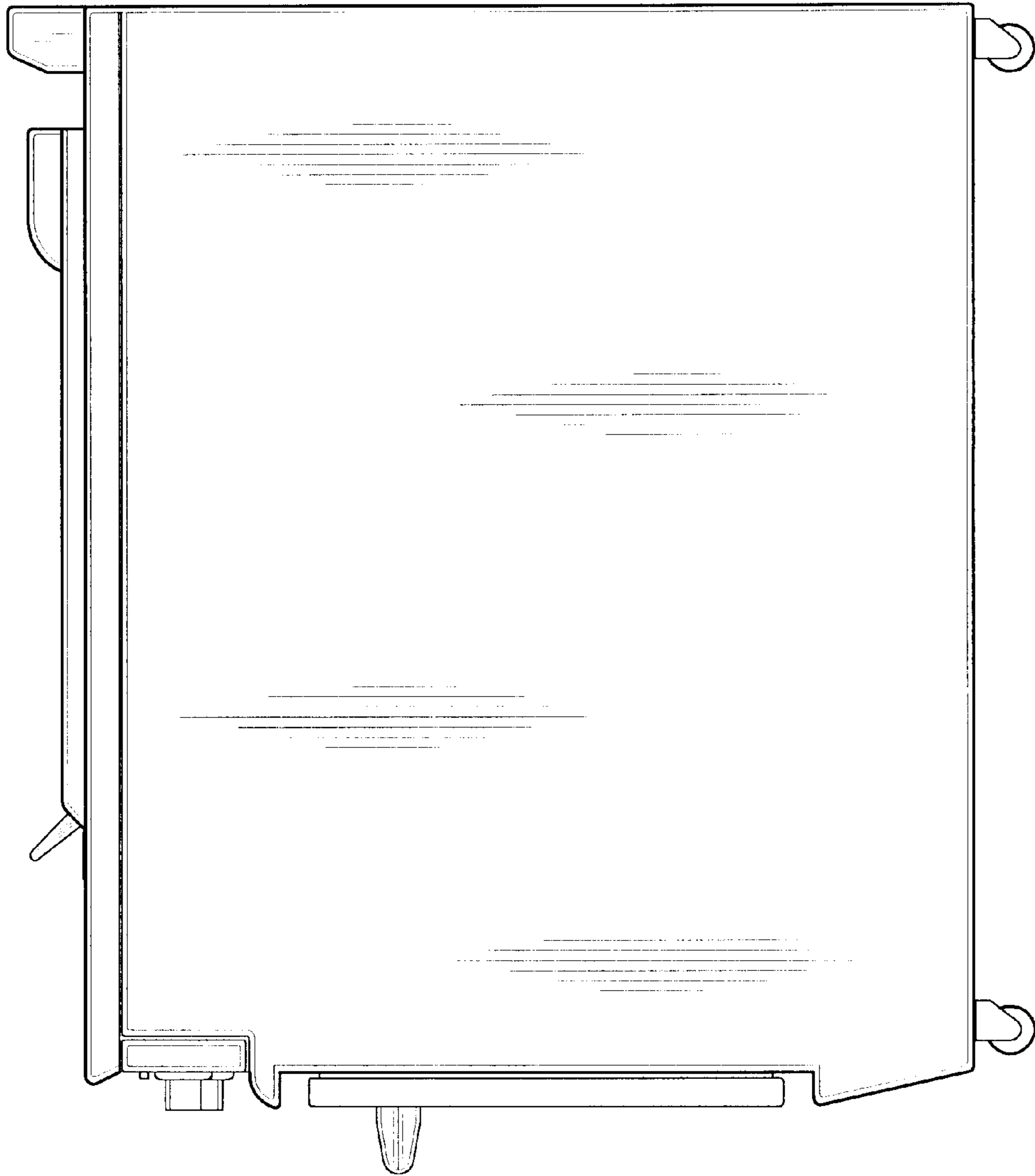

FIG. 1



*FIG. 2*



*FIG. 3*

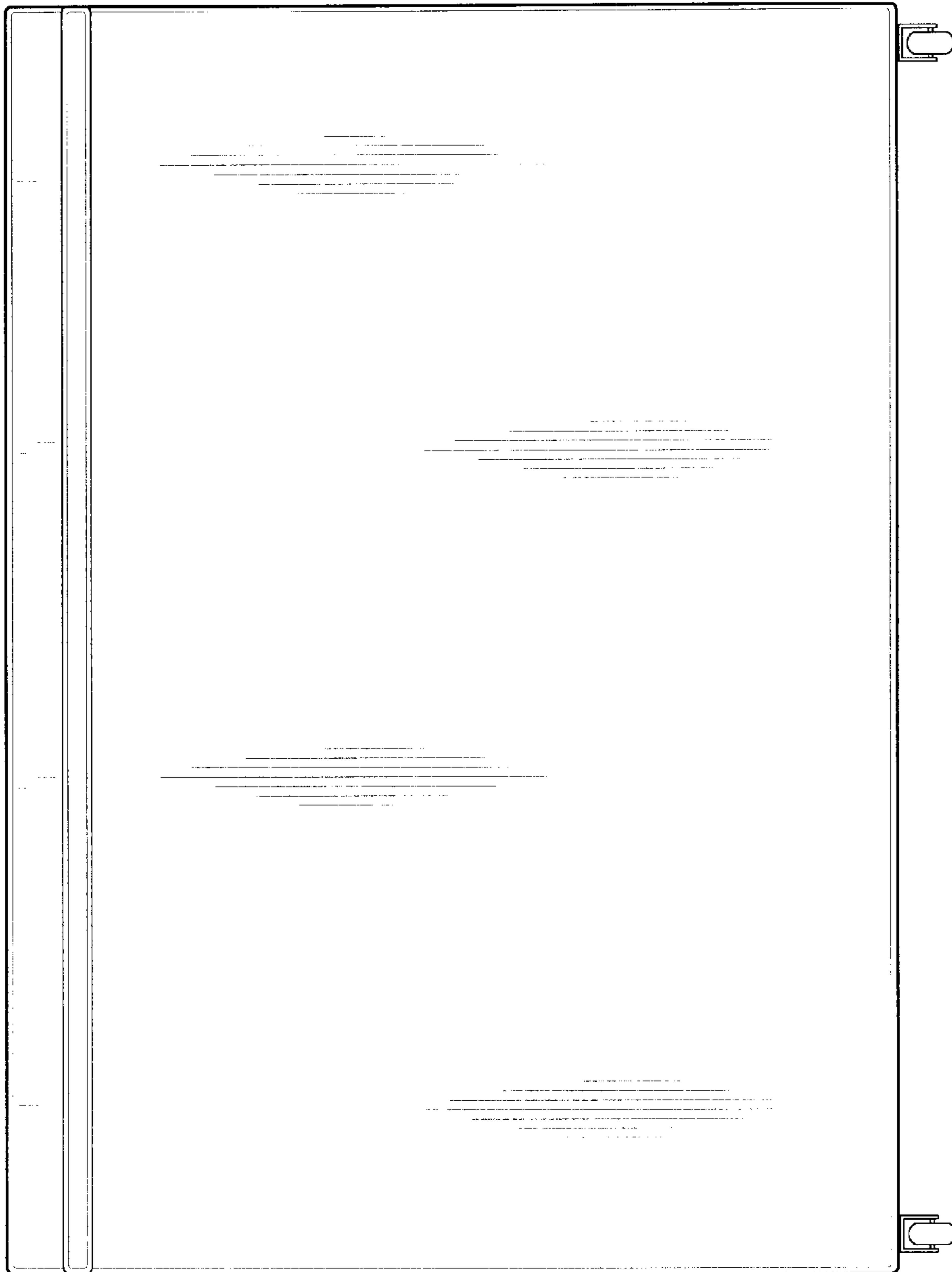

*FIG. 4*