



US00D475535S

(12) **United States Design Patent**  
**Vaes**

(10) **Patent No.:** **US D475,535 S**

(45) **Date of Patent:** **\*\* Jun. 10, 2003**

(54) **PAINT BRUSH**

(76) **Inventor:** **Ed Vaes**, 223 Avondale St. Hamilton,  
Ontario (CA), L8L 7C4

(\*\*) **Term:** **14 Years**

(21) **Appl. No.:** **29/150,740**

(22) **Filed:** **Nov. 30, 2001**

(30) **Foreign Application Priority Data**

Jun. 5, 2001 (CA) ..... 2001-1399

(51) **LOC (7) Cl.** ..... **04-04**

(52) **U.S. Cl.** ..... **D4/132**

(58) **Field of Search** ..... D4/132, 135, 138;  
15/143.1, 159.1, 160, 168, 171, 175, 176.1,  
191.1, 192-196, 202; 16/110.1, 430

(56) **References Cited**

**U.S. PATENT DOCUMENTS**

1,468,716	A	*	9/1923	Kersting et al.	
1,826,165	A	*	10/1931	Cartwright	15/143.1
2,490,159	A	*	12/1949	Ricchiuti	15/202
2,589,779	A	*	3/1952	Cortes	15/202
2,629,125	A	*	2/1953	Ferguson	15/202
2,779,043	A	*	1/1957	McMillan	15/193
4,494,268	A	*	1/1985	Chu	15/176.1
4,598,437	A	*	7/1986	Ernest et al.	15/176.1
5,749,117	A	*	5/1998	Forsline	
D412,618	S	*	8/1999	Parker et al.	D4/122
D454,432	S	*	3/2002	Ancona et al.	D4/138
6,408,474	B1	*	6/2002	Husted et al.	15/143.1

**OTHER PUBLICATIONS**

The Painter's Advantage Ltd. © 1986, Chip Brushes, bot-  
tom, right of p. 5.\*

\* cited by examiner

*Primary Examiner*—Alan P. Douglas  
*Assistant Examiner*—Lavone D. Tabor

(57) **CLAIM**

The ornamental design for a paint brush, as shown.

**DESCRIPTION**

FIG. 1 is a top plan view of a paint brush showing my new design;  
 FIG. 2 is a side elevational view of FIG. 1;  
 FIG. 3 is a top, front perspective view of FIG. 1;  
 FIG. 4 is a bottom, rear perspective view of FIG. 1;  
 FIG. 5 is a top plan view of a second embodiment of the paint brush;  
 FIG. 6 is a side elevational view of FIG. 5;  
 FIG. 7 is a top, front perspective view of FIG. 5;  
 FIG. 8 is a bottom, rear perspective view of FIG. 5;  
 FIG. 9 is a top plan view of a third embodiment of the paint brush;  
 FIG. 10 is a side elevational view of FIG. 9;  
 FIG. 11 is a top, front perspective view of FIG. 9;  
 FIG. 12 is a bottom, rear perspective view of FIG. 9;  
 FIG. 13 is a top plan view of a fourth embodiment of the paint brush;  
 FIG. 14 is a side elevational view of FIG. 13;  
 FIG. 15 is a top, front perspective view of FIG. 13;  
 FIG. 16 is a bottom, rear perspective view of FIG. 13;  
 FIG. 17 is a top plan view of a fifth embodiment of the paint brush;  
 FIG. 18 is a side elevational view of FIG. 17;  
 FIG. 19 is a top, front perspective view of FIG. 17; and,  
 FIG. 20 is a bottom, rear perspective view of FIG. 17.

**1 Claim, 12 Drawing Sheets**

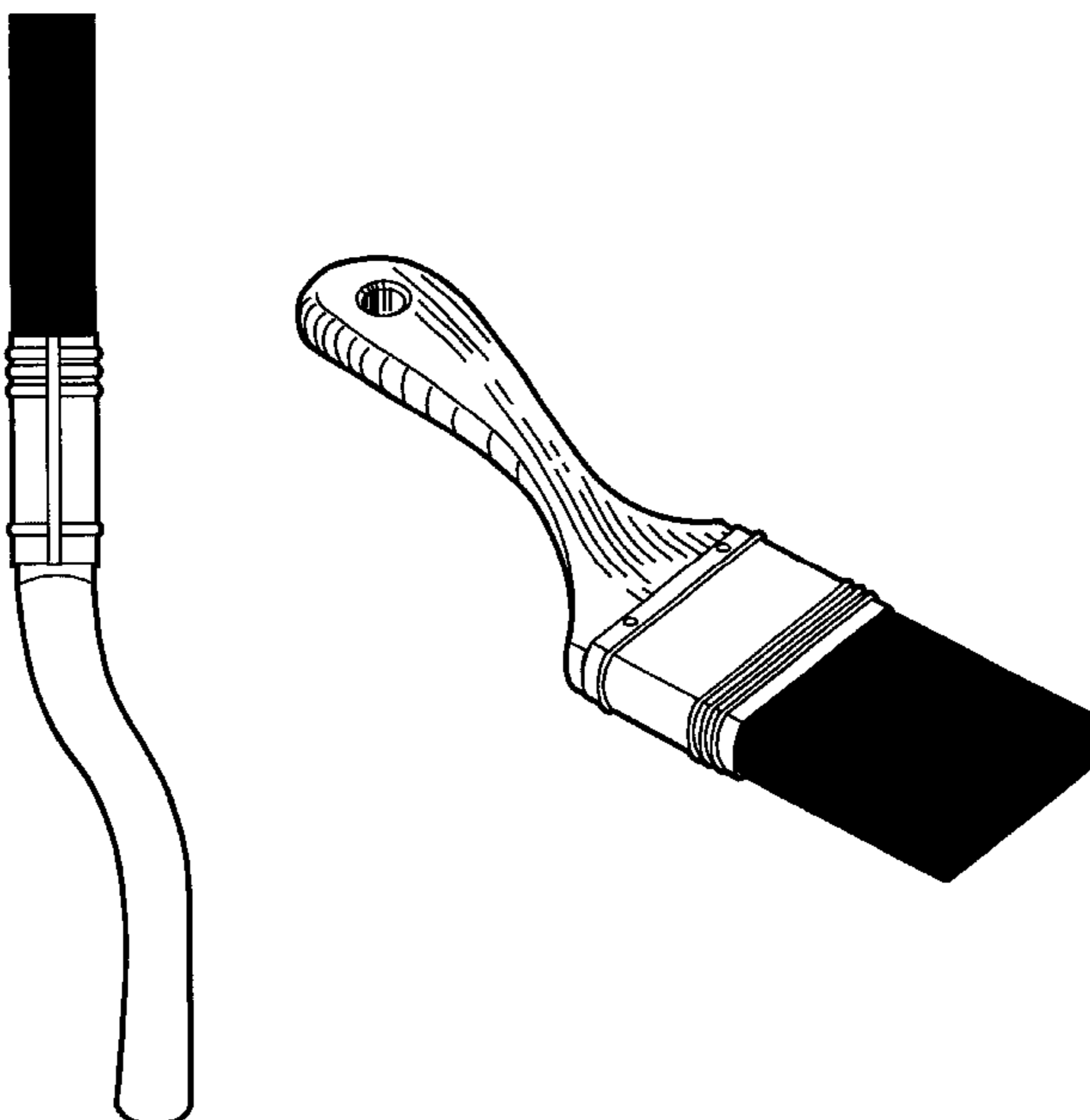

FIG. 1

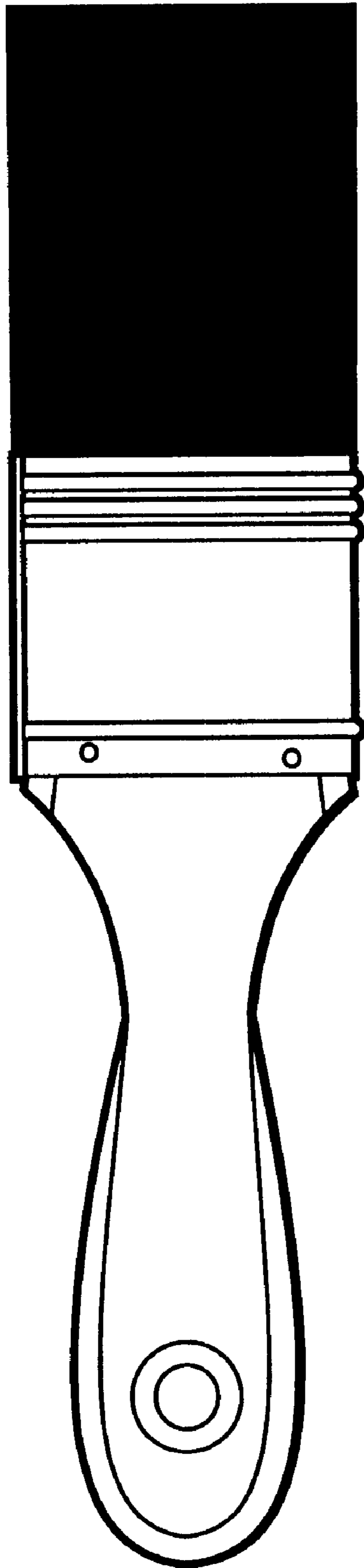
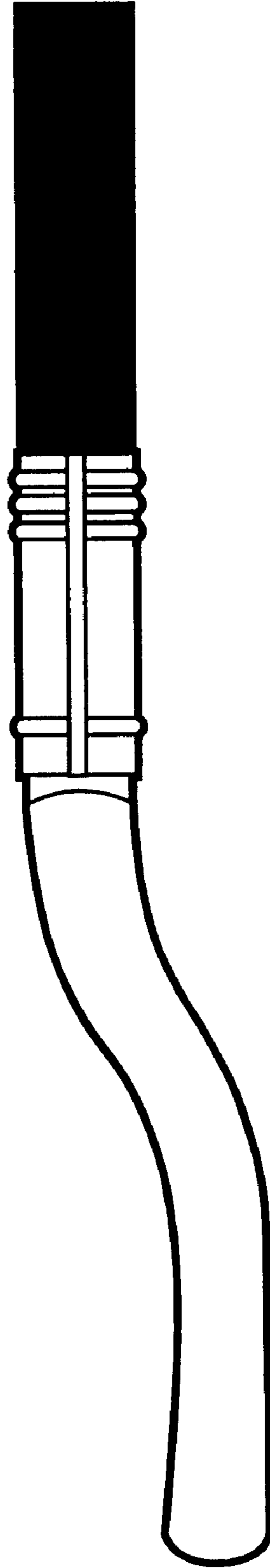

FIG. 2



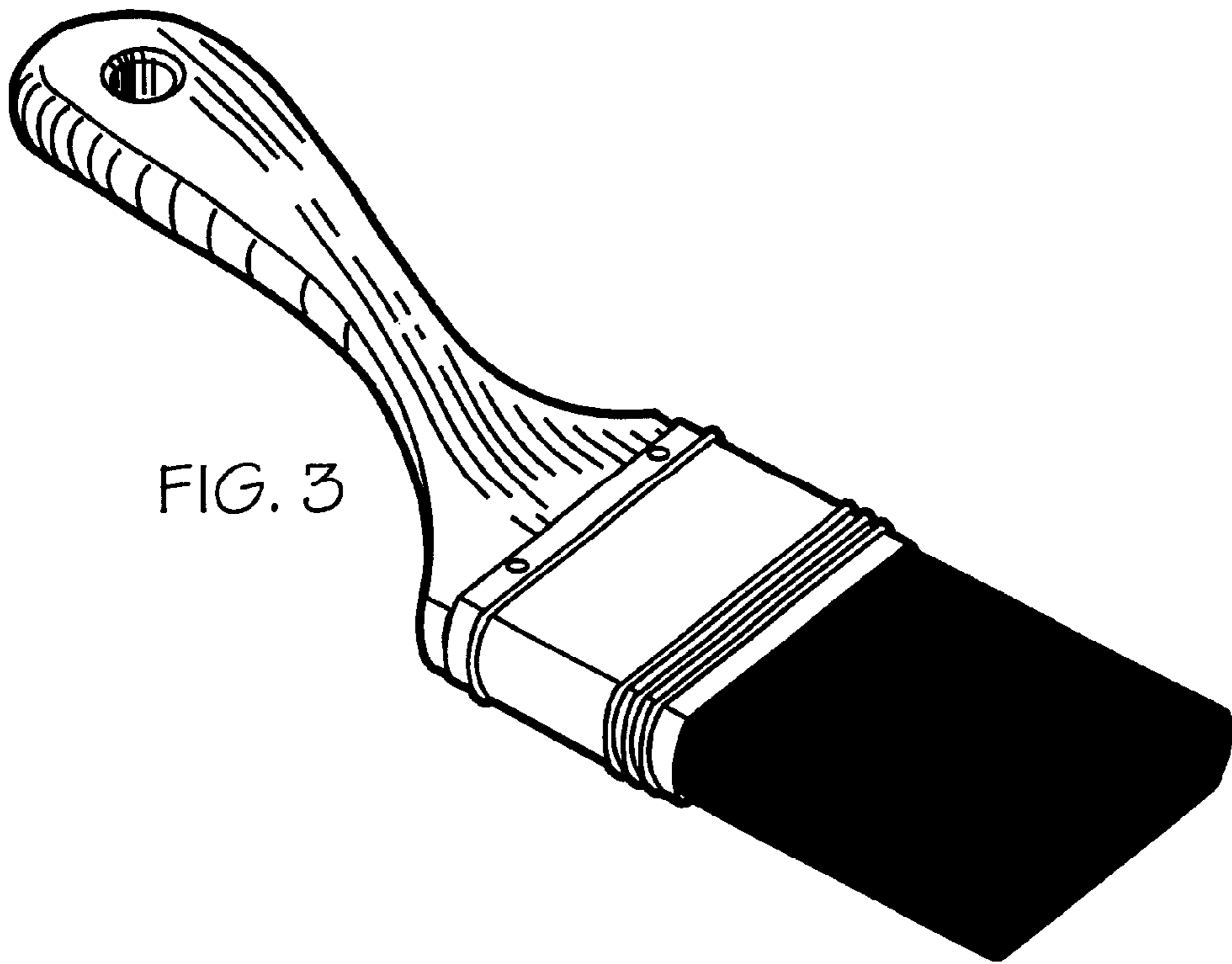

FIG. 3

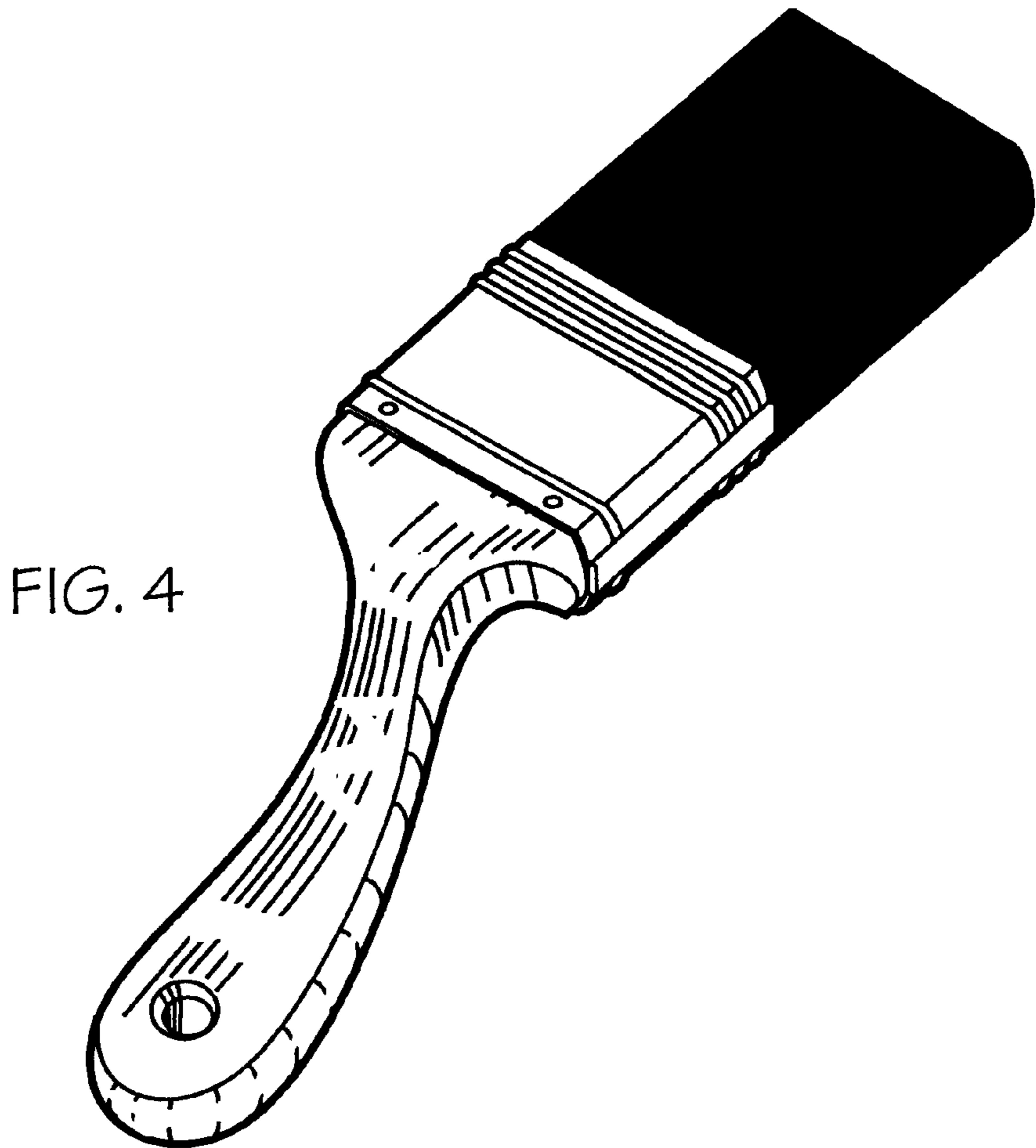

FIG. 4

FIG. 5

FIG. 6

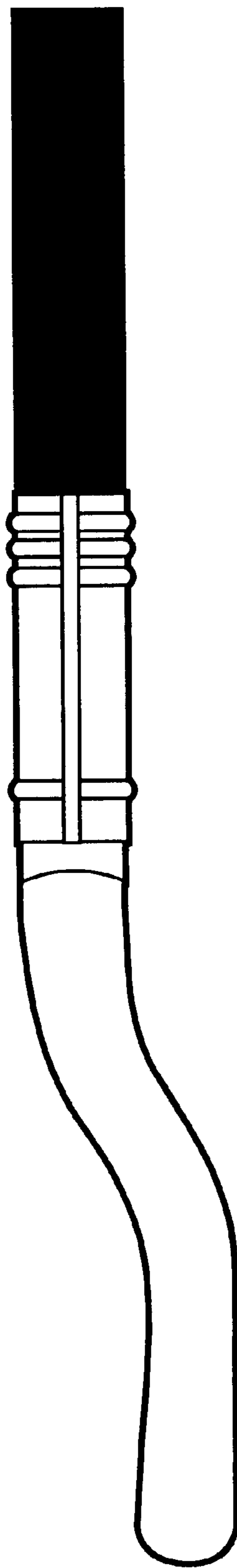
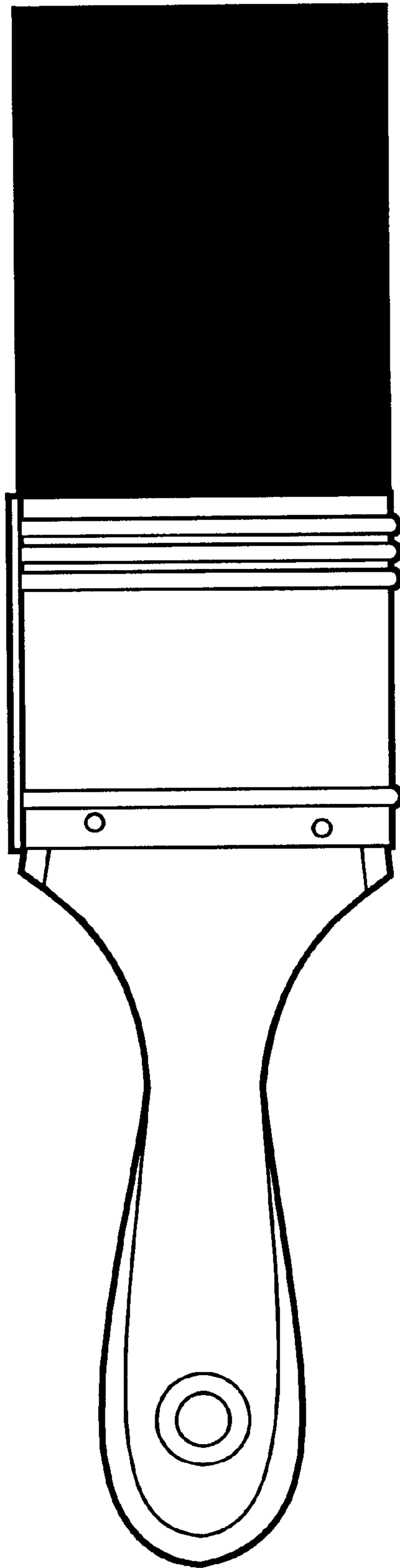

FIG. 7

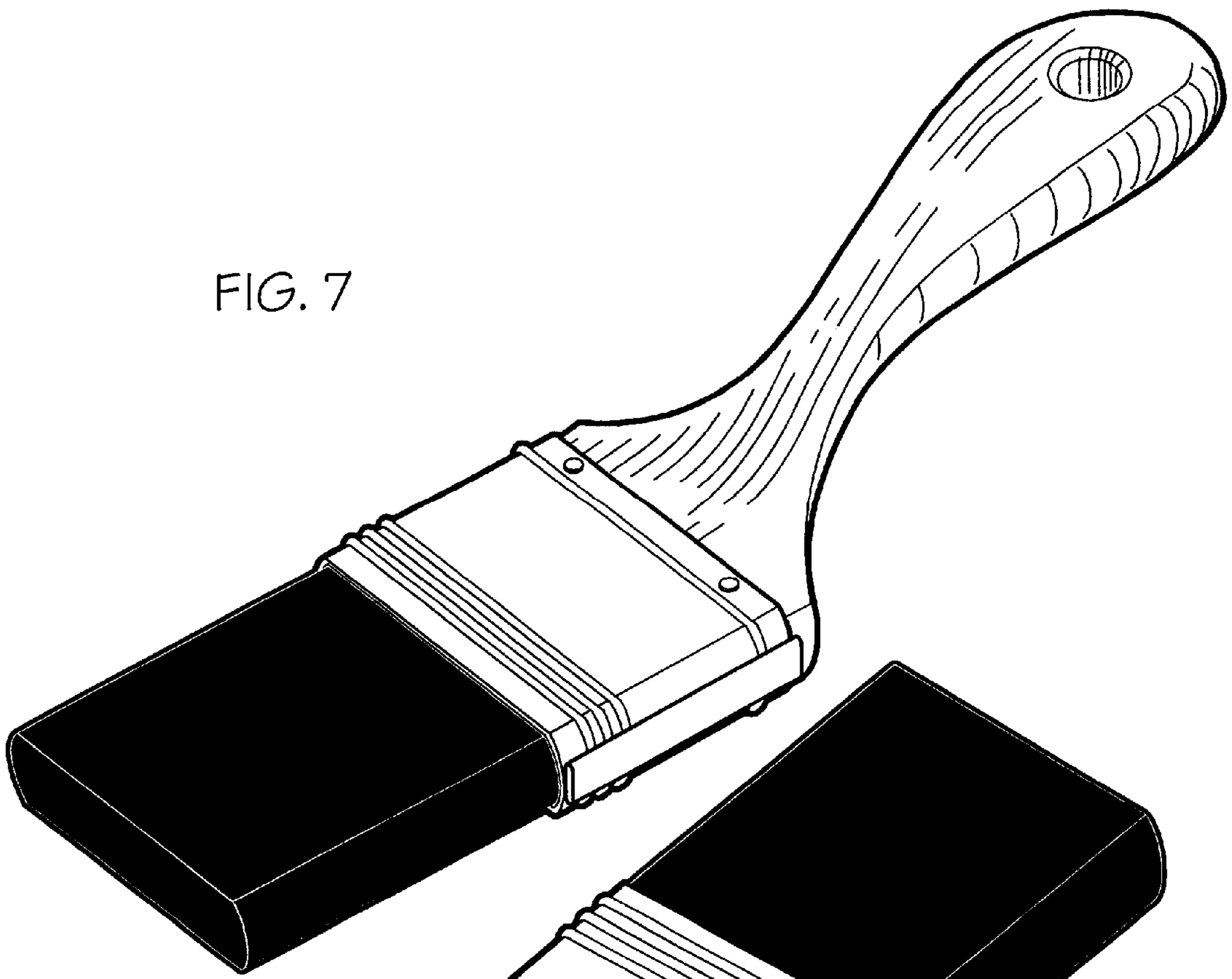

FIG. 8

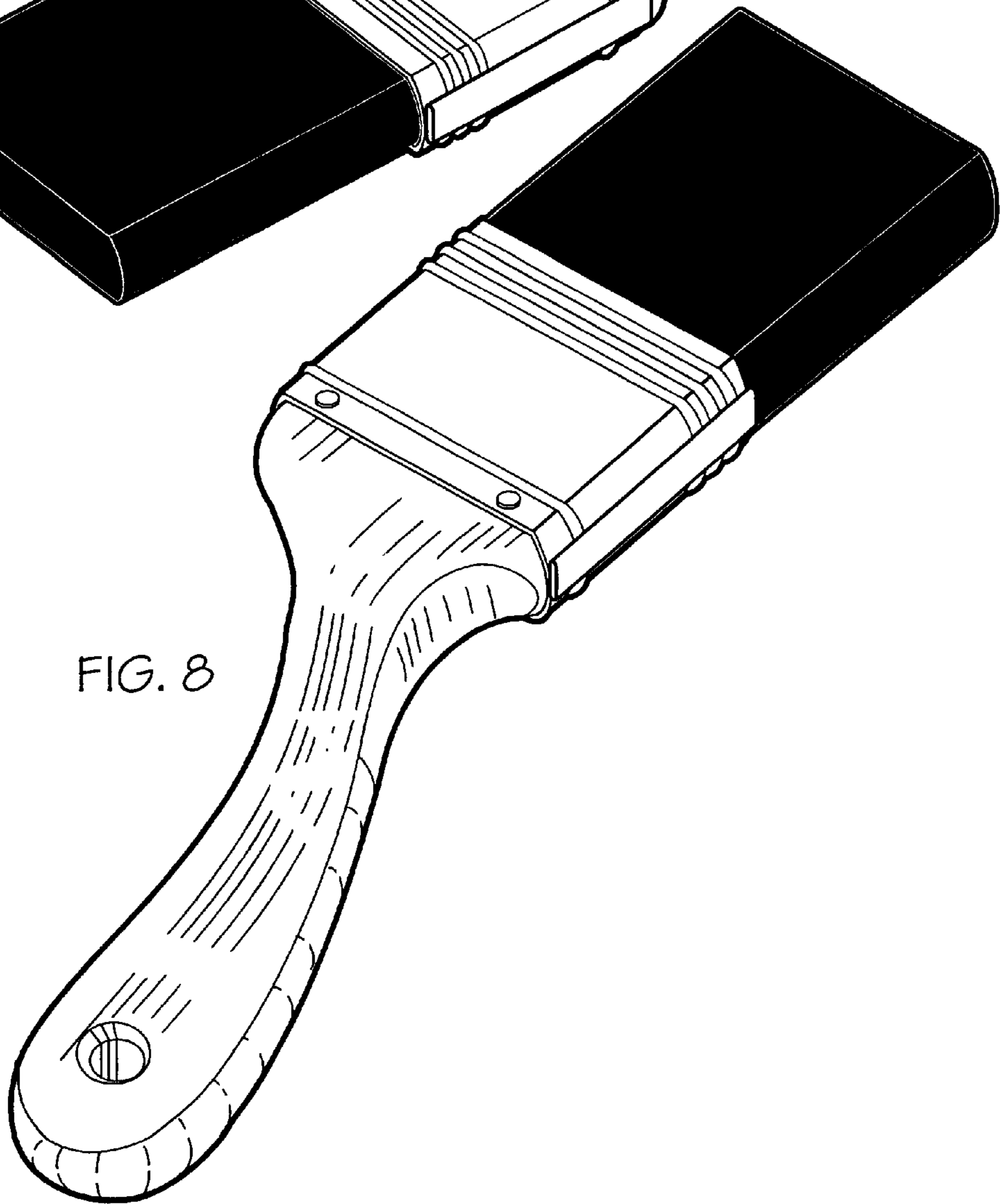

FIG. 9

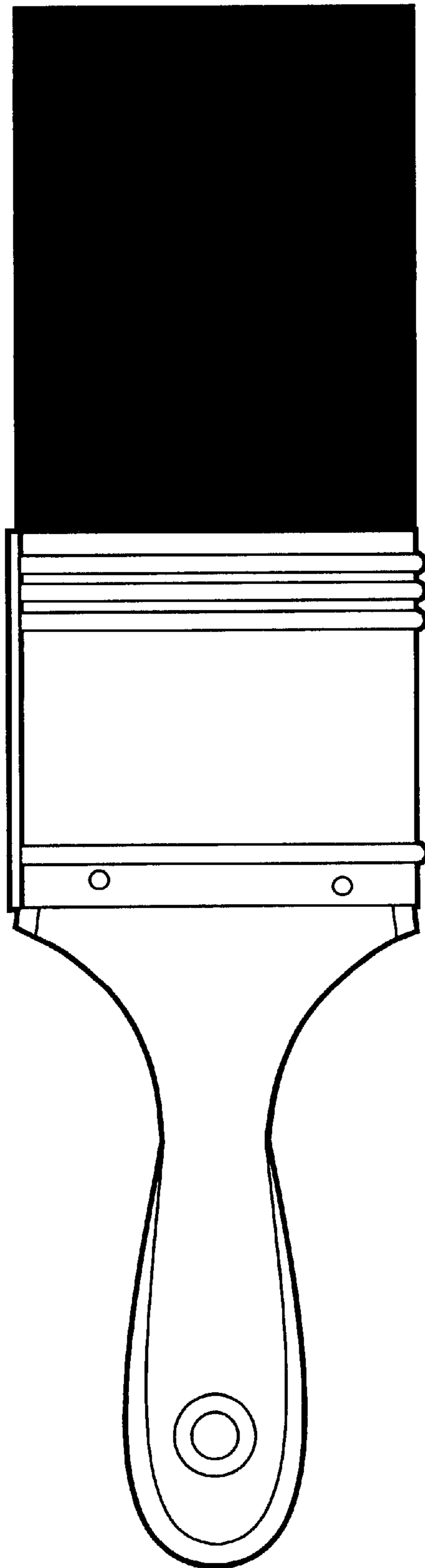
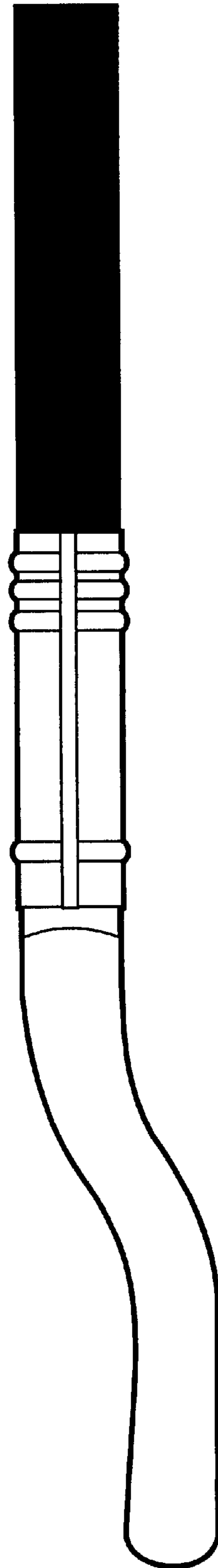

FIG. 10



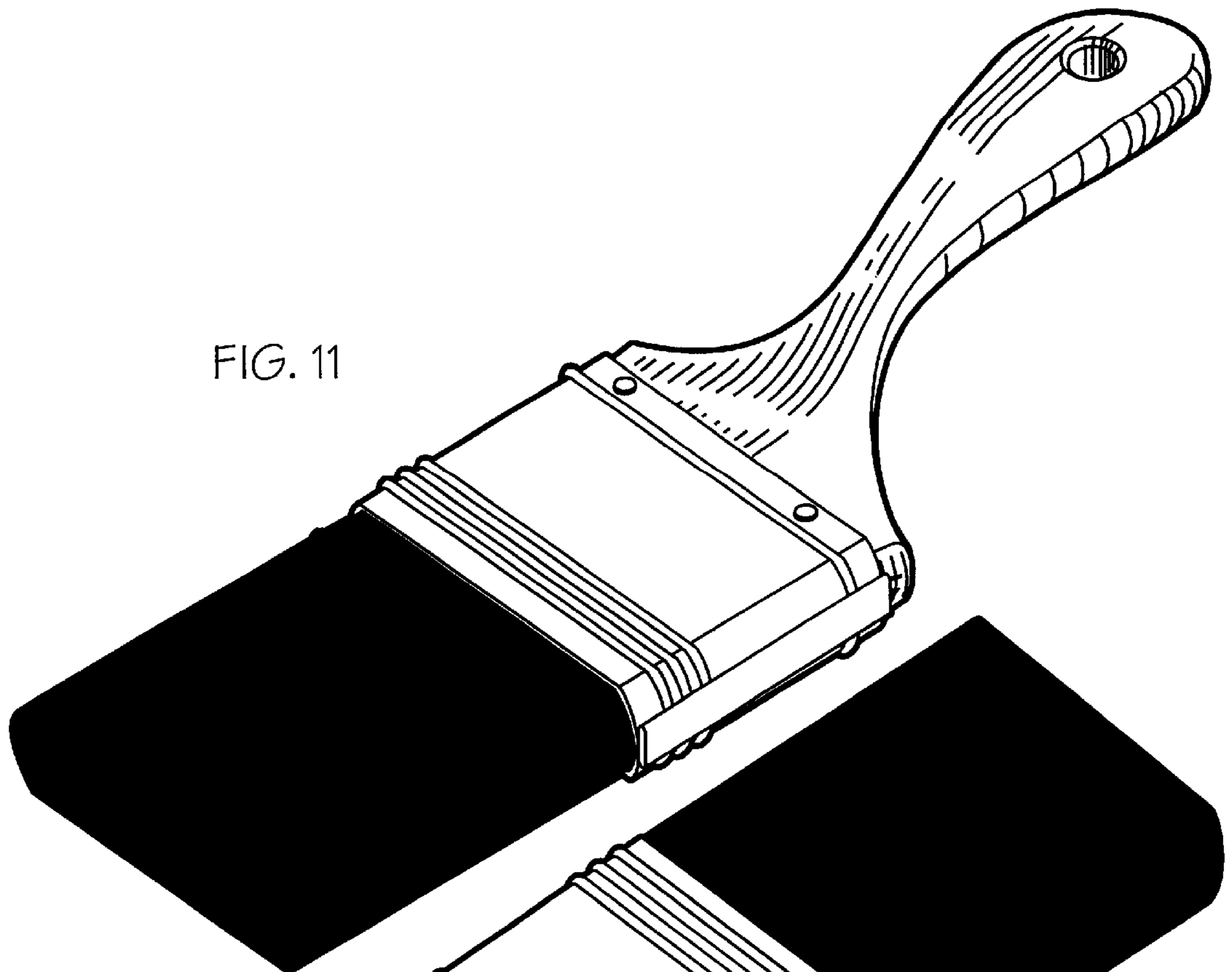

FIG. 11

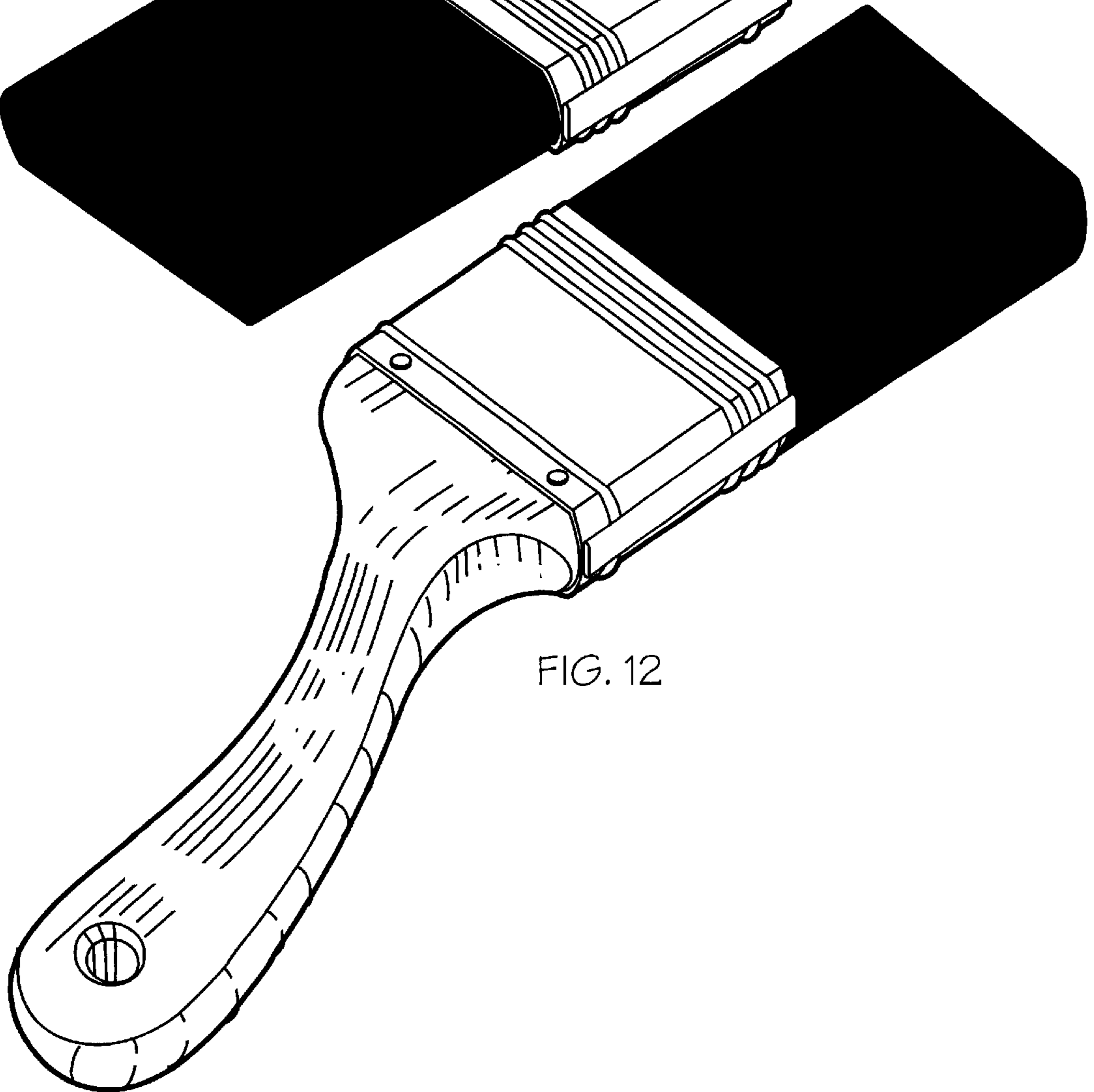

FIG. 12

FIG. 13

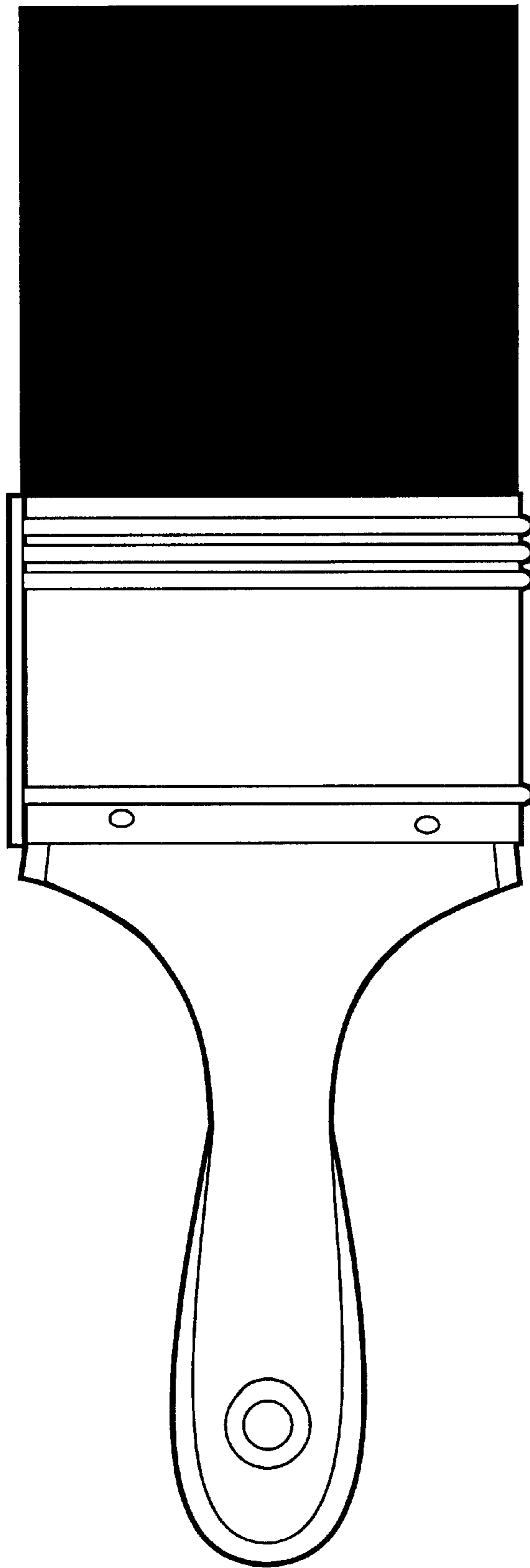

FIG. 14

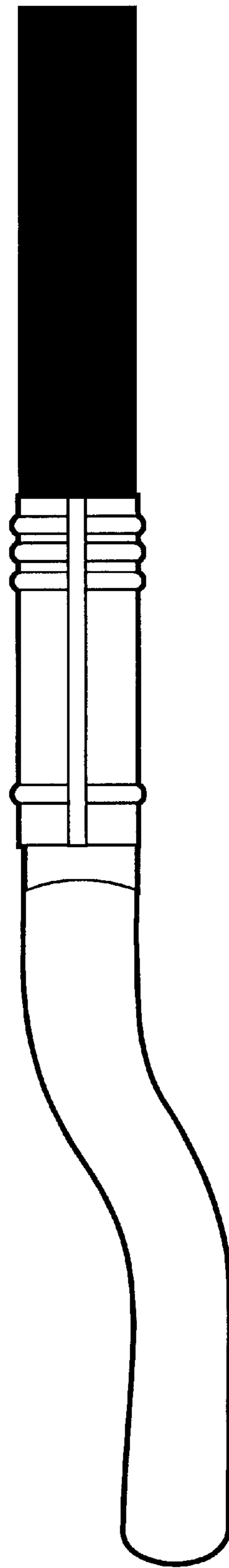
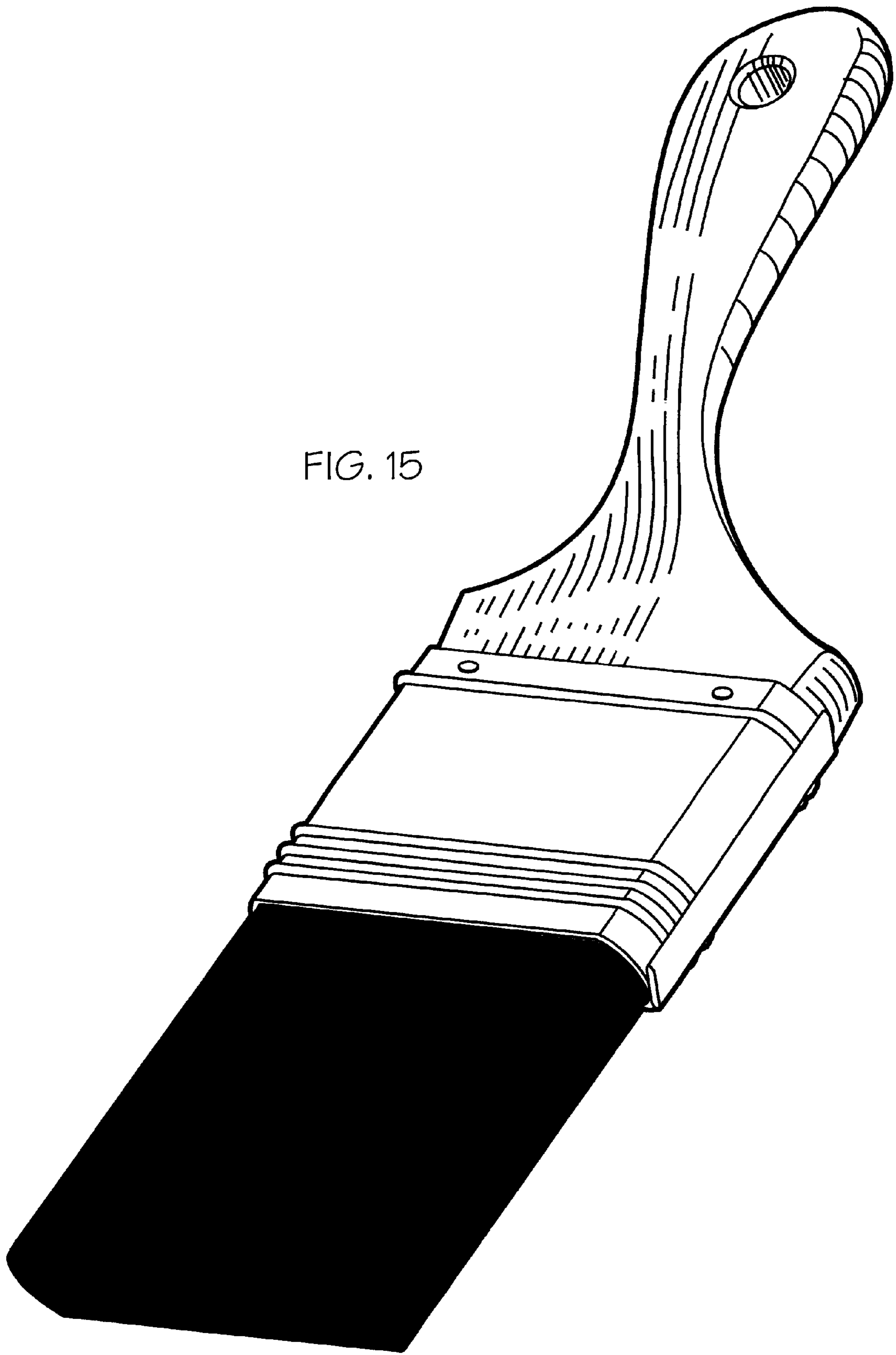



FIG. 15



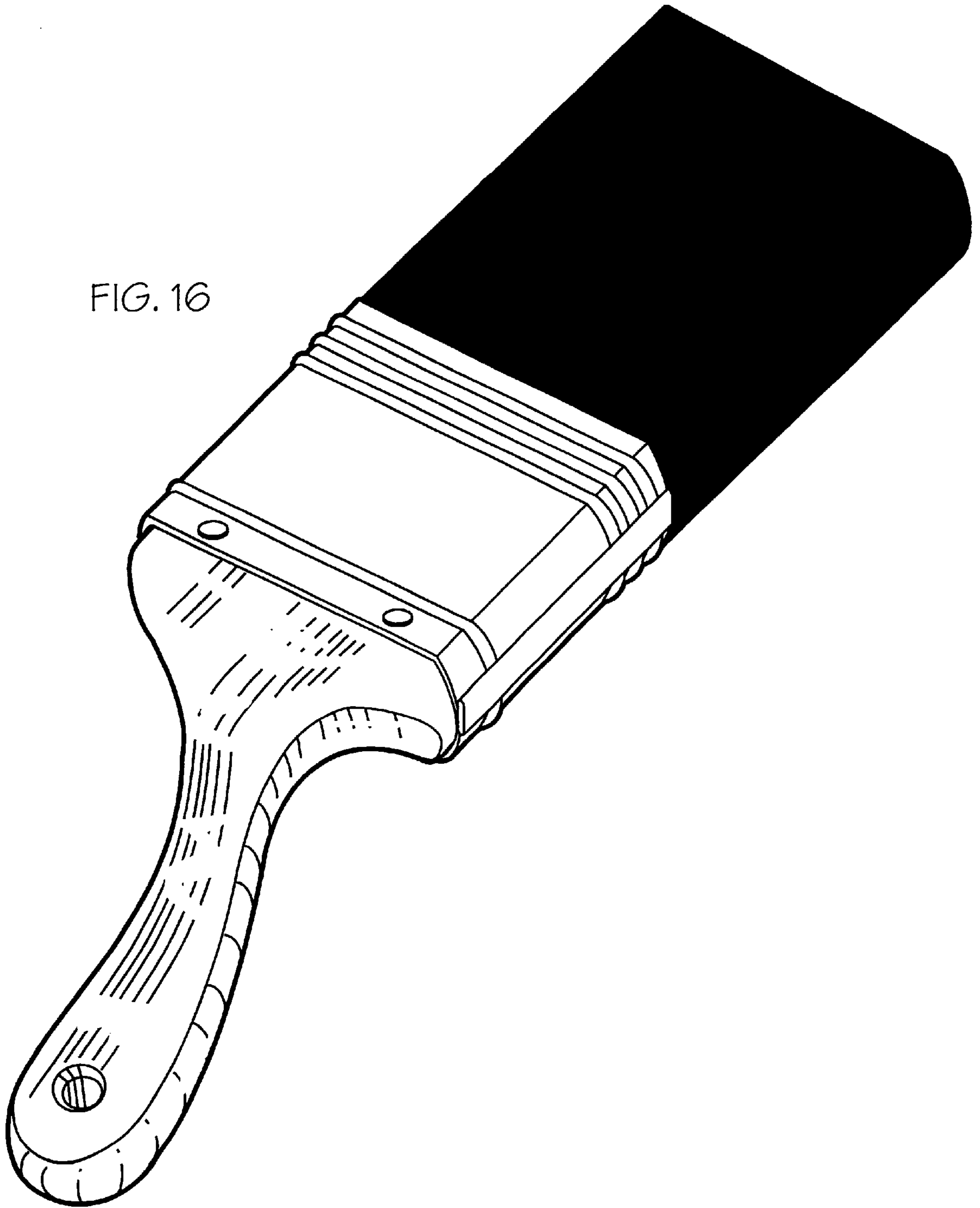

FIG. 16

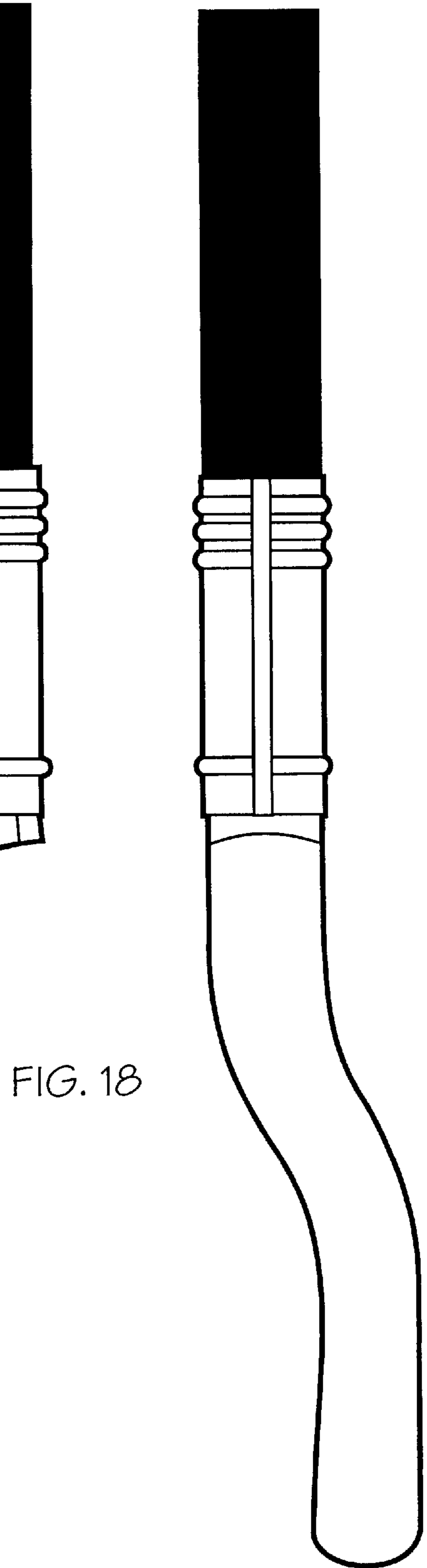
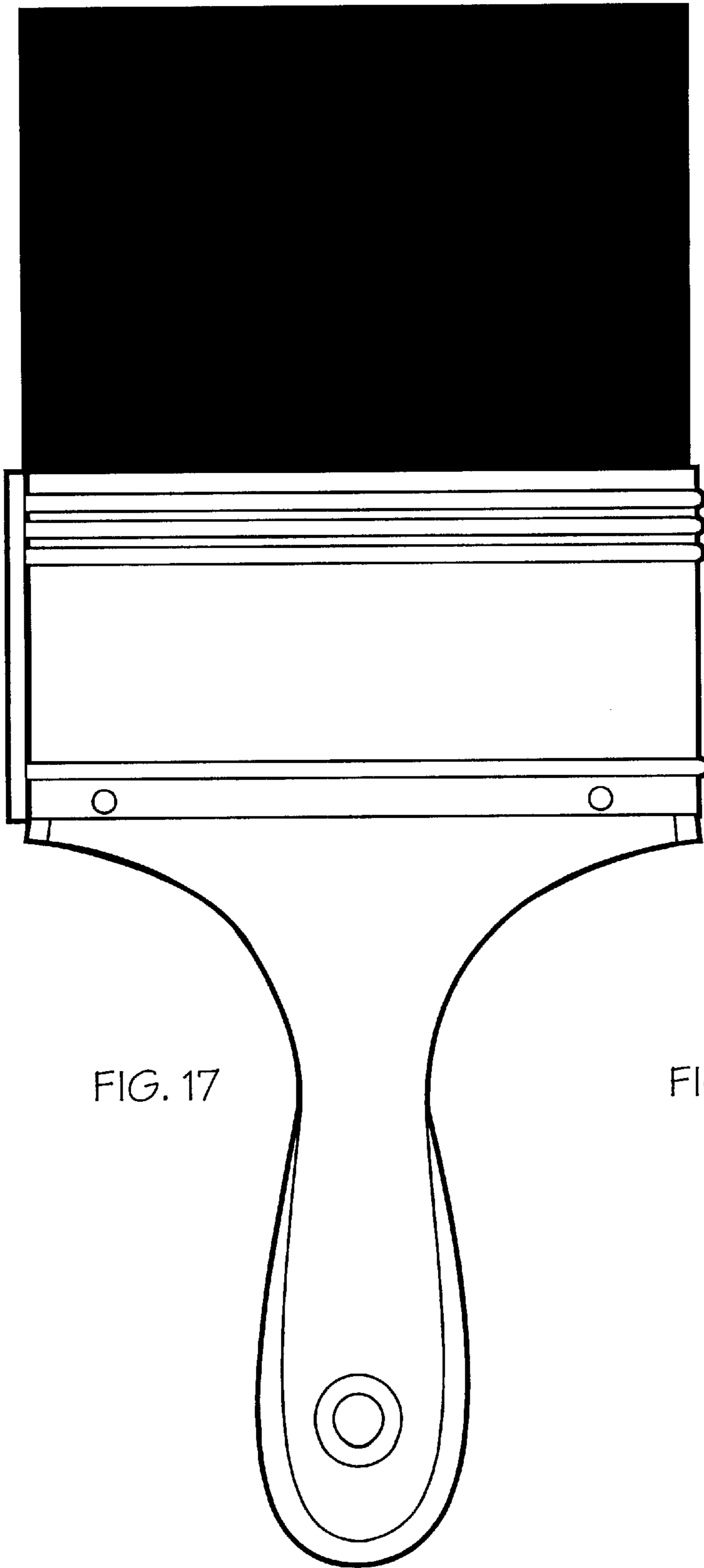

FIG. 19

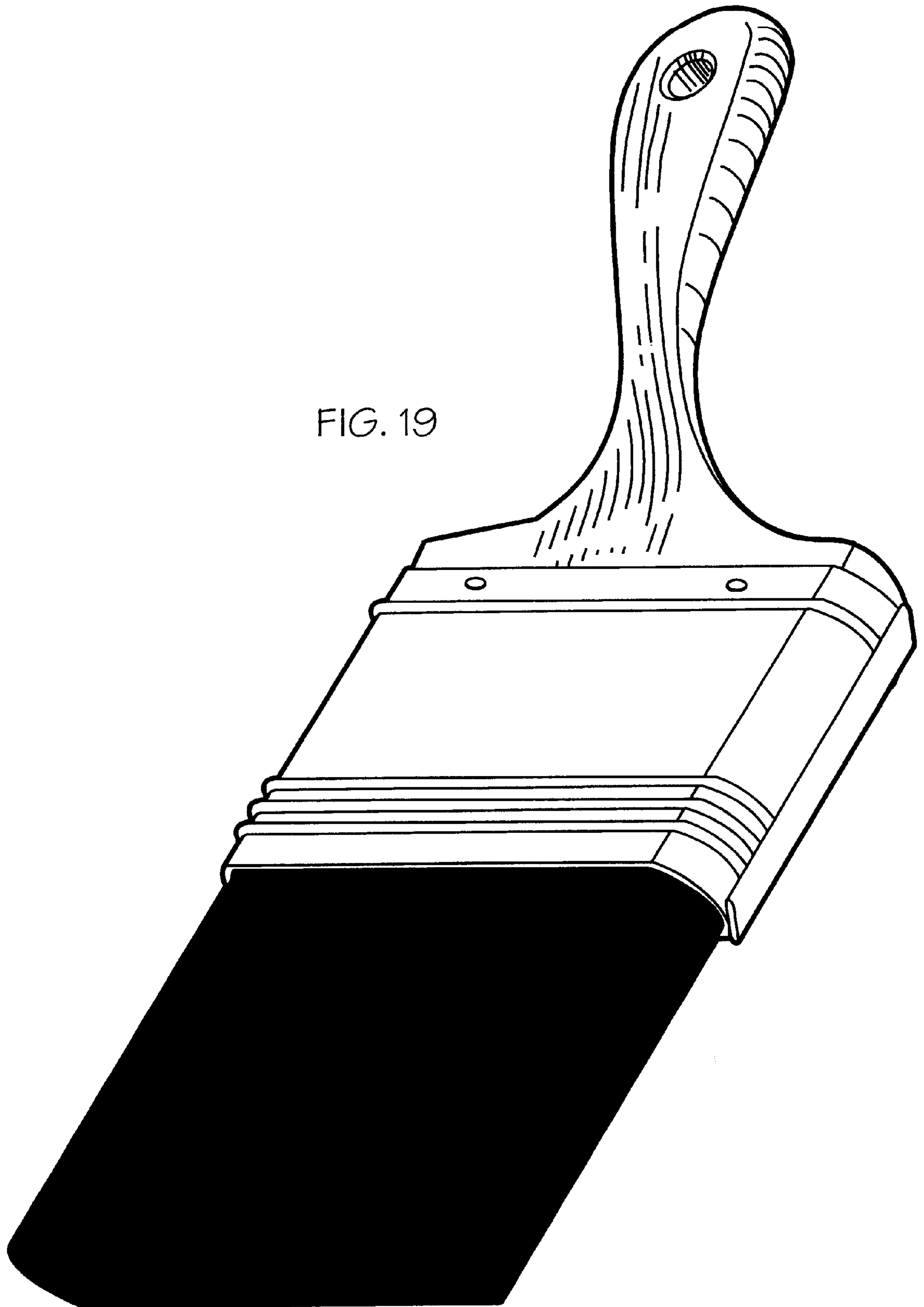

FIG. 20

