



US00D475338S

(12) **United States Design Patent**
Zurn et al.

(10) **Patent No.:** **US D475,338 S**

(45) **Date of Patent:** **** Jun. 3, 2003**

(54) **MOTOR BOAT**

(76) Inventors: **Douglas A. Zurn**, 58 Bennett Rd.,
Marblehead, MA (US) 01945; **Robert**
L. Johnstone, III, 7 Church St.,
Charleston, SC (US) 29401

(**) Term: **14 Years**

(21) Appl. No.: **29/170,141**

(22) Filed: **Nov. 1, 2002**

(51) **LOC (7) Cl.** **12-06**

(52) **U.S. Cl.** **D12/300**

(58) **Field of Search** D12/300, 301,
D12/315; 114/144 E, 249, 259

(56) **References Cited**

U.S. PATENT DOCUMENTS

5,715,770 A * 2/1998 Heyworth 114/249
6,026,759 A * 2/2000 Hazelett et al. 114/144 E
D429,682 S * 8/2000 Garland et al. D12/315

OTHER PUBLICATIONS

M & E Marine, 1998, Boat located at top right of page, p.
231.*

* cited by examiner

Primary Examiner—Holly Baynham

(74) *Attorney, Agent, or Firm*—Roynance, Abrams, Berdo
& Goodman, L.L.P.

(57) **CLAIM**

The ornamental design for a motor boat, as shown and
described.

DESCRIPTION

FIG. 1 is a left rear perspective view of a first embodiment
of a motor boat showing our new design;

FIG. 2 is a right side elevational view of the motor boat
shown in FIG. 1;

FIG. 3 is a left side elevational view of the motor boat shown
in FIGS. 1 and 2;

FIG. 4 is a top view of the motor boat shown in FIGS. 1–3;

FIG. 5 is a bottom view of the motor boat shown in FIGS.
1–4;

FIG. 6 is a front elevational view of the motor boat shown
in FIGS. 1–5;

FIG. 7 is a rear elevational view of the motor boat shown in
FIGS. 1–6;

FIG. 8 is an environmental, left side elevational view with
the broken line showing of a flybridge structure with a
bimini top being for illustrative purposes only and forming
no part of the claimed design;

FIG. 9 is a left rear perspective view of a second embodi-
ment of a motor boat showing our new design, the third
embodiment having a modified side window configuration;

FIG. 10 is a left rear perspective view of a third embodi-
ment of a motor boat showing our new design, the fourth embodi-
ment being a stretched version of the embodiment shown in
FIG. 9;

FIG. 11 is a left rear perspective view of a fourth embodi-
ment of a motor boat showing our new design, the fifth
embodiment being a stretched version of the embodiment
shown in FIGS. 1–7; and,

FIG. 12 is a left side elevational view of the motor boat
shown in FIG. 11.

The dashed line renderings of the flybridge structure and
bimini top in FIG. 8 are for illustrative purposes only and
form no part of the claimed design.

1 Claim, 11 Drawing Sheets

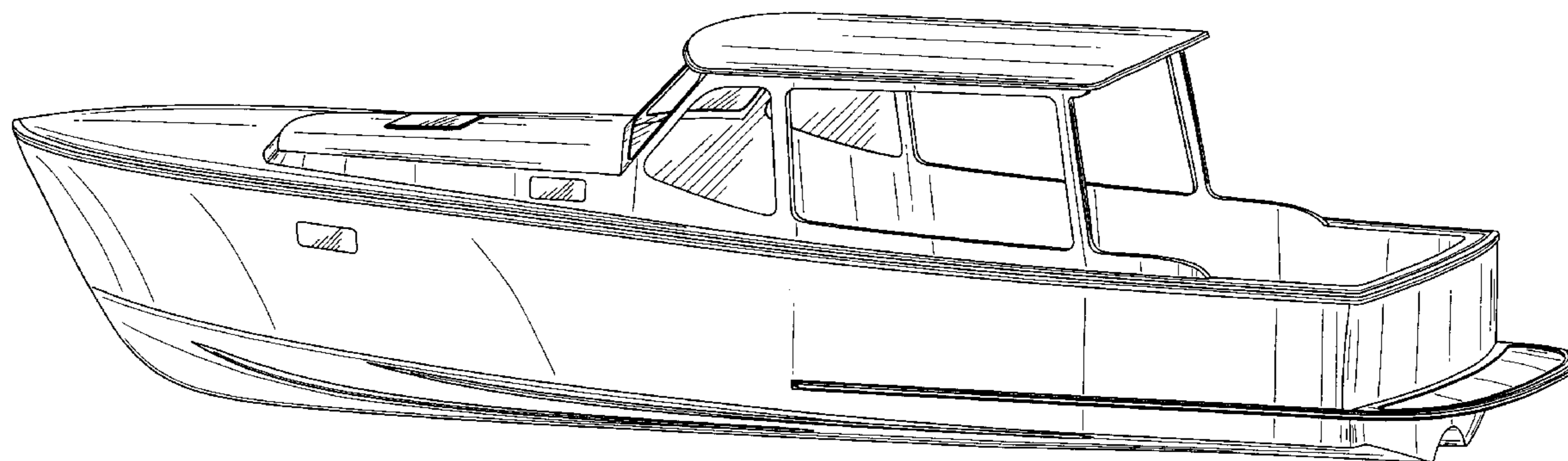

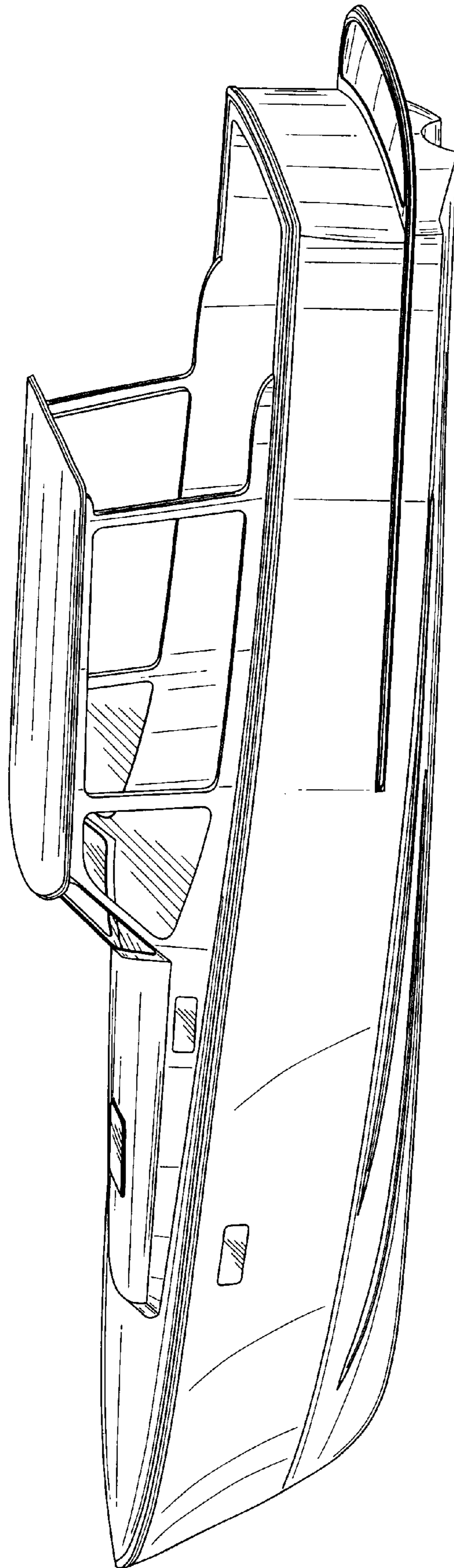

FIG. 1

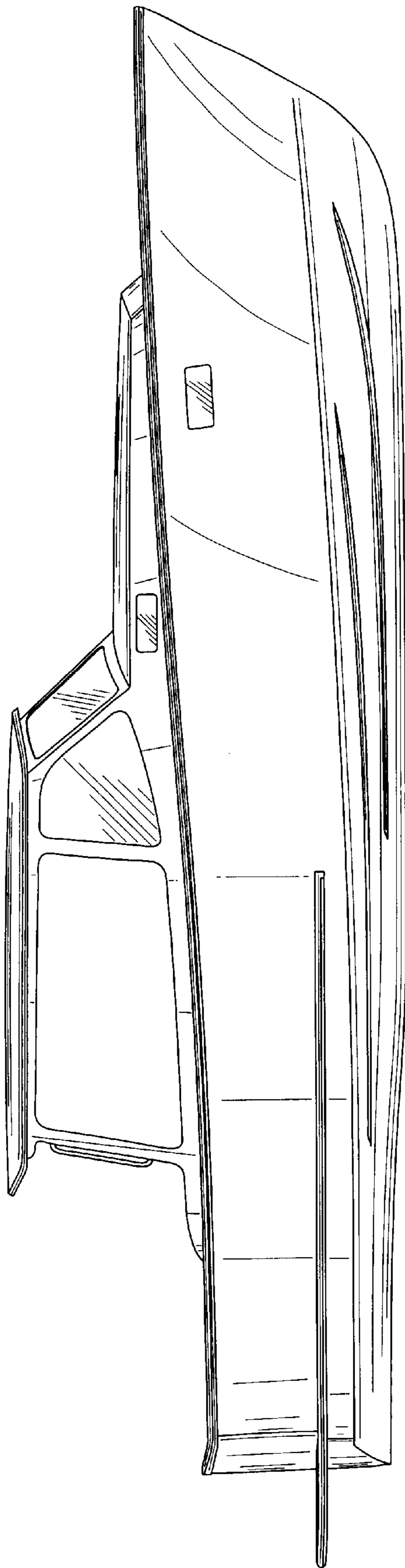

FIG. 2

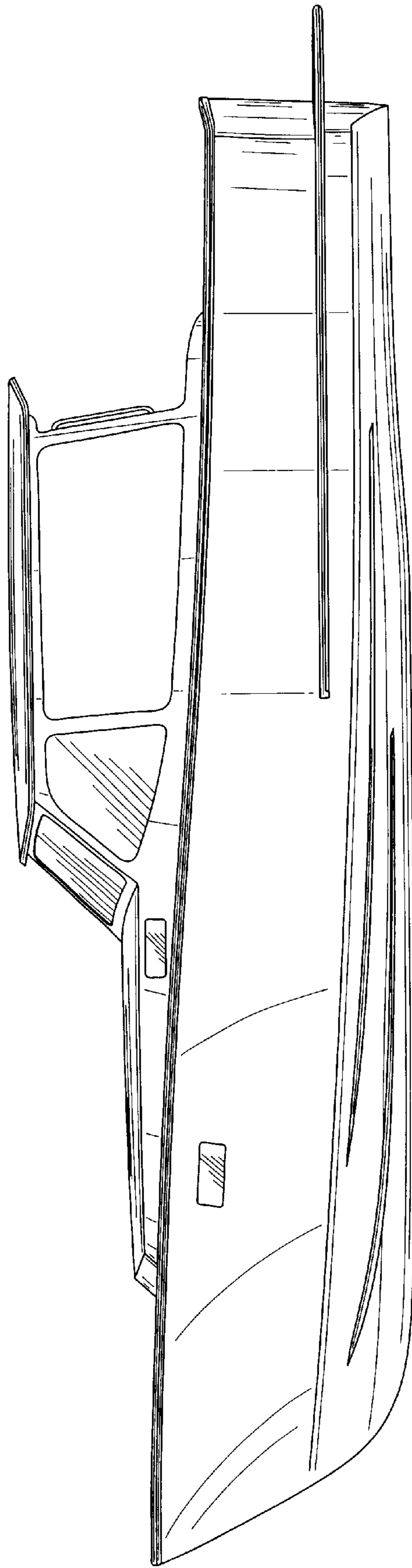

FIG. 3

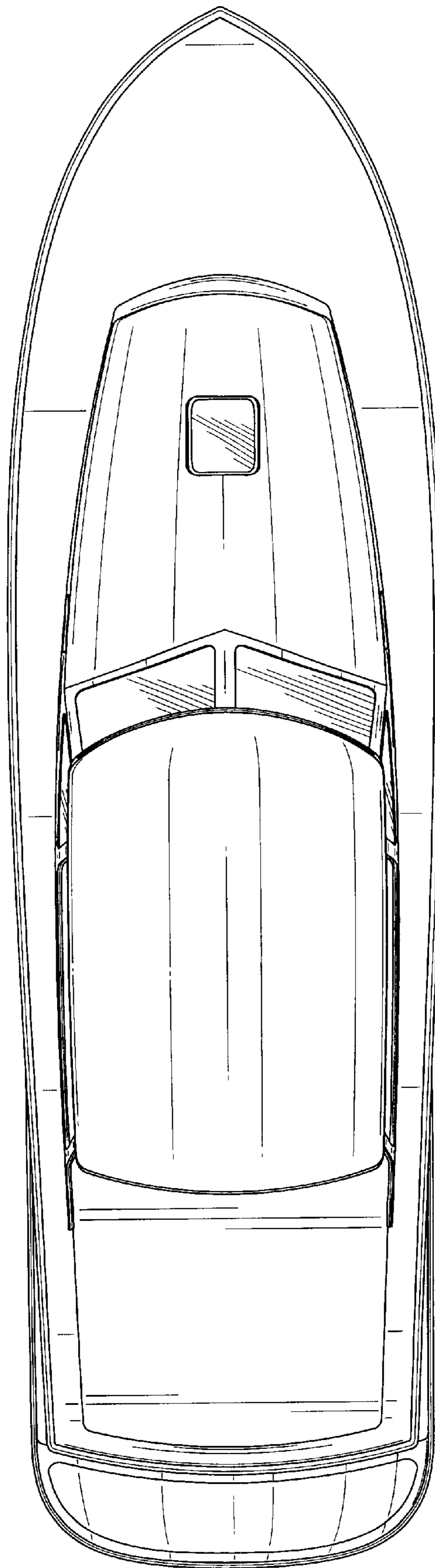

FIG. 4



FIG. 5

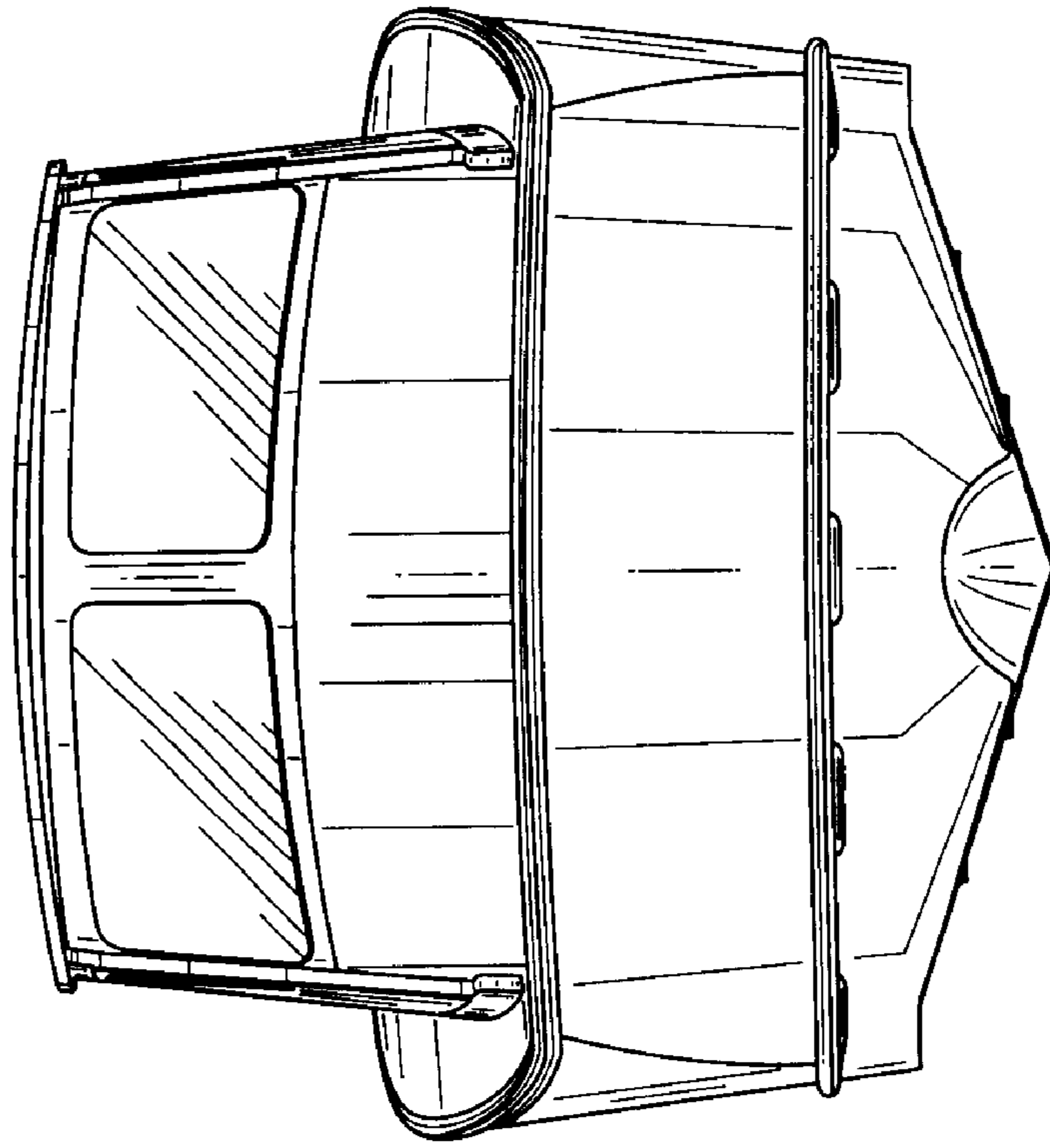

FIG. 7

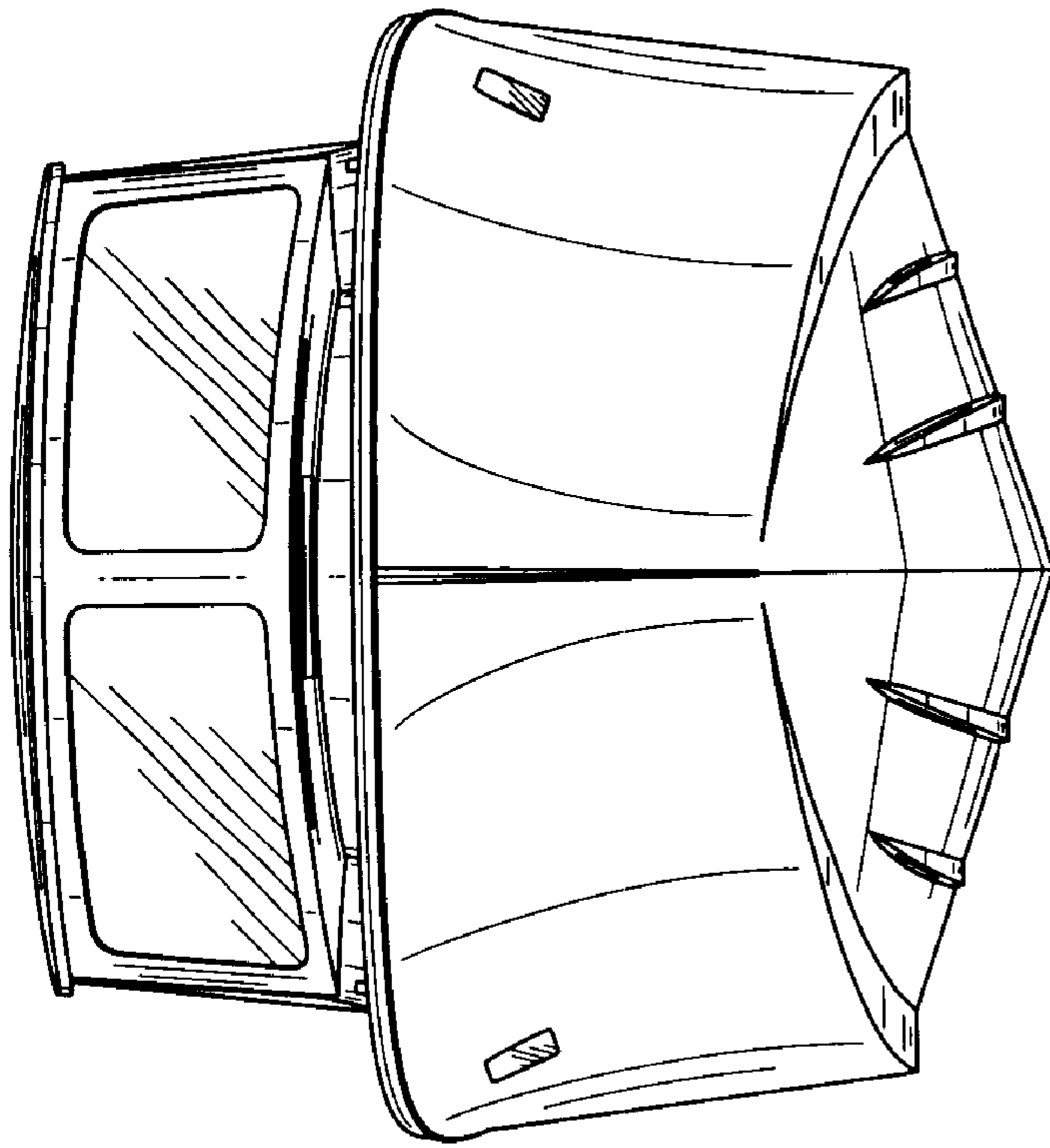

FIG. 6

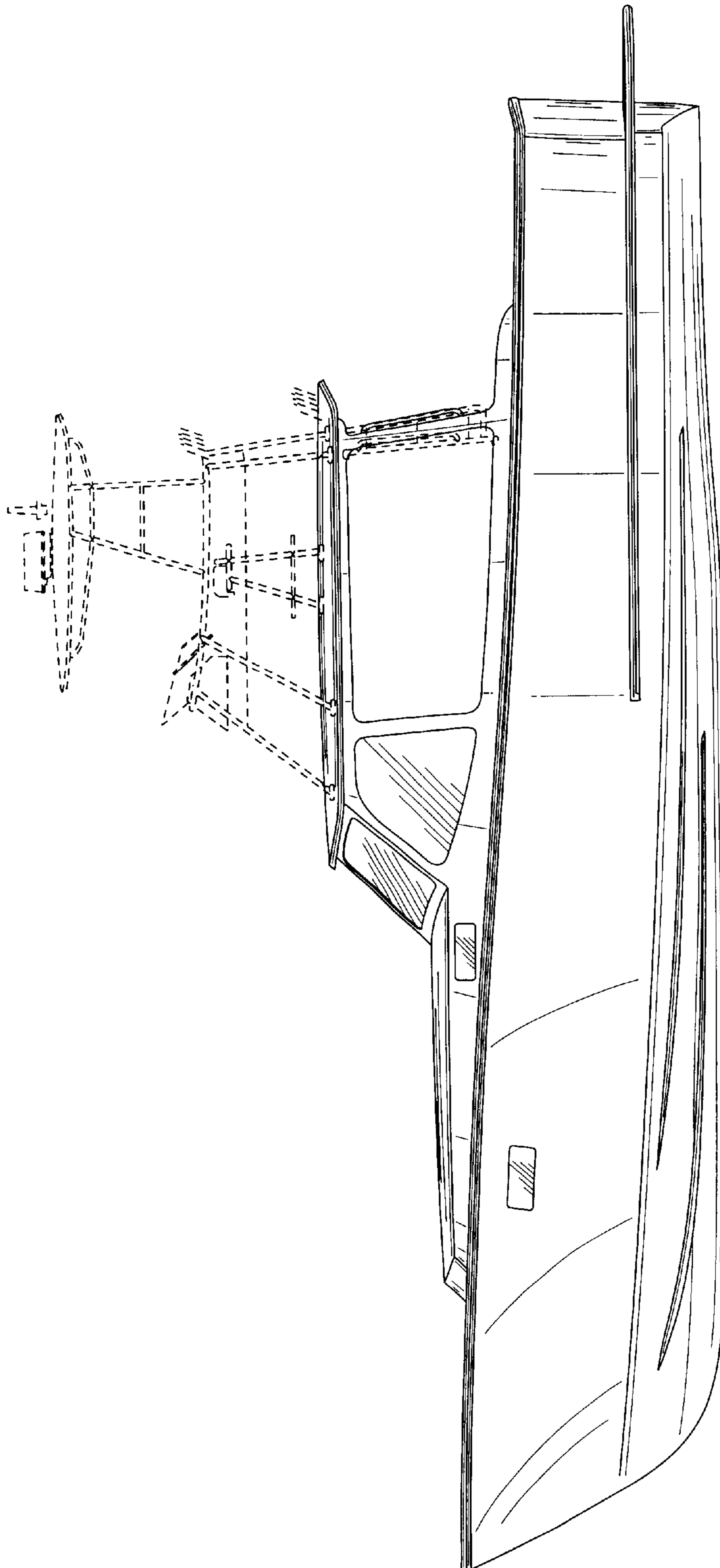

FIG. 8

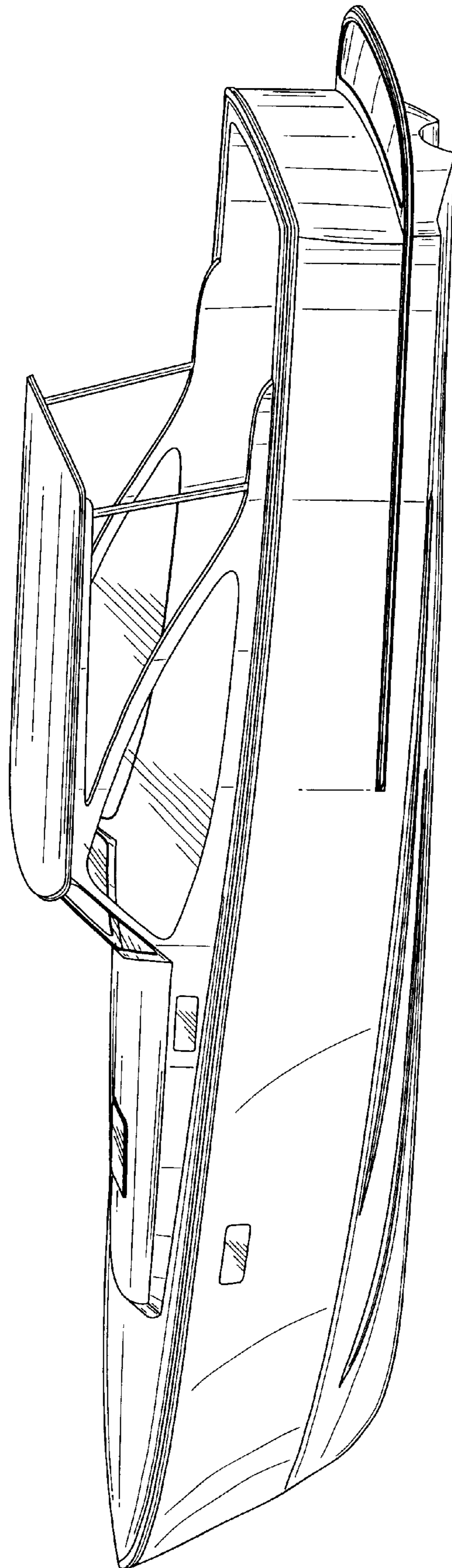

FIG. 9

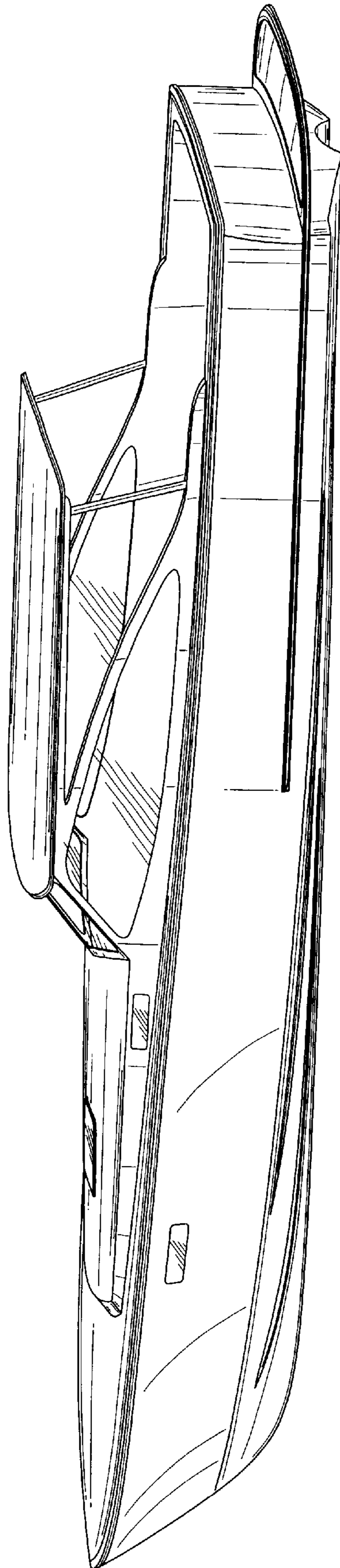

FIG. 10

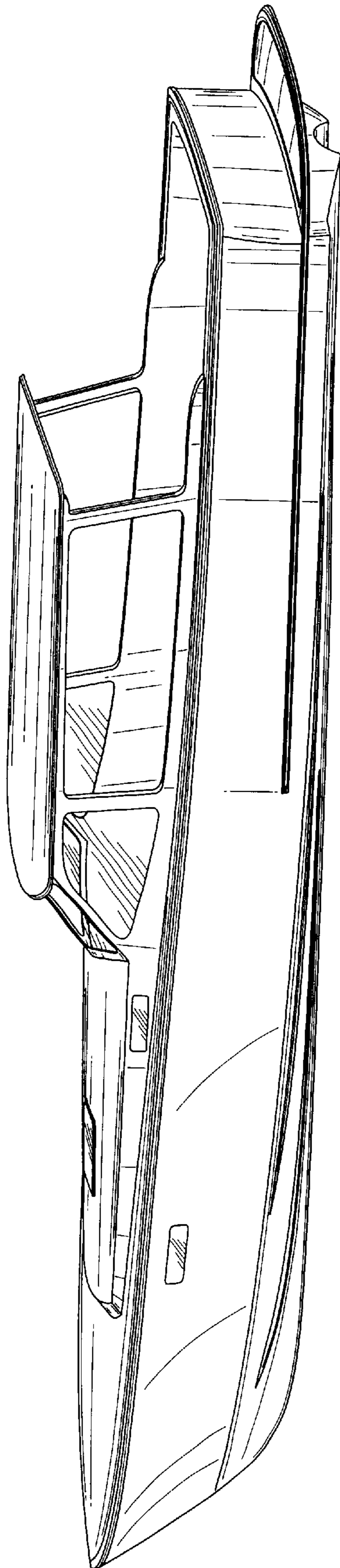

FIG. 11

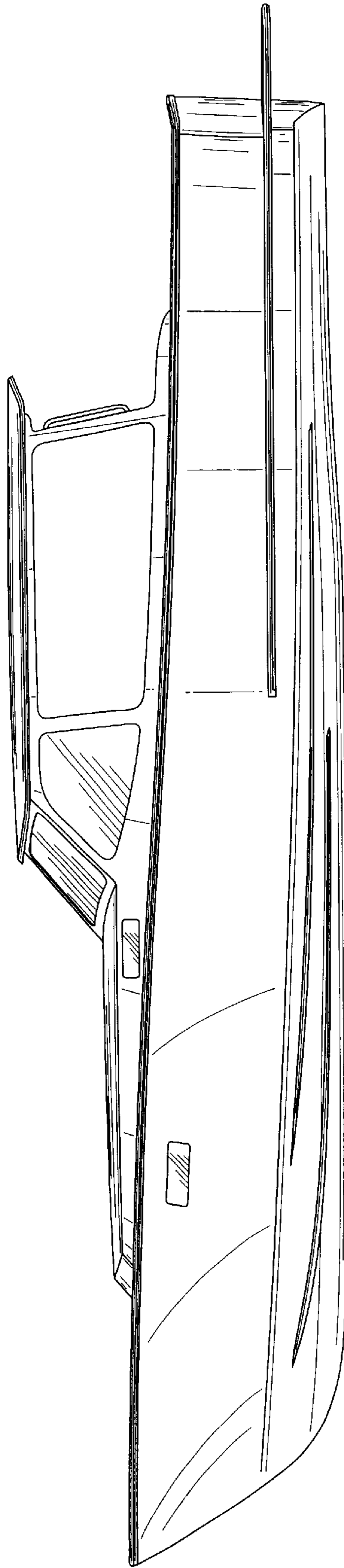

FIG. 12