



US00D475274S

(12) **United States Design Patent**
Ho

(10) **Patent No.:** **US D475,274 S**

(45) **Date of Patent:** **** Jun. 3, 2003**

(54) **LOCKS ASSEMBLY FOR STEERING WHEELS**

D370,616 S * 6/1996 Fard D8/331
D370,840 S * 6/1996 Tsai D8/339
5,557,956 A * 9/1996 Merz 70/209
D421,891 S * 3/2000 Yang D8/331

(76) **Inventor:** **Tien-Chin Ho**, 54, Keng-Tsy-Pin, Heh-Pin Village, Chu-Chi Hsiang, Chia Yi Hsien (TW)

* cited by examiner

(**) **Term:** **14 Years**

Primary Examiner—Brian N. Vinson
(74) *Attorney, Agent, or Firm*—Larson & Taylor PLC

(21) **Appl. No.:** **29/171,607**

(57) **CLAIM**

(22) **Filed:** **Nov. 26, 2002**

The ornamental design for locks assembly for steering wheels, as shown.

(30) **Foreign Application Priority Data**

Sep. 19, 2002 (TW) 91305356

DESCRIPTION

(51) **LOC (7) Cl.** **08-07**

FIG. 1 is a perspective view of the locks assembly for steering wheels showing my new design;
FIG. 2 is a right side elevational view thereof;
FIG. 3 is a top plan view thereof;
FIG. 4 is a front elevational view thereof;
FIG. 5 is a bottom plan view thereof;
FIG. 6 is a left side elevational view thereof; and,
FIG. 7 is a rear elevational view thereof.

(52) **U.S. Cl.** **D8/341**

(58) **Field of Search** D8/330, 331, 339, D8/341; 70/57, 58, 158, 237, 252, 207, 209, 211, 214

(56) **References Cited**

U.S. PATENT DOCUMENTS

5,239,849 A * 8/1993 Gallardo 70/209

1 Claim, 4 Drawing Sheets

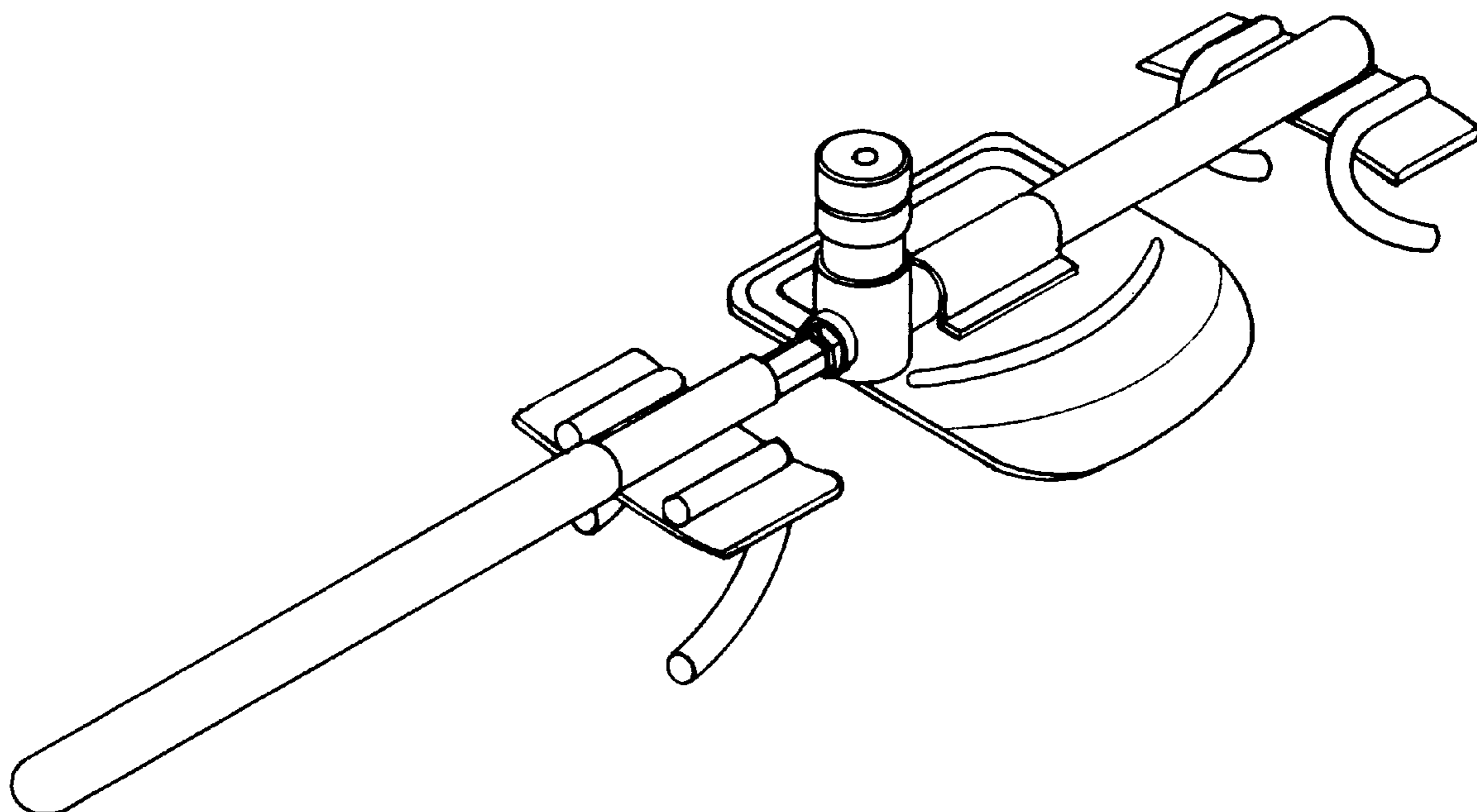

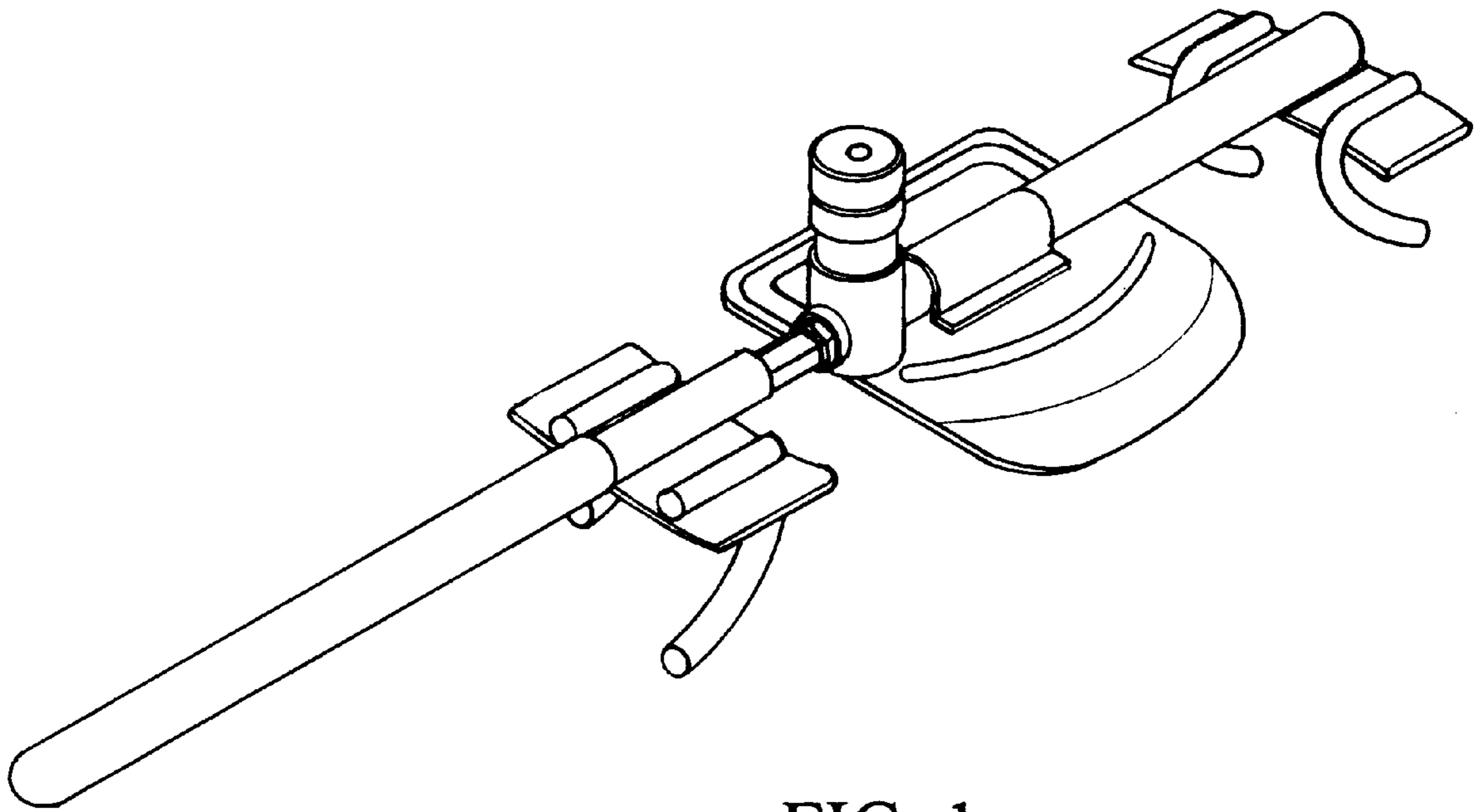

FIG. 1

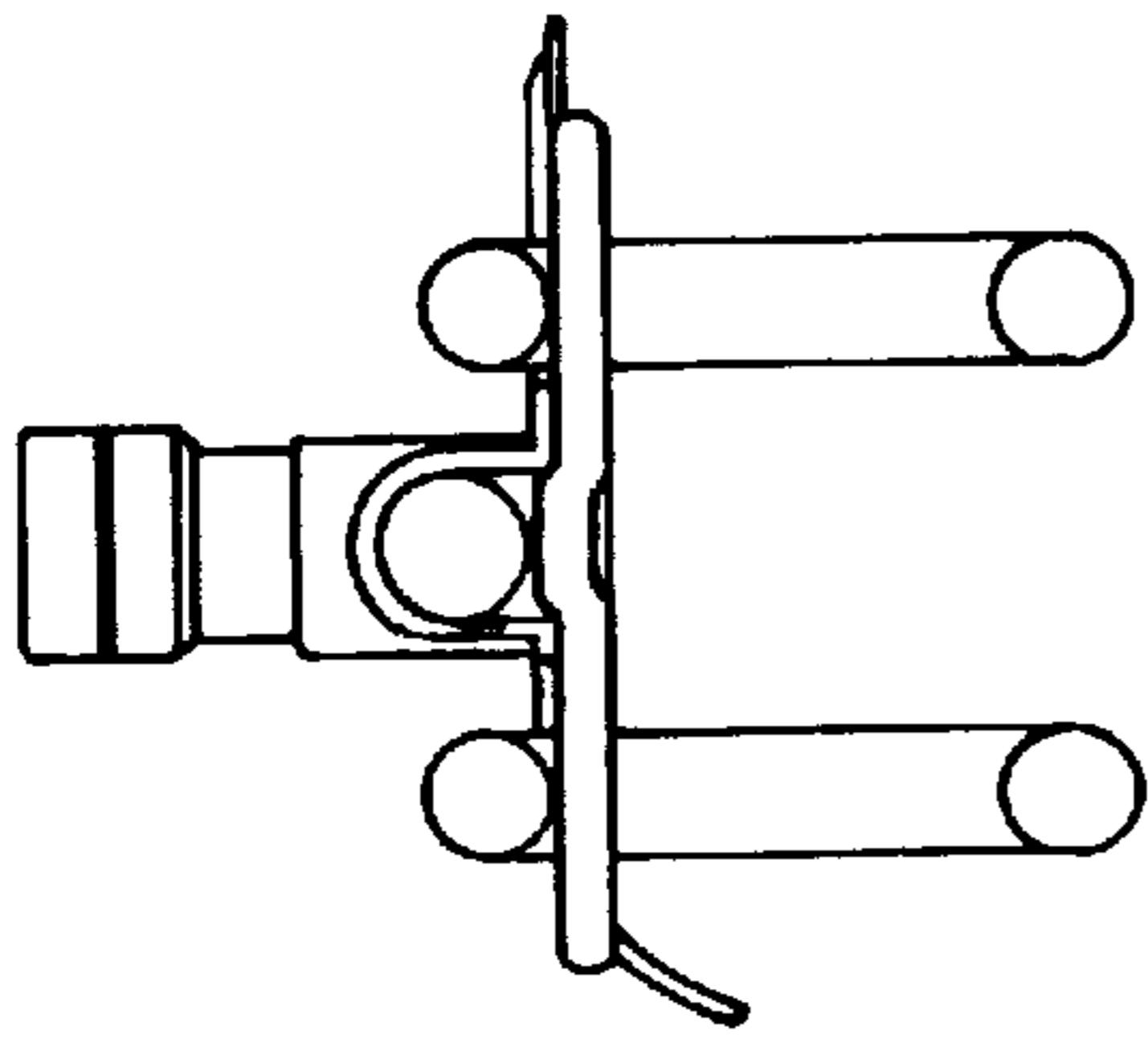

FIG. 2

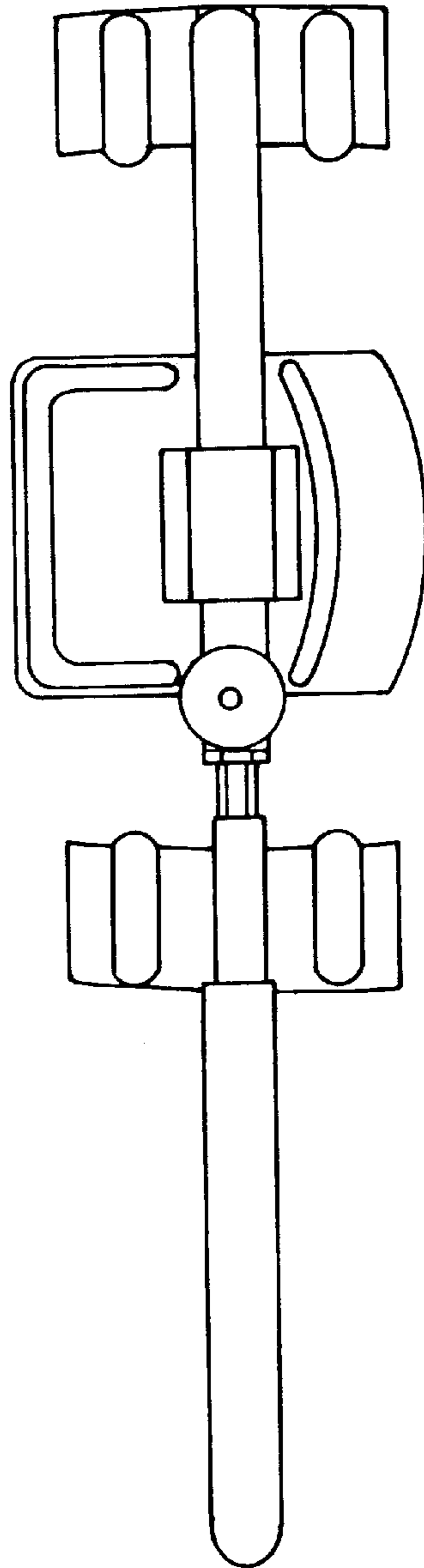

FIG. 3

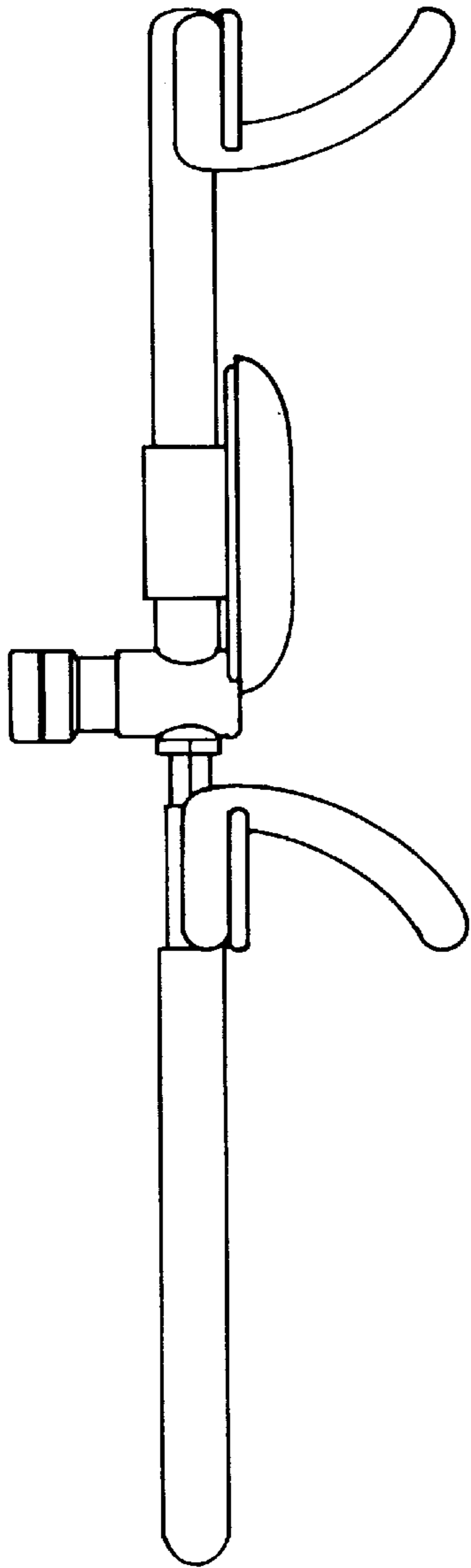

FIG. 4

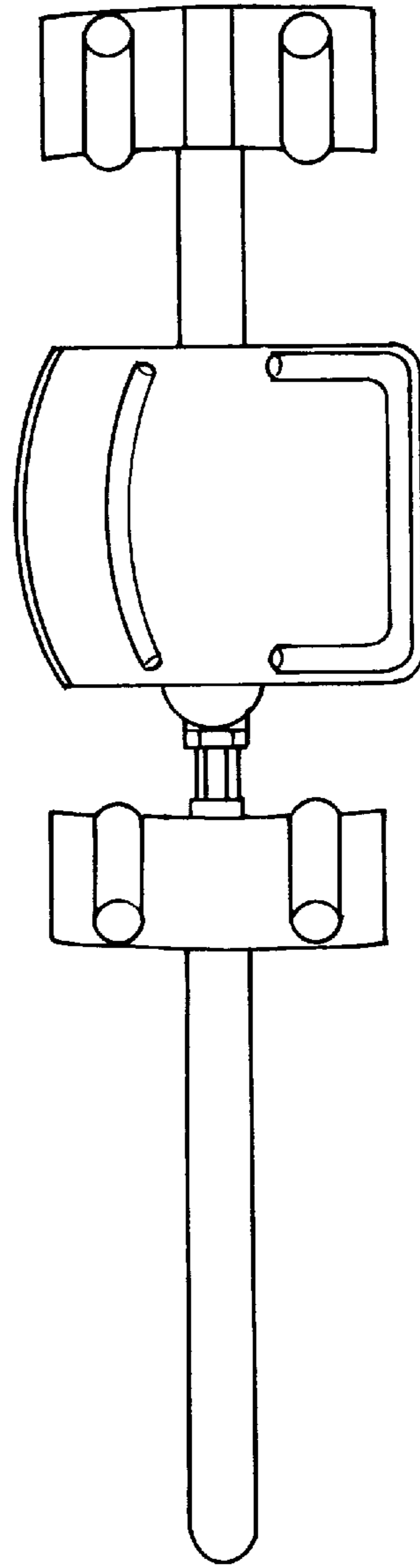

FIG. 5

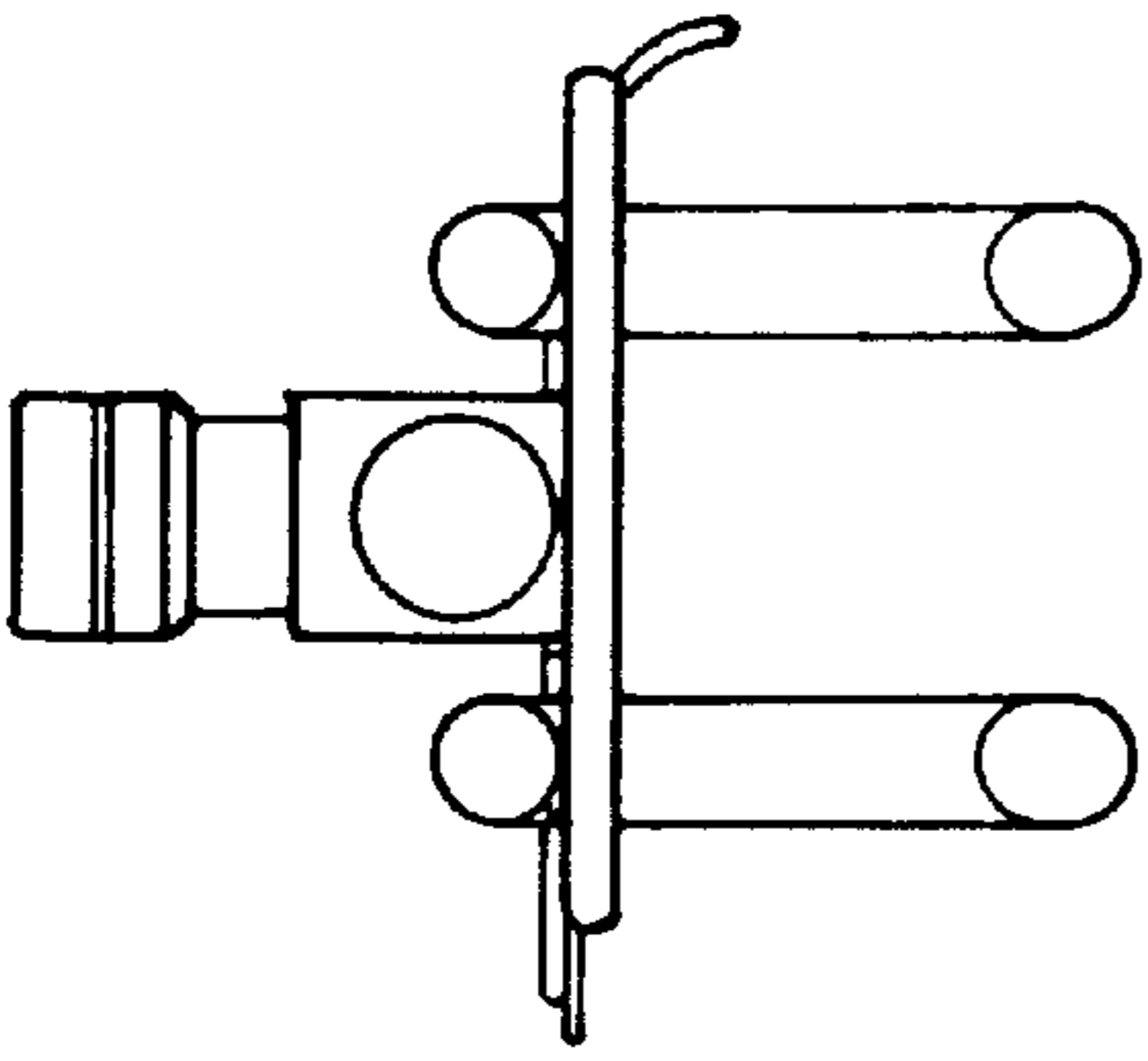

FIG. 6

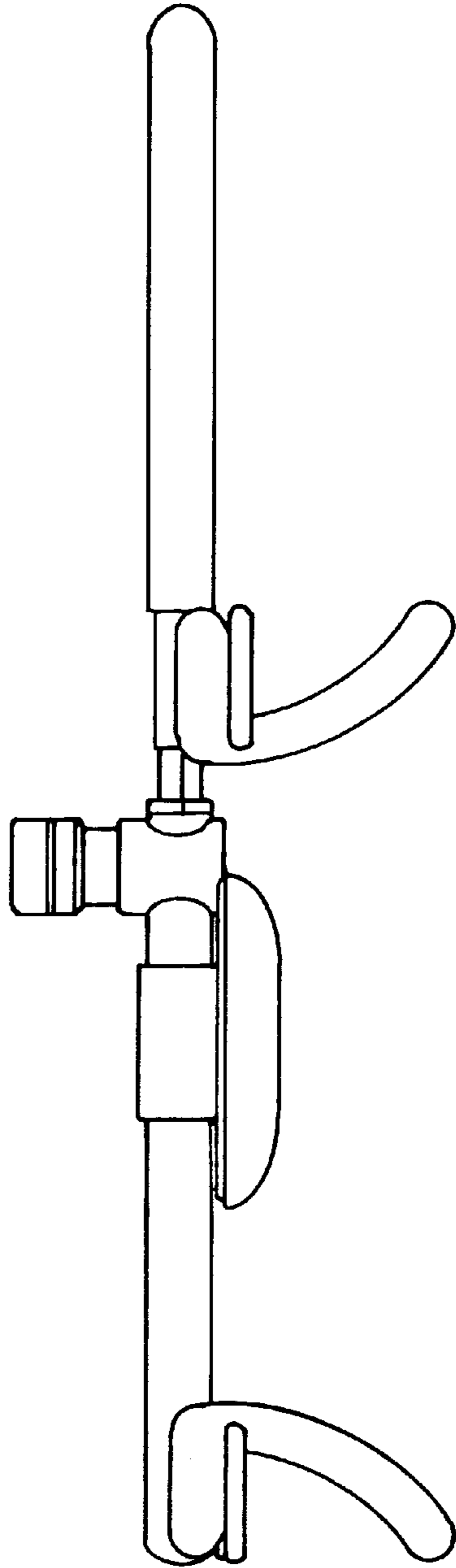

FIG. 7